

Intel[®] Core[™] 2 Duo Processor and Intel[®] GM45 Express Chipset (with DDR2 System Memory)

Development Kit User's Manual

July 2008



INFORMATION IN THIS DOCUMENT IS PROVIDED IN CONNECTION WITH INTEL® PRODUCTS. NO LICENSE, EXPRESS OR IMPLIED, BY ESTOPPEL OR OTHERWISE, TO ANY INTELLECTUAL PROPERTY RIGHTS IS GRANTED BY THIS DOCUMENT. EXCEPT AS PROVIDED IN INTEL'S TERMS AND CONDITIONS OF SALE FOR SUCH PRODUCTS, INTEL ASSUMES NO LIABILITY WHATSOEVER, AND INTEL DISCLAIMS ANY EXPRESS OR IMPLIED WARRANTY, RELATING TO SALE AND/OR USE OF INTEL PRODUCTS INCLUDING LIABILITY OR WARRANTIES RELATING TO FITNESS FOR A PARTICULAR PURPOSE, MERCHANTABILITY, OR INFRINGEMENT OF ANY PATENT, COPYRIGHT OR OTHER INTELLECTUAL PROPERTY RIGHT. Intel products are not intended for use in medical, life saving, life sustaining, critical control or safety systems, or in nuclear facility applications.

Intel may make changes to specifications and product descriptions at any time, without notice.

Intel Corporation may have patents or pending patent applications, trademarks, copyrights, or other intellectual property rights that relate to the presented subject matter. The furnishing of documents and other materials and information does not provide any license, express or implied, by estoppel or otherwise, to any such patents, trademarks, copyrights, or other intellectual property rights.

Designers must not rely on the absence or characteristics of any features or instructions marked "reserved" or "undefined." Intel reserves these for future definition and shall have no responsibility whatsoever for conflicts or incompatibilities arising from future changes to them.

Intel processor numbers are not a measure of performance. Processor numbers differentiate features within each processor family, not across different processor families. See http://www.intel.com/products/processor_number for details.

The Intel® Core™ 2 Duo processor and Intel® GM45 Express Chipset may contain design defects or errors known as errata which may cause the product to deviate from published specifications. Current characterized errata are available on request.

Contact your local Intel sales office or your distributor to obtain the latest specifications and before placing your product order.

Copies of documents which have an order number and are referenced in this document, or other Intel literature may be obtained by calling 1-800-548-4725 or by visiting Intel's website at <http://www.intel.com>.

BunnyPeople, Celeron, Celeron Inside, Centrino, Centrino logo, Core Inside, Dialogic, FlashFile, i960, InstantIP, Intel, Intel logo, Intel386, Intel486, Intel740, IntelDX2, IntelDX4, IntelSX2, Intel Core, Intel Inside, Intel Inside logo, Intel Leap ahead., Intel Leap ahead. logo, Intel NetBurst, Intel NetMerge, Intel NetStructure, Intel SingleDriver, Intel SpeedStep, Intel StrataFlash, Intel Viiv, Intel vPro, Intel XScale, IPLink, Itanium, Itanium Inside, MCS, MMX, Oplus, OverDrive, PDCharm, Pentium, Pentium Inside, skool, Sound Mark, The Journey Inside, VTune, Xeon, and Xeon Inside are trademarks or registered trademarks of Intel Corporation or its subsidiaries in the United States and other countries.

*Other names and brands may be claimed as the property of others.

Copyright © 2008, Intel Corporation. All Rights Reserved.



Contents

1	About This Manual	8
1.1	Content Overview	8
1.2	Text Conventions	9
1.3	Glossary of Terms and Acronyms	10
1.4	Development Kit Technical Support	14
1.4.1	Online Support	14
1.4.2	Additional Technical Support	14
1.5	Related Documents	14
1.5.1	Ordering Hard Copies of Documents	15
2	Getting Started	17
2.1	Overview	17
2.2	Development Kit Contents	17
2.3	Additional Required Hardware (Not Included in the Development Kit)	18
2.4	Additional Required Software (Not included in the Development Kit)	19
2.5	Workspace Preparation	19
2.6	System Setup and Power-Up	20
2.6.1	Using the AC to DC Power Supply (Mobile Power Mode)	21
2.7	Power Down	21
2.8	System BIOS	22
2.8.1	Configuring the BIOS	22
2.8.2	Programming BIOS Using a Bootable USB Device	22
3	Development Board Features	25
3.1	Block Diagram	25
3.2	Mechanical Form Factor	25
3.3	Development Board Key Features	26
3.4	Software Key Features	29
3.4.1	AMI BIOS	29
3.5	Thermal Management	30
3.6	System Features and Operation	30
3.6.1	Processor Support	30
3.6.2	Processor Voltage Regulators	30
3.6.3	Front-Side Bus (FSB)	30
3.6.4	Processor Power Management	30
3.6.5	Processor Active Cooling	31
3.6.6	Manual Processor Voltage ID (VID) Support	31
3.6.7	Chipset	31
3.6.8	System Memory	32
3.6.9	Video Display	32
3.6.10	PCI Express Slots	33
3.6.11	PCI Slots	33
3.6.12	On-Board LAN	33
3.6.13	Serial Peripheral Interface (SPI)	34
3.6.14	Soft Audio/Soft Modem	34



3.6.15	SATA Storage	34
3.6.16	USB Connectors	35
3.6.17	LPC Super I/O (SIO)/LPC Slot	36
3.6.18	Serial, IrDA	36
3.6.19	Intel® 82802 Firmware Hub Device Support	36
3.6.20	System Management Controller (SMC)/Keyboard Controller (KBC) ..	36
3.6.21	Clocks	37
3.6.22	Real Time Clock	37
3.6.23	Thermal Monitoring	37
3.6.24	Power Supply Solution	37
3.6.25	Manual VID support for Graphics VR.....	38
3.6.26	Debug Interfaces.....	38
3.6.27	Board Form-Factor	38
3.7	Power Management	39
3.7.1	Power Management States.....	39
3.8	Testability	39
3.9	Power Measurement Support.....	40
3.10	Power Supply Usage and Recommendation	44
4	Development Board Physical Reference	46
4.1	Board Components	46
4.2	Connectors	49
4.2.1	Back Panel Connectors	50
4.3	Configuration Settings.....	51
4.3.1	Configuration Jumpers/Switches	51
4.3.2	BSEL Jumper Settings	54
4.4	Power and Reset Push Buttons	55
4.5	Net Detect Button	55
4.6	LEDs	56
4.7	Other Headers	57
4.7.1	H8 Programming Headers.....	57
4.7.2	Sideband and Test Headers.....	58
Appendix A	Add-In Cards.....	59
A.1	Port 80-83 Add-in Card (Included)	59
A.2	PCI Expansion Card (Thimble Peak 2) (Included)	60
A.3	HDMI and Display Port Video Interface Add-In Card (Eaglemont) (Included) ..	60
A.3.1	Rework to change Eaglemont card from HDMI to Display Port	61
A.3.2	AUX Pull Down Rework.....	63
A.4	Intel® High Definition Audio Interposer Card (Mott Canyon 4) (Not Included)64	
A.4.1	Mott Canyon 4 Jumper Settings	65
A.5	ExpressCard Module Interposer (Duck Bay 3) (Not Included)	67
A.6	PCI Express mini card Interposer (Upham IV) (Not Included).....	68
A.7	Docking Connector Card (Saddlestring II) (Not Included)	69
Appendix B	Rework Instructions	72
B.1	Internal HDMI Enabling	72
B.2	Enabling the Integrated Trusted Platform Module (iTPM)	72
B.3	Enabling External HDMI.....	73
B.4	Support for Upham 4	73
B.5	Low Voltage High-Definition (HD) Audio Rework	73



Appendix C	Programming system BIOS using a flash programming device	75
Appendix D	CPU Thermal Solution (Heatsink) Installation	76

Figures

Figure 1.	Development Board Block Diagram.....	25
Figure 2.	Pillar Rock Development Board Components	47
Figure 3.	Back Panel Connectors	50
Figure 4.	D-Connector to Component Video Cable.....	50
Figure 5.	D-Connector to Composite Video Cable	51
Figure 6.	D-Connector to S-Video Cable	51
Figure 7.	Location of the Configuration Jumpers/Switches.....	52
Figure 8.	Power On and Reset Buttons	55
Figure 9.	Net Detect Button.....	56
Figure 10.	Port 80-83 Interposer Card.....	59
Figure 11.	PCI Expansion Card (Thimble Peak 2)	60
Figure 12.	Eaglemont Add-in Card	61
Figure 13.	Location of Resistors for Rework (before Rework)	62
Figure 14.	Location of Resistors for Rework (after Rework).....	62
Figure 15.	Location of Resistors for Rework.....	63
Figure 16.	AUX Pull-Down Rework	64
Figure 17.	Mott Canyon 4 Interposer Card	65
Figure 18.	Duck Bay 3 Interposer Card.....	67
Figure 19.	Upham IV Interposer Card.....	68
Figure 20.	Saddlestring II Docking Connector.....	70
Figure 21.	iHDMI Rework Instruction 1	72
Figure 22.	iHDMI Rework Instruction 2	72
Figure 23.	Low Voltage HD Audio Rework (Always Rail)	73
Figure 24.	Low Voltage HD Audio Rework (Sus Rail).....	74
Figure 25.	Step 2 - Heatsink and Backplate.....	76
Figure 26.	Step 4 - Backplate Pins	77
Figure 27.	Step 6 - Applying the Thermal Grease.....	78
Figure 28.	Step 7 - Squeezing Activation Arm	79
Figure 29.	Step 8 - Installing the Heatsink.....	80
Figure 30.	Step 9 - Plugging in the Fan	81
Figure 31.	Step 10 - Completed Assembly	82

Tables

Table 1.	Text Conventions	9
Table 2.	Definitions of Terms	10
Table 3.	Acronyms	11
Table 4.	Related Documents	15
Table 5.	Intel Literature Centers.....	15
Table 6.	Development Board Feature Set Summary	26
Table 7.	TV-Out Connections.....	32
Table 8.	PCI Express Ports.....	33



Table 9. Selection of I/O Voltage for the High Definition Audio.....	34
Table 10. SATA Ports.....	35
Table 11. USB Ports mapping.....	35
Table 12. System Power Management States.....	39
Table 13. System Power Management M-States.....	39
Table 14. Digital Multi-Meter Comparison.....	40
Table 15. System Voltage Rails.....	41
Table 16. Pillar Rock Development Board Components.....	47
Table 17. Configuration Jumper/Switches Settings.....	52
Table 18: BSEL Jumper Settings.....	54
Table 19. Power-On and Reset Push buttons.....	55
Table 20. LEDs.....	56
Table 21. H8 Programming Jumpers.....	58
Table 23. Port 80-83 Display Configurations.....	59
Table 22. Mott Canyon 4 Configuration Jumper/Switches Settings.....	65
Table 23. Upham IV default Jumper/Switches Settings.....	68
Table 24. Board Rework to Support Display Port on Saddlestring.....	70



Revision History

Document Number	Revision Number	Description	Revision Date
320276	001	Public launch release	July 2008

Note: The differences between the Pillar Rock (DDR2) and Silver Cascade (DDR3) User Guides are in the DDR2 vs. DDR3 memory controller interface, the *Configuration Jumpers and Switches Settings* Table and the *Development Board Components* Table. All other components and references are the same.

§



1 About This Manual

This user's manual describes the use of the Intel® Core™ 2 Duo Processor and Intel® GM45 Express Chipset development kit with DDR2 SDRAM system memory. This manual has been written for OEMs, system evaluators, and embedded system developers. This document defines all jumpers, headers, LED functions, and their locations on the development board, along with features of the board's subsystems. This manual assumes basic familiarity with installing and configuring hardware and software in a personal computer system.

There are two development board options available as a part of this kit. The first option uses DDR2 SDRAM memory. The DDR2 development board is referred to as *Pillar Rock*. The second option uses DDR3 SDRAM memory. The DDR3 development board is referred to as *Silver Cascade*. All other components and subsystems on the boards are the same unless explicitly noted. This manual will cover the features and details of the *Pillar Rock* development board.

For the latest information about the Intel® Core™ 2 Duo processor and Intel® GM45 Express Chipset Development Kit, visit:

<http://developer.intel.com/design/intarch/devkits/index.htm>

For design documents related to the Intel® Core™ 2 Duo processor and Intel® GM45 Express Chipset please visit:

Processor: http://developer.intel.com/design/intarch/core2duo/tech_docs.htm

Chipset: <http://www.intel.com/products/embedded/chipsets.htm>

1.1 Content Overview

Chapter 1.0, "About This Manual" — This chapter contains a description of conventions used in this manual. The last few sections explain how to obtain literature and contact customer support.

Chapter 2.0, "Getting Started"— Describes the contents of the development kit. This chapter explains the basics steps necessary to get the board running. This chapter also includes information on how to update the BIOS.

Chapter 3.0, "Development Board Features" — This chapter provides details on the hardware features of the development board. It explains the Power Management and Testability features.

Chapter 4.0, "Development Board Physical Reference"— This chapter provides a list of major board components and connectors. It gives a description of jumper settings and functions. The chapter also explains the use of the programming headers.

Appendix A, "Add-In Cards" – This chapter contains information on add-in cards available from Intel that can be used with the development board.



Appendix B, "Rework Instructions" – This chapter contains rework instructions for the development board and for some of the add-in cards to enable additional supported features and functionality.

Appendix C, "Programming system BIOS using a flash programming device provides step by step instructions on programming the flash using a flash programming device

Appendix D, "CPU Thermal Solution (Heatsink) Installation Instructions" gives detailed installation instructions for the Intel® Core™ 2 Duo processor heatsink.

1.2 Text Conventions

The notations listed in [Table 1](#) may be used throughout this manual.

Table 1. Text Conventions

Notation	Definition
#	The pound symbol (#) appended to a signal name indicates that the signal is active low. (e.g., PRSNT1#)
Variables	Variables are shown in italics. Variables must be replaced with correct values.
Instructions	Instruction mnemonics are shown in uppercase. When you are programming, instructions are not case-sensitive. You may use either uppercase or lowercase.
Numbers	Hexadecimal numbers are represented by a string of hexadecimal digits followed by the character H. A zero prefix is added to numbers that begin with A through F. (For example, FF is shown as 0FFH.) Decimal and binary numbers are represented by their customary notations. (That is, 255 is a decimal number and 1111 is a binary number. In some cases, the letter B is added for clarity.)
Units of Measure	<p>The following abbreviations are used to represent units of measure:</p> <ul style="list-style-type: none"> A amps, amperes GByte gigabytes KByte kilobytes KΩ kilo-ohms mA milliamps, milliamperes MByte megabytes MHz megahertz ms milliseconds mW milliwatts ns nanoseconds pF picofarads W watts V volts μA microamps, microamperes μF microfarads μs microseconds μW microwatts
Signal Names	Signal names are shown in uppercase. When several signals share a common name, an individual signal is represented by the signal name followed by a number, while the group is represented by the signal name followed by a variable (n). For example, the lower chip-select signals are



Notation	Definition
	named CS0#, CS1#, CS2#, and so on; they are collectively called CSn#. A pound symbol (#) appended to a signal name identifies an active-low signal. Port pins are represented by the port abbreviation, a period, and the pin number (e.g., P1.0).

1.3 Glossary of Terms and Acronyms

[Table 2](#) defines terms used in this document.

Table 2. Definitions of Terms

Term/Acronym	Definition
Assisted Gunning Transceiver Logic+	The front-side bus uses a bus technology called AGTL+, or Assisted Gunning Transceiver Logic. AGTL+ buffers are open-drain, and require pull-up resistors to provide the high logic level and termination. AGTL+ output buffers differ from GTL+ buffers with the addition of an active pMOS pull-up transistor to assist the pull-up resistors during the first clock of a low-to-high voltage transition.
Asynchronous GTL+	The processor does not utilize CMOS voltage levels on any signals that connect to the processor. As a result, legacy input signals such as A20M#, IGNNE#, INIT#, LINT0/INTR, LINT1/NMI, PWRGOOD, SMI#, SLP#, and STPCLK# utilize GTL+ input buffers. Legacy output signals (FERR# and IERR#) and non-AGTL+ signals (THERMTRIP# and PROCHOT#) also utilize GTL+ output buffers. All of these signals follow the same DC requirements as AGTL+ signals, however the outputs are not actively driven high (during a logical 0 to 1 transition) by the processor (the major difference between GTL+ and AGTL+). These signals do not have setup or hold time specifications in relation to BCLK[1:0], and are therefore referred to as "Asynchronous GTL+ Signals". However, all of the Asynchronous GTL+ signals are required to be asserted for at least two BCLKs in order for the processor to recognize them.
Infrared Data Assoc.	The Infrared Data Association (IrDA) has outlined a specification for serial communication between two devices via a bi-directional infrared data port. The development board has such a port and it is located on the rear of the board between the two USB connectors.
IMVP6+	The Intel Mobile Voltage Positioning specification for the Intel® Core™ 2 Duo Processor. It is a DC-DC converter module that supplies the required voltage and current to a single processor.
Media Expansion Card	The Media Expansion Card (MEC) provides digital display options through the SDVO interface. The MEC card also incorporates video-in via a x1 PCI Express* port.
Pad	The electrical contact point of a semiconductor die to the package substrate. A pad is only observable in simulations.
Pillar Rock	The name of the development board in this development kit that uses DDR2 SDRAM
Pin	The contact point of a component package to the traces on a substrate, such as the motherboard. Signal quality and timings may be measured at the pin.



Term/Acronym	Definition
Silver Cascade	The name of the development board in this development kit that uses DDR3 SDRAM
System Bus	The System Bus is the microprocessor bus of the processor.
System Management Bus	A two-wire interface through which various system components may communicate.
VCC (CPU core)	VCC (CPU core) is the core power for the processor. The system bus is terminated to VCC (CPU core).

[Table 3](#) defines the acronyms used throughout this document.

Table 3. Acronyms

Acronym	Definition
AC	Alternating Current
ACPI	Advanced Configuration and Power Interface
ADD2	Advanced Digital Display 2
ADD2N	Advanced Digital Display 2 Normal
AGTL or AGTL+	Assisted Gunning Transceiver Logic (See also Table 2 above)
AMI	American Megatrends Inc. (BIOS developer)
AMPS or iAMPS	(Intel) Adaptive Mobile Power System
AMT or iAMT	(Intel) Active Management Technology
ATA	Advanced Technology Attachment (disk drive interface)
ATX	Advance Technology Extended (motherboard form factor)
BGA	Ball Grid Array
BIOS	Basic Input/Output System
BSEL	Bus Select (Front Side Bus frequency control signals)
CL	Controller Link
CMOS	Complementary Metal-Oxide-Semiconductor
COM	Communications
CPU	Central Processing Unit (processor)
CRB	Customer Reference Board
DC	Direct Current
DC	Dual-Core
DDR	Double Data Rate
DDR2	Double Data Rate SDRAM version 2
DDR3	Double Data Rate SDRAM version 3



Acronym	Definition
DIMM	Dual Inline Memory Module
DMI	Direct Memory Interface
DOS	Disk Operating System
DP	Display Port
DPST or iDPST	(Intel) Display Power Savings Technology
EBL	Extended Battery Life
EC	Embedded Controller
ECC	Error Correcting Code
EHCI	Enhanced Host Controller Interface
EMA	Extended Media Access
eSATA	External SATA (Serial ATA)
ESD	Electrostatic Discharge
FCBGA	Flip Chip Ball Grid Array
FCPGA	Flip Chip Pin Grid Array
FS	Full-speed. Refers to USB
FSB	Front Side Bus
FWH	Firmware Hub
GbE	Gigabit Ethernet
GLCI	Gigabit LAN Connect Interface
GM45	Intel® GM45 Express Graphics and Memory Controller Hub
GMCH	Graphics and Memory Controller Hub
GND	Ground (VSS)
GPIO	General Purpose Input/Output
HDA	High Definition Audio
HDMI	High Definition Media Interface
HS	High-speed. Refers to USB
ICH	I/O Controller Hub
ICH9M	I/O Controller Hub 9M (Mobile)
IDE	Integrated Drive Electronics
IMVP-6+ or (Intel MVP-6+)	Intel Mobile Voltage Positioning – revision 6+
I/O	Input / Output
IrDA	Infrared Data Association
ITP	Integrated Test Port
KBC	Keyboard Controller



Acronym	Definition
L2	Level-2 (Cache)
LAN	Local Area Network
LED	Light Emitting Diode
LPC	Low Pin Count
LS	Low-speed. Refers to USB
LV	Low Voltage
LVDS	Low Voltage Differential Signaling (Video Standard)
mBGA	Mini Ball Grid Array
MEC	Media Expansion Card
MHz	Mega-Hertz
MT/s	Mega Transfers per second
NMI	Non-Maskable Interrupt
OEM	Original Equipment Manufacturer
PEG	PCI Express Graphics
PCI	Peripheral Connect Interface
PCIe	PCI Express*
PCM	Pulse Code Modulation
POST	Power On Self Test
PS/2	Personal System/2 (Keyboard and Mouse Connector)
PSI2	Power Status Indicator - 2
PWM	Pulse Width Modulation
RAID	Redundant Array of Inexpensive Disks
RCA	(Type of Audio and Video Connector)
RTC	Real Time Clock
SATA	Serial ATA
SDVO	Serial Digital Video Output
SIO	Super Input/Output
SKU (SKU Number)	Stock Keeping Unit (Stock Keeping Unit Number)
SMC	System Management Controller
SODIMM or SO-DIMM	Small Outline Dual In-line Memory Module
SOIC-8 or SOIC-16	Small Outline Integrated Circuit (8 or 16 pin package)
SPI	Serial Peripheral Interface
SPWG	Standard Panels Working Group - http://www.spwg.org/
SRC	Source (Clock)
SUT	System Under Test



Acronym	Definition
TME	Technical Marketing Engineer
TPM	Trusted Platform Module
TV or TVO	Television (Output)
μBGA	Micro Ball Grid Array
UHCI	Universal Host Controller Interface
ULV	Ultra-Low Voltage
USB	Universal Serial Bus
VGA	Video Graphics Adapter
VID	Voltage Identification
WiMAX	(Wireless Communications Standard)
WLAN	Wireless Local Area Network
VREG or VR	Voltage Regulator
WWAN	Wireless Wide Area Network
VCC	Power Signal
x1 (x2, etc)	By 1 (By 2, etc) (refers to number of PCIe Links)
XDP	eXtended Debug Port

1.4 Development Kit Technical Support

1.4.1 Online Support

Intel’s web site (<http://www.intel.com/>) provides up-to-date technical information and product support. This information is available 24 hours per day, 7 days per week, providing technical information whenever you need it.

1.4.2 Additional Technical Support

If you require additional technical support, please contact your Intel Representative or local distributor.

1.5 Related Documents

[Table 4](#) lists publicly available documents related to this development kit. For additional documentation, please contact your Intel Representative.



Table 4. Related Documents

Document Title	Location
Intel® Core™2 Duo Processor on 45-nm process Datasheet	http://www.intel.com/design/intarch/core2duo/tech_docs.htm
Mobile Intel® 4 Series Express Chipset Family Datasheet	http://www.intel.com/design/chipsets/embedded/gm45/techdocs.htm
Intel® I/O Controller Hub 9 (ICH9) Family Datasheet	http://www.intel.com/design/chipsets/embedded/gm45/techdocs.htm
Montevina Platform Design Guide - For Intel® Core™ 2 Duo Mobile Processor Built on 45-nm Process Technology, Mobile Intel® 45 Express Chipset and 82801IBM I/O Controller Hub (ICH9M)	Contact your Intel representative for access to this document. (Doc #355648)
Montevina Platform CRB Schematics – For Mobile Penryn Processor, Cantiga and ICH9M Chipset - Pillar Rock (DDR2) Customer Reference Board	Contact your Intel representative for access to this document. (Doc #355659)

1.5.1 Ordering Hard Copies of Documents

To order hard copies of product literature, do the following:

1. Determine the SKU Number

The SKU number is listed at the bottom of the download page for that document. It is also usually the first 6 digits of the name of the PDF file, such as: 12345612.pdf.

2. Call or E-mail a Request

Call: To place an order for a publication or text in hardcopy or CD form, please contact the Intel Literature Fulfillment Centers listed in [Table 5](#).

Table 5. Intel Literature Centers

Location	Telephone Number
U.S. and Canada	1-800-548-4725
International	1-303-675-2148
Fax	1-303-675-2120

Email: To order a publication or text in hardcopy or CD form, send your request to: intelsupport@hibbertgroup.com

Please make sure to include in your e-mailed request:

- SKU #
- Company Name
- Your Name (first, last)



Full mailing address
Daytime Phone Number in case of questions

Note: Please be aware not all documents are available in all media types. Some may only be available as a download.§

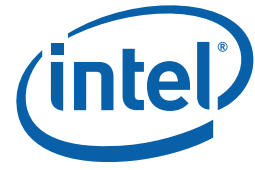

2 Getting Started

This chapter identifies the development kit's key components, features and specifications. It also details basic development board setup and operation.

2.1 Overview

The development board consists of a baseboard populated with the Intel® Core™ 2 Duo processor, the Intel® GM45 Express Chipset, other system board components and peripheral connectors.

2.2 Development Kit Contents

The following hardware, software and documentation is included in the development kit. Check for damage that may have occurred during shipment. Contact your sales representative if any items are missing or damaged.

- Letter to the Customer
- Development Kit User's Manual (this document)
- Software CD-ROM, which includes (see the readme.txt file for a complete list of CD-ROM contents):
 - Embedded system BIOS
 - BIOS installation utilities
 - Chipset drivers
 - Intel Embedded Graphics Drivers
 - Intel® Active Management Technology (AMT) software installation kit
- Pre-assembled development system, which includes:
 - Pillar Rock development board
 - Plexiglass stand with Acrylic pad
 - Mounting screws and standoffs (installed)
 - Intel® Core™ 2 Duo processor with 4 MB L2 Cache on 65nm process in the 478 pin Flip-Chip Pin Grid Array (Micro-FCPGA) package (Installed)
 - Processor thermal solution and CPU back plate



- Intel® GM45 Express Chipset Graphics and Memory Controller Hub (GMCH)
 - GMCH (GM45) heatsink
 - I/O Controller Hub 9M (ICH9M)
 - Type 2032, 3 V lithium coin cell battery
 - One 512 MByte, 200 Pin, DDR2 SO-DIMM
 - Port 80 display card
 - Power Supply
 - 80 GByte SATA Hard Disk Drive
 - DVD-ROM Drive
 - Disk Drive Power and SATA Cables
- One HDMI and Display Port add-in card (codename Eaglemont)
 - One PCI Extension Card (codename Thimble Peak 2)
 - One AC to DC Power Adapter

2.3 Additional Required Hardware (Not Included in the Development Kit)

The following additional hardware may be necessary to operate the development board.

VGA Monitor: Any standard VGA or multi-resolution monitor may be used. The setup instructions in this chapter assume the use of a standard VGA monitor or LCD monitor.

Keyboard: The development board supports both PS/2 and USB style keyboards.

Mouse: The development board supports both PS/2 and USB style pointing devices.

Hard Drives and Optical Disc Drives and cables: One SATA hard disk drive and one SATA optical DVD Drive are included in the development kit. Up to four SATA drives and two IDE devices (master and slave) may be connected to the development board. An optical disc drive (included) may be used to load the OS. All these storage devices may be attached to the board simultaneously.

Video Adapter Card: Integrated video is output from the VGA connector on the back panel of the development board. Alternately, a standard PCI Express* video adapter card, ADD2 card or MEC video adapter card may be used for additional display flexibility. Please contact the respective vendors for drivers and software for adapters not provided with this development kit. Check the BIOS and the graphics driver, where appropriate, for the proper video output settings.



Network Adapter and cables: A Gigabit network interface is provided on the development board. The network interface will not be operational until after all the necessary drivers are installed. A standard PCI/PCI Express* adapter may be used in conjunction with, or in place of, the onboard network adapter. Please contact the respective vendors for drivers and necessary software for adapters not provided with this development kit.

You must supply appropriate network cables to utilize the LAN connector or any other installed network cards.

Other Devices and Adapters: The development board functions much like a standard desktop computer motherboard. Most PC-compatible peripherals can be attached and configured to work with the development board.

2.4 Additional Required Software (Not included in the Development Kit)

The following additional software may be necessary to operate the development board.

Operating System: The user must supply any needed operating system installation files and licenses.

Application Software: The user must supply any needed application software.

2.5 Workspace Preparation

Caution: The development kit is shipped as an open system to provide flexibility in changing hardware configurations and peripherals in a lab environment. Since the board is not in a protective chassis, the user is required to take the following safety precautions in handling and operating the board.

1. The power supply cord is the main disconnect device to main power (AC power). The socket outlet should be installed near the equipment and should be readily accessible.
2. To avoid shock, ensure that the power cord is connected to a properly wired and grounded receptacle.
3. Ensure that any equipment to which this product will be attached is also connected to properly wired and grounded receptacles.
4. Use a flame retardant work surface
5. Ensure a static-free work environment before removing any components from their anti-static packaging. Wear an ESD wrist strap when handling the development board or other development kit components. The development board is susceptible to electrostatic discharge (ESD) damage, and such damage may cause product failure or unpredictable operation.



2.6 System Setup and Power-Up

Complete the following steps to operate the reference board.

These steps should already be completed in the kit. Check these items to ensure that nothing came loose during shipment.

- Place one or more DDR2 SO-DIMMs in the memory sockets, populating J5N1 and/or J5P1. The memory sockets are on the bottom side of the development board.
- Place the Intel® Core™ 2 Duo processor T9400 in socket U2E1 and lock in place (make sure to align the chip to the pin 1 marking)
- Attach the heatsink for the processor U2E1.
- Install the configuration jumpers as shown in Section 4.3.1 of this document. (Replacing detached 1-x jumpers is not required for proper board operation.)
- Attach hard drive data cable from development board SATA Connector J6J3 to the drive with the supplied SATA data cable.
- Attach hard drive power from the ATX power supply to the drive.
- Attach optical drive data cable from development board SATA Connector J6J2 to the drive with the supplied SATA data cable.
- Attach optical drive power from the ATX power supply to the drive.
- Connect the ATX power supply to the board at connector J4J1.

The following steps need to be completed by the user:

1. Attach the included CPU heatsink fan to the top of the CPU heatsink using the four screws provided. Plug the fan power in at the CPU Fan connector J2B3.
2. Connect a PS/2 keyboard at connector J1A1 (bottom) or connect a USB keyboard in one of the USB connectors.
3. Connect a PS/2 mouse at connector J1A1 (top) or connect a USB mouse in one of the USB connectors.
4. If using the chipset's integrated graphics, connect a monitor to the VGA Video output connector J2A2 with a VGA cable.
5. If using an external graphics card, plug a PCIe graphics card in the PCIe x1 slot J8B3 or a PCI Express Graphics card in the PCIE x16 slot J6B2. Connect a monitor to the card.
6. *For mobile power configuration*, unplug the ATX power supply from J4J1. Plug a mobile Intel® AMPS AC to DC power adapter into J1G9. Optionally plug in a battery pack into J1H1 or J1H2. *Do not mix mobile and desktop power configurations.*
7. Plug in the power cord of the ATX power supply or the Intel AMPS AC brick into a standard 120 V or 240 V AC power outlet.

Powering up the board:

1. Switch the power supply on (1) at the switch on the rear of the supply.



2. Press the power button located at SW1C1.
3. As the system boots, press F2 to enter the BIOS setup screen.
4. Check time, date, and configuration settings. The default settings should be sufficient for most users.
5. Insert an operating system installation disk into the optical drive.
6. Press F10 to save and exit the BIOS setup.
7. The system reboots begins to install the operating system from the optical drive.

Note: An operating system disk is not included in this kit and operating system installation will not be covered in this User Manual.

2.6.1 Using the AC to DC Power Supply (Mobile Power Mode)

There are a few limitations to development board operation when using the AC to DC power adapter (mobile power mode).

First, *do not mix mobile and desktop power configurations*. Unplug the ATX power supply from connector J4J1 before plugging in the AC to DC Power Adapter to connector J1G9.

Second, desktop peripherals, including add-in cards, will not work when the board is powered by the AC to DC power adapter or a battery (mobile power mode). If desktop peripherals are used, the development board must be powered using the included ATX power supply (desktop power mode).

Warning: Do not mix mobile and desktop power configurations. Unplug the ATX power supply from connector J4J1 before plugging in the AC to DC Power Adapter to connector J1G9, or a battery (not included) to connector J1H1-J1H2

Warning: The power supply cord is the main disconnect device from main AC power. The power outlet shall be installed near the equipment and shall be readily accessible.

2.7 Power Down

Powering down the board:

There are three options for powering-down the system

1. Power down from the operating system via the Windows Start Menu, or equivalent.
2. Press the power button on the motherboard at SW1C1 to begin power-down.
3. If the system is hung, it is possible to asynchronously shut the system down by holding down the power button (SW1C1) continuously for 4 seconds.

Note: We do not recommend powering down the board by shutting off power at the ATX power supply.



Note: If the power button on the ATX power supply is used to shut down the system, wait at least five seconds before turning the system on again to avoid damaging the system.

2.8 System BIOS

A version of the AMI* BIOS is pre-loaded on the development board.

Other BIOS vendors also support the Intel Core 2 Duo with Intel GM45 Express Chipset. For additional BIOS support, please contact your BIOS vendor.

2.8.1 Configuring the BIOS

The default BIOS settings may need to be modified to enable or disable various features of the development board. The BIOS settings are configured through a menu-driven user interface which is accessible during the Power On Self Test (POST). Press the F2 key or Delete key during POST to enter the BIOS interface. For AMI BIOS POST codes, visit:

<http://www.ami.com>

For BIOS Updates please contact your Intel Sales Representative.

2.8.2 Programming BIOS Using a Bootable USB Device

The flash chips which store the BIOS and BIOS extensions on the development board are connected to the SPI bus and are soldered down. One method of programming these devices is through software utilities as described below. The software files and utilities needed to program the BIOS are contained on the included CD-ROM. Another method is described in Appendix C - Programming system BIOS using a flash programming device.

Follow these steps to program the system BIOS using a bootable USB Device.

1. Prepare the workspace as outlined in Section 2.5 above.
2. Setup the system as outlined in Section 2.6 above.
6. **Warning:** Prior to flashing BIOS onto the platform AMT must be disabled in BIOS. Failure to do this will render the system inoperable.
 - a) Switch on the power supply (to "1").
 - b) Press the Power (PWR) Button on the development board
 - c) As the system starts to boot, enter the system BIOS setup by pressing (F2) or (Del)
 - d) Navigate to AMT and select (disable)
 - e) Navigate to "Save changes and exit".
 - f) Power off the system by pressing the power (PWR) button (SW1C1)
 - g) Turn off the power supply (remove power from the board) for at least 15 seconds



3. Copy the following files and utilities to the Bootable USB Device
 - BIOS Image Files
 - spifull.bin
 - BIOS Programming Software Utilities
 - fpt.exe (DOS SPI Flash Utility)
 - fparts.txt (helper file)
 - MAC Address Programming Software Utility
 - eeupdate.exe
 - Other helper files contained on the included CD-ROM
7. Unplug the hard disk drive (HDD) SATA cable from the board at connector J6J3 so that the board will boot from the bootable USB key.
8. Record the 12 digit MAC Address of the board from the sticker near the CPU
9. Insert the Bootable USB Key into one of the USB Ports on the Development Board
10. Switch on the power supply (to "1").
11. Press the Power (PWR) Button on the development board
12. Wait for the system to boot from the USB Key to a DOS prompt
13. From the DOS prompt (C:>), Run the following:
 - a. fpt -f spifull.bin
 - b. Make sure there are no warnings or errors
14. From DOS, Run the following to reprogram the MAC address:
 - c. eeupdate /nic=1 /mac=xxxxxxxxxxxx
(xxxxxxxxxxxx is the MAC Address from the sticker)
 - d. Make sure there are no warnings or errors
15. From DOS, Run the following to update the Keyboard and System Controller flash:
 - e. kscupdate ksc.bin
 - f. Make sure there are no warnings or errors
16. Power the system down by pressing the PWR button
17. Clear the CMOS by performing the following:
 - g. Shunt the CMOS CLR jumper (J5H2 – near the on-board battery)
 - h. Press the PWR button on the board. The board will not power on, but a couple of LEDs will flash.
 - i. Switch the power supply off to power down the board
 - j. Remove the CMOS CLR jumper (J5H2).
18. Unplug the bootable USB Key
19. Verify Correct BIOS Installation
 - k. Switch the power supply back on
 - l. Press the PWR button on the board to power-up the system
 - m. Boot to BIOS Configuration screen by pressing F2 at the BIOS splash screen.
 - n. In the BIOS Main screen, check that the "Project Version" lists the correct version of the BIOS.
 - o. Press the PWR key on the board to power the system back down.
20. Re-connect the SATA data cable from the hard drive to the development board at connector J6J3.

The system is now ready for normal operation.



§



3 Development Board Features

3.1 Block Diagram

Figure 1. Development Board Block Diagram

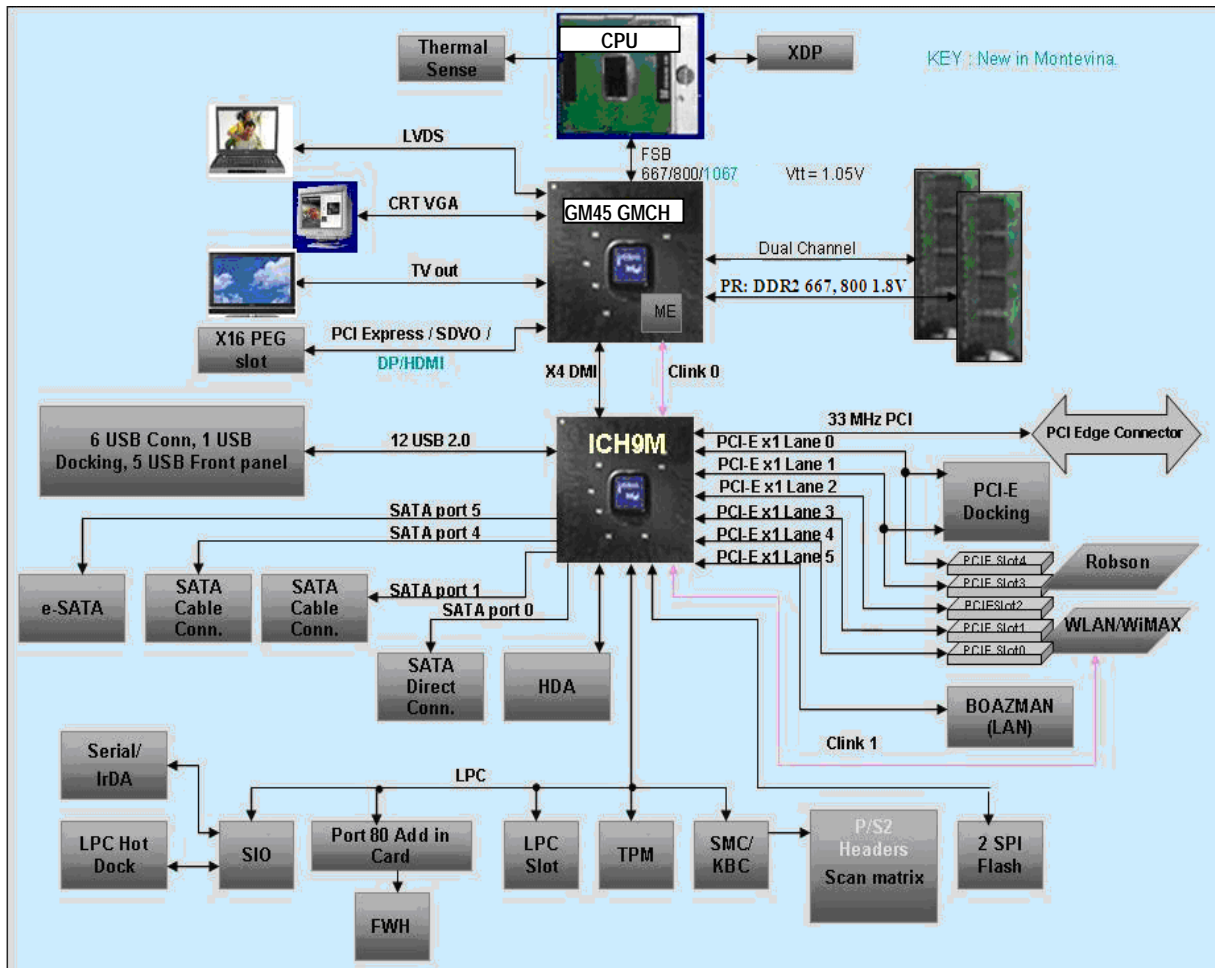

3.2 Mechanical Form Factor

The development board conforms to the ATX form factor. The development board will fit in most standard ATX chassis. A list of add-in card connector and slot locations is provided in Section 4.1. Internal and rear panel system I/O connectors are described in Section 0.



3.3 Development Board Key Features

Features of the development board are summarized in the following table.

Table 6. Development Board Feature Set Summary

	Description	Comments
Processor	Intel® Core™ 2 Duo processor T9400	479-pin Micro-FCPGA socket (Socket P) with 478-pin Micro-FCPGA package. 6MB L2 cache. FSB 667/800/1067 MT/s support
Chipset	Intel® GM45 Express Graphics and Memory Controller Hub (GM45 GMCH)	1299-pin Micro-FCBGA Package
	ICH9M	Intel® ICH9M I/O Controller Hub
Memory	Two DDR2 SO-DIMM slots.	<ul style="list-style-type: none"> • Maximum 4GB using 2 Gb technology and stacked SO-DIMMs. • Maximum 4GB using 2 Gb technology and non-stacked SO-DIMMs. • Minimum capacity 256 MB using 512-Mb technology • Supports DDR2 Frequency of 667 and 800 MHz
Video	One PCI Express (PCIe) Graphics Slot One dual channel LVDS Connector One VGA Connector One TV D-Connector supporting S-Video, Composite video and Component video Spread spectrum clocking	Intel GM45 Express Chipset supports four monitors, but only has 2 video pipes which support two screens each. Support for SPWG3.5. 24 bit color panel support (based on planned SPWG 4.0) Support for two SDVO channels via x16 PCIe connector (through add-in cards) Support for UDI and native HDMI (via a x16 PCIe connector, usage through Eaglemont and native HDMI through ADD card)
PCI	PCI revision 2.3 compliant (33MHz)	
	Three 5V PCI slots are supported through PCI Extension card	No PCI slots on motherboard Only one PCI gold finger on board
PCI Express*	Six x1 PCIe lanes Five x1 connectors One x16 connector	Revision 1.0a compliant Two sets of 2 in-line x1 PCIe slots Intel® 82567 GbE controller LAN on motherboard (muxed with one PCIe lane) x2 PCIe lanes to docking via resistor



	Description	Comments
		stuffing option
On-Board LAN	The Intel 82567 Gigabit Ethernet LAN	The Intel 82567 is connected to ICH9M via LCI interface and GLCI interface
Wireless Communication	Wireless LAN and Bluetooth support via Upham 4 interposer	WLAN/WiMAX combo card Echo Peak support via Upham 4
BIOS (SPI)	Supports two compatible flash device	Support for multi-vendor SPI Support multi package (SOIC-8 & SOIC-16) device
BIOS (Intel® 82802 Firmware Hub Device)	Support for 8-Mb Intel® 82802 Firmware Hub Device using Port 80 card	No Intel® 82802 Firmware Hub Device connector on motherboard Support only through port 80 add-in card (through the TPM header)
Soft Audio/Soft Modem	Intel® High Definition Audio (Intel® HD Audio) MDC Header	Support visa interposer Use Mott Canyon 4 daughter card (support via sideband cable) HDA routed to docking connector
ATA/Storage	4 SATA Ports	2 Cable Connector and 1 Direct Connect Connector, one eSATA connector Both port 0 & port 1 have interlock switch.
USB	12 USB 2.0/1.1 Ports	6 ports to Back-panel I/O connector, 5 ports to Front-panel I/O connector and 1 port to Docking
LPC	One LPC slot	Includes sideband headers
SMC/KBC	Hitachi H8S/2117 micro-controller Two PS/2 ports One scan matrix keyboard connector	ACPI compliant
Clocks	CK-505D system clock and DB800M	Three 133/166/200/233/400 MHz CPU differential clock pair Twelve 100MHz PCIe differential pair SRC clocks Twelve 33 MHz PCI clocks 48-MHz USB clock, 14-MHz ref clock, 96-Mhz Dot clock, Spread spectrum clocks
RTC	Battery-backed real time clock	
Thermal Monitoring	Processor temperature sensor	
Processor Voltage Regulator	Intel MVP-6+ for processor core	



	Description	Comments
Power Supply	Desktop Mode Mobile Mode	ATX Power Supply Battery Pack (smart battery support) Intel® Adaptive Mobile Power System (Intel® AMPS) AC Brick
Debug Interfaces	Port 80 display	Through Add-in card. Four seven-segment displays
	Extended Debug Port (XDP)	XDP connector (for processor run control) Test points for manageability engine JTAG LAI support
Intel® AMT support	Intel® Active Management Technology (Intel® AMT) is supported on the CRBs with M0 M1, and M-off management states	Controller Link to GMCH and to wireless LAN Manageability engine power plane
Intel® Turbo Memory Support	Intel® Turbo Memory technology of hardware cache is supported using an Intel Turbo Memory Add-in card	
Power Management	ACPI Compliant	C0, C1, C1E, C2, C2E, C3, C3E, C4E, slow C4 exit, Intel® Enhanced Deeper Sleep (with Level 5 read) and Deep Power Down Technology processor power states for mobility processors S0 (Power On), S3 (Suspend to RAM), S4 (Suspend to Disk), S5 (Soft Off) system power states. M0 (All Wells powered), M1 (Main Well down, Only ME power on), M-off (ME powered off) manageability power states
Form Factor	ATX 2.2 like form factor	10 layer board – 12” x 10.2”
Miscellaneous	Extended Battery Life (EBL) support Intel® Display Power Saving Technology (Intel® DPST) 4.0 support SPWG3.5 complaint LVDS panel support Mobile Digital Office initiatives TPM1.2 and support for Trusted Platform Enabling Intel AMT support Lead free design	



Note: Review the document provided with the Development Kit titled "Important Safety and Regulatory Information". This document contains safety warnings and cautions that must be observed when using this development kit.

3.4 Software Key Features

The driver CD included in the kit contains all software drivers necessary for basic system functionality under the following operating systems: Windows* XP/XP Embedded, Vista and Linux.

While every care was taken to ensure the latest versions of drivers were provided on the enclosed CD at time of publication, newer revisions may be available. Updated drivers for Intel components can be found at: <http://downloadcenter.intel.com>

For all third-party components, please contact the appropriate vendor for updated drivers.

Note: Software in the kit is provided free by the vendor and is only licensed for evaluation purposes. Refer to the documentation in your evaluation kit for further details on any terms and conditions that may be applicable to the granted licenses. Customers using the tools that work with Microsoft* products must license those products. Any targets created by those tools should also have appropriate licenses. Software included in the kit is subject to change.

3.4.1 AMI BIOS

This development kit ships with AMI* BIOS pre-boot firmware from AMI* pre-installed. AMI* BIOS provides an industry-standard BIOS on which to run most standard operating systems, including Windows* XP/XP Embedded, Linux*, and others.

The AMI* BIOS Application Kit (available through AMI*) includes complete source code, a reference manual, and a Windows-based expert system, BIOSStart*, to enable easy and rapid configuration of customized firmware for your system.

The following features of AMI* BIOS are enabled in the development board:

- DDR2 or DDR3 SDRAM detection, configuration, and initialization
- Intel® GM45 Express Chipset configuration
- POST codes displayed to port 80h
- PCI/PCI Express* device enumeration and configuration
- Integrated video configuration and initialization
- Super I/O configuration
- Active Management Technology
- RAID 0/1 Support



3.5 Thermal Management

The objective of thermal management is to ensure that the temperature of each component is maintained within specified functional limits. The functional temperature limit is the range within which the electrical circuits can be expected to meet their specified performance requirements. Operation outside the functional limit can degrade system performance and cause reliability problems.

The development kit is shipped with a heatsink thermal solution for installation on the processor. This thermal solution has been tested in an open-air environment at room temperature and is sufficient for development purposes. The designer must ensure that adequate thermal management is provided for if the system is used in other environments or enclosures.

3.6 System Features and Operation

The following sections provide a detailed view of the system features and operation of the development board.

3.6.1 Processor Support

The Pillar Rock board design supports the Intel® Core™ 2 Duo processor T9400 (U2E1) in a 478-pin Micro-FCPGA (Flip Chip Pin Grid Array) package.

3.6.2 Processor Voltage Regulators

The reference board implements an onboard Intel® Mobile Voltage Positioning (Intel® MVP) -6 regulator for the processor core supply. The core VR solution supports PSI2. The VR will support up to 44 amps. Slow C4 exit is supported to reduce perceptible audio noise caused by periodically exiting the C4 state.

3.6.3 Front-Side Bus (FSB)

The Front Side Bus (FSB) on the development board supports data rates of 667 MT/s (167MHz quad pumped, FSB-667), 800 MT/s (200MHz quad pumped, FSB-800) and 1067 MT/s (266 MHz quad pumped, FSB-1067). The FSB is AGTL+ and will be running at 1.05V.

3.6.4 Processor Power Management

Intel® Core™ 2 Duo processor T9400 supports C0-C6 power states. This processor also supports C2E and C4E. Additionally, the processor supports a new processor state, Intel Deep Power Down Technology, that brings the CPU leakage power down to the lowest possible. DPWR# protocol is also supported on the development board through signal H_DPWR#.



3.6.5 Processor Active Cooling

The system supports PWM based FAN speed control. Fan circuitry is controlled by the signal CPU_PWM_FAN signal from the EC (PWM signal from the H8 is driven high to 3.3 V and low to 0 V at about 40 kHz carrier frequency).

A 3-pin header J2B3 is provided to support FAN Tacho output measurement for the CPU.

3.6.6 Manual Processor Voltage ID (VID) Support

The development board supports manual VID operation for processor VR. A jumper J2B2 is provided to incorporate "VID override" to allow the overriding of CPU VID outputs to the CPU VCC Core VR. The intent of this "VID override" circuit is for ease of debug and testing.

3.6.7 Chipset

The Intel® GM45 Express Chipset (GM45 Chipset) is included on the development board. The chipset consists of the GM45 Graphics and Memory Controller Hub (GM45 GMCH) and the ICH9M I/O Controller Hub.

The Intel GM45 Express GMCH provides a processor interface at 667 MHz, 800 MHz or 1066 MHz and two DDR2 memory interfaces running at 667 or 800 MT/s. It supports internal graphics (integrated LVDS, two SDVO channels, VGA, TVO, Display port) as well as external graphics (through ADD-in card on a X16 PCI Express Graphics slot). It also supports a Intel Management Engine (Manageability JTAG signals brought to test point/8-pin header) and is connected to the ICH device via a DMI bus.

The ICH features:

- Twelve USB 2.0/1.1 compatible ports (Six back panel, five front panel USB ports and one port to docking)
- Four Serial ATA channels (two cable connects, one direct connect, one eSATA port)
- An Intel HD Audio digital link
- PCI 2.3 compliant interface (no slots on board, slots provided on Thimble Peak-2 card)
- LPC bus
- Six general purpose PCI Express 1.1a compliant lanes in which sixth PCI Express lane is used for Gigabit LAN interface.
- ICH9M also provides manageability support (controller link to GMCH and to wireless LAN).



3.6.8 System Memory

The development board supports dual-channel DDR2 interface. There are two DDR2 SO-DIMM sockets (J5P1 & J5N1). The GMCH supports four ranks of memory at 667 or 800MT/s on Pillar Rock CRB. The maximum amount of memory supported by Pillar Rock CRB is 8 GB of DDR2 memory by utilizing 2-Gb technology in stacked SO-DIMMs and 4 GB of DDR2 memory by utilizing 2-Gb technology in non-stacked SO-DIMMs. Minimum capacity supported is 256 MB using 512-Mb technology. There is no ECC support on Pillar Rock CRB.

3.6.9 Video Display

The development board has six options for displaying video: VGA, LVDS, TVOUT, SDVO, Display port (through Add in card) or PCI Express Graphics (PEG). Display port, SDVO and PCI Express Graphics (PEG) are multiplexed on the same pins within the chipset. The development board contains one DP/SDVO/PCI Express Graphics Slot (J6B2) for a PCI Express compatible graphics card or an SDVO compatible graphics card (ADD2N & ADD2R), one LVDS connector (J6F1), one TV-OUT D-connector (J2A1), and one 15-pin VGA connector (J2A2). To support ADD2R (with PCI graphic lanes reversed), resistor R1U4 should be made "NO STUFF".

By default the voltage supplied to the SDVO/PCI Express Graphics slot is switched off in suspend mode, and the reset signal is not gated. A stuffing option allows the voltage to be supplied from voltage rails that stay on in suspend mode. A different stuffing option allows the reset signal to be gated as well. Details of these stuffing options are on sheet 19 of the Pillar Rock schematics.

The TV is output through a D-connector. There are two cables in order to access TV: a black D-connector to S-video (IPN: C87694-001) and a black D-connector to 3 pin component (IPN: C87695-001). The blue coax pin can be used for composite TV interface. To use a non-high definition external display with the board, change the resolution to 480 lines interlaced (480i) in the Internal Graphics Device properties.

Table 7. TV-Out Connections

	D-connector Cable	
Composite Video	Blue	
Component Video	Cable	TV
	Red	Red
	Green	Green
	Blue	Blue
S-Video	D-connector to S-video	

Note: Composite video and component video both use the same cable.



3.6.10 PCI Express Slots

The ICH9M I/O Controller Hub (ICH9M) provides 6 PCI Express ports (x1). Port 6 is multiplexed with Gigabit LAN Controller Interface. The reference board has five x1 PCIe slots (J6B1, J6D1, J8B3, J8D1 & J7B1). Three of the five slots, Slot 1, Slot 3, and Slot 5, are located at standard expansion slot locations. The fourth and fifth slots, Slot 2 and Slot 4, are located in-line with Slot 1 and Slot 3 respectively.

Support for x2 on lane 1 and lane 2 (Port 1 can be configured as a x1 port or a x2 port shared with port 2) and on Lane 3 and lane 4 (port 3 can be configured as a x1 port or a x2 port shared with port 4) can be configured via the ICH9M "RPC – Root Port Configuration" register.

Table 8. PCI Express Ports

ICH9M PCIe Port	Default Destination	Optional Destination
1	PCIe Slot 1 (J6B1)	PCIe Docking (1 st lane)
2	PCIe Slot 2 (J6D1) (in-line with Slot 1)	PCIe Docking (2 nd lane)
3	PCIe Slot 3 (J8B3)	
4	PCIe Slot 4 (J8D1) (in-line with Slot 3)	C-link south routed to this slot. WLAN card support through Upham3 Add-in card
5	PCIe Slot 5 (J7B1)	
6 (GLCI)	Intel 82567 LAN	Muxed with PCIe slot5 (only for testing)

Note: Slot4 also supports controller link. Upon a net detect event, Slot 4 gets a switched Auxiliary 3.3 V supply.

3.6.11 PCI Slots

The reference board does not have any PCI slots on the motherboard. Three 5V PCI slots are supported via the Thimble Peak PCI Extension Card.

3.6.11.1 PCI Gold-Fingers

A gold-finger connector (S9B1) is also supplied on the development board, which allows an external PCI expansion board, Thimble Peak 2, to connect to it. Thimble Peak 2 has three additional PCI slots allowing the user greater expansion. See [Appendix A](#) for more information on the Thimble Peak 2 add-in card.

3.6.12 On-Board LAN

The development board provides 10/100/1000 LAN through EU8A1. Intel ® 82567 is used on the reference board. The 82567 component is connected to the ICH9M chipset through the LAN Connect Interface (LCI) and supports 10/100Mbps link. The same device is connected through GLCI interface and supports 1000Mbps link. 82567 connect to an RJ45 connector at J5A1 with built in magnetic decoupling.



3.6.13 Serial Peripheral Interface (SPI)

The Serial Peripheral Interface on ICH9M can be used to support two compatible flash devices (U8C1 (or U8B2), U8C4 (or U8C3)). Both the SPI devices supports for multi-package (SOIC-8 and SOIC-16) device. The SOIC-8 package (U8C1 & U8C4) would support 16 Mb SPI flashes, while the SOIC-16 package (U8B2 & U8C3) will support 32Mb or higher SPI flash. Unified BIOS code (BIOS+ IAMT+ LAN) resides in these two SPI devices.

Note: Out of the SOIC-8 and SOIC-16 footprints supported on the board only one of these can be used at a time and on the board the Footprint is arranged one over the other. By default, U8C1 (16Mb on CS#0) and U8C4 (16Mb on CS#1) will be stuffed.

Note: SPI programming details are given in Section 2.8.2

3.6.14 Soft Audio/Soft Modem

Intel® High Definition Audio functionality is enabled through the Mott Canyon 4 Daughter Card. ICH9M supports 4 Intel® High Definition Audio codec. All the four are routed to MDC header through resistor stuffing option. By default Codec 0 & 1 will be connected to MDC Card. An on-board header is provided at J9E2 and J9E4 for this purpose. No direct connection is provided for the Intel® High Definition Audio Card on the development board; the Mott Canyon 4 card is required to enable the Intel® High Definition Audio functionality. See [Appendix A](#) for more information on the Mott Canyon 4 card.

The development board supports low voltage (LV) High definition codecs I/O. R8E7, R8E8 & R7H2, R7H3 resistors are used to select between 3.3V I/O and 1.5V I/O.

Table 9. Selection of I/O Voltage for the High Definition Audio

I/O Voltage for the High Definition Audio	STUFF	NO STUFF
3.3V (Default)	R8E7, R7H3	R8E8, R7H2
1.5V	R8E8, R7H2	R8E7, R7H3

3.6.15 SATA Storage

The development board provides four serial ATA (SATA) connectors. One of the four serial ATA (SATA) connectors is a “direct connect” connector located at J8J1 (port 0 from ICH9M). The other two serial ATA connectors are “cable connect” connectors located at J6J3 (port 1 from ICH9M) & J6J2 (port 4 from ICH9M). Also, the development board supports an eSATA connector located at J7J1 (port 5 of ICH9M). The eSATA connector is available on the front edge of the board.

Additionally SATA port 4 can be made available at docking connector by stuffing (C7W2, C7W3, C7V13 and C7V14) and making C7H1, C7H2, C7G9 and C7G8 to “NO STUFF”.



Table 10. SATA Ports

SATA Port	Connection Type	Connector
Port 0	Direct Connect	J8J1
Port 1 & Port 4	Cable Connect	J6J3 & J6J2
Port 5	eSATA	J7J1

These connectors mentioned in [Table 10](#) are for the serial data signals. The board has a power connector J5J1 to power the serial ATA hard disk drive. A green LED at CR7H1 indicates activity on the ATA channel.

The development board shares the power connector for both SATA ports. Due to this only one of the serial ATA channel (Port1 by default) supports hot swapping capability. Hot swap on Port 1 can be used only when the Port 4 is not used. Y-Power cable needs to be connected first to the device on Port 1 before connecting the signal cable. When hot swap is not desired, both Port 1 and Port 2 can be used. A jumper J7H1 is provided to enable hot plug/removal on port-1. For jumper setting details refer to Section 4.3.1, Table 17.

Note: The eSATA drives should be externally powered. Hence, there is no power supply support for them on the motherboard

3.6.16 USB Connectors

ICH9M provides a total of twelve USB 2.0/1.1 ports. 6 USB ports (0, 2, 4, 6, 8, 10) are connected to the back-panel I/O connector, 6 ports (1, 3, 5, 7, 9, 11) to the front-panel I/O connector (of these ports, port 9 is also routed to Docking).

Four ports (0, 2, 4, and 6) are routed to a 4 stacked USB connector (J3A1) at the back panel. The other 2 ports (8 and 10) are routed to the RJ45+Dual USB stacked connector (J5A1) at the back panel.

Six USB ports are routed to USB 2X5 front panel headers: Port (1, 3) at J6H4, Port (5, 7) at J6H2 and Port (9, 11) at J6J1. The remaining one USB port is routed to docking connector J9C2.

Note: The USB Port 9 is routed to the docking station interface by default. By changing the straps near ICH9M Port 9 can be routed to the front panel header also. The advantage of this scheme is that Port 9 can be tested on the Motherboard without using the docking card.

Table 11. USB Ports mapping

USB Port	Panel	Connector
Port 0, Port2, Port4, Port 6	Back Panel I/O Connector	J3A1 (4 stacked USB Connector)
Port 1 & Port 3	Front Panel I/O Header	J6H4
Port 5 & Port 7	Front Panel I/O Header	J6H2
Port 8 & Port 10	Back Panel I/O Connector	J3A1 (RJ45 with Dual USB Connector)



USB Port	Panel	Connector
Port 9 & Port 11	Front Panel I/O Header (port 9 is routed to J6J1 through strapping option)	J6J1
Port 9	Docking Connector (default)	J9C2

3.6.17 LPC Super I/O (SIO)/LPC Slot

A SMSC SIO1007 serves as the SIO on the development board and is located at U7E3. Shunting the jumper at J7E1 to the 2-3 positions can disable the SIO by holding it in reset. This allows other SIO solutions to be tested in the LPC slot at J8E1. A sideband header is provided at J9G1 for this purpose. This sideband header also has signals for LPC power management. Information on this header is on sheet 43 of the Pillar Rock schematics and is detailed in the “LPC Slot and Sideband Header Specification” (document #14159).

3.6.18 Serial, IrDA

The SMSC SIO chip incorporates a serial port, and IrDA (Infrared), as well as general purpose IOs (GPIO). The Serial Port connector is provided at J2A2, and the IrDA transceiver is located at U6A1. The IrDA transceiver supports SIR (slow IR), FIR (Fast IR) and CIR (Consumer IR). The option to select between these is supported through software and GPIO pin (IR_MODE) on the SIO.

3.6.19 Intel® 82802 Firmware Hub Device Support

It should be noted that the development board does not include an Intel 82802 Firmware Hub Device. Intel 82802 Firmware Hub Device support is provided through the TPM header (J9A1). A Port 80 card with an Intel 82802 Firmware Hub Device assembled can be used.

3.6.20 System Management Controller (SMC)/Keyboard Controller (KBC)

A Renesas* H8S/2117 (U9G2) serves as both System Management Controller (SMC) and Keyboard Controller (KBC) for the development board. The SMC/KBC controller supports two PS/2 ports, battery monitoring and charging, wake/runtime SCI events, CPU thermal monitoring/Fan control, GMCH thermal throttling support, LPC docking support and power sequencing control.

The two PS/2 ports on the development board are for legacy keyboard and mouse. The keyboard plugs into the bottom jack and the mouse plugs into the top jack at J1A1. Scan matrix keyboards can be supported via an optional connector at J9E1.



3.6.21 Clocks

The system clocks and spread spectrum clocks are provided by the CK505D (EU6H1) clock synthesizer.

The FSB frequency is determined from decoding the processor BSEL settings. The BSEL settings can be manually changed via jumpers J1G5, J1G3, and J1G1 (Refer to Table 17).

The development board also supports PCIE CLKREQ through the DB800 SRC clock buffer (U7C2). In addition this CRB also supports one dual 1x8 PCI fan-out buffer (U7E4)

3.6.22 Real Time Clock

An on-board battery at BT5H1 maintains power to the real time clock (RTC) when in a mechanical off state. A CR2032 battery is installed on the development board.

3.6.23 Thermal Monitoring

The processor has a thermal diode for temperature monitoring (the thermal sensor is located at U3B3). The SMC throttles the processor if it becomes hot. If the temperature of the processor rises too high, the SMC alternately blinks the CAPS lock LED (located at CR9G2) and NUM lock LED (located at CR9G1) on the board, and the board shuts down.

The development board supports PWM based FAN speed control. As part of the thermal measurement, speed of the fan is varied based on the temperature measurement. 3-pin fan headers J2B3 and J3C2 are provided to support FAN Tacho output measurement for CPU and GMCH respectively.

3.6.24 Power Supply Solution

The development board has the option to be powered from three different power sources; an ATX power supply, an AC/DC switching power supply ('Mobile Brick'), or up to 2 external batteries. The board contains all of the voltage regulators necessary to power the system up. There are two main supported power supply configurations, Desktop and Mobile. The Desktop solution consists of only using the ATX power supply. The Mobile solution consists of using the Mobile iAMPS AC Brick in conjunction with the batteries. When the Mobile solution is being used either AC brick or batteries can be plugged in. When both AC brick and the batteries are connected at the same time, the batteries are monitored and charged if necessary.

Warning: Do not mix mobile and desktop power configurations. Unplug the ATX power supply from connector J4J1 before plugging in the AC to DC Power Adapter to connector J1G9, or a battery (not included) to connector J1H1-J1H2

Note: Desktop peripherals, including add-in cards, will not work in mobile power mode. If desktop peripherals are used, the platform must be powered using desktop power mode.



Note: Please use an "ATX12V" 1.1 Spec compliant power supply regardless of Vendor or wattage level (an "ATX12V" rating means V5 min current =0.1 A, "ATX" V5 min current = 1.0 A, among other differences). For example, the Sparkle Model No. FSP300-60BTVS meets this requirement and is an ATX12V 1.1 Spec compliant power supply.

Note: This development board uses the Intel AMPS solution for AC brick. For more details refer to Intel® Adaptive Mobile Power System (Intel® AMPS) White Paper (Doc #603714) available from your Intel Representative

Note: If power button on the ATX power supply is used to shut down the system, please wait at least 5 seconds before turning the system on again. We do not recommend shutting down the system this way.

3.6.25 Manual VID support for Graphics VR

The development board supports manual VID operation for graphics Voltage Regulator. Jumper J2H2 is provided to incorporate "VID override" to allow the overriding of GMCH VID outputs to the graphics VR. The intent of this "VID override" circuit is for ease of debug and testing. VID settings are contained in the IMVP6+ Specification (*RS – Intel® IMVP-6 Mobile Processor and Mobile Chipset Voltage Regulation Specification*). Contact your Intel representative for access to this document.

3.6.26 Debug Interfaces

An XDP (Extended Debug Port) connector is provided at J1F1 for processor run control debug support. This connector is compatible with both XDP and ITP-700. An external adapter is used to interface ITPFlex700 cable to the platform. XDP incorporates new run-control features on the JTAG interface and allows the user to communicate with the processor or GMCH.

A port 80-83 display add-in card can also be used for debug. The port 80-83 add in card could be used on the TPM header located at J9A1

Note: The XDP interface is backwards compatible with the ITP interface. However, an XDP to ITP converter cable is necessary to use the older ITP tools. Also, in some cases a resistor change rework is necessary to get the older ITP tools to function properly. Please contact an Intel representative for additional details.

3.6.27 Board Form-Factor

The reference board form factor is similar to the full-size ATX specification and uses 10 layer board – 12" x 10.2".



3.7 Power Management

3.7.1 Power Management States

Table 12 and Table 13 list the power management states that have been defined for the development board. The system's Controller Link (CL) operates at various power level, called the M-states. M0 is the highest power state, followed by M1 and M-off.

Table 12. System Power Management States

State	Description
G0/S0/C0	Full on
G0/S0/C2	Quick Start: STPCLK# signal active
G0/S0/C3	Deep Sleep: CPUSTP# signal active
G0/S0/C4-C6	Deeper Sleep: Voltage to processor core is lowered (feature enabled by software)
G1/S3	Suspend To RAM (all switched rails are turned off)
G1/S4	Suspend To Disk
G2/S5	Soft Off
G3	Mechanical Off

Table 13. System Power Management M-States

M States	System States	Power Wells	DRAM	ME Clocking
M0	S0	All wells powered	Powered	Clock chip powered and PLL, DLL in use
M1	S3-S5	Main well down	In self refresh; ME DRAM controller on using Channel A	Clock Chip powered with only the GMCH clock running and PLL, DLL in use
M-off	S3-S5	Main well down	Powered off (or self refresh)	None, ME powered off

The development board also supports CLKRUN#.

3.8 Testability

The development board provides an Extended Debug Port (XDP) for testing at J1F1 and direct processor probing. The XDP interface is backwards compatible with the older ITP interface as well. The user must use an XDP or ITP interface that is compatible with the Intel® Core™ 2 Duo processor T9400.

Note: The XDP interface is backwards compatible with the ITP interface. However, an XDP to ITP converter cable is necessary to use the older ITP tools. Also, in some cases a



resistor change rework is necessary to get the older ITP tools to function properly. Please contact your Intel representative for additional details.

3.9 Power Measurement Support

Power measurement resistors are provided on the platform to measure the power of most subsystems. All power measurement resistors have a tolerance of 1%. The value of these power measurement resistors are 2mΩ by default. Power on a particular subsystem is calculated using the following formula:

$$P = \frac{V^2}{R}$$

R = value of the sense resistor (typically 0.002Ω)

V = the voltage difference measured across the sense resistor.

It is recommended that the user use a high precision digital multi-meter tool such as the Agilent 34401A digital multi-meter. Refer to [Table 14](#) for a comparison of a high precision digital multi-meter (Agilent 34401A) versus a standard precision digital multi-meter (Fluke 79).

Table 14. Digital Multi-Meter Comparison

EXAMPLE SYSTEM			
Sense Resistor Value:		0.002Ω	
Voltage Difference Across Resistor:		1.492 mV (746 mA)	
Calculated Power:		1.113 mW	
Agilent 34401A (6 ½ digit display)		Fluke 79 (3 digit display)	
Specification:	(±0.0030% of reading) + (±0.0030% of range)	Specification:	±0.09% ±2 digits
Min Voltage Displayed:	1.49193 mV	Min Voltage Displayed:	1.47 mV
Calculated Power:	1.1129 mW	Calculated Power:	1.08 mW
Max Voltage Displayed:	1.49206 mV	Max Voltage Displayed:	1.51 mV
Calculated Power:	1.1131 mW	Calculated Power:	1.14 mW
Error in Power:	±0.009%	Error in Power:	±0.3%

As [Table 14](#) shows the precision achieved by using a high precision digital multi-meter versus a standard digital multi-meter is ~33 times more accurate.

[Table 15](#) summarizes all the power measurement sense resistors located on the board. All sense resistors are 0.002Ω unless otherwise noted. Reference designators marked with an asterisk are “not stuffed” on the board.

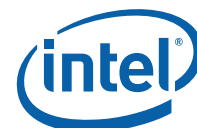

Table 15. System Voltage Rails

Component/ Interface	Voltage Plane	Supply	Rail	Reference Designator
CPU VR	5V	+V5S	+V5S_IMVP6	R1B1
CPU VR	Battery	+VBAT	+VDC_PHASE	R1P5
CPU VR	1.05V	6262_PHASE1	+VCC_CORE	R3D1
CPU VR	1.05V	6262_PHASE2	+VCC_CORE	R2D1
CPU	1.05V	+V1.05S	+V1.05S_CPU	R3U2 & R3U1
CPU	1.5V	+V1.5S	+VCCA_PROC	R3R13 (0.01Ω)
GMCH VR	Battery	+VBATA	1.05S_VIN	R4G3
GMCH VR	Battery	+VBATA	1.05M_VIN	R4V10
GMCH VR	Battery	+VBATA	1.5S_VIN	R5V5
GMCH VR	Battery	+VBAT	GVR_VBAT	R3V2
GMCH VR	5 V	+V5S	+V5S_GVR	R3F5
GMCH VR	3.3V	+V3.3S_TVDAC	+V3.3S_A_TV_DAC	R4F3
GMCH VR	1.05 V	51124_LL2_L	+V1.05M	R4F7
GMCH VR	1.05 V	51124_LL1_L	+V1.05M	R4G4
GMCH VR	Battery	+VBATA	1.05S_VIN	R4G3
GMCH	1.05 V	+V1.05M	+VCC_GMCH	R5U3
GMCH	VCCP (1.05 V)	+V1.05M	+VCCP_GMCH	R4F5
GMCH	1.05 V	+V1.05M	+V1.05M_PEG_LR	R6E3
GMCH	1.05 V	+V1.05M	+VCC_DMI	R5E1
GMCH	V_GFX (1.05S)	+VCC_GFXCORE	+VGFX_CORE	R3F2
GMCH	1.05 V	+V1.05M_CANTIGA	+V1.05M_A_SM_CK	R4R2
GMCH	1.05 V	+V1.05M_CANTIGA	+V1.05M_PEGPLL	R5T8
GMCH	1.05 V	+V1.05M_CANTIGA	+V1.05M_MCH_PLL	R4D6
GMCH	1.05 V	+V1.05M_CANTIGA	V1.05M_MCH_PLL2	R5F14
GMCH	1.05 V	+V1.05M_CANTIGA	+V1.05M_A_SM	R4R2
GMCH	1.5 V	+V1.5S	+V1.5S_TVDAC	R4U3
GMCH	1.5 V	+V1.5	+V1.5_DDR2_GMCH	R4D1
GMCH	1.8 V	+V1.5_DDR2_GMCH	+V1.8_SM_CK_RR	R4D1
GMCH	1.8 V	+V1.8S	+V_TXLVDS_PM	R5F4
GMCH	1.8 V	+V1.8S	+V1.8_DLVDSD	R5F8
GMCH	3.3 V	+V3.3S	+V3.3S_HV	R5F1
GMCH	1.5 V	+V1.5S	+VCC_HDA	R5U1



Development Board Features

Component/ Interface	Voltage Plane	Supply	Rail	Reference Designator
GMCH	3.3 V	+V3.3S_A_TV_CRT_BG	+V3.3S_A_DAC_BG	R5F6
GMCH	3.3 V	+V3.3S_A_TV_CRT_BG	+V3.3S_A_TV_DAC	R4F3
PCIE Gfx	3.3 V	+V3.3	+V3.3S_PEG	R6P2*
PCIE Gfx	3.3 V	+V3.3S	+V3.3S_PEG	R6C1
PCIE Gfx	Battery	+VBATS_S4	+V12S_PEG	R6N6*
PCIE Gfx	Battery	+VBATS	+V12S_PEG	R6N9
ICH	1.05 V	+V1.05S	+V1.05S_ICH	R7F5
ICH	1.05 V	+V1.05S	+V1.05S_ICH_IO	R6V10
ICH	1.5 V	+V1.5S	+V1.5S_PCIE_R	R6G3
ICH	1.5 V	+V1.5S	+V1.5S_SATA_ICH	R7G16
ICH	1.5 V	+V1.5S	+V1.5S_USB_ICH	R7H1
ICH	3.3 V	+V3.3S	+V3.3S_DMI_ICH	R6G6
ICH	3.3 V	+V3.3S	+V3.3S_GLAN_ICH	R6U9
ICH	3.3 V	+V3.3M_WOL	+V3.3M_ICH	R7U7
ICH	3.3 V	+V3.3A	+V3.3A_ICH	R6F9
ICH	3.3 V	+V3.3A	+V3.3A_USB_ICH	R7G1
ICH	3.3 V	+V3.3S	+V3.3S_VCCPCORE_ICH	R7G14
ICH	3.3 V	+V3.3M_WOL	+V3.3M_VCCPAUX	R7F2
ICH	3.3 V	+V3.3S	+V3.3S_PCI_ICH	R7F4
ICH	3.3 V	+V3.3S	+V3.3S_SATA_ICH	R7G9
Memory	Battery	+VBATA	1.8_VIN	R54A4
Memory	0.9 V	+V0.9	+V0.9_R	R4B10
Memory	1.8 V	+V1.5	+V1.5_DIMM0	R5C3
Memory	1.8 V	+V1.5	+V1.5_DIMM1	R5B6
Memory	3.3 V	+V3.3M	+V3.3M_DIMM0	R4C1 (0.022Ω)
Memory	3.3 V	+V3.3M	+V3.3M_DIMM1	R4B23 (0.022Ω)
LAN	3.3 V	+V3.3M_LAN_SW	+V3.3M_LAN	R7A2
LAN	1.8 V	+V1.8_LAN	+V1.8_LAN_M	R8A11
LAN	1 V	+V1.0_LAN_M	+V1.0_LAN_M_IN	R8A3
PCI	12 V	+V12S	+V12S_PCI	R8B1
PCI	3.3 V	+V3.3S	+V3.3S_PCI	R9D2
PCI	5 V	+V5S	+V5S_PCI	R9B2
PCI	5 V	+V5	+V5_PCI	R8B3



Component/ Interface	Voltage Plane	Supply	Rail	Reference Designator
PCIE	12 V	+V12S	+V12S_PCIESLOT1	R7N6
PCIE	12 V	+V12S	+V12S_PCIESLOT2	R7C20
PCIE	12 V	+V12S	+V12S_PCIESLOT3	R8B2
PCIE	12 V	+V12S	+V12S_PCIESLOT4	R8C3
PCIE	12V	+V12S	+V12S_PCIESLOT5	R7N2
PCIE	3.3 V	+V3.3S	+V3.3S_PCIESLOT1	R7N5
PCIE	3.3 V	+V3.3S	+V3.3S_PCIESLOT2	R7R1
PCIE	3.3 V	+V3.3S	+V3.3S_PCIESLOT3	R7C1
PCIE	3.3 V	+V3.3S	+V3.3S_PCIESLOT4	R8D2
PCIE	3.3 V	+V3.3S	+V3.3S_PCIESLOT5	R7N4
Audio	1.5 V	+V1.5A_HDA_IO	+V3.3S_1.5S_HDA_IO	R8E8*
Audio	3.3 V	+V3.3A	+V3.3A_1.5A_HDA_IO	R8E7
Panel Bklt	5 V	+V5S	+V5S_LVDS_BKLT	R6U20
Panel Bklt	Battery	+VBAT	+VCC_LVDS_BKLT	R6F15
Panel LVDS	3.3 V	+V3.3S/+V5S	VDD_VDL	R6V2
Panel LVDS	3.3 V	+V3.3S	+V3.3S_LVDS_DDC	R6U19*
CK505	3.3 V	+V3.3M	VDD_CK505	R5V12
CK505	3.3 V	+V3.3S	+V3.3S_DB800	R7C9
CK505	1.05 V	+V1.05M	+VDDIO_CLK	R5V8
LPC	3.3 V	+V3.3	+V3.3_LPCSL0T	R8F1
LPC	5 V	+V5	+V5_LPCSL0T	R8E3
TPM	5 V	+V5	+V5_R1_TPM	R9M1
TPM	3.3 V	+V3.3S	+V3.3S_R1_TPM	R9M2
TPM	3.3 V	+V3.3A	+V3.3A_R1_TPM	R9A3
SMC	3.3 V	+V3.3A	+V3.3A_KBC	R8H8
PS2	5 V	+V5	+V5_PS2	R1A1
SIO	3.3 V	+V3.3S	+V3.3S_SIO	R7T2
IR	3.3 V	+V3.3S	+V3.3S_IR	R4M3
USB	5 V	+V5A	+V5A_USBPWR_IN4	R7H15
USB	5 V	+V5A	+V5A_USBPWR_IN3	R3B3
USB	5 V	+V5A	+V5A_USBPWR_IN2	R7H5
USB	5 V	+V5A	+V5A_USBPWR_IN1	R5W15
SPI	3.3 V	+V3.3M_WOL	+V3.3M_SPI	R6R1
SATA	3.3 V	+V3.3S	+V3.3S_SATA_P0	R8Y1



Component/ Interface	Voltage Plane	Supply	Rail	Reference Designator
SATA	5 V	+V5S	+V5S_SATA_P0	R8H12
SATA	12 V	+V12S	+V12S_SATA_P0	R8W14
SATA	3.3 V	+V3.3S	+V3.3S_SATA_P1	R6J3
SATA	5 V	+V5S	+V5S_SATA_P1	R4Y4
SATA	12 V	+V12S	+V12S_SATA_P1	R4Y3
System	Battery	+VCHGR_OUT	+VBS	R1G12 (0.02Ω)
System	Battery	AMPS_AD+_Q1	+VBS	R2H1 (0.007Ω)
System	Battery	+VBATA	51120_DRVH1_+VBATA_Q	R3H18
System	Battery	+VBATA	51120_DRVH2_+VBATA_Q	R3H3
System	3.3 V	51120VBST2_LR	+V3.3A_MBL	R3G5
System	5 V	51120_+V5A_MBL_QL	+V5A_MBL	R3J2
System	ATX	+V5A	+V5_ATX	R4J1*
System	ATX	+V3.3A	+V3.3_ATX	R4W21*
System	ATX	+V12_ATX	+VBATA	R4Y2
System	ATX	-V12_ATX	-V12A	R4Y1
System	ATX	+V5SB_ATX	+V5SB_ATXA	R5H8

3.10 Power Supply Usage and Recommendation

Do not use non-Sparkle ATX power supplies. Only use Sparkle ATX Desktop Power Supplies.

As the Desktop ATX supplies grew to meet the increased power for those Motherboards, their minimum loading requirements also grew. When you try to run a mobile platform on it, it may not load the 5.0V rail enough to meet the minimum loading requirements for it to maintain regulation.

Recommended power 20-pin ATX power supplies include:

Sparkle Model No. FSP300-60BTVS meets this requirement and is an ATX12V 1.1 Spec (note that this part may be End Of Life)

These 20-pin ATX power supplies may also work if you can't find the above model number (lower power supplies are probably better):

Sparkle (SPI) FSP250-60BT, FSB300-60BT, FSB300-60BTV, FSP350, FSP400-60GN (these supplies work in the lab, although are not checked against spec)

DO NOT use Delta or PowerMan ATX Supplies. You may experience the following symptoms when using a non-Sparkle supply.

- "post 00"

Development Board Features



- Blue Screen reporting driver or device issue when using a desktop PCI graphics card
- Hanging during boot with PEG or PCI graphics
- PCI video only during boot, but not available after in Windows.

§



4 *Development Board Physical Reference*

4.1 Board Components

The following figure shows the major components of the Pillar Rock development board, and Table 16 gives a brief description of each component.



Figure 2. Pillar Rock Development Board Components

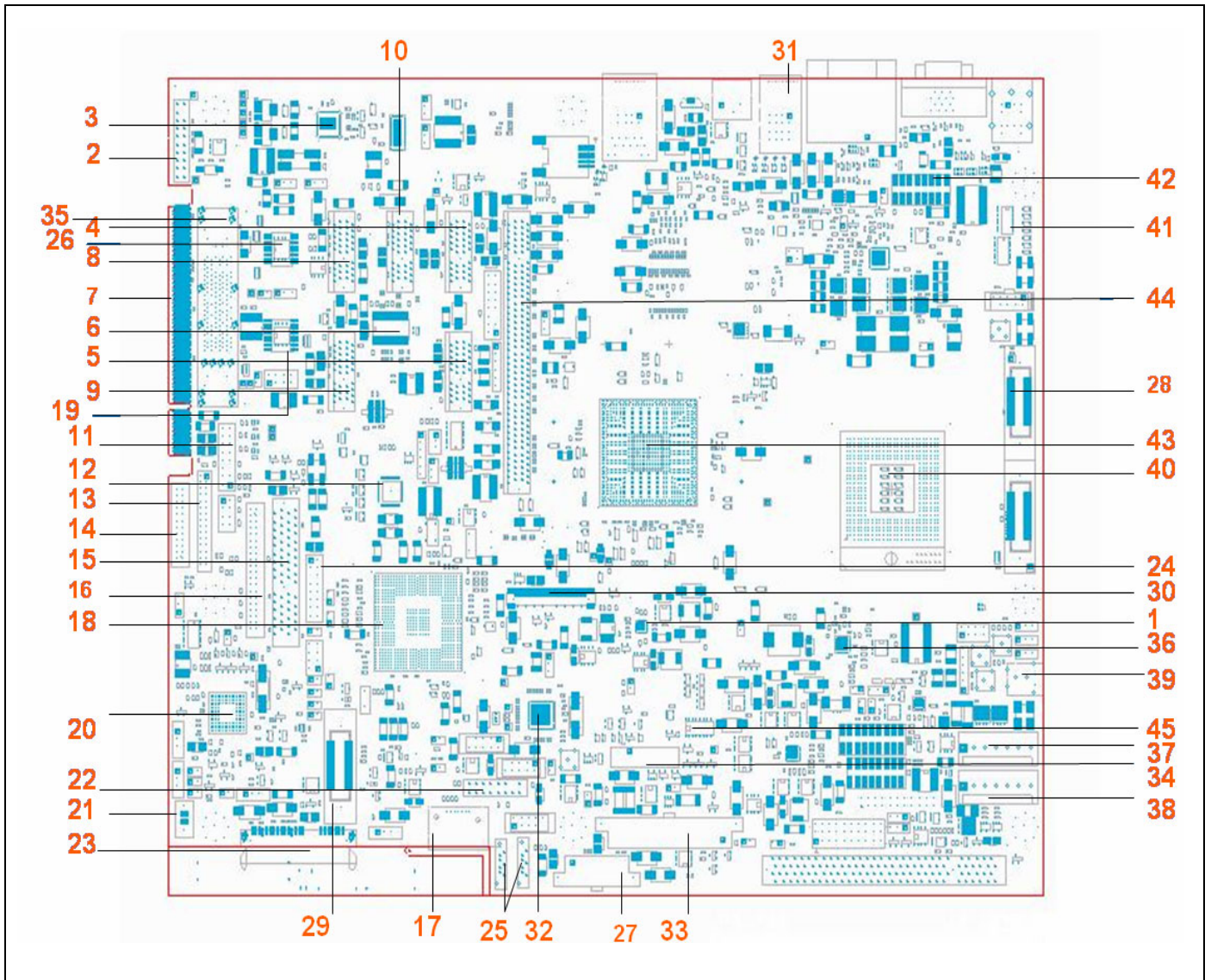

Table 16. Pillar Rock Development Board Components

Location	Description	Reference Designator
1	Chipset VR	EU5G1
2	Trusted Platform Module	J9A1
3	Intel 82567 LAN controller	EU8A1
4	PCI Express Slot 1	J6B1
5	PCI Express Slot 2	J6D1
6	DB800 Clock Buffer	U7C2



Location	Description	Reference Designator
7	PCI Gold-Fingers	S9B1
8	PCI Express Slot3	J8B3
9	PCI Express Slot4	J8D1
10	PCI Express Slot5	J7B1
11	Mott Canyon - 4 Header	J9E2
12	SMSC SIO	U7E3
13	Keyboard Scan Matrix	J9E1
14	LPC Docking Connector	J9E3
15	LPC Sideband Header	J9G1
16	LPC Slot	J8E1
17	eSATA connector	J7J1
18	ICH9M	U7F1
19	SPI flash 1	U8C4
20	SMC/KBC	J1A1
21	RSVD	J9J1
22	Virtual Battery Switch	SW9H3
23	SATA Direct Connect	J8J1
24	Front Panel Header	J6H5
25	SATA Cable Connect	J6J3 & J6J2
26	SPI Flash 2	U8C1
27	SATA Port1,4 Power Connector	J5J1
28	Debug XDP - CPU	J1F1
29	RSVD	
30	LVDS Connector	J6F1
31	Front Panel USB	J6H4 & J6H2 & J6J1
32	CK-505 Derivative	EU6H1
33	ATX Power Supply Connector	J4J1
34	RTC Battery	BT5H1
35	Docking connector	J9C2
36	Graphics VR	EU3G1
37	Battery B Connector	J1H2
38	Battery A Connector	J1H1
39	Intel AMPS connector	EU2G1
40	Penryn	U2E1



Location	Description	Reference Designator
41	VID LEDs	CR1B1 CR1B2 CR1B3 CR1B4 CR1B5 CR1B6 CR1B7
42	Manual VID Override Jumper	J2B2
43	Intel 4 Series Express chipset	U5E1
44	PCI Express Graphics Slot	J6B2
45	DDR2 VR	EU4N1

4.2 Connectors

Caution: Many of the connectors provide operating voltage (+5V DC and +12V DC, for example) to devices inside the computer chassis, such as fans and internal peripherals. Most of these connectors are not over-current protected. Do not use these connectors for powering devices external to the computer chassis. A fault in the load presented by the external devices could cause damage to the computer, the interconnecting cable, and the external devices themselves. This section describes the board's connectors.

4.2.1 Back Panel Connectors

Figure 3 shows the back panel connectors on the board.

Figure 3. Back Panel Connectors

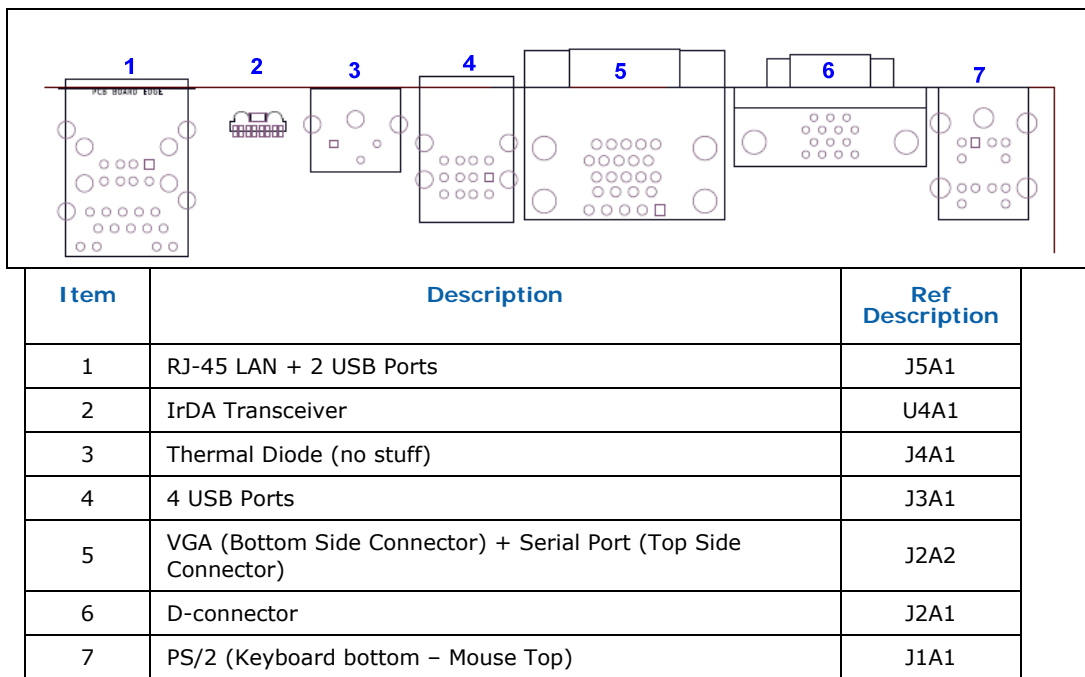

Note: The on-board 14 pin D-Connector J2A1 (#6) supplies the necessary signals to support the Composite, S-Video, and Component TV standards. Component video and composite video are connected to the development board using a D-connector to component video cable (with three RCA receptacles at one end and D-mating connector on other end) (not included in the kit). S-video is connected to the board using a D-connector to S-Video cable (with 4-pin DIN connector one end and D-mating connector on other end) (not included in the kit).

Figure 4. D-Connector to Component Video Cable

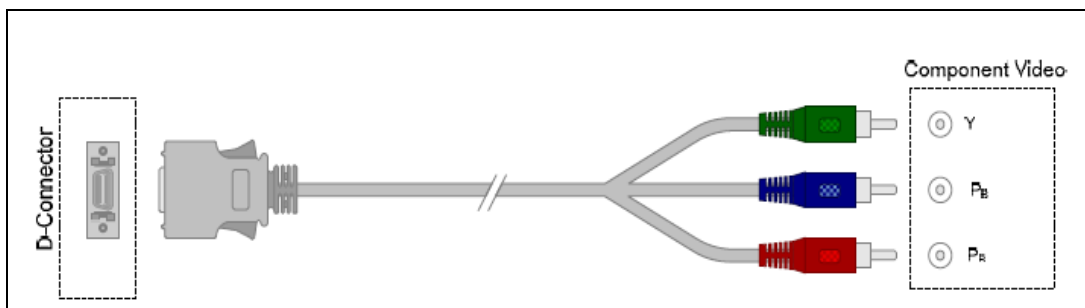

Figure 5. D-Connector to Composite Video Cable

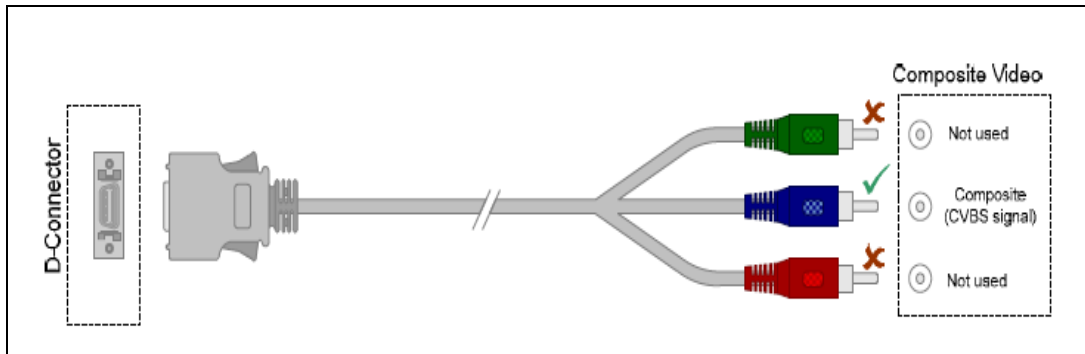
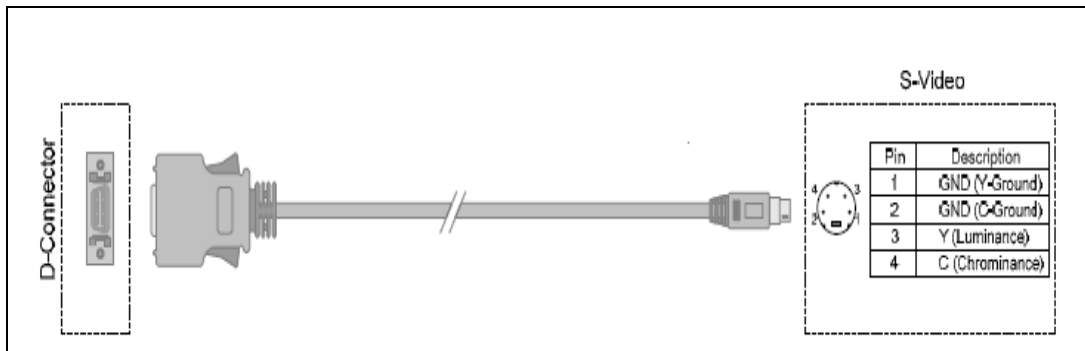

Figure 6. D-Connector to S-Video Cable



4.3 Configuration Settings

4.3.1 Configuration Jumpers/Switches

Caution: Do not move jumpers with the power on. Always turn off the power and unplug the power cord from the computer before changing jumper settings. Else, it may damage the board.

Note: Some jumpers may fall off during shipment. Jumpers that are only attached to one pin (noted as 1-x) are more prone to becoming detached. Replacing detached 1-x jumpers is not required for proper board operation.

[Figure 7](#) shows the location of the configuration jumpers and switches. [Table 17](#) summarizes the jumpers and switches and gives their default and optional settings. The board is shipped with the jumpers and switches shunted in the default locations.

Figure 7. Location of the Configuration Jumpers/Switches

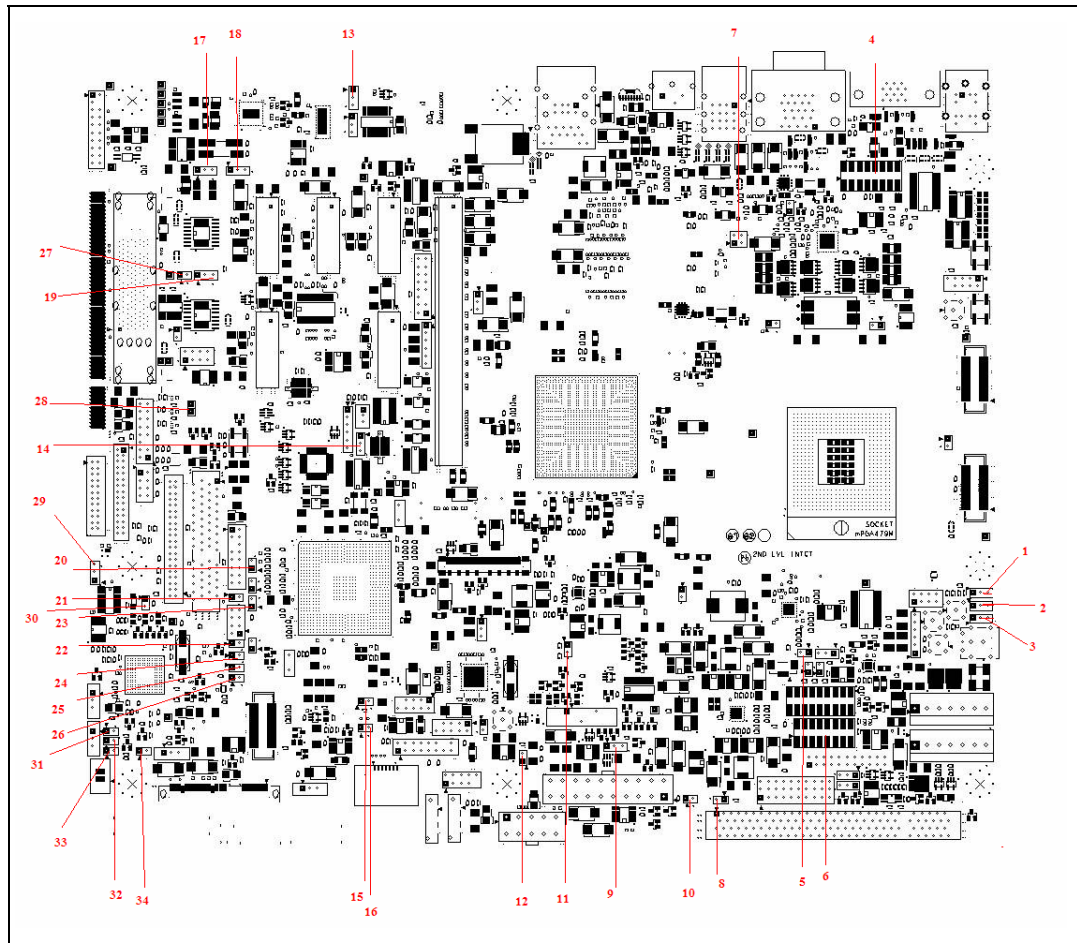

Table 17. Configuration Jumper/Switches Settings

No.	Reference Designator	Description	Default Setting	Optional Setting
1	J1G1	BSEL2 (Refer to BSEL section for Setting Changes)	1-2	1-X
2	J1G3	BSEL1 (Refer to BSEL section for Setting Changes)	1-2	1-X
3	J1G5	BSEL0 (Refer to BSEL section for Setting Changes)	1-2	1-X
4	J2B2	CPU CORE VID	All OPEN (CPU)	
5	J2G1	Force Shutdown	1-X (Normal Operation)	1-2 Force the board to shutdown
6	J2H2	GFX CORE VID	All OPEN	
7	J3C1	CPU thermal sensor	1-2, 3-4	



No.	Reference Designator	Description	Default Setting	Optional Setting
8	J3J2	Power-on Latch	1-X (Normal Operation)	1-2 Latch the power-on
9	J4H1	No Intel Management Engine G3 to M1 support	1-X	1-2 Jump power state from G3 to M1
10	J4J2	SATA Power Enable	1-2 (Hot plug/removal supported)	1-X Hot plug not supported
11	J5G1	SRTC RST	1-X (Keep Intel Management Engine RTC registers)	1-2 Clear Intel Management Engine RTC registers
12	J5H2	CMOS Clear	1-X (Normal Operation)	1-2 Clear the contents of the CMOS
13	J7A1	In-circuit SMC Programming	1-2 (Normal Operation)	2-3 To Program the H8
14	J7E1	SIO Reset	1-2 (Normal Operation)	2-3 To hold the SIO in RESET
15	J7H1	SATA interlock switch for port0	1-2 (Present)	1-X Removed
16	J7H2	TPM PHYSICAL PRESENCE	1-X (Not Present)	1-2 (Present)
17	J8B1	PM LAN enable	1-2 (LAN Enable)	2-3 LAN Disable
18	J8B2	In-circuit SMC Programming	1-2 (Normal Operation)	2-3 To Program the H8
19	J8C1	SELCETING SPI0 or SPI1 TO BE PROGRAMMED	1-X (No device selected for Programming)	1-2 SPI-0 to be programmed enabled 2-3 SPI-1 to be Programmed enabled
20	J8F2	BIOS recovery	1-X (Normal Operation)	1-2 for BIOS recovery
21	J8G3	SMC MD2	1-X	1-2 Advanced single chip mode
22	J8G5	SMC MD1	1-2 (Normal Operation)	1-X No external programming
23	J8G6	KBC disable	1-X (KBC enabled)	1-2 KBC disabled
24	J8H1	Boot BIOS Strap	1-2	1-X PCI to LPC
25	J9C1	PROGRAMMING SPI1	1-X	1-2 Program SPI-0



No.	Reference Designator	Description	Default Setting	Optional Setting
26	J9D1	PROGRAMMING SPI0	1-X	1-2 Program SPI-1
27	J9F1	KSC Enable	1-2	1-X
28	J9G2	Boot Block Programming	1-2 (Normal Operation)	1-X to Program the H8
29	J9H1	NMI	1-X	1-2 Disabled
30	J9H2	SATA interlock switch for port1	1-2 (Present)	1-X Disabled
31	J9H3	LID Position	1-X	1-2
32	J9H4	Virtual Battery	1-X	1-2

Note: A jumper consists of two or more pins mounted on the motherboard. When a jumper cap is placed over two pins, it is designated as 1-2. When there are more than two pins on the jumper, the pins to be shorted are indicated as 1-2 (to short pin 1 to pin 2), or 2-3 (to short pin 2 to pin 3). When no jumper cap is to be placed on the jumper, it is designated as 1-X.

4.3.2 BSEL Jumper Settings

The jumper settings in Table 18 are provided to accommodate frequency selection for the processor Power On and Reset Push Buttons.

Table 18: BSEL Jumper Settings

		Processor
		Intel® Core™ 2 Duo processor (Penryn)
FSB Speed (MHz)	CPU Driven	J1G5 → 1-2 J1G3 → 1-2 J1G1 → 1-2
	1067	J1G5 → Open J1G3 → 2-3 J1G1 → 2-3
	800	J1G5 → open J1G3 → open J1G1 → 2-3
	667	J1G5 → 2-3 J1G3 → Open J1G1 → 2-3

4.4 Power and Reset Push Buttons

The development board has two pushbuttons: Power and Reset. The Power button releases power to the entire board causing the board to boot. The Reset button forces all systems to warm reset. The two buttons are located near the CPU close to the East edge of the board. The Power button is located at SW1C1 and the Reset button is located at SW1C2.

Table 19. Power-On and Reset Push buttons

Description	Component
Power Button	SW1C1
Reset Button	SW1C2
CPU	U2E1

Figure 8. Power On and Reset Buttons

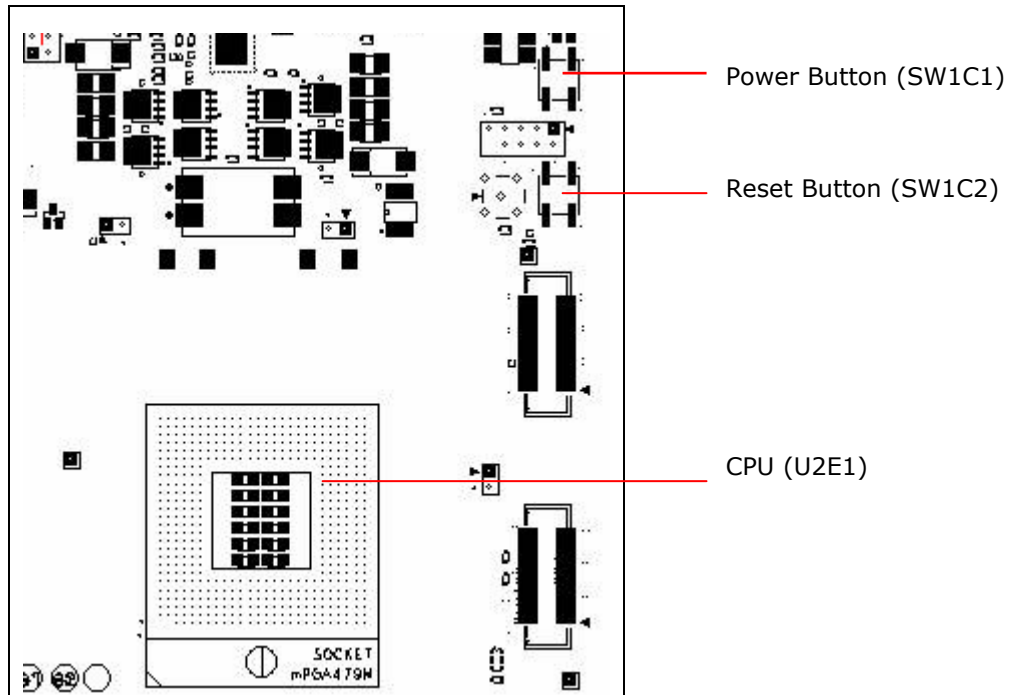

4.5 Net Detect Button

The board has one Net Detect push button switch (SW8E1) to support wireless LAN network detection in S0-S5. This button is connected on the SMC/KBC GPIO. When pressed, a manageability wake event is signaled to the ICH9M via SMC/KBC, manageability planes are powered, and the 82567 wireless LAN performs the network detection.

Figure 9. Net Detect Button

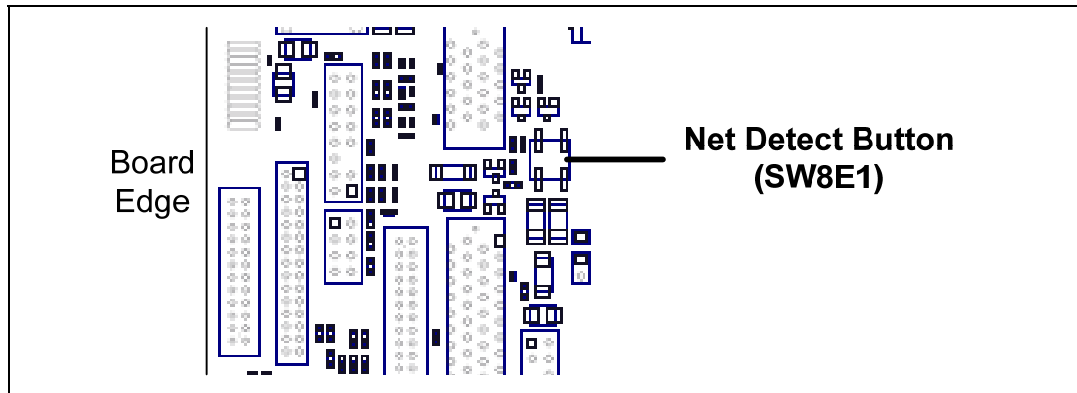

4.6 LEDs

The following LEDs provide status of various functions on the development board.

Table 20. LEDs

Function	Reference Designator
Keyboard number lock	CR9G1
Keyboard scroll lock	CR9G3
Keyboard caps lock	CR9G2
System State S0	CR5H4
System State S3	CR5H6
System State S4	CR5H7
System State S5	CR5H5
System State M0/M1	CR5H3
SATA Activity	CR7H1
VID Setting 0	CR1B1
VID Setting 1	CR1B2
VID Setting 2	CR1B3
VID Setting 3	CR1B4
VID Setting 4	CR1B5
VID Setting 5	CR1B6
VID Setting 6	CR1B7
System Power Good	CR7H3
LT Status	CR8G1



4.7 Other Headers

4.7.1 H8 Programming Headers

The microcontroller firmware for system management/keyboard/mouse control can be upgraded in two ways. The user can either use a special DOS* utility (in-circuit) or use an external computer connected (remote) to the system via the serial port on the board.

If the user chooses to use an external computer connected to the system via the serial port, there are four jumpers that must be set correctly first. Please refer to [Table 21](#) for a summary of these jumpers and refer to

[Figure 7](#) for the location of each jumper.

Required Hardware: One Null Modem Cable and a Host Unit with a serial COM port (System used to flash the SUT)

Here is the sequence of events necessary to program the H8.

1. Extract all files (keep them in the same folder) to a single directory of your choice on the host machine or on a floppy disk
2. Connect a NULL modem cable to the serial ports of each platform (host and unit to be flashed).
3. With the board powered off, move the following jumpers to the programming stuffing option.
4. J9G2 (remove) (default: 1-2), Sets SMC_INIT_CLK high.
5. J7A1 (2-3) (default: 1-2), link the Host Unit to On Board H8.
6. J8B2 (2-3) (default: 1-2), link the Host Unit to On Board H8.
7. J9H1 (1-2) (default: 1-X), disable 1 Hz Clock.
8. Attach an AC brick or an ATX power supply to the system and power up the board.
9. From the directory where you extracted the files, run the "kscflash ksc.bin / remote" command to program the H8 via the serial port.
10. Follow the instructions the flash utility provides.
11. With the board powered off, return the jumpers to their default setting.

Note: Make sure the board is not powered on, and the power supply is disconnected before moving any of the jumpers.



Table 21. H8 Programming Jumpers

#	Jumper	Reference Designator	Default Stuffing Option	Programming Stuffing Option
1	Remote H8 Programming	J7A1 J8B2	1-2 – normal operation	2-3 – link the Host Unit to On Board H8
2	Boot Block Programming	J9G2	1-2 (IN) – normal operation	OUT – set SMC_INIT_CLK high (to program H8)
3	1Hz clock	J9H1	OUT – normal operation, clock enabled	IN – clock disabled, enable H8 programming

4.7.2 Sideband and Test Headers

Additional sideband and test headers are located on sheet 43 of the Pillar Rock schematics.

§



Appendix A Add-In Cards

Of the add-in cards described in this appendix, only the Port 80-83 Card, PCI Expansion Card (Thimble Peak 2) and the HDMI and Display Port Video Interface Card (Eaglemont) are included in the development kit. Contact your Intel Representative to obtain cards not included in the kit.

A.1 Port 80-83 Add-in Card (Included)

Port 80-83 Add-in card plugs to the CRB through TPM header. It also provides an additional 10 pin LPC header for LPC supported interfaces. Port80-83 card decodes the LPC bus BIOS POST codes and displays on four 7-segment display. It also has optional Intel® 82802 Firmware Hub Device footprint for BIOS support.

Figure 10. Port 80-83 Interposer Card

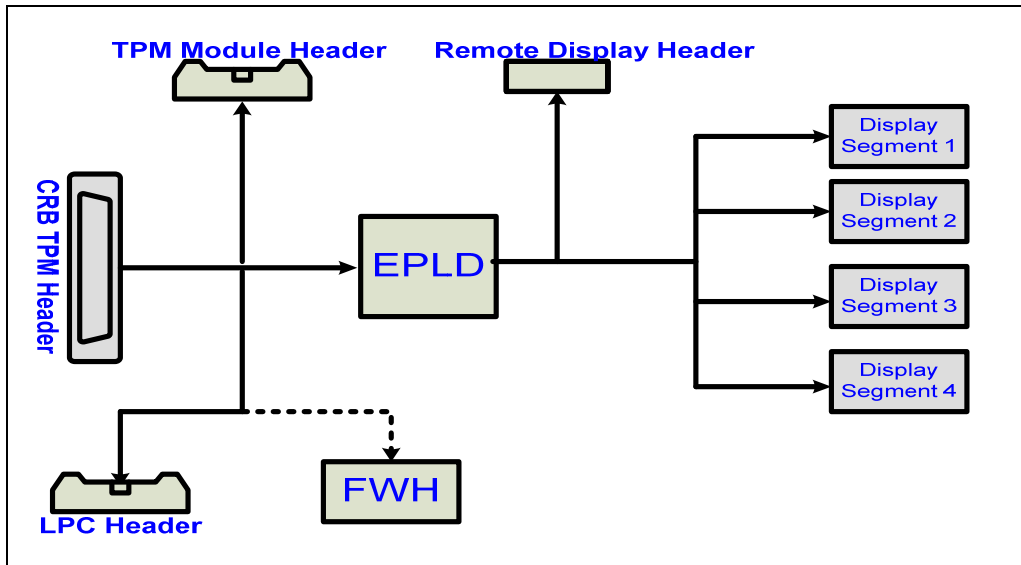

Jumper J1 is used for the following configurations:

Table 22. Port 80-83 Display Configurations

Jumper J1	Description
Open (None)	AIC Intel® 82802 Firmware Hub Device Disabled Display Ports 81-80
1-2	AIC Intel® 82802 Firmware Hub Device enabled Display Ports 81-80
2-3	AIC Intel® 82802 Firmware Hub Device Disabled

	Display Ports 83-82
--	---------------------

A.2 PCI Expansion Card (Thimble Peak 2) (Included)

The PCI Expansion Card (Thimble Peak 2) is provided to offer 3 PCI slots and one goldfinger PCI slot on the evaluation board. The expansion card also contains a floppy disk drive connector, parallel port connector, and a serial port connector. To connect the card, slide the horizontal PCI connector on Thimble Peak 2 onto the gold-fingers on the development board. To connect the LPC bus enabling the floppy disk drive connector, parallel port connector, and a serial port connector, connect the ribbon cable as depicted in [Figure 11](#). CLKRUN protocol is supported on Thimble Peak 2 board for only those PCI cards which support CLKRUN#, else CLKRUN# should be disabled in BIOS.

Upon boot up, the system BIOS automatically detects that the PCI expansion card is present and connected to the system. The system BIOS then performs all needed initialization to fully configure the expansion card. For additional information see the LPC docking connector on the evaluation board schematics.

Figure 11. PCI Expansion Card (Thimble Peak 2)

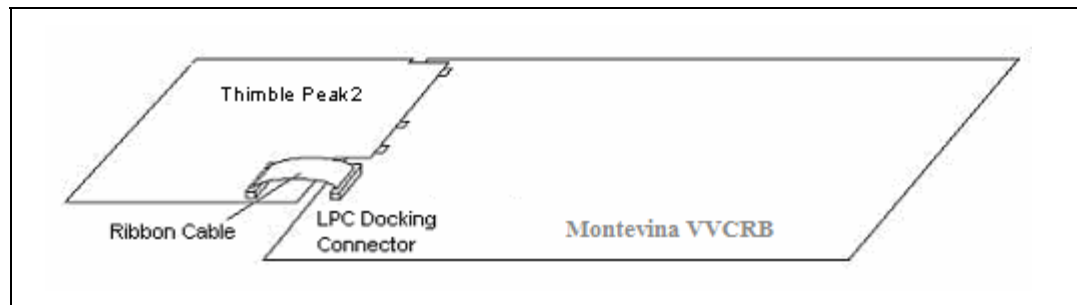

A.3 HDMI and Display Port Video Interface Add-In Card (Eaglemont) (Included)

Eaglemont is an Add-In Card (AIC) for testing and validating Display Port and HDMI interfaces supported by the GM45 GMCH. The Display Port/HDMI signals are multiplexed over PCIe signals of GMCH and are routed to a x16 PCIe slot on the respective motherboards. This AIC is an interposer which routes these signals to Display Port/HDMI connectors. The AIC supports the following connectors:

- Two Display Port external connector or two HDMI connectors
- One embedded Display Port connector.



Figure 12. Eaglemont Add-in Card

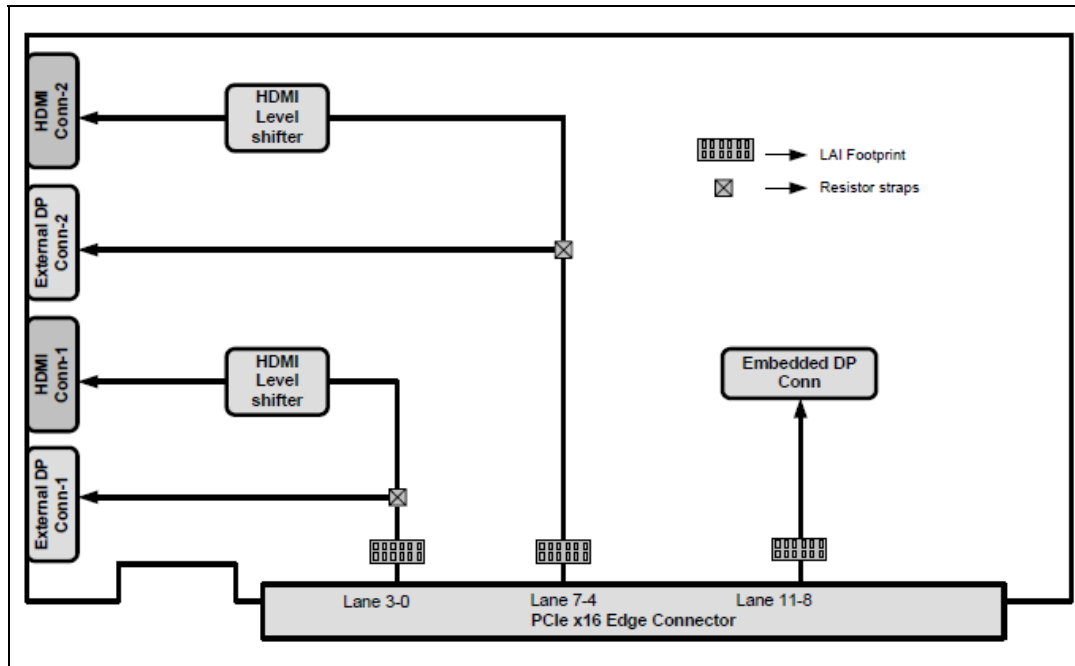

A.3.1 Rework to change Eaglemont card from HDMI to Display Port

Note: All rework should use lead-free solder in order to keep the board RoHS compliant.

1. Resistors R5D7, R5D5, R5D3, R5C19, R5C16, R5C12, and R5C11 need to be taken off and placed in the ref des. R5D6, R5D4, R5D, R5C18, R5C17, R5C14, R5C13, and R5C10. In the picture below the highlighted areas show where the resistors should end up. Move the vertically-mounted resistors horizontally.

Figure 13. Location of Resistors for Rework (before Rework)

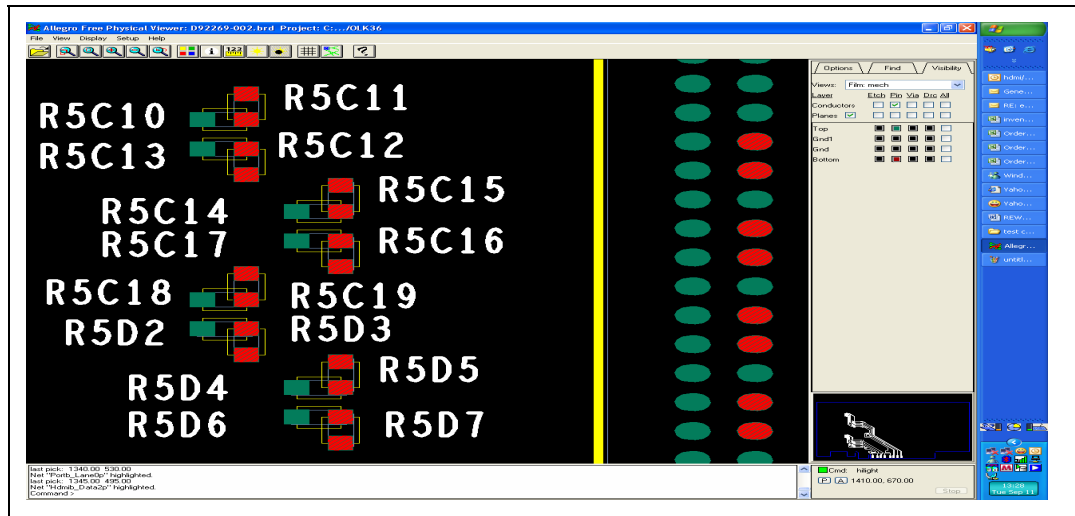
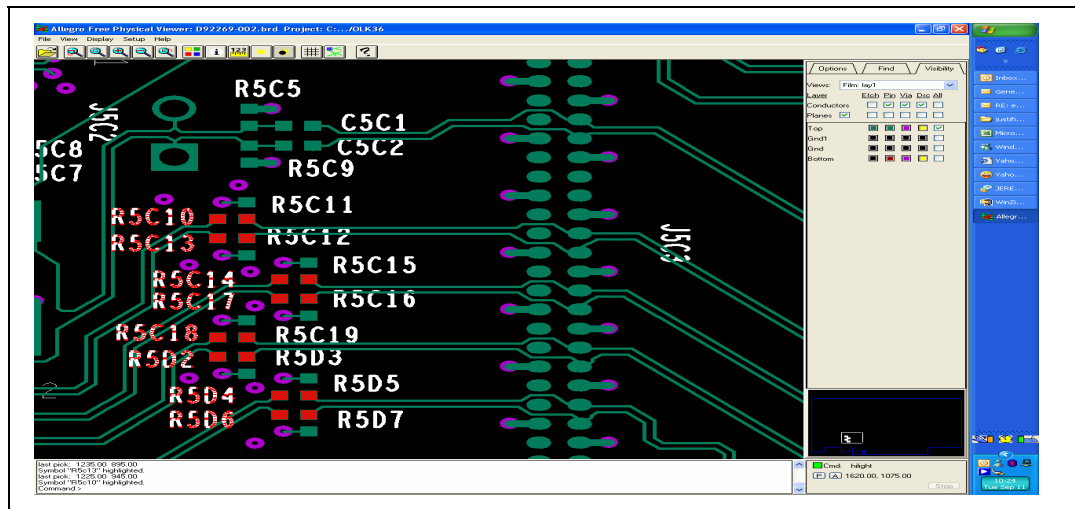

Figure 14. Location of Resistors for Rework (after Rework)



2. On the mid/upper left hand section of Eaglemont card, resistor locations R5B22, R5B19, R5B18, R5B16, R5B14, R5B11, R5B9, and R5B6 can be identified. As mentioned in the procedure above these resistors need to be taken off and assembled them in the ref. des. R5B21, R5B20, R5B17, R5B15, R5B13, R5B10, R5B8, and R5B7. Refer the pictures below for resistor location before and after rework. As mentioned in the procedure above, the vertically mounted resistors need to be removed and assembled horizontally on designated pads.



Figure 15. Location of Resistors for Rework

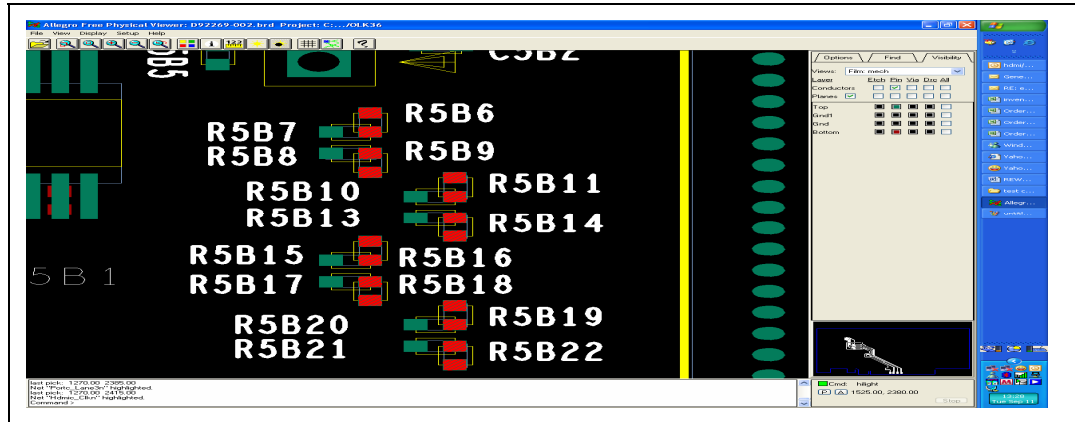

A.3.2 AUX Pull Down Rework.

All Eaglemont cards (both Fab1 and Fab2) as delivered from the factory have 100 k Ω pull-up resistors on AUXP and AUXN. These cards should be re-worked so that there are 100 k Ω pull-downs on all AUXP and AUXN signals. There are only pull-downs on AUX.

Eaglemont cards that are to be used for Display Port require this re-work. This is independent of any other re-works required.

In the figure below, the resistors are incorrectly pulling up to 3.3V when they should be pulling to GROUND.

Note: All rework should use lead-free solder in order to keep the board RoHS compliant.

Figure 16. AUX Pull-Down Rework

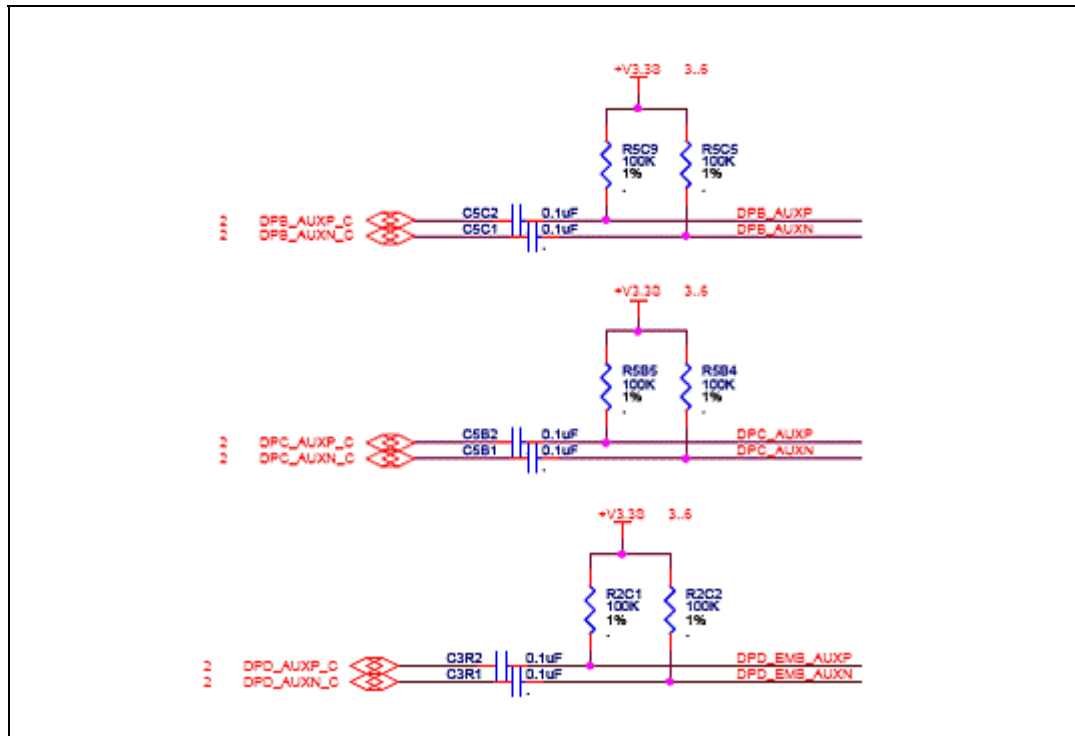

The resistors are:

- Port B: R5C9 and R5C5
- Port C: R5B5 and R5B4
- Port D: R2C1 and R2C2

A.4 Intel® High Definition Audio Interposer Card (Mott Canyon 4) (Not Included)

The Mott Canyon 4 (MC4) Interposer Card is provided to enable Intel® High Definition Audio (Intel® HD Audio) and modem functionality on the development board. .Mott Canyon 4 provides two 30-pin MDC1.0 connectors and one 12-pin MDC1.5 connector, supporting up to two Intel HD Audio codecs simultaneously. The Interposer plugs into any PCIExpress or PCI slot for mechanical stability and is electrically connected to the platform via a 2x13 ribbon cable from the Mott Canyon 4 card to a 2x8 header (J8E1) and 2x4 header (J8E2). Headers on Mott Canyon 4 are provided for both modem and audio sideband signals. MC4 provides four audio jacks and one modem jack. A set of four more audio jacks may be added by using the MC4 paddle card. MC4 paddle card also provides one jack each for S/PDIF IN and S/PDIF OUT. For additional information see sheet 24 of the Pillar Rock schematics. A diagram of the MC4 interposer and paddle card on a platform is shown in Figure 17.



Figure 17. Mott Canyon 4 Interposer Card

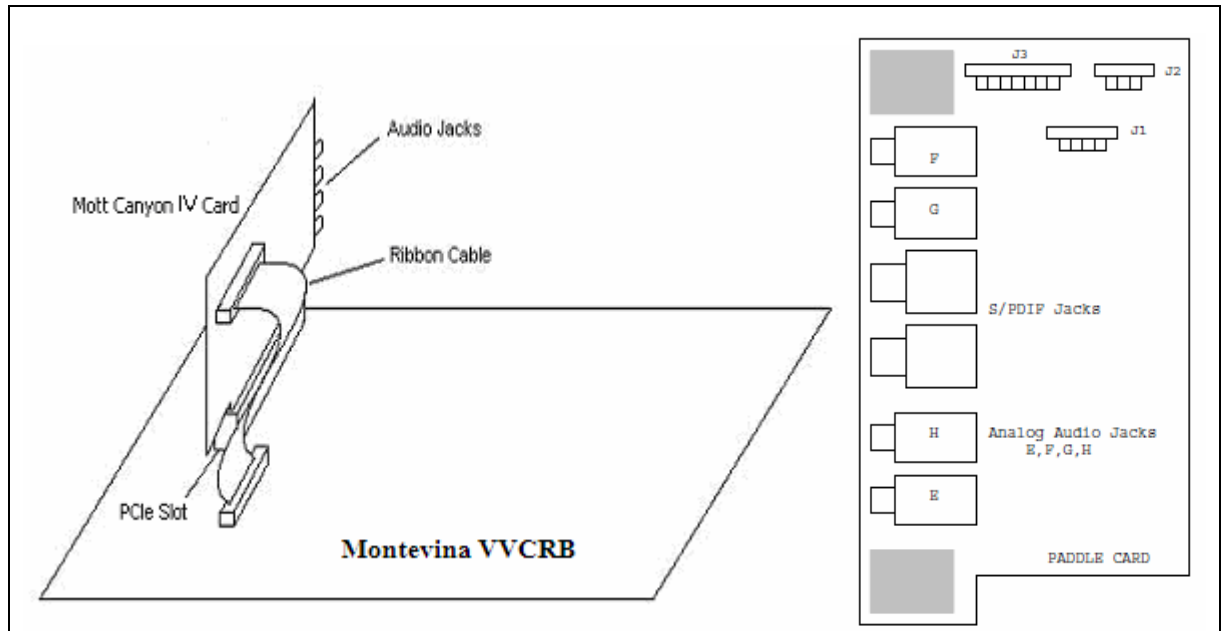

A.4.1 Mott Canyon 4 Jumper Settings

The Mott Canyon 4 Interposer has the ability to select either Primary or Secondary Intel HD Audio functionality for MDC0 and MDC1 connectors with two jumper options, J16 and J25. See Table 23 below for details. MDC2 supports an Intel® High Definition Audio modem-only codec.

The ICH9M supports up to 4 SDATA_IN channels (0, 1, 2 & 3). MC4 supports three channels (0, 1 & 2) of codecs. Mapping of four ICH9M channels on MC4 card can be done using strapping resistors on the development board. Three jumpers: J27, J28, and J29 are used to select the appropriate SDATA_IN channel for MDC. The default and optional mapping of SDATA_IN signals are shown in the following Table 21. Please be aware that SDATA_IN channels 1 and 2 can also be overridden via jumpers on the evaluation platform. If either SDATA_IN1 or SDATA_IN2 are not shunted properly on the evaluation platform, these lines will not be available to the Mott Canyon 4 Interposer Card. Proper operation of the Intel HD Audio interface requires that only one SDATA_IN line to be routed to one codec at a time.

Table 23. Mott Canyon 4 Configuration Jumper/Switches Settings

#	Description	Default Setting	Optional Setting	Reference Designator
1	ACZ_SD_0 Destination (MDC-0-1-2)	1-2 for MDC0 codec A	3-4 for MDC0 codec B 5-6 for MDC1 codec A 7-8 for MDC1 codec B 9-10 for MDC2 codec A	J27
2	ACZ_SD_1 Destination (MDC-0-1-2)	5-6 for MDC1 codec A	1-2 for MDC0 codec A 3-4 for MDC0 codec B 7-8 for MDC1 codec B	J28



#	Description	Default Setting	Optional Setting	Reference Designator
			9-10 for MDC2 codec A	
3	ACZ_SD_2 Destination (MDC-0-1-2)	9-10 for MDC2 codec A	1-2 for MDC0 codec A 3-4 for MDC0 codec B 5-6 for MDC1 codec A 7-8 for MDC1 codec B	J29
4	MDC0 Primary Jumper	1-2 for secondary	2-3 for primary	J16
5	MDC1 Primary Jumper	1-2 for secondary	2-3 for primary	J25
6	3.3V Power Option	1-2 for mobile	2-3 for desktop	J24
7	5.0V Power Option	2-3 for desktop	1-2 for mobile	J32
8	MDC0 Docking Emulation (Switch Enable)	1-2 for OFF	2-3 for ON	J33
9	MDC0 Docking Emulation (DOCK_RST#)	1-2 for Normal	2-3 for Docking Emulation	J26



A.5 ExpressCard Module Interposer (Duck Bay 3) (Not Included)

The Duck Bay 3 Interposer Card is a modular add-in card based on the PCI Express and USB interfaces. Duck Bay 3 is provided to enable both 34 mm and 54 mm ExpressCard functionality on the Pillar Rock development board. To support the PCI Express interface, Duck Bay 3 plugs into PCI Express slot 0 (J8C1) and PCI Express slot 2 (J8D1) on the board. To support the USB interface Duck Bay 3 plugs into the USB front panel header (J6H4). Please refer to [Figure 18](#) for a pictorial representation of how Duck Bay 3 attaches to the development board.

Figure 18. Duck Bay 3 Interposer Card

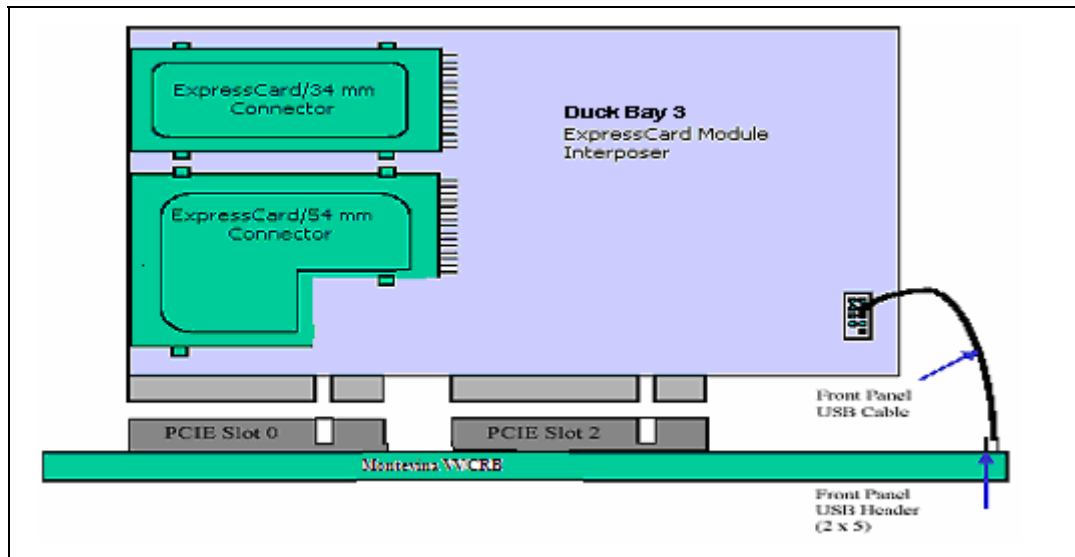

A.6 PCI Express mini card Interposer (Upham IV) (Not Included)

The Upham IV board plugs into the PCI Express slots on The development board. It supports the attachment of two independent PCI Express mini cards (Complied with Express mini card specification Rev1.0) with USB connection enabled for each. The USB interface is implemented using a separate cabling scheme. The interposer supports a Bluetooth module and allows the concurrent usage of Bluetooth and PCI Express mini cards. The interposer supports any specific feature that may be required for the PCI Express mini card WLAN product.

This interposer supports the SIM card functionality for the purpose of testing WWAN modules.

Figure 19. Upham IV Interposer Card

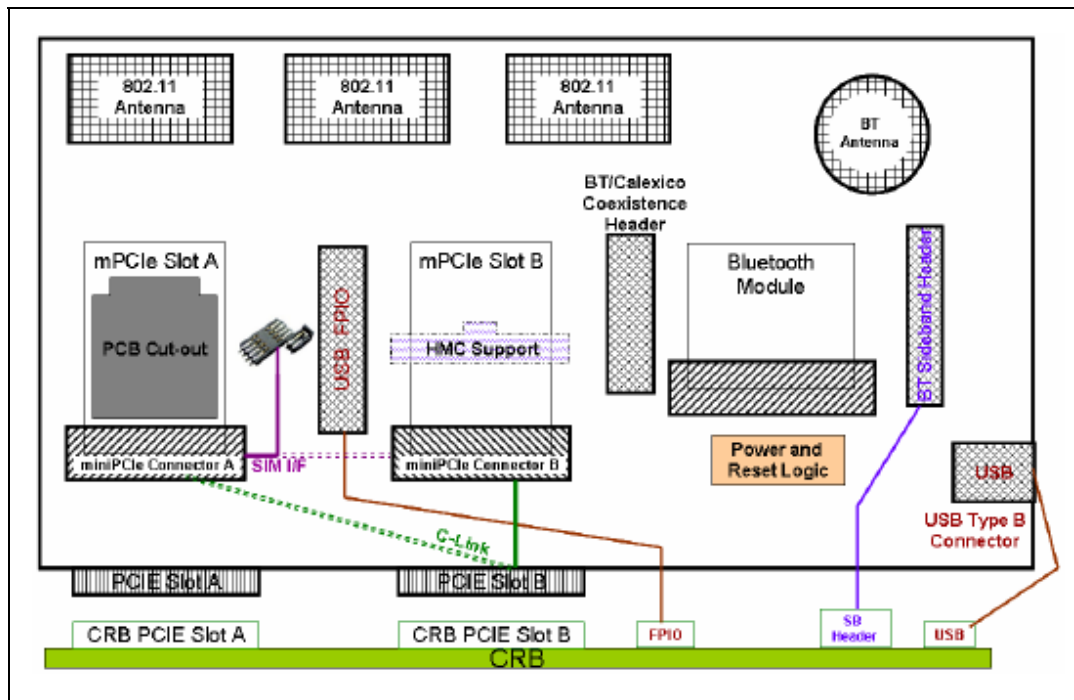

Table 24. Upham IV default Jumper/Switches Settings

Jumper Ref Des	Default Setting	Description	Other options
J1B1	1-2	Power to BT LDO from USB	Open (1-X) – Power Disabled
J4C1	1-X	Channel data to Slot2	Closed (1-2) – Enable slot 2 Channel Data to BT through Opamp
J2C1	2-3	H/W Shutdown for BT	Closed (1-2) – H/W Shutdown enable for BT



Jumper Ref Des	Default Setting	Description	Other options
J4C2	1-X	BT clock to Slot2	Closed (1-2) – Enable slot 2 Clock to BT clock through Opamp
J7D1	1-2	V3.3_aux or V3.3 select for mini PCIE slot 1 1-2 – V3.3_aux 2-3 – V3.3	Closed (1-2): V3.3_aux Closed (2-3): Select V3.3
J4D1	1-X	V3.3_aux or V3.3 select for mini PCIE slot 2 1-2 – V3.3_aux 2-3 – V3.3	Closed (1-2): V3.3_aux Closed (2-3): Select V3.3
J6C1	1-X	Channel data to slot0	Closed (1-2) – Enable slot 1 Channel Data to BT through op amp
J6C2	2-3	BT/Pri_Clock to Slot0	Closed (1-2) – Enable slot 1 Clock to BT clock through op amp
J7B1	1-X	Power to BT regulator	Closed (1-2) - Enable 3.3V AUX power to BT regulator

For additional information please refer to the *Upham IV User Guide* and *Upham IV Schematics*.

A.7 Docking Connector Card (Saddlestring II) (Not Included)

Saddlestring II is a docking station connector card. Saddlestring II plugs into the development board by means of a docking connector. This add-in card has been redesigned to add support for the iAMPS solution supported on the Pillar Rock development board. Also Display Port and HDMI features are added from Saddlestring. It also retains all the supported features of the original Saddlestring design

Figure 20. Saddlestring II Docking Connector

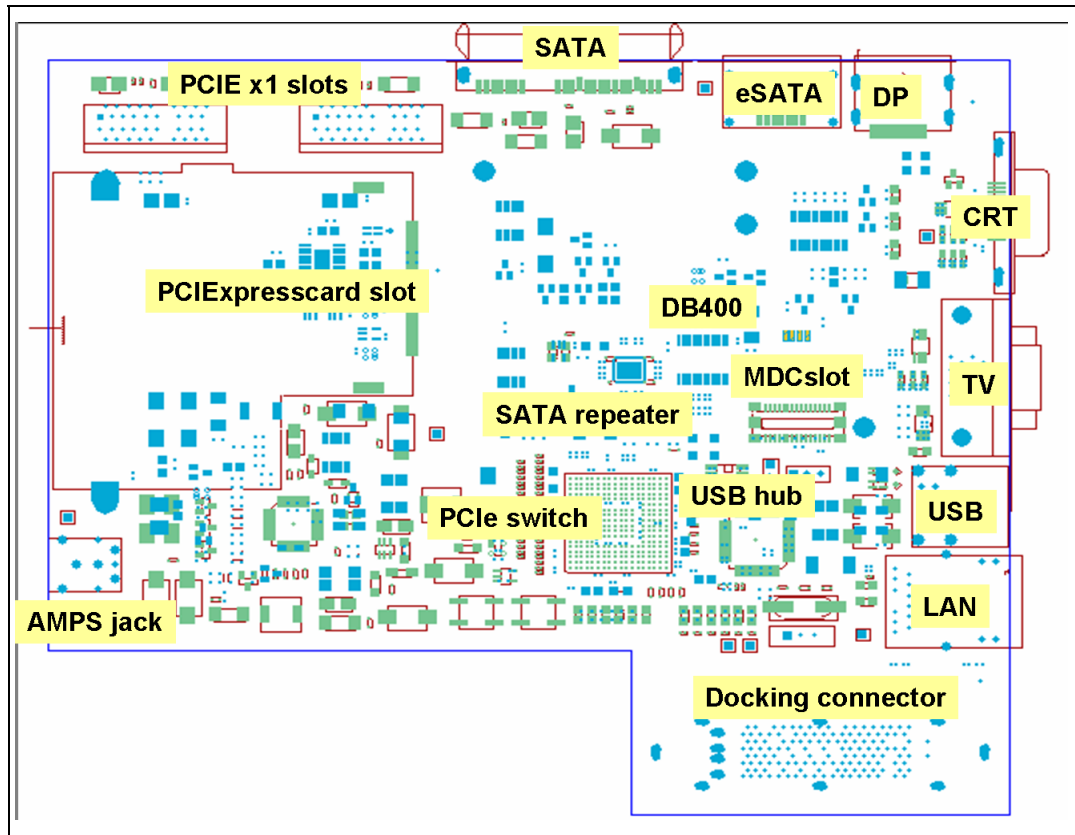

Please refer to the *Saddlestring II Fab 1 Users Guide* for details on using each of these interfaces and reworks that may be required on the board.

The below table describes the reworks required for routing Display Port to the Docking station

Note: All rework should use lead-free solder in order to keep the board RoHS compliant.

Table 25. Board Rework to Support Display Port on Saddlestring

STUFF	UNSTUFF	BOM	Description
	C6C11	CAPC,X5R,0402,10V,10%,0.1uF. IPN : A36096-043	To disconnect TX11# from MCH to PEG
	C6C13	CAPC,X5R,0402,10V,10%,0.1uF. IPN : A36096-044	To disconnect TX11 from MCH to PEG
	C6C15	CAPC,X5R,0402,10V,10%,0.1uF. IPN : A36096-045	To disconnect TX10# from MCH to PEG
	C6C18	CAPC,X5R,0402,10V,10%,0.1uF. IPN : A36096-046	To disconnect TX10 from MCH to PEG
	C6D2	CAPC,X5R,0402,10V,10%,0.1uF. IPN : A36096-047	To disconnect TX9# from MCH to PEG



STUFF	UNSTUFF	BOM	Description
	C6D3	CAPC,X5R,0402,10V,10%,0.1uF. IPN : A36096-048	To disconnect TX9 from MCH to PEG
	C6D7	CAPC,X5R,0402,10V,10%,0.1uF. IPN : A36096-049	To disconnect TX7# from MCH to PEG
	C6D9	CAPC,X5R,0402,10V,10%,0.1uF. IPN : A36096-050	To disconnect TX7 from MCH to PEG
C6C10		CAPC,X5R,0402,10V,10%,0.1uF. IPN : A36096-051	To route TX11 from Docking connector to MCH
C6C12		CAPC,X5R,0402,10V,10%,0.1uF. IPN : A36096-052	To route TX11# from Docking connector to MCH
C6D6		CAPC,X5R,0402,10V,10%,0.1uF. IPN : A36096-053	To route TX8 from Docking connector to MCH
C6D8		CAPC,X5R,0402,10V,10%,0.1uF. IPN : A36096-054	To route TX8# from Docking connector to MCH
C6C16		CAPC,X5R,0402,10V,10%,0.1uF. IPN : A36096-055	To route TX10 from Docking connector to MCH
C6C17		CAPC,X5R,0402,10V,10%,0.1uF. IPN : A36096-056	To route TX10# from Docking connector to MCH
C6D1		CAPC,X5R,0402,10V,10%,0.1uF. IPN : A36096-057	To route TX9 from Docking connector to MCH
C6D4		CAPC,X5R,0402,10V,10%,0.1uF. IPN : A36096-058	To route TX9# from Docking connector to MCH
R6R1		RESD,0402,5%,1/16W,0 IPN : A93549-001	These are the AUX signals of the Display Port. It connects to MCH on RX9 and RX9# respectively
R6R2		RESD,0402,5%,1/16W,0 IPN : A93549-002	
R6R3		RESD,0402,5%,1/16W,0 IPN : A93549-003	To connect the level translated Hot Plug Docking (HPD) to MCH

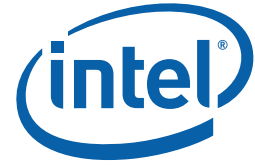

Appendix B Rework Instructions

B.1 Internal HDMI Enabling

Note: All rework should use lead-free solder in order to keep the board RoHS compliant.

Follow the instructions below to enable Internal HDMI

1. Unstuff R5T10.

Figure 21. iHDMI Rework Instruction 1

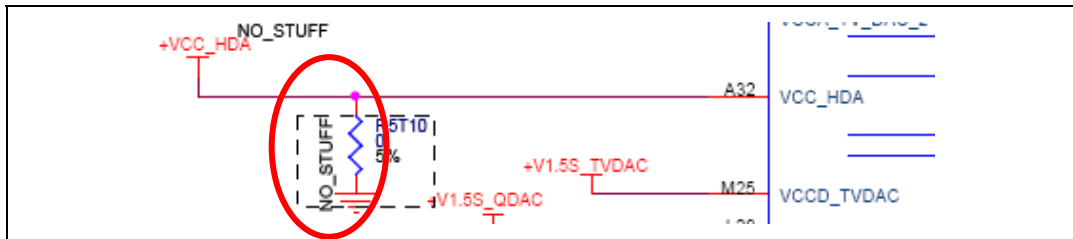

2. Stuff the following resistors R7V4,R7V3,R7V9,R7V24 and R7F7 . All of the resistors should be of value 33 Ω.

Figure 22. iHDMI Rework Instruction 2

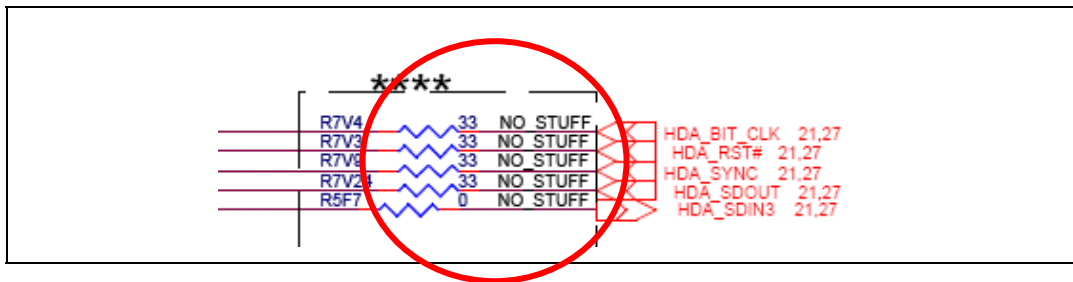

B.2 Enabling the Integrated Trusted Platform Module (iTPM)

1. Populate a 2.2 kΩ resistor at R1T7 on the bottom of the board. A 1x2 jumper can be connected to this topology to easily enable and disable the integrated TPM. When the Integrated TPM is disabled, TPM commands to be sent down to the LPC header on the platform.
2. Add 1 kΩ to R7U9
3. Connect the 2 pin Jumper on J7H2.

Note: All rework should use lead-free solder in order to keep the board RoHS compliant.



B.3 Enabling External HDMI

If using an external HDMI codec, depending on the configuration:

Stuff R7G3, R7G2, R7V8, R7G11 and one of R9E13 or R9E10 depending on the add-in card and

NoStuff R7V24,R7V8,R7V3,R7V4,R5F7,R9E14,R9E12 ,R9E8

Note: All rework should use lead-free solder in order to keep the board RoHS compliant.

B.4 Support for Upham 4

Stuff R8B5 and R7C1

Note: All rework should use lead-free solder in order to keep the board RoHS compliant.

B.5 Low Voltage High-Definition (HD) Audio Rework

Note: All rework should use lead-free solder in order to keep the board RoHS compliant.

Follow the steps below to enable the Low Voltage HD Audio:

1. Unstuff R8E7 and stuff R8E8
2. Unstuff R7H3 and stuff R7H2

Figure 23. Low Voltage HD Audio Rework (Always Rail)

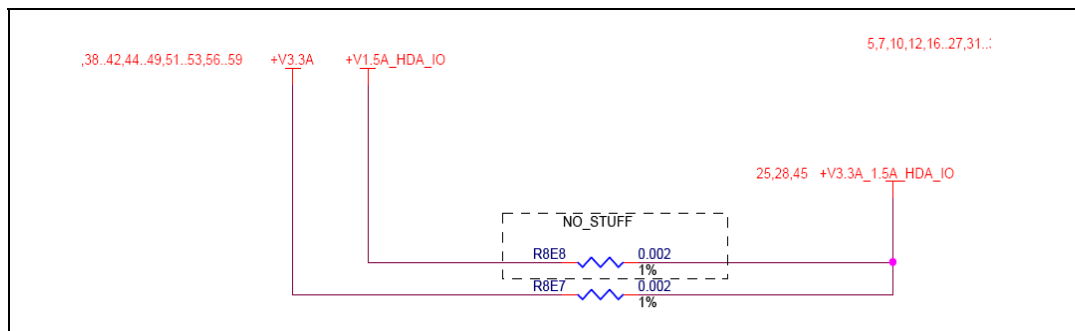
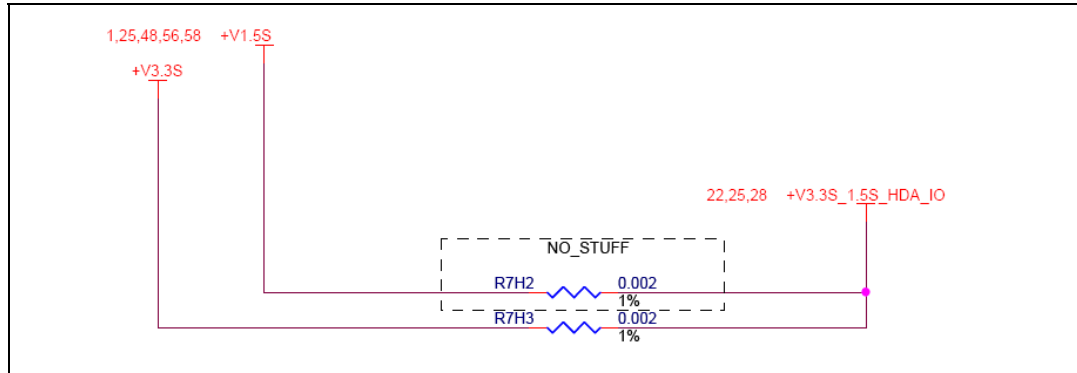



Figure 24. Low Voltage HD Audio Rework (Sus Rail)



§



Appendix C Programming system BIOS using a flash programming device

The BIOS for the Pillar Rock development board is in two non-removable flash devices. The flash can be programmed using a bootable DOS device, or through a special BIOS programming device that connects to header J8D2 on the board. One such programming device is the Dediprog SF100 available from the manufacturer at www.dediprog.com.

The Pillar Rock development board required the use of a 2 partition SPI image for SPI-0 and SPI-1 respectively. The descriptors are stored on SPI-0 while the BIOS is on SPI-1.

To program the flash using a flash programming device:

1. Setup the hardware and software of the flash programming device on a host system according to the manufacturers instructions.
2. Obtain the latest BIOS image (separated into two .bin files). Store the image files on the host system.
3. Disconnect the power supply of the development board
4. Connect the programming device to the development board at J8D2
5. Set jumpers J9C1 and J9D1 at 1-2
6. Set jumper J8C1 at 1-2 for SPI-0. Erase the existing image and flash the .bin image corresponding to SPI-0
7. Set the jumper J8C1 at 2-3 for SPI-1. Erase the existing image and flash the .bin image corresponding to SPI-1
8. Once the programming is successful on both the SPI, set J8C1, J9C1 and J9D1 to 1-X
9. Remove the flash programmer connector from J8D2
10. Set the jumper J8H1 at 1-X for booting from the SPI

§



Appendix D CPU Thermal Solution (Heatsink) Installation

It is necessary for the Intel® Core™ 2 Duo processor to have a thermal solution attached to it in order to keep it within its operating temperature.

Caution: An ESD wrist strap must be used when handling the board and installing the heatsink/fan assembly.

A heatsink is included in the kit. To install the heatsink:

1. If not done already, attach the CPU fan to the top of the CPU heatsink with 4 screws. The label on the fan should face down.
2. Remove the heatsink from its package and separate the fan heatsink portion from the heatsink backplate. (See the figure below)

Figure 25. Step 2 - Heatsink and Backplate

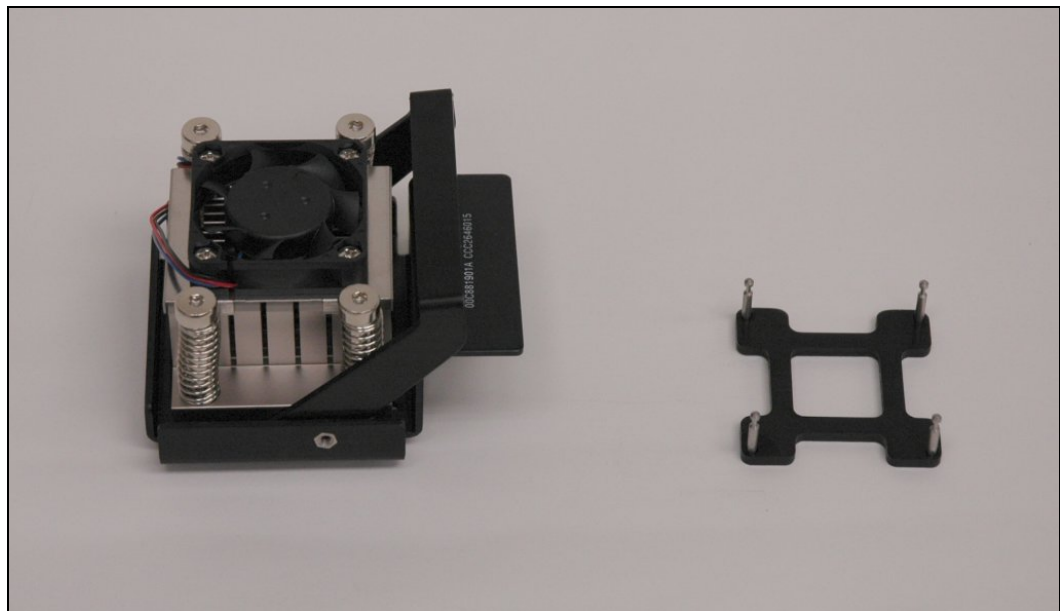

3. Examine the base of the heatsink, where contact with the processor die is made. This surface should be clean of all materials and greases. Wipe the bottom surface clean with isopropyl alcohol.
4. Place the backplate on the underside of the development board so that the pins protrude through the holes in the development board around the processor. (See the figure below)

Figure 26. Step 4 - Backplate Pins

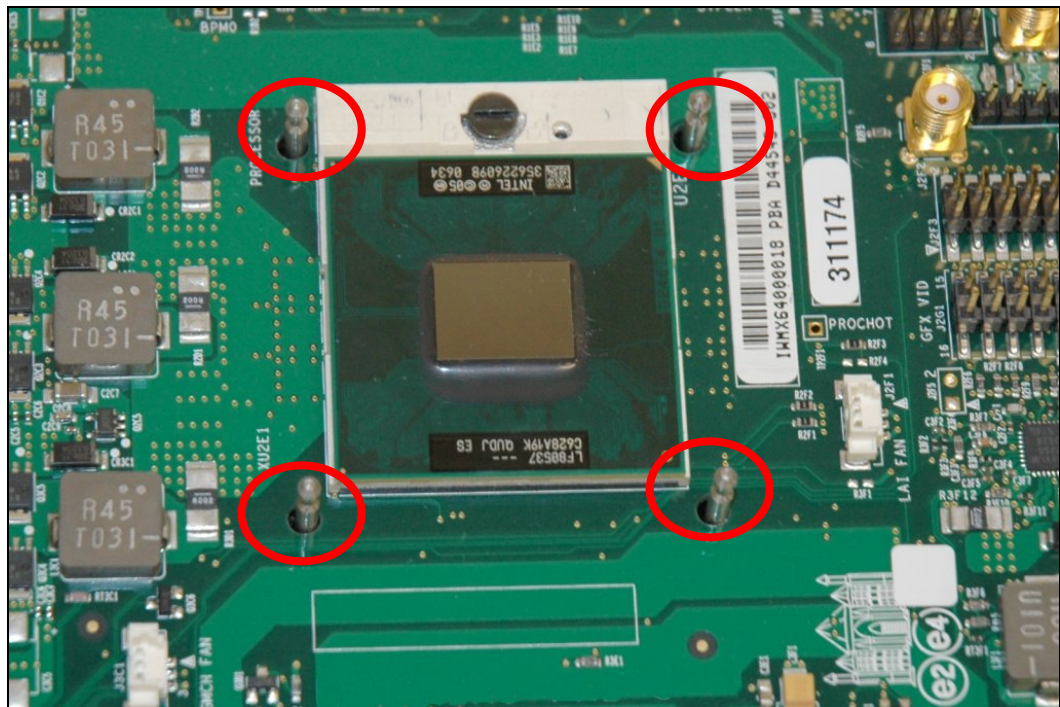



5. Clean the die of the processor with isopropyl alcohol before the heatsink is attached to the processor. This ensures that the surface of the die is clean.
6. Remove the tube of thermal grease from the package and use it to coat the exposed die of the CPU with the thermal grease. (See the figure below)

Figure 27. Step 6 - Applying the Thermal Grease

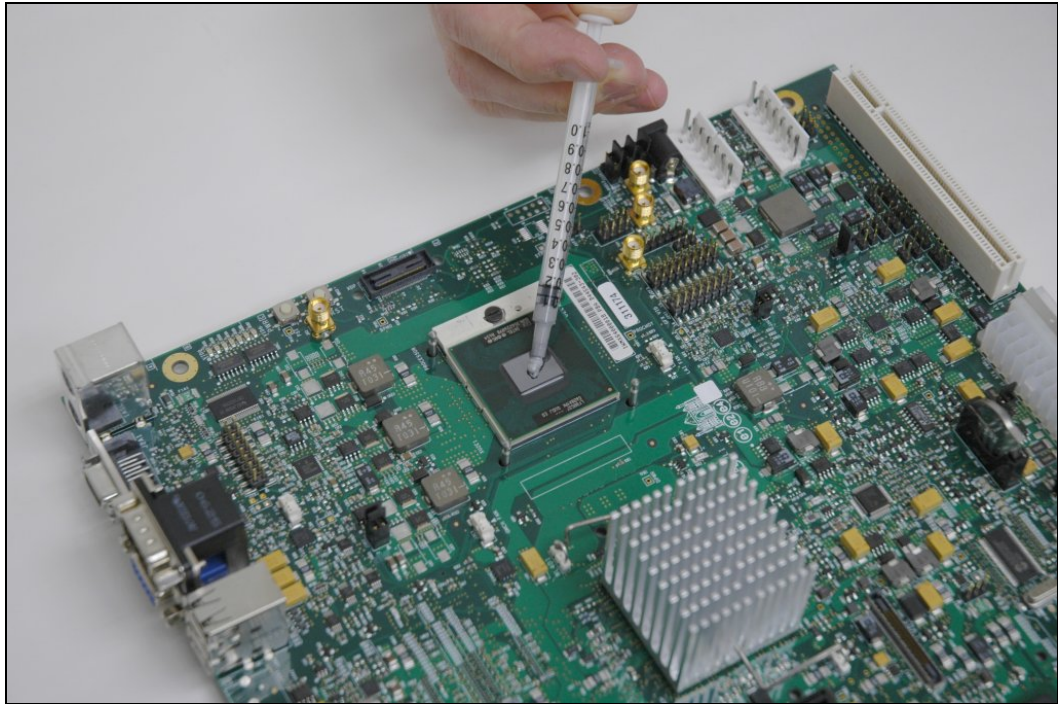



7. Pick up the heatsink and squeeze the activation arm until it comes in contact with the base plate that is attached to the heatsink base. This will cause the springs on the heatsink attachment mechanism to compress. (See the figure below)

Figure 28. Step 7 - Squeezing Activation Arm

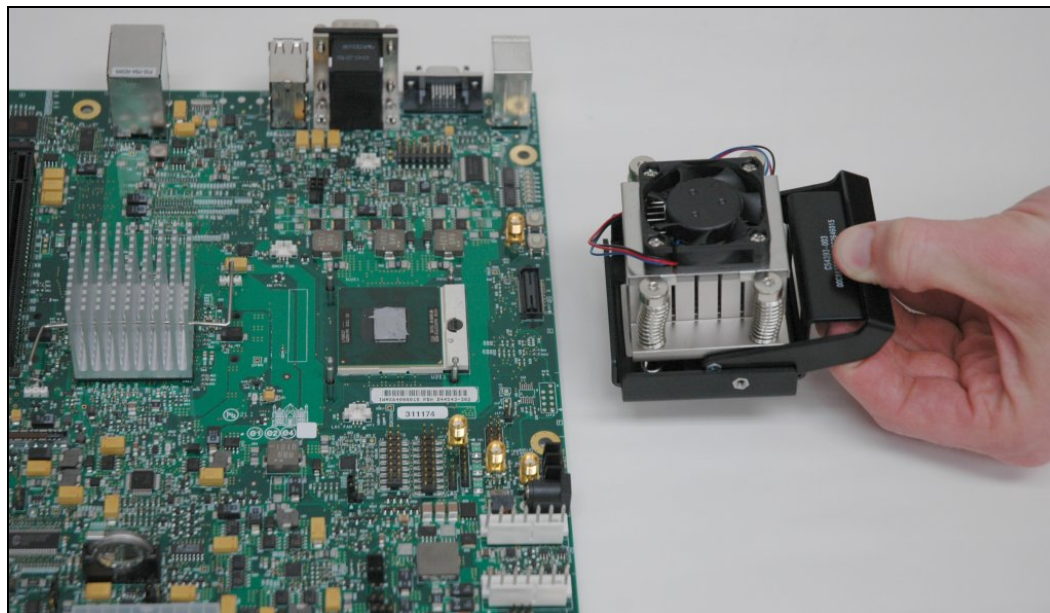



8. While keeping the activation arm compressed, place the heatsink over the pins of the heatsink backplate. Lower the heatsink until the lugs have inserted into the base of the heatsink. Slide the heatsink over the lugs on the backplate pins so that the base is directly over the processor die and the pins on the backplate have travelled the entire length of the channel in the heatsink base. Slowly let go of the activation arm until the base of the heatsink makes contact with the processor die. The heatsink base should be flat on top of the processor die.

Figure 29. Step 8 - Installing the Heatsink

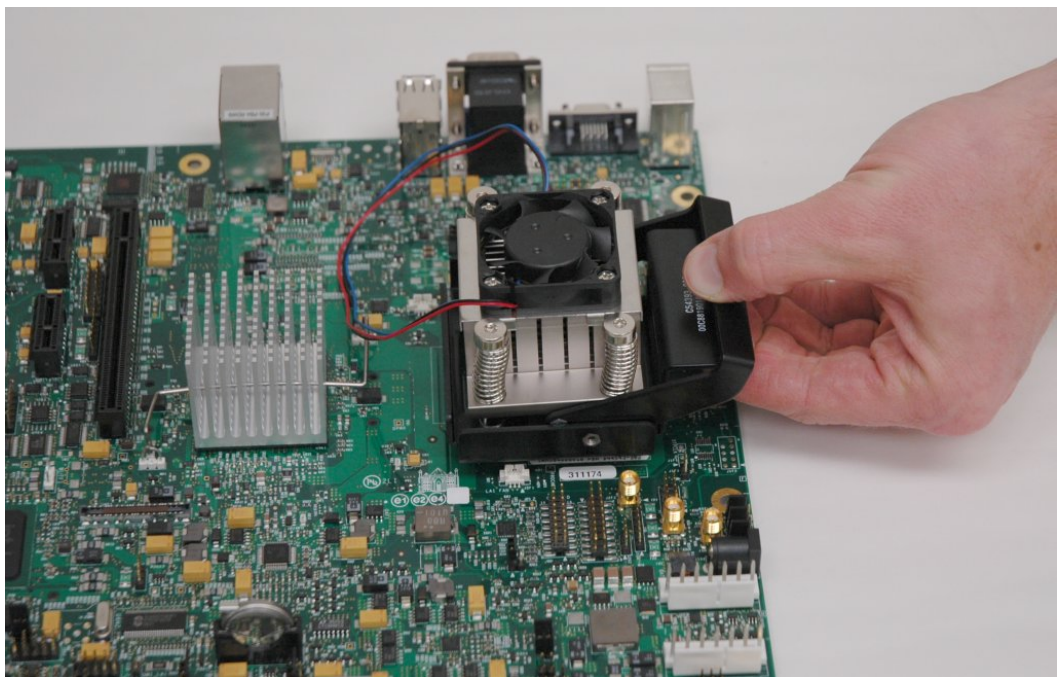



9. Plug the fan connector for the heatsink onto the CPU fan header (J2B3) on the motherboard. (See the figure below) The CPU fan header (J2B3) is a 3-pin connector with the words CPU Fan printed beside it.

Figure 30. Step 9 - Plugging in the Fan

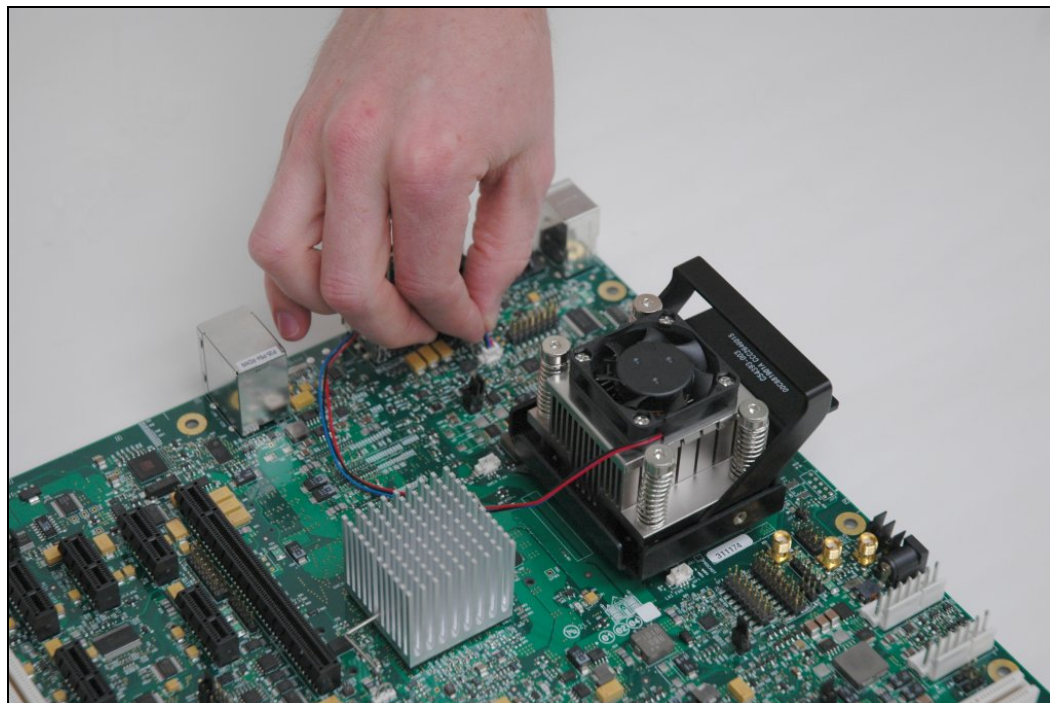



10. Once the thermal solution is in-place, the development kit is ready to use.

Figure 31. Step 10 - Completed Assembly

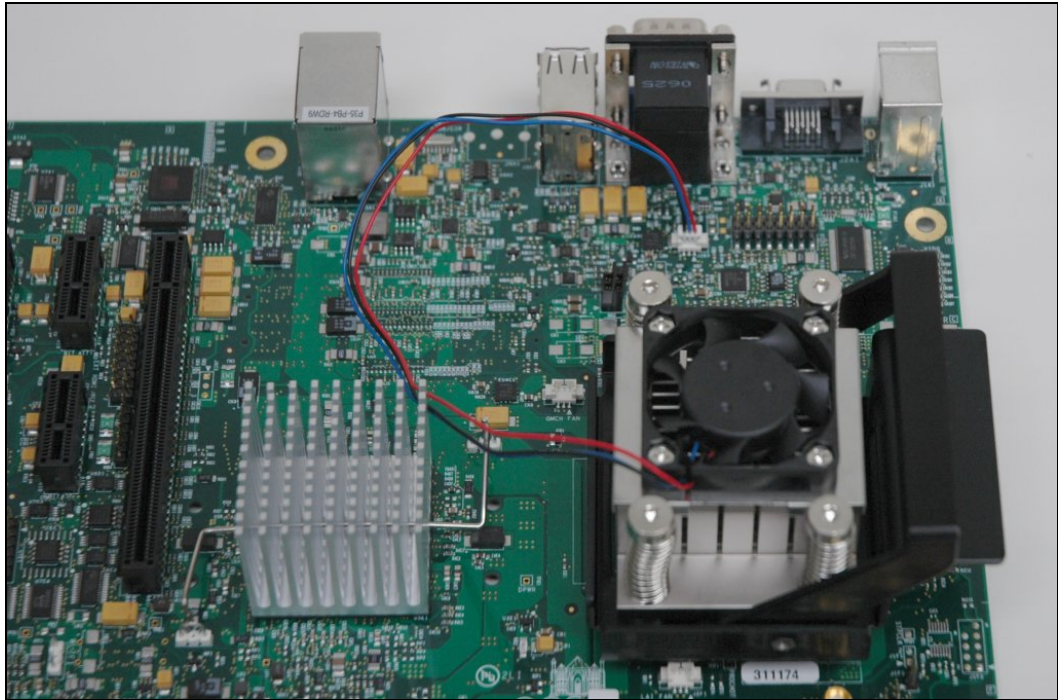

§