

Intel[®] Core[™]2 Extreme Processor QX6800^Δ and Intel[®] Core[™]2 Extreme Processor QX9770^Δ

Thermal and Mechanical Design Guidelines

— *For the Intel[®] Core[™]2 Extreme Processor QX6800^Δ B3 Stepping and the Intel[®] Core[™]2 Extreme Processor QX9770^Δ C0 Stepping*

March 2008



THIS DOCUMENT AND RELATED MATERIALS AND INFORMATION ARE PROVIDED "AS IS" WITH NO WARRANTIES, EXPRESS OR IMPLIED, INCLUDING BUT NOT LIMITED TO ANY IMPLIED WARRANTY OF MERCHANTABILITY, FITNESS FOR A PARTICULAR PURPOSE, NON-INFRINGEMENT OF INTELLECTUAL PROPERTY RIGHTS, OR ANY WARRANTY OTHERWISE ARISING OUT OF ANY PROPOSAL, SPECIFICATION, OR SAMPLE. INTEL ASSUMES NO RESPONSIBILITY FOR ANY ERRORS CONTAINED IN THIS DOCUMENT AND HAS NO LIABILITIES OR OBLIGATIONS FOR ANY DAMAGES ARISING FROM OR IN CONNECTION WITH THE USE OF THIS DOCUMENT. Intel products are not intended for use in medical, life saving, life sustaining, critical control or safety systems, or in nuclear facility applications.

Intel Corporation may have patents or pending patent applications, trademarks, copyrights, or other intellectual property rights that relate to the presented subject matter. The furnishing of documents and other materials and information does not provide any license, express or implied, by estoppel or otherwise, to any such patents, trademarks, copyrights, or other intellectual property rights.

Intel may make changes to specifications and product descriptions at any time, without notice. Intel accepts no duty to update specifications or product descriptions with information. Designers must not rely on the absence or characteristics of any features or instructions marked "reserved" or "undefined." Intel reserves these for future definition and shall have no responsibility whatsoever for conflicts or incompatibilities arising from future changes to them.

The hardware vendor remains solely responsible for the design, sale and functionality of its product, including any liability arising from product infringement or product warranty. Intel provides this information for customer's convenience only. Use at your own risk. Intel accepts no liability for results if customer chooses at its discretion to implement these methods within its business operations. Intel makes no representations or warranties regarding the accuracy or completeness of the information provided.

Copies of documents which have an order number and are referenced in this document, or other Intel literature, may be obtained by calling 1-800-548-4725, or by visiting <http://www.intel.com>.

The Intel® Core™2 Extreme Processor QX6800 and Intel® Core™2 Extreme Processor QX9770 may contain design defects or errors known as errata, which may cause the product to deviate from published specifications. Current characterized errata are available on request.

Not all specified units of this processor support Thermal Monitor 2 (TM2). See the Processor Spec Finder at <http://processorfinder.intel.com> or contact your Intel representative for more information.

⁴Intel processor numbers are not a measure of performance. Processor numbers differentiate features within each processor family, not across different processor families. Over time processor numbers will increment based on changes in clock, speed, cache, FSB, or other features, and increments are not intended to represent proportional or quantitative increases in any particular feature. Current roadmap processor number progression is not necessarily representative of future roadmaps. See www.intel.com/products/processor_number for details.

Intel, Pentium, Core, and the Intel logo are trademarks of Intel Corporation in the U.S. and other countries.

*Other names and brands may be claimed as the property of others.

Copyright © 2007–2008 Intel Corporation



Contents

1	Introduction	9
1.1	Document Goals and Scope	9
1.1.1	Importance of Thermal Management	9
1.1.2	Document Goals	9
1.1.3	Document Scope	10
1.2	References	11
1.3	Definition of Terms	11
2	Processor Thermal/Mechanical Information	13
2.1	Mechanical Requirements	13
2.1.1	Processor Package	13
2.1.2	Heatsink Attach	15
2.1.2.1	General Guidelines	15
2.1.2.2	The Pump Assembly Clip Load Requirement	15
2.1.2.3	Additional Guidelines	16
2.2	Thermal Requirements	16
2.2.1	Processor Case Temperature	16
2.2.2	Thermal Profile	17
2.2.3	T _{CONTROL}	18
2.3	Heatsink Design Considerations	19
2.3.1	Heatsink Size	20
2.3.2	Package IHS Flatness	20
2.3.3	Thermal Interface Material	21
2.4	System Thermal Solution Considerations	21
2.4.1	Chassis Thermal Design Capabilities	21
2.4.2	Improving Chassis Thermal Performance	21
2.4.3	Summary	22
2.5	System Integration Considerations	22
3	Thermal Metrology	23
3.1	Characterizing Cooling Performance Requirements	23
3.1.1	Example	25
3.2	Processor Thermal Solution Performance Assessment	26
3.3	Local Ambient Temperature Measurement Guidelines	26
3.4	Processor Case Temperature Measurement Guidelines	29
4	Thermal Management Logic and Thermal Monitor Feature	31
4.1	Processor Power Dissipation	31
4.2	Thermal Monitor Implementation	31
4.2.1	PROCHOT# Signal	32
4.2.2	Thermal Control Circuit	32
4.2.3	Thermal Monitor 2	33
4.2.4	Operation and Configuration	34
4.2.5	On-Demand Mode	35
4.2.6	System Considerations	35
4.2.7	Operating System and Application Software Considerations	36



- 4.2.8 THERMTRIP# Signal..... 36
- 4.2.9 Cooling System Failure Warning 36
- 4.2.10 Digital Thermal Sensor 37
- 4.2.11 Platform Environmental Control Interface (PECI)..... 38
- 5 Intel Thermal/Mechanical Reference Design Information 39
 - 5.1 Validation Results for the ATX Reference Design 39
 - 5.1.1 Heatsink Performance 40
 - 5.1.2 Acoustics 40
 - 5.1.3 Altitude..... 41
 - 5.1.4 Reference Heatsink Thermal Validation 41
 - 5.1.5 Fan Motor Performance 42
 - 5.1.6 Pump Motor Performance 43
 - 5.2 Environmental Reliability Testing 44
 - 5.2.1 Structural Reliability Testing 44
 - 5.2.1.1 Random Vibration Test Procedure..... 44
 - 5.2.1.2 Shock Test Procedure 45
 - 5.2.2 Power Cycling 46
 - 5.2.3 Reliability Testing 46
 - 5.2.3.1 Tubing Material Selection 48
 - 5.2.3.2 Reservoir Sizing 48
 - 5.2.3.3 Reliability Test Results..... 50
 - 5.2.4 Recommended BIOS/CPU/Memory Test Procedures 51
 - 5.3 Material and Recycling Requirements 52
 - 5.4 Safety Requirements 52
 - 5.5 Geometric Envelope for Intel Reference ATX Thermal Mechanical Design 52
 - 5.6 Reference Attach Mechanism..... 54
 - 5.7 Socket and Voltage Regulation Cooling Strategy 55
- 6 Intel® Quiet System Technology (Intel® QST) 57
 - 6.1 Intel® Quiet System Technology Algorithm..... 57
 - 6.1.1 Output Weighting Matrix 58
 - 6.1.2 Proportional-Integral-Derivative (PID) 58
 - 6.2 Board and System Implementation of Intel® Quiet System Technology 60
 - 6.3 Intel® QST Configuration & Tuning..... 62
 - 6.4 Fan Hub Thermistor and Intel® QST 62
- Appendix A LGA775 Socket Heatsink Loading 63
 - A.1 LGA775 Socket Heatsink Considerations 63
 - A.2 Metric for Heatsink Preload for ATX/uATX Designs Non-Compliant with Intel® Reference Design 64
 - A.2.1 Heatsink Preload Requirement Limitations..... 64
 - A.2.2 Motherboard Deflection Metric Definition..... 64
 - A.2.3 Board Deflection Limits 66
 - A.2.4 Board Deflection Metric Implementation Example..... 66
 - A.2.5 Additional Considerations 67
 - A.2.5.1 Motherboard Stiffening Considerations 68
 - A.3 Heatsink Selection Guidelines..... 68
- Appendix B Heatsink Clip Load Metrology 69
 - B.1 Overview 69
 - B.2 Test Preparation..... 69



	B.2.1	Heatsink Preparation.....	69
	B.2.2	Typical Test Equipment	72
B.3		Test Procedure Examples.....	72
	B.3.1	Time-Zero, Room Temperature Preload Measurement.....	73
	B.3.2	Preload Degradation under Bake Conditions	73
Appendix C		Thermal Interface Management.....	75
	C.1	Bond Line Management	75
	C.2	Interface Material Area	75
	C.3	Interface Material Performance.....	75
Appendix D		Case Temperature Reference Metrology.....	77
	D.1	Objective and Scope	77
	D.2	Supporting Test Equipment.....	78
	D.3	Thermal Calibration and Controls.....	79
	D.4	IHS Groove	79
	D.5	Thermocouple Attach Procedure	82
	D.5.1	Thermocouple Conditioning and Preparation	82
	D.5.2	Thermocouple Attachment to the IHS.....	83
	D.5.3	Solder Process	88
	D.5.4	Cleaning and Completion of Thermocouple Installation.....	91
	D.6	Thermocouple Wire Management	95
Appendix E		Legacy Fan Speed Control	97
	E.1	Thermal Solution Design	97
	E.1.1	Determine Thermistor Set Points	97
	E.1.2	Minimum Fan Speed Set Point.....	98
	E.2	Board and System Implementation	99
	E.2.1	Choosing Fan Speed Control Settings	99
	E.2.1.1	Temperature to Begin Fan Acceleration	100
	E.2.1.2	Minimum PWM Duty Cycle.....	102
	E.3	Combining Thermistor and Digital Thermal sensor Control.....	103
	E.4	Interaction of Thermal Profile and T _{CONTROL}	103
Appendix F		BTX System Thermal Considerations.....	109
Appendix G		Mechanical Drawings	113
Appendix H		Intel Enabled Reference Solution Information.....	123



Figures

Figure 1. Package IHS Load Areas	13
Figure 2. Processor Case Temperature Measurement Location	17
Figure 3. Example Thermal Profile	18
Figure 4. Processor Thermal Characterization Parameter Relationships.....	24
Figure 5. Locations for Measuring Local Ambient Temperature, Active Heatsink	27
Figure 6. Locations for Measuring Local Ambient Temperature, Liquid-Cooling Heat Exchanger.....	28
Figure 7. Locations for Measuring Local Ambient Temperature, Passive Heatsink	28
Figure 8. Concept for Clocks under Thermal Monitor Control.....	33
Figure 9. Thermal Monitor 2 Frequency and Voltage Ordering	34
Figure 10. T _{CONTROL} for Digital Thermometer	37
Figure 11. Random Vibration PSD.....	44
Figure 12. Shock Acceleration Curve.....	45
Figure 13. The Assembly Cumulative Mass Loss Data in Continuous Operation Test at 50 °C and 1450 RPM	49
Figure 14. Thermal Resistance Curve for Liquid Loss of Reservoir	49
Figure 15. Reservoir Location.....	50
Figure 16. Intel® ALCT Reference Design Major Components	53
Figure 17. Heat Exchanger Fan Combination Foot Print View	53
Figure 18. Structure to Motherboard Interface.....	54
Figure 19. Diagram of Location of Heat Exchanger VR and Socket Airflow Cooling Feature.....	55
Figure 20. CPU Maximum Current Draw for Heat Exchanger Fan Speed.....	56
Figure 21. Intel® Quiet System Technology Overview	58
Figure 22. PID Controller Fundamentals	59
Figure 23. Intel® Quiet System Technology Platform Requirements	60
Figure 24. Example Acoustic Fan Speed Control Implementation.....	61
Figure 25. Digital Thermal Sensor and Thermistor.....	62
Figure 26. Board Deflection Definition	65
Figure 27. Example: Defining Heatsink Preload Meeting Board Deflection Limit	67
Figure 28. Load Cell Installation in Machined Heatsink Base Pocket – Bottom View ...	70
Figure 29. Load Cell Installation in Machined Heatsink Base Pocket – Side View	71
Figure 30. Preload Test Configuration.....	71
Figure 31. Omega Thermocouple.....	79
Figure 32. 775-LAND LGA Package Reference Groove Drawing.....	80
Figure 33. IHS Groove on the 775-LAND LGA Package.....	81
Figure 34. IHS Groove Orientation Relative to the LGA775 Socket.....	81
Figure 35. Inspection of Insulation on Thermocouple.....	82
Figure 36. Bending the Tip of the Thermocouple	83
Figure 37. Securing Thermocouple Wires with Kapton* Tape Prior to Attach	83
Figure 38. Thermocouple Bead Placement.....	84
Figure 39. Position Bead on the Groove Step.....	85
Figure 40. Detailed Thermocouple Bead Placement	85
Figure 41. Third Tape Installation	86
Figure 42. Measuring Resistance between Thermocouple and IHS	86
Figure 43. Applying Flux to the Thermocouple Bead	87
Figure 44. Cutting Solder	87
Figure 45. Positioning Solder on IHS.....	88
Figure 46. Solder Station Setup	89
Figure 47. View Through Lens at Solder Station.....	90
Figure 48. Moving Solder back onto Thermocouple Bead.....	90



Figure 49. Removing Excess Solder	91
Figure 50. Thermocouple placed into groove	92
Figure 51. Removing Excess Solder	92
Figure 52. Filling Groove with Adhesive	93
Figure 53. Application of Accelerant	93
Figure 54. Removing Excess Adhesive from IHS	94
Figure 55. Finished Thermocouple Installation	94
Figure 56. Thermocouple Wire Management.....	95
Figure 57. Thermistor Set Points	98
Figure 58. Example Fan Speed Control Implementation	99
Figure 59. Fan Speed Control.....	100
Figure 60. Temperature Range = 5 °C	101
Figure 61. Temperature Range = 10 °C.....	102
Figure 62. Digital Thermal Sensor and Thermistor.....	103
Figure 63. FSC Definition Example.....	105
Figure 64. System Airflow Illustration with System Monitor Point Area Identified	110
Figure 65. Thermal sensor Location Illustration	111
Figure 66. ATX/μATX Motherboard Keep-out Footprint Definition and Height Restrictions for Enabling Components - Sheet 1	114
Figure 67. ATX/μATX Motherboard Keep-out Footprint Definition and Height Restrictions for Enabling Components - Sheet 2.....	115
Figure 68. ATX/μATX Motherboard Keep-out Footprint Definition and Height Restrictions for Enabling Components - Sheet 3.....	116
Figure 69. Balanced Technology Extended (BTX) Thermal Module Keep Out Volumetric – Sheet 1	117
Figure 70. Balanced Technology Extended (BTX) Thermal Module Keep Out Volumetric – Sheet 2	118
Figure 71. Balanced Technology Extended (BTX) Thermal Module Keep Out Volumetric – Sheet 3	119
Figure 72. Balanced Technology Extended (BTX) Thermal Module Keep Out Volumetric – Sheet 4	120
Figure 73. Balanced Technology Extended (BTX) Thermal Module Keep Out Volumetric – Sheet 5	121
Figure 74. Intel Advanced Liquid Cooling Technology Assembly.....	122

Tables

Table 1. Heatsink Inlet Temperature of Intel Reference Thermal Solutions.....	21
Table 2. Intel Liquid Cooled Reference Design Performance (ALCT).....	40
Table 3. Acoustic Results.....	40
Table 4. Fan Electrical Performance Requirements	42
Table 5. Pump Electrical Performance Requirements.....	43
Table 6. The Reliability Test Matrix	47
Table 7. The Weekly Loss Rate of Different Tubing Materials.....	48
Table 8. Reliability Test Results	51
Table 9. Maximum Estimated Processor Current Capability at 35 °C External Ambient.....	56
Table 10. Board Deflection Configuration Definitions	65
Table 11. Typical Test Equipment	72
Table 12. FSC Definitions	104
Table 13. ATX FSC Settings	106
Table 14. BTX Fan Speed Control Settings	106
Table 15. Intel Representative Contact for Licensing Information	123
Table 16. Intel Reference Component ATX Thermal Solution Providers	123



Revision History

Revision Number	Description	Revision Date
-001	<ul style="list-style-type: none">Initial release	April 2007
-002	<ul style="list-style-type: none">Added Intel® Core™2 Extreme processor QX9770 C0 SteppingEdits throughout	March 2008

§



1 Introduction

1.1 Document Goals and Scope

1.1.1 Importance of Thermal Management

The objective of thermal management is to ensure that the temperatures of all components in a system are maintained within their functional temperature range. Within this temperature range, a component is expected to meet its specified performance. Operation outside the functional temperature range can degrade system performance, cause logic errors or cause component and/or system damage. Temperatures exceeding the maximum operating limit of a component may result in irreversible changes in the operating characteristics of this component.

In a system environment, the processor temperature is a function of both system and component thermal characteristics. The system level thermal constraints consist of the local ambient air temperature and airflow over the processor as well as the physical constraints at and above the processor. The processor temperature depends in particular on the component power dissipation, the processor package thermal characteristics, and the processor thermal solution.

All of these parameters are affected by the continued push of technology to increase processor performance levels and packaging density (more transistors). As operating frequencies increase and packaging size decreases, the power density increases while the thermal solution space and airflow typically become more constrained or remains the same within the system. The result is an increased importance on system design to ensure that thermal design requirements are met for each component, including the processor, in the system.

1.1.2 Document Goals

Depending on the type of system and the chassis characteristics, new system and component designs may be required to provide adequate cooling for the processor. The goal of this document is to provide an understanding of these thermal characteristics and discuss guidelines for meeting the thermal requirements imposed on single processor systems using the Intel® Core™2 Extreme processor QX6800 B3 Stepping and Intel® Core™2 Extreme processor QX9770 C0 Stepping.

The concepts given in this document are applicable to any system form factor. Specific examples used will be the Intel enabled reference solution for ATX/uATX systems. See the applicable BTX form factor reference documents to design a thermal solution for that form factor.



1.1.3 Document Scope

This design guide supports the following processor:

- Intel® Core™2 Extreme processor QX6800 B3 Stepping
- Intel® Core™2 Extreme processor QX9770 C0 Stepping

In this document when a reference is made to “the processor” it is intended that this includes all the processors supported by this document. If needed for clarity, the specific processor will be listed.

In this document, when a reference is made to “the datasheet”, the reader should refer to the *Intel® Core™2 Extreme Processor QX9000 Series and Intel® Core™2 Quad Processor Q9000 Series Datasheet* and *Intel® Core™2 Extreme Quad-Core Processor QX6000^A Sequence and Intel® Core™2 Quad Processor Q6000^A Sequence Datasheet*, as appropriate. If needed for clarity the specific processor datasheet will be referenced.

Chapter 2 of this document discusses package thermal mechanical requirements to design a thermal solution for the processor in the context of personal computer applications. Chapter 3 discusses the thermal solution considerations and metrology recommendations to validate a processor thermal solution.

Chapter 4 addresses the benefits of the processor’s integrated thermal management logic for thermal design.

Chapter 5 gives information on the Intel reference thermal solution called ALCT (Intel Advanced Liquid Cooling Technology) for the processor. Chapter 6 discusses the implementation of Intel® Quiet System Technology.

The physical dimensions and thermal specifications of the processor that are used in this document are for illustration only. Refer to the datasheet for the product dimensions, thermal power dissipation and maximum case temperature. In case of conflict, the data in the datasheet supersedes any data in this document.



1.2 References

Material and concepts available in the following documents may be beneficial when reading this document.

Document	Location
Intel® Core™2 Extreme Processor QX9000 Series and Intel® Core™2 Quad Processor Q9000 Series Datasheet	http://www.intel.com/design/processor/datashts/318726.htm
Intel® Core™2 Extreme Quad-Core Processor QX6000 ⁴ Sequence and Intel® Core™2 Quad Processor Q6000 ⁴ Sequence Datasheet	http://developer.intel.com/design/processor/datashts/315592.htm
LGA775 Socket Mechanical Design Guide	http://intel.com/design/Pentium4/guides/302666.htm
Fan Specification for 4-wire PWM Controlled Fans	http://www.formfactors.org/
ATX Thermal Design Suggestions	http://www.formfactors.org/
microATX Thermal Design Suggestions	http://www.formfactors.org/
Balanced Technology Extended (BTX) System Design Guide	http://www.formfactors.org/

1.3 Definition of Terms

Term	Description
T_A	The measured ambient temperature locally surrounding the processor. The ambient temperature should be measured just upstream of a passive heatsink or at the fan inlet for an active heatsink.
T_C	The case temperature of the processor, measured at the geometric center of the topside of the IHS.
T_E	The ambient air temperature external to a system chassis. This temperature is usually measured at the chassis air inlets.
T_S	Heatsink temperature measured on the underside of the heatsink base, at a location corresponding to T_C .
T_{C-MAX}	The maximum case temperature as specified in a component specification.
T_{LIQUID}	Working fluid temperature as it leaves the pump (or enters the heat exchanger).
Ψ_{CA}	Case-to-ambient thermal characterization parameter (psi). A measure of thermal solution performance using total package power. Defined as $(T_C - T_A) / \text{Total Package Power}$. Note: Heat source must be specified for Ψ measurements.
Ψ_{CS}	Case-to-sink thermal characterization parameter. A measure of thermal interface material performance using total package power. Defined as $(T_C - T_S) / \text{Total Package Power}$. Note: Heat source must be specified for Ψ measurements.
Ψ_{SA}	Sink-to-ambient thermal characterization parameter. A measure of heatsink thermal performance using total package power. Defined as $(T_S - T_A) / \text{Total Package Power}$. Note: Heat source must be specified for Ψ measurements.



Term	Description
TIM	Thermal Interface Material: The thermally conductive compound between the heatsink and the processor case. This material fills the air gaps and voids, and enhances the transfer of the heat from the processor case to the heatsink.
P_{MAX}	The maximum power dissipated by a semiconductor component.
TDP	Thermal Design Power: a power dissipation target based on worst-case applications. Thermal solutions should be designed to dissipate the thermal design power.
IHS	Integrated Heat Spreader: a thermally conductive lid integrated into a processor package to improve heat transfer to a thermal solution through heat spreading.
LGA775 Socket	The surface mount socket designed to accept the processors in the 775–Land LGA package.
ACPI	Advanced Configuration and Power Interface.
Bypass	Bypass is the area between a passive heatsink and any object that can act to form a duct. For this example, it can be expressed as a dimension away from the outside dimension of the fins to the nearest surface.
Thermal Monitor	A feature on the processor that attempts to keep the processor die temperature within factory specifications.
TCC	Thermal Control Circuit: Thermal Monitor uses the TCC to reduce die temperature by lowering effective processor frequency when the die temperature has exceeded its operating limits.
DTS	Digital Thermal Sensor: Processor die sensor temperature defined as an offset from the onset of PROCHOT#.
T_{DIODE}	Temperature reported from the on-die thermal diode.
FSC	Fan Speed Control: Thermal solution that includes a variable fan speed which is driven by a PWM signal and uses the digital thermal sensor as a reference to change the duty cycle of the PWM signal.
$T_{CONTROL_BASE}$	Constant from the processor datasheet that is added to the $T_{CONTROL_OFFSET}$ that results in the value for $T_{CONTROL}$.
$T_{CONTROL_OFFSET}$	Value read by the BIOS from a processor MSR and added to the $T_{CONTROL_BASE}$ that results in the value for $T_{CONTROL}$.
$T_{CONTROL}$	$T_{CONTROL}$ is the specification limit for use with the digital thermal sensor.
PWM	Pulse width modulation is a method of controlling a variable speed fan. The enabled 4 wire fans use the PWM duty cycle % from the fan speed controller to modulate the fan speed.
Health Monitor Component	Any standalone or integrated component that is capable of reading the processor temperature and providing the PWM signal to the 4 pin fan header.
BTX	Balanced Technology Extended
TMA	Thermal Module Assembly. The heatsink, fan and duct assembly for the BTX thermal solution



2 Processor Thermal/Mechanical Information

2.1 Mechanical Requirements

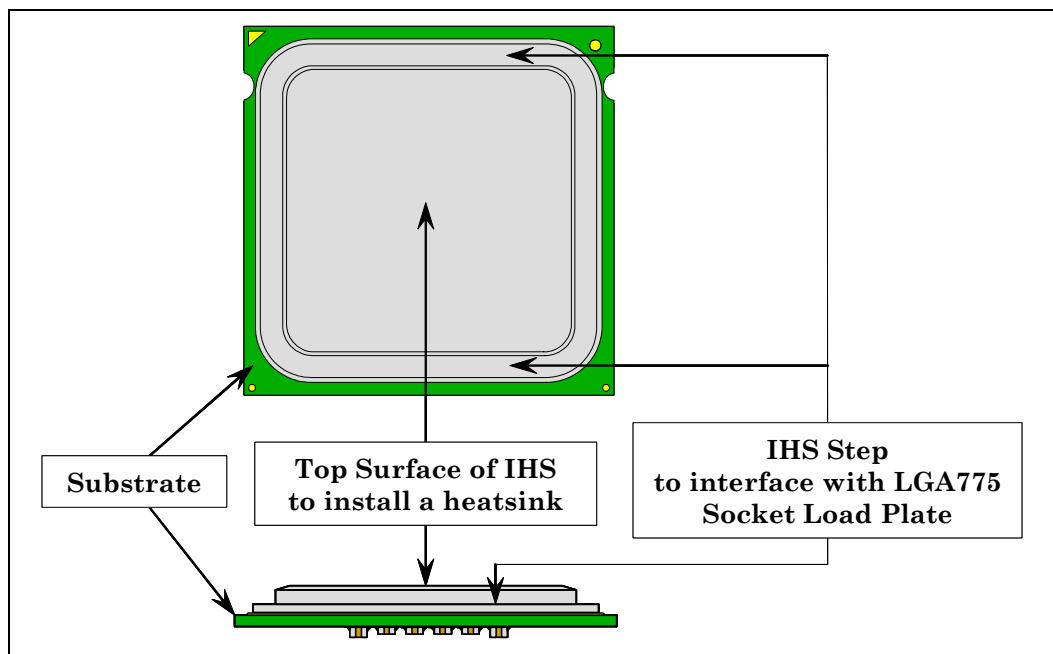
2.1.1 Processor Package

The processors covered in the document are packaged in a 775-Land LGA package that interfaces with the motherboard via a LGA775 socket. Refer to the datasheet for detailed mechanical specifications.

The processor connects to the motherboard through a land grid array (LGA) surface mount socket. The socket contains 775 contacts arrayed about a cavity in the center of the socket with solder balls for surface mounting to the motherboard. The socket is named LGA775 socket. A description of the socket can be found in the *LGA775 Socket Mechanical Design Guide*.

The package includes an integrated heat spreader (IHS) that is shown in Figure 1 for illustration only. Refer to the processor datasheet for further information. In case of conflict, the package dimensions in the processor datasheet supersedes dimensions provided in this document.

Figure 1. Package IHS Load Areas





The primary function of the IHS is to transfer the non-uniform heat distribution from the die to the top of the IHS, out of which the heat flux is more uniform and spread over a larger surface area (not the entire IHS area). This allows more efficient heat transfer out of the package to an attached cooling device. The top surface of the IHS is designed to be the interface for contacting a heatsink.

The IHS also features a step that interfaces with the LGA775 socket load plate, as described in *LGA775 Socket Mechanical Design Guide*. The load from the load plate is distributed across two sides of the package onto a step on each side of the IHS. It is then distributed by the package across all of the contacts. When correctly actuated, the top surface of the IHS is above the load plate allowing proper installation of a heatsink on the top surface of the IHS. After actuation of the socket load plate, the seating plane of the package is flush with the seating plane of the socket. Package movement during socket actuation is along the Z direction (perpendicular to substrate) only. Refer to the *LGA775 Socket Mechanical Design Guide* for further information about the LGA775 socket.

The processor package has mechanical load limits that are specified in the processor datasheet. The specified maximum static and dynamic load limits should not be exceeded during their respective stress conditions. These include heatsink installation, removal, mechanical stress testing, and standard shipping conditions.

- When a compressive static load is necessary to ensure thermal performance of the thermal interface material between the heatsink base and the IHS, it should not exceed the corresponding specification given in the processor datasheet.
- When a compressive static load is necessary to ensure mechanical performance, it should remain in the minimum/maximum range specified in the processor datasheet
- The heatsink mass can also generate additional dynamic compressive load to the package during a mechanical shock event. Amplification factors due to the impact force during shock must be taken into account in dynamic load calculations. The total combination of dynamic and static compressive load should not exceed the processor datasheet compressive dynamic load specification during a vertical shock. For example, with a 0.550 kg [1.2 lb] heatsink, an acceleration of 50G during an 11 ms trapezoidal shock with an amplification factor of 2 results in approximately a 539 N [117 lbf] dynamic load on the processor package. If a 178 N [40 lbf] static load is also applied on the heatsink for thermal performance of the thermal interface material the processor package could see up to a 717 N [156 lbf]. The calculation for the thermal solution of interest should be compared to the processor datasheet specification.

No portion of the substrate should be used as a load-bearing surface.

Finally, the processor datasheet provides package handling guidelines in terms of maximum recommended shear, tensile and torque loads for the processor IHS relative to a fixed substrate. These recommendations should be followed in particular for heatsink removal operations.



2.1.2 Heatsink Attach

2.1.2.1 General Guidelines

There are no features on the LGA775 socket to directly attach a heatsink: a mechanism must be designed to attach the heatsink directly to the motherboard. In addition to holding the heatsink in place on top of the IHS, this mechanism plays a significant role in the robustness of the system in which it is implemented, in particular:

- Ensuring thermal performance of the thermal interface material (TIM) applied between the IHS and the heatsink. TIMs based on phase change materials are very sensitive to applied pressure: the higher the pressure, the better the initial performance. TIMs, such as thermal greases, are not as sensitive to applied pressure. Designs should consider a possible decrease in applied pressure over time due to potential structural relaxation in retention components.
- Ensuring system electrical, thermal, and structural integrity under shock and vibration events. The mechanical requirements of the heatsink attach mechanism depend on the mass of the heatsink and the level of shock and vibration that the system must support. The overall structural design of the motherboard and the system have to be considered when designing the heatsink attach mechanism. Their design should provide a means for protecting LGA775 socket solder joints. The Intel ALCT reference design attach mechanism described in Section.5.6

Note: Package pull-out during mechanical shock and vibration is constrained by the LGA775 socket load plate (refer to the *LGA775 Socket Mechanical Design Guide* for further information).

2.1.2.2 The Pump Assembly Clip Load Requirement

The attach mechanism for the pump assembly developed to support the processor should create a static preload on the package between **18 lbf** and **70 lbf** throughout the life of the product for designs compliant with the Intel reference design assumptions:

- 72 mm x 72 mm mounting hole span (refer to Figure 66)

The minimum load is required to protect against fatigue failure of socket solder joint in temperature cycling.

It is important to take into account potential load degradation from creep over time when designing the pump assembly clip to the required minimum load. This means the initial preload at beginning of life of the product may be significantly higher than the minimum preload that must be met throughout the life of the product. For additional guidelines on mechanical design, in particular on designs departing from the reference design assumptions, refer to Appendix A.

For clip load metrology guidelines, refer to Appendix B.



2.1.2.3 Additional Guidelines

In addition to the general guidelines given above, the heatsink attach mechanism for the processor should be designed to the following guidelines:

- *Holds the heatsink in place under mechanical shock and vibration events and applies force to the heatsink base to maintain desired pressure on the thermal interface material.* Note that the load applied by the heatsink attach mechanism must comply with the package specifications described in the processor datasheet. One of the key design parameters is the height of the top surface of the processor IHS above the motherboard. The IHS height from the top of board is expected to vary from 7.517 mm to 8.167 mm. This data is provided for information only, and should be derived from:
 - The height of the socket seating plane above the motherboard after reflow, given in the *LGA775 Socket Mechanical Design Guide* with its tolerances
 - The height of the package, from the package seating plane to the top of the IHS, and accounting for its nominal variation and tolerances that are given in the corresponding processor datasheet.
- *Engages easily, and if possible, without the use of special tools.* In general, the heatsink is assumed to be installed after the motherboard has been installed into the chassis.
- *Minimizes contact with the motherboard surface during installation and actuation to avoid scratching the motherboard.*

2.2 Thermal Requirements

Refer to the datasheet for the processor thermal specifications. The majority of processor power is dissipated through the IHS. There are no additional components, e.g., BSRAMs, which generate heat on this package. The amount of power that can be dissipated as heat through the processor package substrate and into the socket is usually minimal.

The thermal limits for the processor are the Thermal Profile and T_{CONTROL} . The Thermal Profile defines the maximum case temperature as a function of power being dissipated. T_{CONTROL} is a specification used in conjunction with the temperature reported by the digital thermal sensor and a fan speed control method. Designing to these specifications allows optimization of thermal designs for processor performance and acoustic noise reduction.

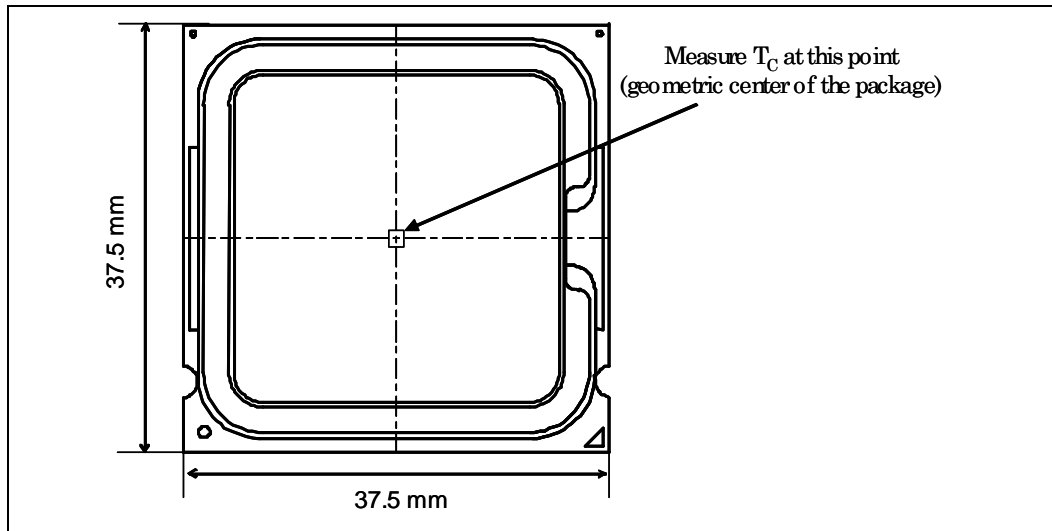
2.2.1 Processor Case Temperature

For the processor, the case temperature is defined as the temperature measured at the geometric center of the package on the surface of the IHS. For illustration, Figure 2 shows the measurement location for a 37.5 mm x 37.5 mm [1.474 in x 1.474 in] 775-Land LGA processor package with a 28.7 mm x 28.7 mm [1.13 in x 1.13 in] IHS top surface. Techniques for measuring the case temperature are detailed in Section 3.4.

Note: In case of conflict, the package dimensions in the processor datasheet supersedes dimensions provided in this document.



Figure 2. Processor Case Temperature Measurement Location



2.2.2 Thermal Profile

The Thermal Profile defines the maximum case temperature as a function of processor power dissipation. Refer to the datasheet for the further information.

While the thermal profile provides flexibility for ATX /BTX thermal design based on its intended target thermal environment, thermal solutions that are intended to function in a multitude of systems and environments need to be designed for the worst-case thermal environment. The majority of ATX /BTX platforms are targeted to function in an environment that will have up to a 35 °C ambient temperature external to the system.

For ATX platforms using the Intel® Core™2 Extreme processor QX6800 B3 stepping and QX9770 C0 stepping, an active liquid-cooled design should be designed to manage the heat exchanger inlet temperature of 35 °C + 3 °C = 38 °C (see Chapter 5).

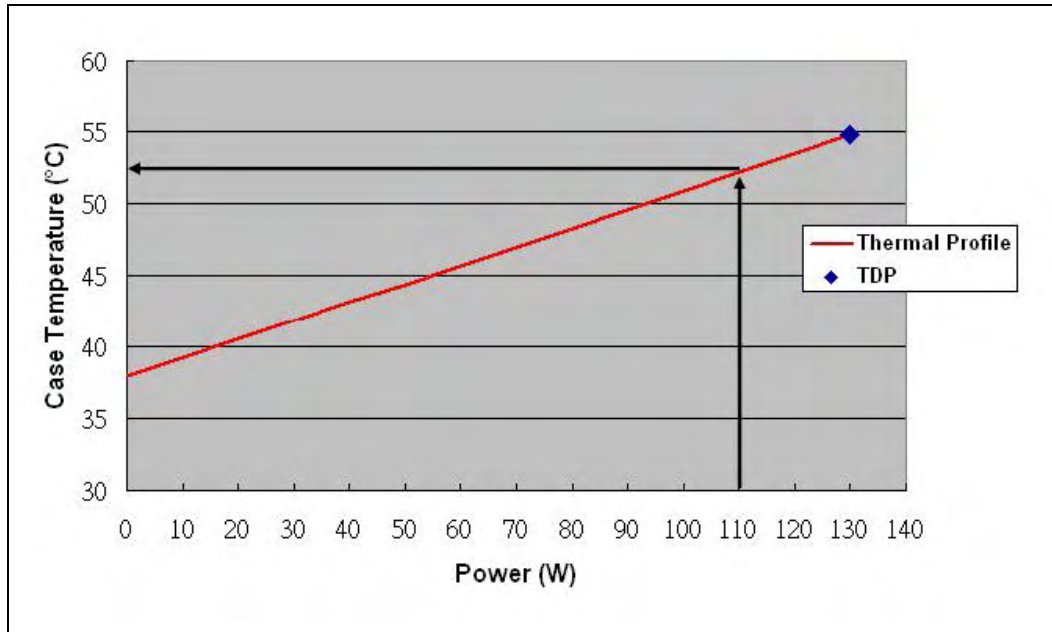
For BTX platforms, the similar BTX liquid cooling design should be designed to manage the heat exchanger inlet temperature of 35 °C + 0.5 °C = 35.5 °C.

The slope of the thermal profile was established to be the same as the Intel liquid cooling solution thermal solution performance. This performance is expressed as the slope on the thermal profile and can be thought of as the thermal resistance of the heatsink attached to the processor, Ψ_{CA} (Refer to Section 3.1). The intercept on the thermal profile assumes a maximum ambient operating condition that is consistent with the available chassis solutions.

The thermal profiles for the processor are defined such that a single thermal solution (e.g., ALCT reference design) can be used for Intel® Core™2 Extreme processor QX6800 B3 Stepping and QX9770 C0 Stepping processors. See Chapter 5 for a discussion of the ALCT reference design. To determine compliance to the thermal profile, a measurement of the actual processor power dissipation is required. The measured power is plotted on the Thermal Profile to determine the maximum case

temperature. Using the example in Figure 3 for a processor dissipating 110W the maximum case temperature is 52.2°C. See the datasheet for the thermal profile.

Figure 3. Example Thermal Profile



2.2.3 T_{CONTROL}

T_{CONTROL} defines the maximum operating temperature for the digital thermal sensor when the thermal solution fan speed is being controlled by the digital thermal sensor. The T_{CONTROL} parameter defines a very specific processor operating region where fan speed can be reduced. This allows the system integrator a method to reduce the acoustic noise of the processor cooling solution, while maintaining compliance to the processor thermal specification.

Note: The T_{CONTROL} value for the processor is relative to the Thermal Control Circuit (TCC) activation set point which will be seen as 0 via the digital thermometer. As a result the T_{CONTROL} value will always be a negative number. See Chapter 4 for the discussion the thermal management logic and features and Chapter 6 on *Intel® Quiet System Technology (Intel® QST)*.

The value of T_{CONTROL} is driven by a number of factors. One of the most significant of these is the processor idle power. As a result a processor with a high (closer to 0) T_{CONTROL} will dissipate more power than a part with lower value (farther from 0, e.g. more negative number) of T_{CONTROL} when running the same application.

The value of T_{CONTROL} is calculated such that regardless of the individual processor's T_{CONTROL} value the thermal solution should perform similarly. The higher power of some parts is offset by a higher value of T_{CONTROL} in such a way that they should behave similarly in the acoustic performance.



This is achieved in part by using the Ψ_{CA} vs. RPM and RPM vs. Acoustics (dBA) performance curves from the Intel enabled thermal solution. A thermal solution designed to meet the thermal profile would be expected to provide similar acoustic performance of different parts with potentially different $T_{CONTROL}$ values.

The value for $T_{CONTROL}$ is calculated by the system BIOS based on values read from a factory configured processor register. The result can be used to program a fan speed control component. See the processor datasheet for further details on reading the register and calculating $T_{CONTROL}$.

See Chapter 6 *Intel® Quiet System Technology (Intel® QST)* for details on implementing a design using $T_{CONTROL}$ and the Thermal Profile.

2.3 Heatsink Design Considerations

To remove the heat from the processor, three basic parameters should be considered:

- **The area of the surface on which the heat transfer takes place.** Without any enhancements, this is the surface of the processor package IHS. One method used to improve thermal performance is by attaching a heatsink to the IHS. A heatsink can increase the effective heat transfer surface area by conducting heat out of the IHS and into the surrounding air through fins attached to the heatsink base.
- **The conduction path from the heat source to the heatsink fins.** Providing a direct conduction path from the heat source to the heatsink fins and selecting materials with higher thermal conductivity typically improves heatsink performance. The length, thickness, and conductivity of the conduction path from the heat source to the fins directly impact the thermal performance of the heatsink. In particular, the quality of the contact between the package IHS and the heatsink base has a higher impact on the overall thermal solution performance as processor cooling requirements become stricter. Thermal interface material (TIM) is used to fill in the gap between the IHS and the bottom surface of the heatsink, and thereby improve the overall performance of the stack-up (IHS-TIM-Heatsink). With extremely poor heatsink interface flatness or roughness, TIM may not adequately fill the gap. The TIM thermal performance depends on its thermal conductivity as well as the pressure applied to it. Refer to Section 2.3.3 and Appendix C for further information on TIM and on bond line management between the IHS and the heatsink base.
- **The heat transfer conditions on the surface on which heat transfer takes place.** Convective heat transfer occurs between the airflow and the surface exposed to the flow. It is characterized by the local ambient temperature of the air, T_A , and the local air velocity over the surface. The higher the air velocity over the surface, and the cooler the air, the more efficient is the resulting cooling. The nature of the airflow can also enhance heat transfer via convection. Turbulent flow can provide improvement over laminar flow. In the case of a heatsink, the surface exposed to the flow includes in particular the fin faces and the heatsink base.

Liquid Cooling Technology typically incorporates a fan, an integrated pump with cold plate and an air radiator type heat exchanger. The design takes advantage of a pump to provide a uniform liquid-flow across the cold plate taking away the heat then go to the exchanger. Finally, a fan manages the airflow through the exchanger.

Active heatsinks typically incorporate a fan that helps manage the airflow through the heatsink.



Passive heatsink solutions require in-depth knowledge of the airflow in the chassis. Typically, passive heatsinks see lower air speed. These heatsinks are therefore typically larger (and heavier) than active heatsinks due to the increase in fin surface required to meet a required performance. As the heatsink fin density (the number of fins in a given cross-section) increases, the resistance to the airflow increases: it is more likely that the air travels around the heatsink instead of through it, unless air bypass is carefully managed. Using air-ducting techniques to manage bypass area can be an effective method for controlling airflow through the heatsink.

2.3.1 Heatsink Size

The size of the heatsink is dictated by height restrictions for installation in a system and by the real estate available on the motherboard and other considerations for component height and placement in the area potentially impacted by the processor heatsink. The height of the heatsink must comply with the requirements and recommendations published for the motherboard form factor of interest. Designing a heatsink to the recommendations may preclude using it in system adhering strictly to the form factor requirements, while still in compliance with the form factor documentation.

For the ATX/microATX form factor, it is recommended to use:

- The ATX motherboard keep-out footprint definition and height restrictions for enabling components, defined for the platforms designed with the LGA775 socket in Appendix G of this design guide.
- The motherboard primary side height constraints defined in the *ATX Specification V2.2* and the *microATX Motherboard Interface Specification V1.2* found at <http://www.formfactors.org/>.

The resulting space available above the motherboard is generally not entirely available for the heatsink. The target height of the heatsink must take into account airflow considerations (for fan performance for example) as well as other design considerations (air duct, etc.).

For BTX form factor, it is recommended to use:

- The BTX motherboard keep-out footprint definitions and height restrictions for enabling components for platforms designed with the LGA77 socket in Appendix G of this design guide.
- An overview of other BTX system considerations for thermal solutions can be obtained in the *Balanced Technology Extended (BTX) System Design Guide v1.0* found at <http://www.formfactors.org/>.

2.3.2 Package IHS Flatness

The package IHS flatness for the product is specified in the datasheet and can be used as a baseline to predict heatsink performance during the design phase.

Intel recommends testing and validating heatsink performance in full mechanical enabling configuration to capture any impact of IHS flatness change due to combined socket and heatsink loading. While socket loading alone may increase the IHS warpage, the heatsink preload redistributes the load on the package and improves the resulting IHS flatness in the enabled state.



2.3.3 Thermal Interface Material

Thermal interface material application between the processor IHS and the heatsink base is generally required to improve thermal conduction from the IHS to the heatsink. Many thermal interface materials can be pre-applied to the heatsink base prior to shipment from the heatsink supplier and allow direct heatsink attach, without the need for a separate thermal interface material dispense or attach process in the final assembly factory.

All thermal interface materials should be sized and positioned on the heatsink base in a way that ensures the entire processor IHS area is covered. It is important to compensate for heatsink-to-processor attach positional alignment when selecting the proper thermal interface material size.

When pre-applied material is used, it is recommended to have a protective application tape over it. This tape must be removed prior to heatsink installation.

2.4 System Thermal Solution Considerations

2.4.1 Chassis Thermal Design Capabilities

The Intel liquid cooling thermal solution assumes that chassis delivers a maximum T_A at the inlet of the processor heat exchanger (refer to Section 5.1.1). Table 1 shows the T_A requirements for the ALCT and the similar BTX solutions.

Table 1. Heatsink Inlet Temperature of Intel Reference Thermal Solutions

Topic	ATX ALCT	BTX Liquid Cooling
Heatsink Inlet Temperature	38 °C	35.5 °C

2.4.2 Improving Chassis Thermal Performance

The heat generated by components within the chassis must be removed to provide an adequate operating environment for both the processor and other system components. Moving air through the chassis brings in air from the external ambient environment and transports the heat generated by the processor and other system components out of the system. The number, size and relative position of fans and vents determine the chassis thermal performance, and the resulting ambient temperature around the processor. The size and type (passive or active) of the thermal solution and the amount of system airflow can be traded off against each other to meet specific system design constraints. Additional constraints are board layout, spacing, component placement, acoustic requirements and structural considerations that limit the thermal solution size. For more information, refer to the *ATX Thermal Design Suggestions* or *microATX Thermal Design Suggestions* or *Balanced Technology Extended (BTX) System Design Guide v1.0* documents available on the <http://www.formfactors.org/> web site.

In addition to passive heatsinks, fan heatsinks and system fans are other solutions that exist for cooling integrated circuit devices. For example, ducted blowers, heat



pipes and liquid cooling are all capable of dissipating additional heat. Due to their varying attributes, each of these solutions may be appropriate for a particular system implementation.

To develop a reliable, cost-effective thermal solution, thermal characterization and simulation should be carried out at the entire system level, accounting for the thermal requirements of each component. In addition, acoustic noise constraints may limit the size, number, placement, and types of fans that can be used in a particular design.

To ease the burden on thermal solutions, the Thermal Monitor feature and associated logic have been integrated into the silicon of the processor. By taking advantage of the Thermal Monitor feature, system designers may reduce thermal solution cost by designing to TDP instead of maximum power. Thermal Monitor attempts to protect the processor during sustained workload above TDP. Implementation options and recommendations are described in Chapter 4.

2.4.3 Summary

In summary, considerations in heatsink design include:

- The local ambient temperature T_A at the heatsink, which is a function of chassis design.
- The thermal design power (TDP) of the processor, and the corresponding maximum T_C as calculated from the thermal profile. These parameters are usually combined in a single lump cooling performance parameter, Ψ_{CA} (case to air thermal characterization parameter). More information on the definition and the use of Ψ_{CA} is given section 3.1
- Heatsink interface to IHS surface characteristics, including flatness and roughness.
- The performance of the thermal interface material used between the heatsink and the IHS.
- The required heatsink clip static load, between 18 lbf to 70 lbf throughout the life of the product (Refer to Section 2.1.2.2 for further information).
- Surface area of the heatsink.
- Heatsink material and technology.
- Volume of airflow over the heatsink surface area.
- Development of airflow entering and within the heatsink area.
- Physical volumetric constraints placed by the system

2.5 System Integration Considerations

Manufacturing with Intel® Components using 775-Land LGA Package and LGA775 Socket documentation provides Best Known Methods for all aspects LGA775 socket based platforms and systems manufacturing. Of particular interest for package and heatsink installation and removal is the *System Assembly* module. A video covering system integration is also available. Contact your Intel field sales representative for further information.



3 Thermal Metrology

This section discusses guidelines for testing thermal solutions, including measuring processor temperatures. In all cases, the thermal engineer must measure power dissipation and temperature to validate a thermal solution. To define the performance of a thermal solution the “thermal characterization parameter”, Ψ (“psi”) will be used.

3.1 Characterizing Cooling Performance Requirements

The idea of a “thermal characterization parameter”, Ψ (“psi”), is a convenient way to characterize the performance needed for the thermal solution and to compare thermal solutions in identical situations (same heat source and local ambient conditions). The thermal characterization parameter is calculated using total package power.

Note: Heat transfer is a three-dimensional phenomenon that can rarely be accurately and easily modeled by a single resistance parameter like Ψ .

The case-to-local ambient thermal characterization parameter value (Ψ_{CA}) is used as a measure of the thermal performance of the overall thermal solution that is attached to the processor package. It is defined by the following equation, and measured in units of °C/W:

$$\Psi_{CA} = (T_C - T_A) / P_D \text{ (Equation 1)}$$

Where:

- Ψ_{CA} = Case-to-local ambient thermal characterization parameter (°C/W)
- T_C = Processor case temperature (°C)
- T_A = Local ambient temperature in chassis at processor (°C)
- P_D = Processor total power dissipation (W) (assumes all power dissipates through the IHS)

The case-to-local ambient thermal characterization parameter of the processor, Ψ_{CA} , is comprised of Ψ_{CS} , the thermal interface material thermal characterization parameter, and of Ψ_{SA} , the sink-to-local ambient thermal characterization parameter:

$$\Psi_{CA} = \Psi_{CS} + \Psi_{SA} \text{ (Equation 2)}$$

Where:

Ψ_{CS} = Thermal characterization parameter of the thermal interface material (°C/W)

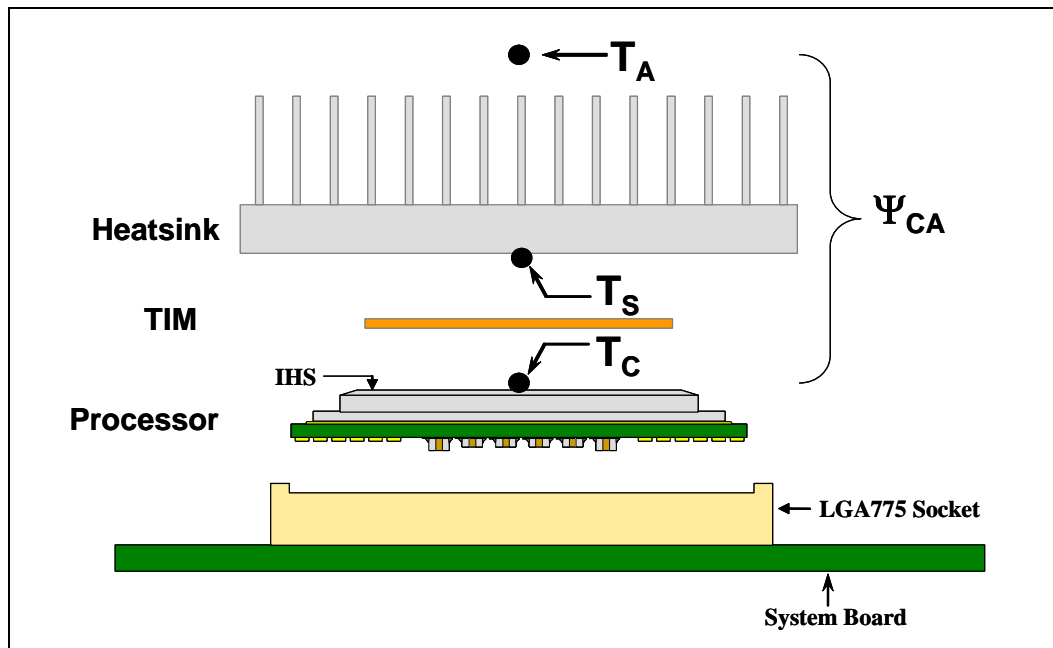
Ψ_{SA} = Thermal characterization parameter from heatsink-to-local ambient (°C/W)

Ψ_{CS} is strongly dependent on the thermal conductivity and thickness of the TIM between the heatsink and IHS.

Ψ_{SA} is a measure of the thermal characterization parameter from the bottom of the heatsink to the local ambient air. Ψ_{SA} is dependent on the heatsink material, thermal conductivity, and geometry. It is also strongly dependent on the air velocity through the fins of the heatsink.

Figure 4 illustrates the combination of the different thermal characterization parameters.

Figure 4. Processor Thermal Characterization Parameter Relationships





3.1.1 Example

The cooling performance, Ψ_{CA} , is then defined using the principle of thermal characterization parameter described above:

- The case temperature T_{C-MAX} and thermal design power TDP given in the processor datasheet.
- Define a target local ambient temperature at the processor, T_A .

Since the processor thermal profile applies to all processor frequencies, it is important to identify the worst case (lowest Ψ_{CA}) for a targeted chassis characterized by T_A to establish a design strategy.

The following provides an illustration of how one might determine the appropriate performance targets. The example power and temperature numbers used here are not related to any specific Intel processor thermal specifications, and are for illustrative purposes only.

Assume the TDP, as listed in the datasheet, is 100W and the maximum case temperature from the thermal profile for 100W is 67 °C. Assume as well that the system airflow has been designed such that the local ambient temperature is 38°C. Then the following could be calculated using equation 1 from above:

$$\Psi_{CA} = (T_{C,-} - T_A) / TDP = (67 - 38) / 100 = 0.29 \text{ } ^\circ\text{C/W}$$

To determine the required heatsink performance, a heatsink solution provider would need to determine Ψ_{CS} performance for the selected TIM and mechanical load configuration. If the heatsink solution were designed to work with a TIM material performing at $\Psi_{CS} \leq 0.10 \text{ } ^\circ\text{C/W}$, solving for equation 2 from above, the performance of the heatsink would be:

$$\Psi_{SA} = \Psi_{CA} - \Psi_{CS} = 0.29 - 0.10 = 0.19 \text{ } ^\circ\text{C/W}$$



3.2 Processor Thermal Solution Performance Assessment

Thermal performance of a heatsink should be assessed using a thermal test vehicle (TTV) provided by Intel. The TTV is a stable heat source that the user can make accurate power measurement, whereas processors can introduce additional factors that can impact test results. In particular, the power level from actual processors varies significantly, even when running the maximum power application provided by Intel, due to variances in the manufacturing process. The TTV provides consistent power and power density for thermal solution characterization and results can be easily translated to real processor performance. Accurate measurement of the power dissipated by an actual processor is beyond the scope of this document.

Once the thermal solution is designed and validated with the TTV, it is strongly recommended to verify functionality of the thermal solution on real processors and on fully integrated systems. The Intel maximum power application enables steady power dissipation on a processor to assist in this testing.

3.3 Local Ambient Temperature Measurement Guidelines

The local ambient temperature T_A is the temperature of the ambient air surrounding the processor. For a passive heatsink, T_A is defined as the heatsink approach air temperature; for an actively cooled heatsink, it is the temperature of inlet air to the active cooling fan; for a liquid cooled solution it is the temperature of the air entering the heat exchanger.

It is worthwhile to determine the local ambient temperature in the chassis around the processor to understand the effect it may have on the case temperature.

T_A is best measured by averaging temperature measurements at multiple locations in the heatsink or heat exchanger inlet airflow. This method helps reduce error and eliminate minor spatial variations in temperature. The following guidelines are meant to enable accurate determination of the localized air temperature around the processor during system thermal testing.

For **active heatsinks and liquid cooled solutions**, it is important to avoid taking measurement in the dead flow zone that usually develops above the fan hub and hub spokes. Measurements should be taken at four different locations uniformly placed at the center of the annulus formed by the fan hub and the fan housing to evaluate the uniformity of the air temperature at the fan inlet. The thermocouples should be placed approximately 3 mm to 8 mm [0.1 to 0.3 in] above the fan hub vertically and halfway between the fan hub and the fan housing horizontally as shown in Figure 5 and Figure 6 (avoiding the hub spokes). Using an open bench to characterize an active heatsink can be useful, and usually ensures more uniform temperatures at the fan inlet. However, additional tests that include a solid barrier above the test motherboard surface can help evaluate the potential impact of the chassis. This barrier is typically clear Plexiglas*, extending at least 100 mm [4 in] in all directions beyond the edge of the thermal solution. Typical distance from the motherboard to the barrier is 81 mm [3.2 in]. For even more realistic airflow, the motherboard should be populated with significant elements like memory cards, graphic card, and chipset

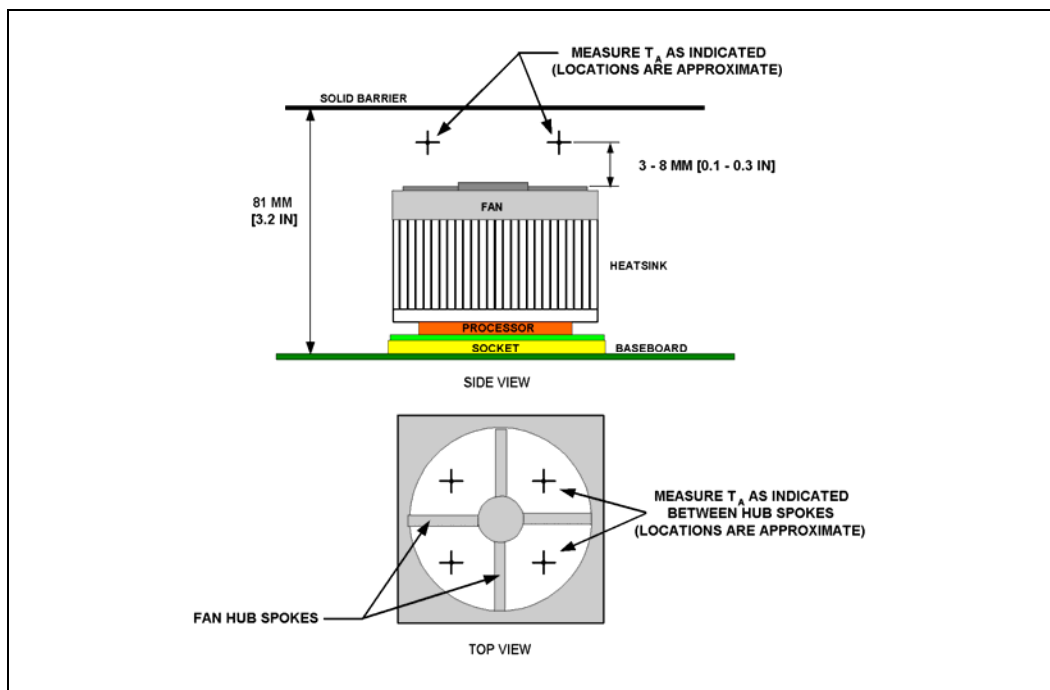


heatsink. If a barrier is used, the thermocouple can be taped directly to the barrier at the horizontal location as previously described, half way between the fan hub and the fan housing. If a variable speed fan is used, it may be useful to add a thermocouple taped to the barrier above the location of the temperature sensor used by the fan to check its speed setting against air temperature. When measuring T_A in a chassis with a live motherboard, add-in cards, and other system components, it is likely that the T_A measurements will reveal a highly non-uniform temperature distribution across the inlet fan section.

For **passive heatsinks**, thermocouples should be placed approximately 13 mm to 25 mm [0.5 to 1.0 in] away from processor and heatsink as shown in Figure 7. The thermocouples should be placed approximately 51 mm [2.0 in] above the baseboard. This placement guideline is meant to minimize the effect of localized hot spots from baseboard components.

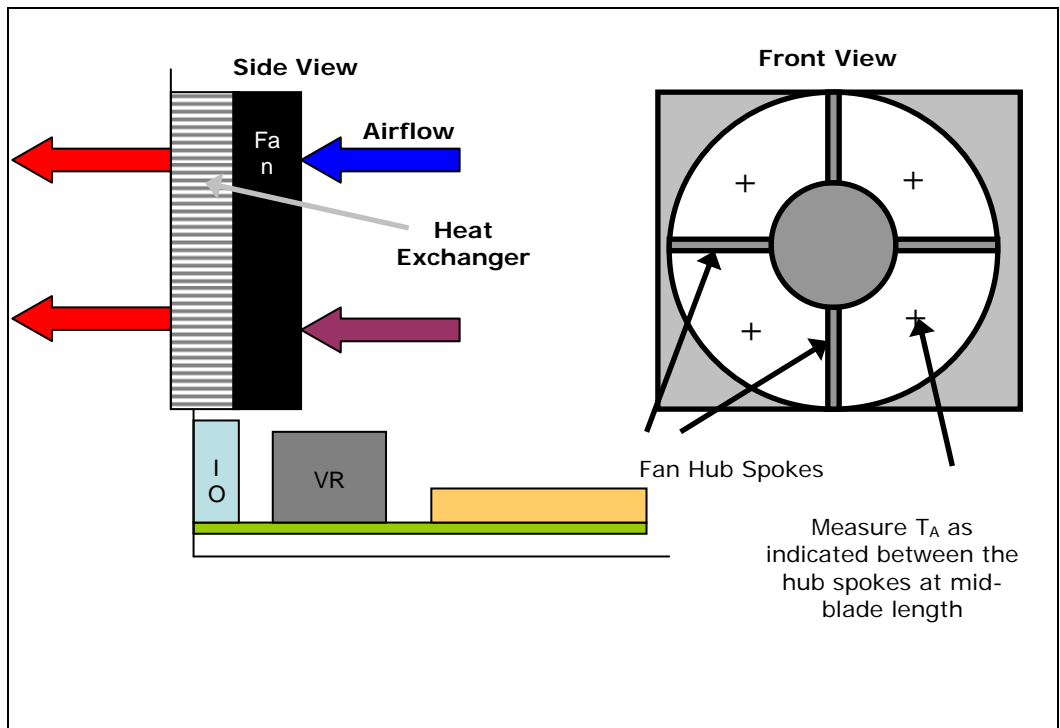
Note: Testing an active heatsink with a variable speed fan can be done in a thermal chamber to capture the worst-case thermal environment scenarios. Otherwise, when doing a bench top test at room temperature, the fan regulation prevents the heatsink from operating at its maximum capability. To characterize the heatsink capability in the worst-case environment in these conditions, it is then necessary to disable the fan regulation and power the fan directly, based on guidance from the fan supplier.

Figure 5. Locations for Measuring Local Ambient Temperature, Active Heatsink



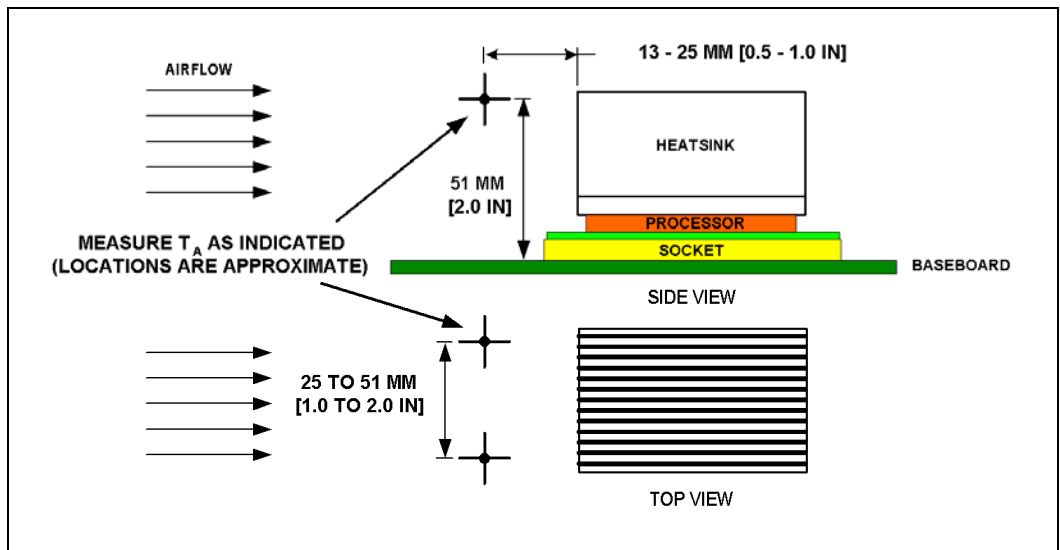
NOTE: Drawing Not to Scale

Figure 6. Locations for Measuring Local Ambient Temperature, Liquid-Cooling Heat Exchanger



NOTE: Drawing Not to Scale

Figure 7. Locations for Measuring Local Ambient Temperature, Passive Heatsink



NOTE: Drawing Not to Scale



3.4 Processor Case Temperature Measurement Guidelines

To ensure functionality and reliability, the processor is specified for proper operation when T_C is maintained at or below the thermal profile as listed in the datasheet. The measurement location for T_C is the geometric center of the IHS. Figure 2 shows the location for T_C measurement.

Special care is required when measuring T_C to ensure an accurate temperature measurement. Thermocouples are often used to measure T_C . Before any temperature measurements are made, the thermocouples must be calibrated, and the complete measurement system must be routinely checked against known standards. When measuring the temperature of a surface that is at a different temperature from the surrounding local ambient air, errors could be introduced in the measurements. The measurement errors could be caused by poor thermal contact between the junction of the thermocouple and the surface of the integrated heat spreader, heat loss by radiation, convection, by conduction through thermocouple leads, or by contact between the thermocouple cement and the heatsink base.

Appendix D defines a reference procedure for attaching a thermocouple to the IHS of a 775-Land LGA processor package for T_C measurement. This procedure takes into account the specific features of the 775-Land LGA package and of the LGA775 socket for which it is intended.

§





4 Thermal Management Logic and Thermal Monitor Feature

4.1 Processor Power Dissipation

An increase in processor operating frequency not only increases system performance, but also increases the processor power dissipation. The relationship between frequency and power is generalized in the following equation: $P = CV^2F$ (where P = power, C = capacitance, V = voltage, F = frequency). From this equation, it is evident that power increases linearly with frequency and with the square of voltage. In the absence of power saving technologies, ever increasing frequencies will result in processors with power dissipations in the hundreds of watts. Fortunately, there are numerous ways to reduce the power consumption of a processor, and Intel is aggressively pursuing low power design techniques. For example, decreasing the operating voltage, reducing unnecessary transistor activity, and using more power efficient circuits can significantly reduce processor power consumption.

An on-die thermal management feature called Thermal Monitor is available on the processor. It provides a thermal management approach to support the continued increases in processor frequency and performance. By using a highly accurate on-die temperature sensing circuit and a fast acting Thermal Control Circuit (TCC), the processor can rapidly initiate thermal management control. The Thermal Monitor can reduce cooling solution cost, by allowing thermal designs to target TDP.

The processor also supports an additional power reduction capability known as Thermal Monitor 2 described in Section 4.2.3.

4.2 Thermal Monitor Implementation

The Thermal Monitor consists of the following components:

- A highly accurate on-die temperature sensing circuit
- A bi-directional signal (PROCHOT#) that indicates if the processor has exceeded its maximum temperature or can be asserted externally to activate the Thermal Control Circuit (TCC) (see Section 4.2.1 for more details on user activation of TCC via PROCHOT# signal)
- FORCEPR# signal that will activate the TCC.
- A Thermal Control Circuit that will attempt to reduce processor temperature by rapidly reducing power consumption when the on-die temperature sensor indicates that it has exceeded the maximum operating point.
- Registers to determine the processor thermal status.



4.2.1 PROCHOT# Signal

The primary function of the PROCHOT# signal is to provide an external indication that the processor has exceeded its maximum operating temperature. While PROCHOT# is asserted, the TCC will be active. Assertion of the PROCHOT# signal is independent of any register settings within the processor. It is asserted any time the processor die temperature reaches the trip point.

PROCHOT# can be configured via BIOS as an output or bi-directional signal. As an output, PROCHOT# will go active when the processor temperature of either core exceeds its maximum operating temperature. This indicates the TCC has been activated. As an input, assertion of PROCHOT# will activate the TCC for both cores. The TCC will remain active until the system de-asserts PROCHOT#

The temperature at which the PROCHOT# signal goes active is individually calibrated during manufacturing. The power dissipation of each processor affects the set point temperature. The temperature where PROCHOT# goes active roughly parallels the thermal profile. Once configured, the processor temperature at which the PROCHOT# signal is asserted is not re-configurable.

One application is the thermal protection of voltage regulators (VR). System designers can create a circuit to monitor the VR temperature and activate the TCC when the temperature limit of the VR is reached. By asserting PROCHOT# (pulled-low) or FORCEPR#, which activates the TCC, the VR can cool down as a result of reduced processor power consumption. Bi-directional PROCHOT# can allow VR thermal designs to target maximum sustained current instead of maximum current. Systems should still provide proper cooling for the VR, and rely on bi-directional PROCHOT# signal only as a backup in case of system cooling failure.

Note: A thermal solution designed to meet the thermal profile targets should rarely experience activation of the TCC as indicated by the PROCHOT# signal going active.

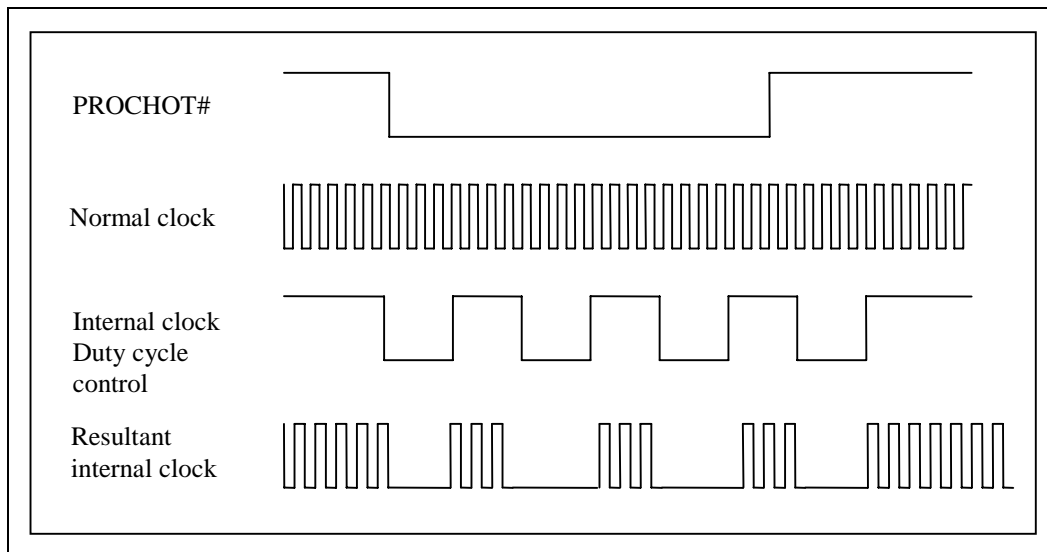
4.2.2 Thermal Control Circuit

The Thermal Control Circuit portion of the Thermal Monitor must be enabled for the processor to operate within specifications. The Thermal Monitor's TCC, when active, will attempt to lower the processor temperature by reducing the processor power consumption. In the original implementation of thermal monitor this is done by changing the duty cycle of the internal processor clocks, resulting in a lower effective frequency. When active, the TCC turns the processor clocks off and then back on with a predetermined duty cycle. The duty cycle is processor specific, and is fixed for a particular processor. The maximum time period the clocks are disabled is ~3 μ s. This time period is frequency dependent and higher frequency processors will disable the internal clocks for a shorter time period. Figure 8 illustrates the relationship between the internal processor clocks and PROCHOT#.

Performance counter registers, status bits in model specific registers (MSRs), and the PROCHOT# output pin are available to monitor the Thermal Monitor behavior.



Figure 8. Concept for Clocks under Thermal Monitor Control



4.2.3 Thermal Monitor 2

The processor supports an enhanced Thermal Control Circuit. In conjunction with the existing Thermal Monitor logic, this capability is known as Thermal Monitor 2. This enhanced TCC provides an efficient means of reducing the power consumption within the processor and limiting the processor temperature.

When Thermal Monitor 2 is enabled, and a high temperature situation is detected, the enhanced TCC will be activated. The enhanced TCC causes the processor to adjust its operating frequency (by dropping the bus-to-core multiplier to its minimum available value) and input voltage identification (VID) value. This combination of reduced frequency and VID results in a reduction in processor power consumption.

A processor enabled for Thermal Monitor 2 includes two operating points, each consisting of a specific operating frequency and voltage. The first operating point represents the normal operating condition for the processor.

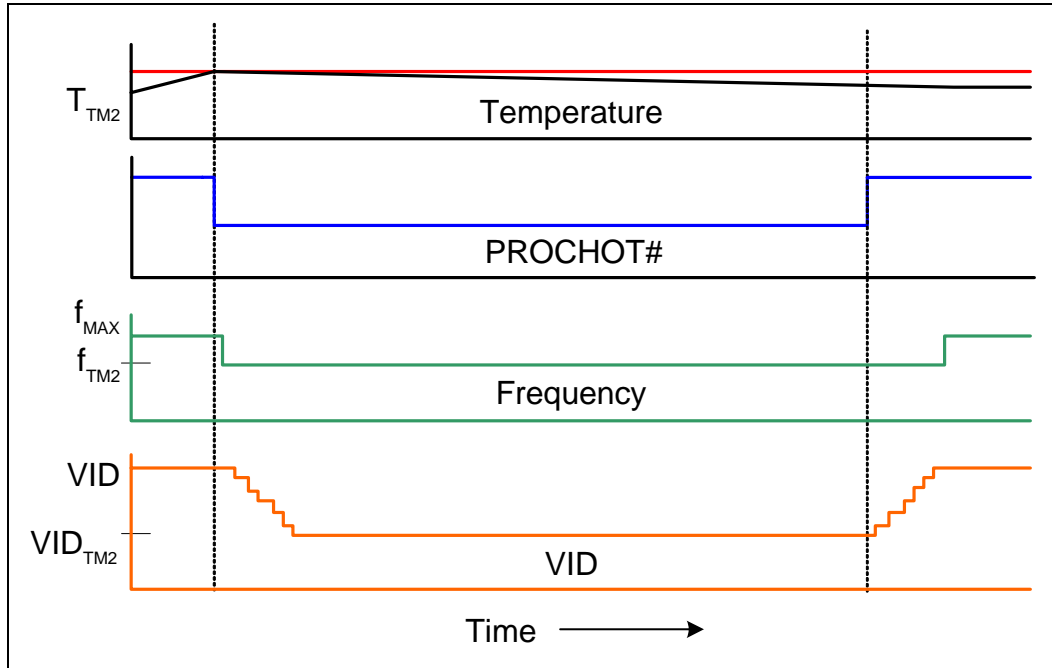
The second operating point consists of both a lower operating frequency and voltage. When the TCC is activated, the processor automatically transitions to the new frequency. This transition occurs very rapidly (on the order of 5 microseconds). During the frequency transition, the processor is unable to service any bus requests, all bus traffic is blocked. Edge-triggered interrupts will be latched and kept pending until the processor resumes operation at the new frequency.

Once the new operating frequency is engaged, the processor will transition to the new core operating voltage by issuing a new VID code to the voltage regulator. The voltage regulator must support VID transitions in order to support Thermal Monitor 2. During the voltage change, it will be necessary to transition through multiple VID codes to reach the target operating voltage. Each step will be one VID table entry (i.e., 12.5 mV steps). The processor continues to execute instructions during the voltage transition. Operation at the lower voltage reduces the power consumption of the processor, providing a temperature reduction.

Once the processor has sufficiently cooled, and a minimum activation time has expired, the operating frequency and voltage transition back to the normal system operating point. Transition of the VID code will occur first, in order to insure proper operation once the processor reaches its normal operating frequency. Refer to Figure 9 for an illustration of this ordering.

Refer to the datasheet for further information on Thermal Monitor 2.

Figure 9. Thermal Monitor 2 Frequency and Voltage Ordering



4.2.4 Operation and Configuration

To maintain compatibility with previous generations of processors, which have no integrated thermal logic, the Thermal Control Circuit portion of Thermal Monitor is disabled by default. During the boot process, the BIOS must enable the Thermal Control Circuit. **Thermal Monitor must be enabled to ensure proper processor operation.**

The Thermal Control Circuit feature can be configured and monitored in a number of ways. OEMs are required to enable the Thermal Control Circuit while using various registers and outputs to monitor the processor thermal status. The Thermal Control Circuit is enabled by the BIOS setting a bit in an MSR (model specific register). Enabling the Thermal Control Circuit allows the processor to attempt to maintain a safe operating temperature without the need for special software drivers or interrupt handling routines. When the Thermal Control Circuit has been enabled, processor power consumption will be reduced after the thermal sensor detects a high temperature, i.e. PROCHOT# assertion. The Thermal Control Circuit and PROCHOT# transitions to inactive once the temperature has been reduced below the thermal trip point, although a small time-based hysteresis has been included to prevent multiple PROCHOT# transitions around the trip point. External hardware can monitor



PROCHOT# and generate an interrupt whenever there is a transition from active-to-inactive or inactive-to-active. PROCHOT# can also be configured to generate an internal interrupt which would initiate an OEM supplied interrupt service routine. Regardless of the configuration selected, PROCHOT# will always indicate the thermal status of the processor.

The power reduction mechanism of thermal monitor can also be activated manually using an “on-demand” mode. Refer to Section 4.2.5 for details on this feature.

4.2.5 On-Demand Mode

For testing purposes, the thermal control circuit may also be activated by setting bits in the ACPI MSR. The MSRs may be set based on a particular system event (e.g., an interrupt generated after a system event), or may be set at any time through the operating system or custom driver control thus forcing the thermal control circuit on. This is referred to as “on-demand” mode. Activating the thermal control circuit may be useful for thermal solution investigations or for performance implication studies. When using the MSRs to activate the on-demand clock modulation feature, the duty cycle is configurable in steps of 12.5%, from 12.5% to 87.5%.

For any duty cycle, the maximum time period the clocks are disabled is $\sim 3 \mu\text{s}$. This time period is frequency dependent, and decreases as frequency increases. To achieve different duty cycles, the length of time that the clocks are disabled remains constant, and the time period that the clocks are enabled is adjusted to achieve the desired ratio. For example, if the clock disable period is $3 \mu\text{s}$, and a duty cycle of $\frac{1}{4}$ (25%) is selected, the clock on time would be reduced to approximately $1 \mu\text{s}$ [on time ($1 \mu\text{s}$) \div total cycle time ($3 + 1 \mu\text{s}$) = $\frac{1}{4}$ duty cycle]. Similarly, for a duty cycle of $\frac{7}{8}$ (87.5%), the clock on time would be extended to $21 \mu\text{s}$ [$21 \div (21 + 3) = \frac{7}{8}$ duty cycle].

In a high temperature situation, if the thermal control circuit and ACPI MSR (automatic and on-demand modes) are used simultaneously, the fixed duty cycle determined by automatic mode would take precedence.

Note: On-demand mode can not activate the power reduction mechanism of Thermal Monitor 2

4.2.6 System Considerations

Intel requires the Thermal Monitor and Thermal Control Circuit to be enabled for all processors. The thermal control circuit is intended to protect against short term thermal excursions that exceed the capability of a well designed processor thermal solution. Thermal Monitor should not be relied upon to compensate for a thermal solution that does not meet the thermal profile up to the thermal design power (TDP).

Each application program has its own unique power profile, although the profile has some variability due to loop decisions, I/O activity and interrupts. In general, compute intensive applications with a high cache hit rate dissipate more processor power than applications that are I/O intensive or have low cache hit rates.

The processor TDP is based on measurements of processor power consumption while running various high power applications. This data is used to determine those applications that are interesting from a power perspective. These applications are then evaluated in a controlled thermal environment to determine their sensitivity to



activation of the thermal control circuit. This data is used to derive the TDP targets published in the processor datasheet.

A system designed to meet the thermal profile at TDP and T_{C-MAX} values published in the processor datasheet greatly reduces the probability of real applications causing the thermal control circuit to activate under normal operating conditions. Systems that do not meet these specifications could be subject to more frequent activation of the thermal control circuit depending upon ambient air temperature and application power profile. Moreover, if a system is significantly under designed, there is a risk that the Thermal Monitor feature will not be capable of maintaining a safe operating temperature and the processor could shutdown and signal THERMTRIP#.

For information regarding THERMTRIP#, refer to the processor datasheet and to Section 4.2.8 of this Thermal Design Guidelines.

4.2.7 Operating System and Application Software Considerations

The Thermal Monitor feature and its thermal control circuit work seamlessly with ACPI compliant operating systems. The Thermal Monitor feature is transparent to application software since the processor bus snooping, ACPI timer, and interrupts are active at all times.

4.2.8 THERMTRIP# Signal

In the event of a catastrophic cooling failure, the processor will automatically shut down when the silicon temperature has reached its operating limit. At this point the system bus signal THERMTRIP# goes active and power must be removed from the processor. THERMTRIP# activation is independent of processor activity and does not generate any bus cycles. Refer to the processor datasheet for more information about THERMTRIP#.

The temperature where the THERMTRIP# signal goes active is individually calibrated during manufacturing. The temperature where THERMTRIP# goes active is roughly parallel to the thermal profile and greater than the PROCHOT# activation temperature. Once configured, the temperature at which the THERMTRIP# signal is asserted is neither re-configurable nor accessible to the system.

4.2.9 Cooling System Failure Warning

It may be useful to use the PROCHOT# signal as an indication of cooling system failure. Messages could be sent to the system administrator to warn of the cooling failure, while the thermal control circuit would allow the system to continue functioning or allow a normal system shutdown. If no thermal management action is taken, the silicon temperature may exceed the operating limits, causing THERMTRIP# to activate and shut down the processor. Regardless of the system design requirements or thermal solution ability, the Thermal Monitor feature must still be enabled to ensure proper processor operation.



4.2.10 Digital Thermal Sensor

The processor utilizes the Digital Thermal Sensor (DTS) as the on-die sensor to use for fan speed control (FSC). The DTS replaces the on-die thermal diode used in previous product. The DTS is monitoring the same sensor that activates the TCC (See Section 4.2.2). Readings from the DTS are relative to the activation of the TCC. The DTS value where TCC activation occurs is 0 (zero).

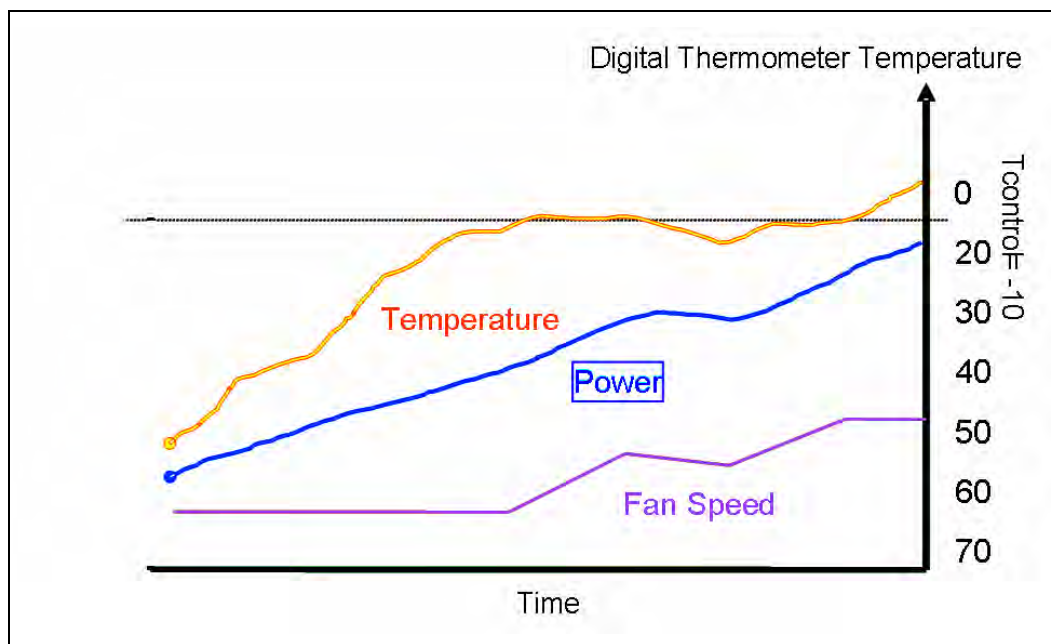
The DTS can be accessed by two methods. The first is via a MSR. The value read via the MSR is an unsigned number of degrees C away from TCC activation. The second method which is expected to be the primary method for FSC is via the PECCI interface. The value of the DTS when read via the PECCI interface is always negative and again is degrees C away from TCC activation.

A T_{CONTROL} value will be provided for use with DTS. The usage model for T_{CONTROL} with the DTS is the same as with the on-die thermal diode:

- If the Digital Thermometer is less than T_{CONTROL} , the fan speed can be reduced.
- If the Digital Thermometer is greater than or equal to T_{CONTROL} , then T_{C} must be maintained at or below the Thermal Profile for the measured power dissipation.

The calculation of T_{CONTROL} is slightly different from previous product. There is no base value to sum with the T_{OFFSET} located in the same MSR as used in previous processors. The BIOS only needs to read the T_{OFFSET} MSR and provide this value to the fan speed control device.

Figure 10. T_{CONTROL} for Digital Thermometer



Multiple digital thermal sensors can be implemented within the package without adding a pair of signal pins per sensor as required with the thermal diode. The digital thermal sensor is easier to place in thermally sensitive locations of the processor than the thermal diode. This is achieved due to a smaller foot print and decreased sensitivity to noise. Since the DTS is factory set on a per-part basis there is no need for the health monitor components to be updated at each processor family.



Note: Intel® Core™2 Extreme processor QX6800 B3 stepping and QX9770 C0 stepping **do not have an on-die thermal diode**. The T_{CONTROL} in the MSR is relevant only to the DTS.

4.2.11 Platform Environmental Control Interface (PECI)

The PECI interface is a proprietary single wire bus between the processor and the chipset or other health monitoring device. At this time the digital thermal sensor is the only data being transmitted. For an overview of the PECI interface see *PECI Feature Set Overview*. For additional information on the PECI see the processor datasheet.

The PECI bus is available on pin G5 of the LGA 775 socket. Intel chipsets beginning with the ICH8 have included PECI host controller. The PECI interface and the Manageability Engine are key elements to the *Intel® Quiet System Technology (Intel® QST)*, see Chapter 6 and the *Intel® Quiet System Technology (Intel® QST) Configuration and Tuning Manual*.

Intel has worked with many vendors that provide fan speed control devices to provide PECI host controllers. Consult the local representative for your preferred vendor for their product plans and availability.

§



5 Intel Thermal/Mechanical Reference Design Information

The Intel Advanced Liquid Cooling Technology or ALCT is composed of three components: a liquid to air radiator type heat exchanger; a 120mm fan; and an integrated pump with cold plate. The heat exchanger is connected to the pump with flexible hoses.

The heart of the design is the integrated pump cold plate combination. The cold plate is nested within a centrifugal pump impeller. This unique design takes advantage of the radial pull of the impeller to provide a uniform flow across the cold plate. The inlet flow returning from the heat exchanger impinges on the center of the cold plate. The centrifugal impeller then pulls the fluid across and through the cold plate fins. The fins in turn act as an inducer for the impeller. The fluid is then accelerated through the impeller and collected in a double involute and returned to the exchanger.

There are several unique features of the design in addition to the integration of pump and cold plate. There are no dynamic seals in the pump. The impeller is an integral part of the motor and is directly driven through a magnetic couple. There are no seals between the upper and lower pump housings. The seal is a function of the molding process. The copper cold plate is molded into the lower housing. The metal to plastic seal is also a function of the molding process.

The unit is maintenance free. Through careful selection of materials and the unique heat exchanger design that contains a reservoir the units are sealed for life. In addition every unit is proof pressure tested, vacuum decay tested, helium leak checked and the motor RPM is verified.

5.1 Validation Results for the ATX Reference Design

The reference thermal solution is a liquid cooled design, with an integrated pump and cold-plate (or chiller) and a remote heat exchanger with an attached fan. This solution is called the Intel Advanced Liquid Cooling Technology Reference Design (Intel ALCT Reference Design).

The reference solution pump and cold-plate module is compliant with the reference ATX motherboard keep-out and height recommendations defined Section 5.5 through the tubing that carries the working fluid from the pump/cold-plate protrudes through this keep-out and the heat exchanger is located on the back panel of the chassis.

The solution comes as an integrated assembly. The major ALCT components are provided Figure 16.

Note: If this fan design is used in your product and you will deliver it to end use customers, you have the responsibility to determine an adequate level of protection (e.g., protection barriers, a cage, or an interlock) against contact with the energized fan by the user during user servicing.



5.1.1 Heatsink Performance

Table 2 provides the Intel ALCT Reference Design performance for the Intel® Core™2 Extreme processor QX6800 B3 Stepping and QX9770 C0 Stepping. The results are based on the test procedure described in Section 5.1.4.

The table also includes a T_A assumption of 38 °C for the Intel reference thermal solution at the inlet to the heat exchanger fan discussed in Section 3.3. An external ambient temperature to the chassis of 35 °C is assumed, resulting in a temperature rise, T_R , of 3 °C. Meeting T_A and Ψ_{CA} targets can maximize processor performance (refer to Sections 2.2, 2.4. and Chapter 4). Minimizing T_R , can lead to improved acoustics.

Table 2. Intel Liquid Cooled Reference Design Performance (ALCT)

Processor	Target Thermal Performance, Ψ_{ca} (Mean + 3 σ)	T_A Assumption
Intel® Core™ 2 Extreme processor QX6800 B3 stepping	0.13 °C/W	$T_A = 38\text{ °C}$
Intel® Core™ 2 Extreme processor QX9770 C0 stepping	0.13 °C/W	$T_A = 38\text{ °C}$

5.1.2 Acoustics

To optimize acoustic emission by the heat exchanger fan and pump, the reference design implements a variable speed fan and pump. A variable speed fan and pump allows the reference design performance to adjust for changes in processor utilization and ambient air conditions. The required fan speed necessary to meet thermal specifications can be controlled by the silicon sensor temperature and should comply with requirements in Table 3.

Table 3. Acoustic Results

Fan Speed PWM (RPM)	Pump Speed PWM (RPM)	Acoustic	Thermal Performance Ψ_{ca}	Descriptions
100% (3300)	100% (1700)	6.0BA	0.13 °C/W	Maximum fan and pump speed
25% (900)	25% (600)	3.6BA	~0.23 °C/W	Minimum fan and pump speed

NOTES:

1. Acoustic performance is defined in terms of measured sound power (L_{wAm}) as defined in ISO 9296 standard, and measured according to ISO 7779.
2. Pump speed represents 3 pulses per rotation and if read by MB circuitry that assumes 2 pulses per rotation. It will perceive its operating (rotating) faster than specified in the table (e.g., the real pump speed is 600 rpm, 3 pulses, but MB would report 900rpm per 2 pulses calculated.)
3. If only 3 pin headers are available on MB that operate at a constant 12 V, the fan and pump will operate at full speed and this condition does not represent the minimum speed. The design is intended to run using 4 pin header PWM signals specified in Sections 5.1.5 and 5.1.6.
4. If only one 4 pin header is available on MB (all others are 3 pin headers), it is recommended to run the pump off of the 4 pin header and the fan off of the 3 pin header and to have both headers respond to the CPU temperature to deliver the performance indicated in Table 3.



This design does not use a fan hub thermistor. Additional acoustic improvements can be achieved at lower processor workload by using the T_{CONTROL} specifications described in section 2.2.3. Intel recommendation is to use the *Fan Specification for 4 Wire PWM Controlled Fans* to implement fan speed control capability based on the digital thermal sensor. Refer to Chapter 6 for further details.

5.1.3 Altitude

The reference heatsink solutions were evaluated at sea level. However, many companies design products that must function reliably at high altitude, typically 1,500 m [5,000 ft] or more. Air-cooled temperature calculations and measurements at sea level must be adjusted to take into account altitude effects like variation in air density and overall heat capacity. This often leads to some degradation in thermal solution performance compared to what is obtained at sea level, with lower fan performance and higher surface temperatures. The system designer needs to account for altitude effects in the overall system thermal design to make sure that the T_c requirement for the processor is met at the targeted altitude.

5.1.4 Reference Heatsink Thermal Validation

The Intel reference heatsink was validated within the specific boundary conditions based on the methodology described Section 5.2, and using a thermal test vehicle (refer to section **Error! Reference source not found.**).

Thermal testing is done in a thermal chamber (due to the slight change in fluid properties at elevated temperatures) on test fixtures to secure the heat exchangers at the appropriate ambient temperatures. Acoustic testing is completed in an ATX chassis representing a micro-tower configuration.

The test results, for a number of samples, are reported in terms of a worst-case mean + 3σ value for thermal characterization parameter using real processors (based on the thermal test vehicle correction factors).



5.1.5 Fan Motor Performance

The fan power requirements for proper operation are given Table 4.

Table 4. Fan Electrical Performance Requirements

Requirement	Value
Maximum Average fan current draw	1.5 A
Fan start-up current draw	2.2 A
Fan start-up current draw maximum duration	1.0 second
Fan header voltage	12 V \pm 5%
Tachometer output	2 pulse per revolution
Tachometer output signal	Open-collector (open-drain)
PWM signal input frequency	21 kHz to 28 kHz
PWM signal pull up in fan	3.3 V (recommended max); 5.25 V (absolute max)
PWM signal current source	I _{max} = 5 mA (short circuit current)
PWM signal maximum voltage for logic low	V _{IL} = 0.8 V
PWM compliant function	RPM must be within spec for specified duty cycle

In addition to comply with overall thermal requirements (see Section 5.1.1), and the general environmental reliability requirements (see Section 5.2) the fan should meet the following performance requirements:

- Mechanical wear out represents the highest risk reliability parameter for fans. The capability of the functional mechanical elements (ball bearing, shaft, and tower assembly) must be demonstrated to a minimum useful lifetime of 50,000 hours.
- In addition to passing the environmental reliability tests described in Section 5.2, the fan must demonstrate adequate performance after 7,500 on/off cycles with each cycle specified as 3 minutes on, 2 minutes off, at a temperature of 70 °C.

See the *Fan Specification for 4-wire PWM Controlled Fans* for additional details on the fan specification.



5.1.6 Pump Motor Performance

The pump power requirements for proper operation are given Table 5

Table 5. Pump Electrical Performance Requirements

Requirement	Value
Maximum Average motor current draw	1.5 A
Motor start-up current draw	2.2 A
Motor header voltage	12 V \pm 5%
Tachometer output	3 pulse per revolution
Tachometer output signal	Open-collector (open-drain)
Tachometer output signal current sink capability	10 mA
PWM signal input frequency	25 kHz (nominal) 21 kHz to 28kHz (allowable range)
PWM signal pull up in fan	3.3 V (recommended max) 5.25 V (absolute max)
PWM signal current source	$I_{max} = 5$ mA (short circuit current)
PWM signal maximum voltage for logic low	VIL = 0.8 V
PWM compliant function	RPM must be within spec for specified duty cycle

In addition to comply with overall thermal requirements (see section 5.1.1), the pump should meet the environment reliability requirements (see Section 5.2).



5.2 Environmental Reliability Testing

5.2.1 Structural Reliability Testing

Structural reliability tests consist of unpackaged, board-level vibration and shock tests of a given thermal solution in the assembled state. The thermal solution should meet the specified thermal performance targets after these tests are conducted; however, the test conditions outlined here may differ from your own system requirements.

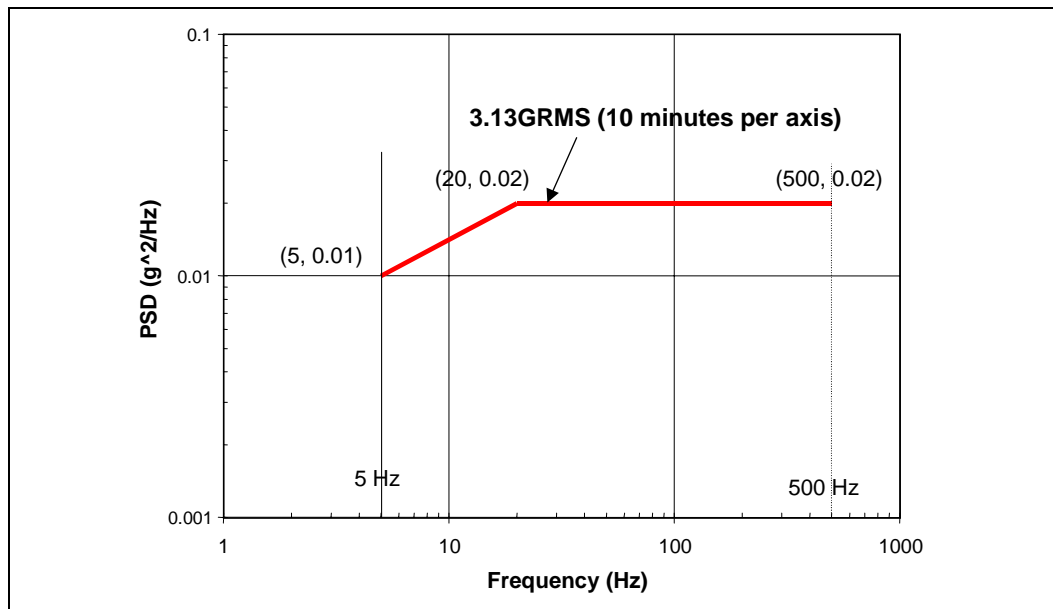
5.2.1.1 Random Vibration Test Procedure

Duration: 10 min/axis, 3 axes

Frequency Range: 5 Hz to 500 Hz

Power Spectral Density (PSD) Profile: 3.13 G RMS

Figure 11. Random Vibration PSD



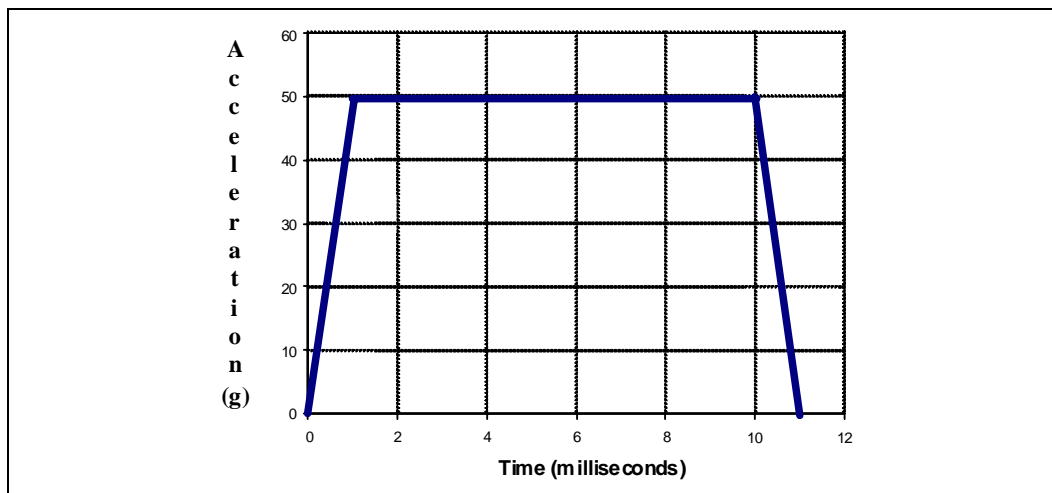


5.2.1.2 Shock Test Procedure

Recommended performance requirement for a motherboard:

- Quantity: 3 drops for + and - directions in each of 3 perpendicular axes (i.e., total 18 drops).
- Profile: 50 G trapezoidal waveform, 11 ms duration, 170 in/sec minimum velocity change.
- Setup: Mount sample board on test fixture.

Figure 12. Shock Acceleration Curve



5.2.1.2.1 Recommended Test Sequence

Each test sequence should start with components (i.e., motherboard, heatsink assembly, etc.) that have never been previously submitted to any reliability testing.

The test sequence should always start with a visual inspection after assembly, and BIOS/CPU/Memory test (refer to Section 5.2.3).

Prior to the mechanical shock & vibration test, the units under test should be preconditioned for 72 hours at 45 °C. The pre-conditioning is intended to present the system burn-in and shipping/storage environment stress.

The stress test should be followed by a visual inspection and then BIOS/CPU/Memory test.



5.2.1.2.2 Post-Test Pass Criteria

The post-test pass criteria are:

1. No significant physical damage to the pump assembly attach mechanism (including such items as clip and motherboard fasteners).
2. The assembly must remain attached to the motherboard.
3. The assembly remains seated and its bottom remains mated flatly against IHS surface. No visible gap between the heatsink base and processor IHS. No visible tilt of the heatsink with respect to its attach mechanism.
4. No signs of physical damage on motherboard surface due to impact of the assembly or its attach mechanism.
5. No visible physical damage to the processor package.
6. Successful BIOS/Processor/memory test of post-test samples.
7. Thermal compliance testing to demonstrate that the case temperature specification can be met.

5.2.2 Power Cycling

Thermal performance degradation due to TIM degradation is evaluated using power cycling testing. The test is defined by 7500 cycles for the case temperature from room temperature (~23 °C) to the maximum case temperature defined by the thermal profile at TDP. Thermal Test Vehicle (refer to Section **Error! Reference source not found.**) is used for this test.

5.2.3 Reliability Testing

The ALCT solution is a complex assembly with multiple joints and injection molded plastic parts. The selection of materials for pump and tubing as well as joint designs are done to provide a liquid-tight environment and to minimize the loss of liquid to ambient through vapor transmission. A reservoir is included in the heat exchanger to mitigate the impact of the vapor transmission loss. The design approach that is used for the selection of tubing and for reservoir sizing based on reliability testing is shown in Table 6. The results of the reliability testing and their impact on thermal resistance pump motor performance and on pump integrity are summarized.

The complex assembly of ALCT and the sensitivity of reliability to manufacturing environment would require frequent verification of parts for reliability. The objective of the reliability testing of the design is to identify key failure mechanisms and to develop design paths to mitigate them under a reasonable set of use conditions. The reliability testing and results are not expected to represent the performance of the design and may require additional testing to verify the performance in a particular use condition environment.



A list of failure mechanisms that were considered in design reliability testing are:

1. Pump assembly cracking causing liquid loss
2. Vapor loss through plastic walls and joints causing liquid loss
3. Thermal performance degradation due to internal mechanisms affecting CPU T_C temperature
4. Pump motor and printed circuit board performance degradation affecting the pump RPM

All of the above mechanisms are expected to be active during the pump operation and relatively inactive during the off mode and so all reliability testing needs to be performed with pump on. The fatigue mechanisms (# 1) are additionally excited by the cycling of temperature caused by on-off cycles. The real use condition is a combination of continuous operation and on-off cycling and for the purpose of testing can be separated into a) continuous operation and b) on-off power cycles. The liquid temperature during continuous operation can be estimated by the heat exchanger thermal resistance, TDP, and T_A (e.g., at $T_A = 38\text{ }^\circ\text{C}$, TDP = 130 W, and $\Psi_{HX} = 0.05\text{ }^\circ\text{C/W}$ gives $T_{LIQUID} = 45\text{ }^\circ\text{C}$). The calculated T_{LIQUID} when fan is at its low speed and $T_A = 26\text{ }^\circ\text{C}$ is expected to be approximately the same. A typical on-off cycle can be assumed to be from ambient condition to $T_{LIQUID} = 45\text{ }^\circ\text{C}$. The pump speed is also controlled similar to a fan for acoustics and expected mean pump RPM was estimated to be 1450 (range = 600-1700). The pump speed of 1450 was used to simulate typical condition during with use condition.

Note: The heat exchanger thermal resistance, $\Psi_{HX} = (T_{LIQUID} - T_A) / (\text{CPU power})$. T_A is the air approaching the heat exchanger.

The complete test matrix is summarized in the Table 6. The continuous operation tests were slightly accelerated to reduce duration for failure. The cracking mechanism #1 was accelerated significantly by running at $75\text{ }^\circ\text{C}$. The T_{LIQUID} value was achieved by applying a film heater to the bottom of the pump assembly alone (tubing and heat exchanger were not included by a closed loop tube was used to provide impedance from pump outlet to inlet).

Table 6. The Reliability Test Matrix

Use Condition	Test Conditions	Pump Speed	Included Failure Mechanisms
Continuous operation	$T_{LIQUID} = 50\text{ }^\circ\text{C}$	1450	2
	$T_{LIQUID} = 50\text{ }^\circ\text{C}$	1450	3, 4
	$T_{LIQUID} = 75\text{ }^\circ\text{C}$ for 16 weeks	1450	1
On-off cycles	$T_{LIQUID} = 35\text{-}60\text{ }^\circ\text{C}$, 7500 cycles	1450	1,2,3,4



5.2.3.1 Tubing Material Selection

Tubing material selection requires balancing several different criteria. The parameters that were considered were cost, flexibility, flammability and vapor transmissibility. Three different types of tubing materials were tested for liquid loss by connecting a know length of tubing to the ALCT pump and measuring the assembly weight prior to the start and periodically during the test to quantify the loss. The liquid evaporation and migration of vapor through the plastic walls to atmosphere is the mode of liquid loss that is affected by the internal structure of plastic and its wall thickness. The pumps were run at 1450 RPM and T_{LIQUID} was maintained at 50 °C. An extremely accurate scale is required to measure the weekly losses that allow for the calculation of a loss rate.

The results for 3 different materials are summarized in Table 7. The Norprene® tubing configuration had the lowest loss rate of 0.25 grams/week and was chosen as the tubing material for ALCT. Material parameters are 3/8" internal diameter and 5/8" outer diameter (1/8" wall thickness).

Table 7. The Weekly Loss Rate of Different Tubing Materials

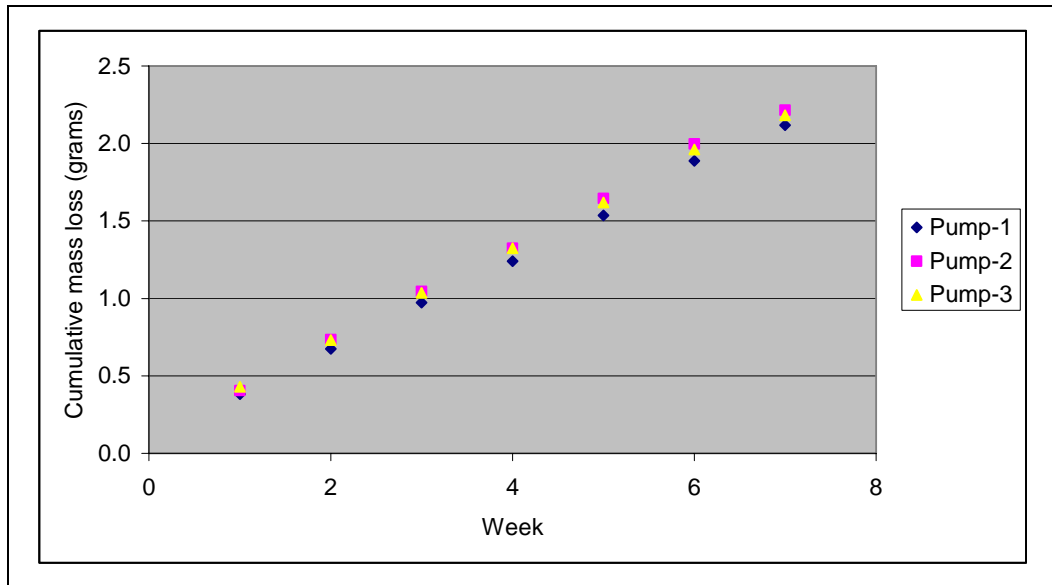
Tubing Material	Loss Rate (grams/week)
Polyurethene	5.0
PVC	1.2
Norprene®	0.25

5.2.3.2 Reservoir Sizing

The liquid loss through vapor migration through the tubing walls and joints can be minimized but not eliminated as shown by the relatively impermeable material of Norprene® rubber. The metal tubing was not a good option due to the flexibility needed for the assembly of the solution inside of a chassis. The effect of liquid loss can be mitigated at least for a reasonable operational life of the solution by providing a liquid reservoir. A continuous operation test at 50 °C and 1450 RPM was conducted with assembly mass monitored every week to identify weekly mass loss rate. The assembly mass loss data with 3 samples for 7 weeks duration is shown in Figure 13. The data shows that average loss rate was 0.25-0.30 grams/week and is reasonably consistent for 3 samples. The reservoir size of 38 milli-liters (38 grams for water) was chosen to provide 152 weeks (approximately 3 years) of operational life. The pump is expected to have additional resilience to liquid loss prior to significant impact to thermal performance.

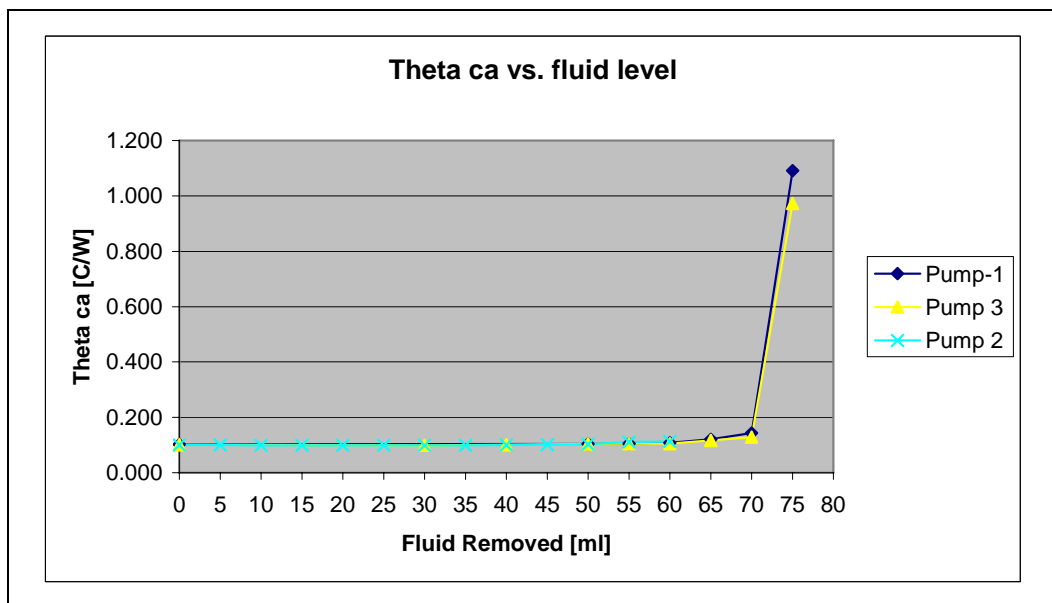


Figure 13. The Assembly Cumulative Mass Loss Data in Continuous Operation Test at 50 °C and 1450 RPM



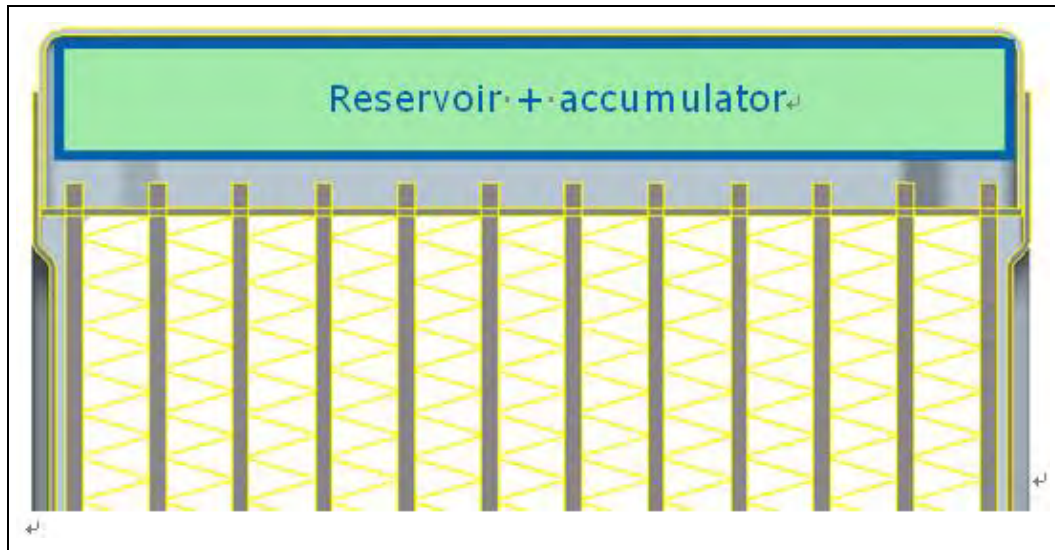
The reservoir presence in assembly and its impact on thermal performance was also confirmed by drawing the liquid out in the increment of 5 mL and measuring thermal performance at each increment. The Thermal resistance data are shown in Figure 14. It can be seen that when the liquid of 65 mL or more is drawn, thermal resistance goes up significantly. The test verifies the role of reservoir in maintaining thermal performance with liquid loss up to the reservoir size of 38 mL and 27 mL beyond that.

Figure 14. Thermal Resistance Curve for Liquid Loss of Reservoir



The reservoir is located in the heat exchanger at its top as shown in Figure 15. An air spring or an accumulator is needed to prevent high-pressure situation due to operating or storage temperature changes. 8 mL air volume is provided on the top of the reservoir to develop an air spring that minimizes the sensitivity to temperature change on pump internal pressure.

Figure 15. Reservoir Location



5.2.3.3 Reliability Test Results

The reliability test results are summarized in Table 8. A small sample size was used to evaluate design against reliability. Test results showed no assembly cracking failure in either continuous operation or on-off cycles. The liquid loss measured was smaller than the reservoir capability for either use condition. Thermal resistance showed change of -0.01 to $+0.007$ $^{\circ}\text{C}/\text{W}$ which is insignificant compared to the measurement accuracy of approximately ± 0.01 $^{\circ}\text{C}/\text{W}$. The pump motor and PCB also did not show significant RPM degradation. The pump internal mechanisms (e.g., corrosion) that affect thermal performance were not expected to be active with the cycling use condition only and so thermal performance after cycling test was not measured.



Table 8. Reliability Test Results

Use Condition	Test Conditions	Failure mechanism	Results
Continuous Operation	$T_{LIQUID} = 75\text{ }^{\circ}\text{C}$ for 16 weeks	1	0/10 failure
	$T_{LIQUID} = 50\text{ }^{\circ}\text{C}$	2	0.25-0.30 grams/week
	$T_{LIQUID} = 50\text{ }^{\circ}\text{C}$	3	Insignificant change in Ψ_{ca} for 3 samples
	$T_{LIQUID} = 50\text{ }^{\circ}\text{C}$	4	2% average RPM degradation after 8 weeks for 3 samples
On-off Cycles	$T_{LIQUID} = 35\text{-}60\text{ }^{\circ}\text{C}$, 5500 cycles	1	0/3 failure
	$T_{LIQUID} = 35\text{-}60\text{ }^{\circ}\text{C}$, 5500 cycles	2	3 grams loss after all cycles for 3 samples
	$T_{LIQUID} = 35\text{-}60\text{ }^{\circ}\text{C}$, 7500 cycles	4	No RPM degradation for 0/3 samples

5.2.4 Recommended BIOS/CPU/Memory Test Procedures

This test is to ensure proper operation of the product before and after environmental stresses, with the thermal mechanical enabling components assembled. The test shall be conducted on a fully operational motherboard that has not been exposed to any battery of tests prior to the test being considered.

Testing setup should include the following components, properly assembled and/or connected:

- Appropriate system motherboard
- Processor
- All enabling components, including socket and thermal solution parts
- Power supply
- Disk drive
- Video card
- DIMM
- Keyboard
- Monitor

The pass criterion is that the system under test shall successfully complete the checking of BIOS, basic processor functions and memory, without any errors.



5.3 Material and Recycling Requirements

Material shall be resistant to fungal growth. Examples of non-resistant materials include cellulose materials, animal and vegetable based adhesives, grease, oils, and many hydrocarbons. Synthetic materials such as PVC formulations, certain polyurethane compositions (e.g., polyester and some polyethers), plastics which contain organic fillers of laminating materials, paints, and varnishes also are susceptible to fungal growth. If materials are not fungal growth resistant, then MIL-STD-810E, Method 508.4 must be performed to determine material performance.

Material used shall not have deformation or degradation in a temperature life test.

Any plastic component exceeding 25 grams must be recyclable per the European Blue Angel recycling standards.

5.4 Safety Requirements

Heatsink and attachment assemblies shall be consistent with the manufacture of units that meet the safety standards:

- UL Recognition-approved for flammability at the system level. All mechanical and thermal enabling components must be a minimum UL94V-2 approved.
- CSA Certification. All mechanical and thermal enabling components must have CSA certification.
- All components (in particular the heatsink fins) must meet the test requirements of UL1439 for sharp edges.
- If the International Accessibility Probe specified in IEC 950 can access the moving parts of the fan, consider adding safety feature so that there is no risk of personal injury.

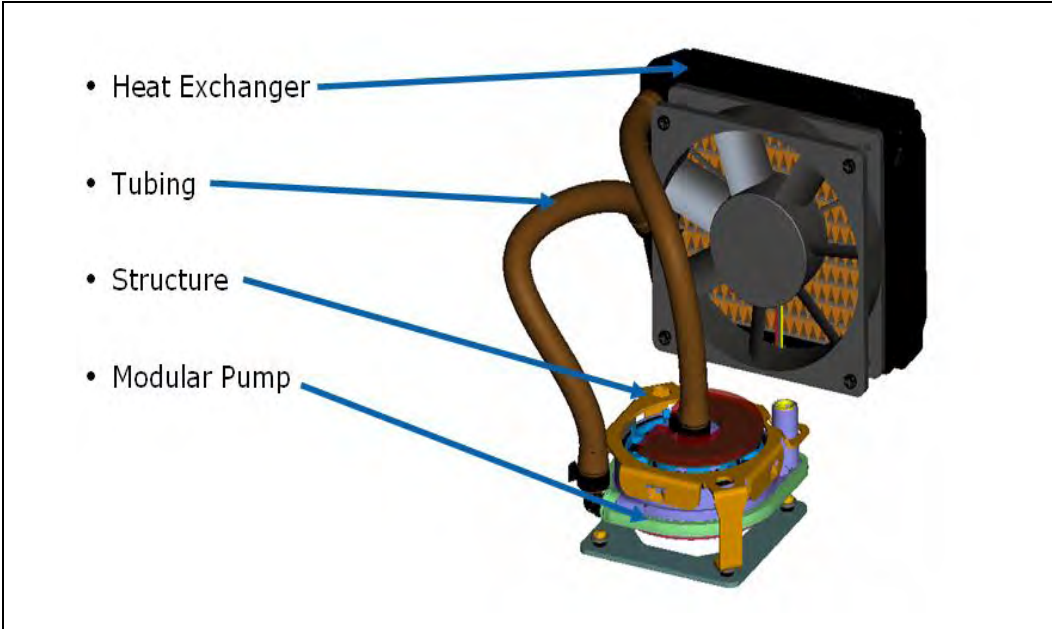
5.5 Geometric Envelope for Intel Reference ATX Thermal Mechanical Design

Figure 66, Figure 67, and Figure 68 in Appendix G gives detailed reference ATX/ μ ATX motherboard keep-out information for the reference thermal/mechanical enabling design. These drawings include height restrictions in the enabling component region.

The maximum height of the reference solution above the motherboard is 71.12 mm [2.8 inches] except for the flexible hoses which transit the area to the heat exchanger which is mounted on the back panel, and is compliant with the motherboard primary side height constraints defined in the *ATX Specification revision 2.2* and the *microATX Motherboard Interface Specification revision 1.2* found at <http://www.formfactors.org>. Figure 16 shows the Intel[®] ALCT Reference Design Major Components. The reference solution also requires suitable space to mount the heat exchanger fan combination on the back panel. Figure 17 gives the required foot print on the back panel.



Figure 16. Intel® ALCT Reference Design Major Components



Development vendor information for the Intel® ALCT Reference Solution is provided in Appendix A.

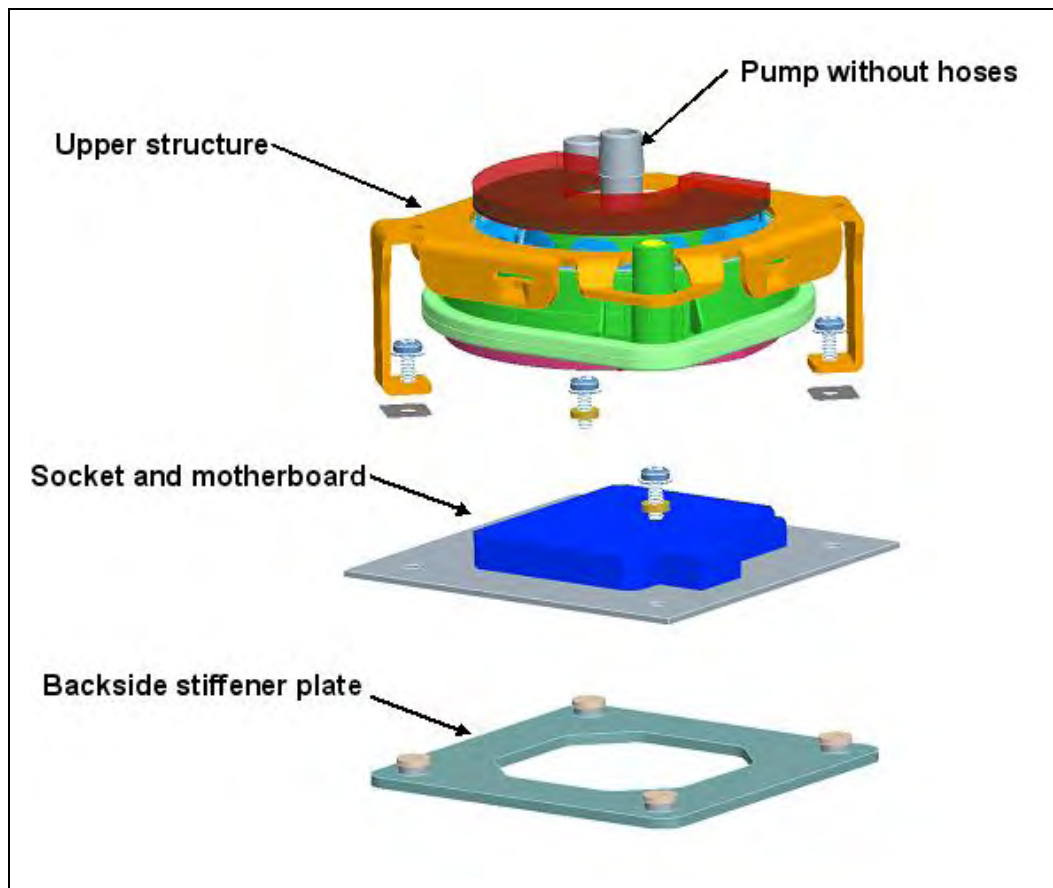
Figure 17. Heat Exchanger Fan Combination Foot Print View



5.6 Reference Attach Mechanism

The ALCT pump is attached to the motherboard through the use of a backside stiffener plate. Prior to motherboard installation in the chassis the backside stiffener plate is attached with two screws. Once installed these screws remain installed unless the stiffener plate requires removal. After installation of the board into the chassis the pump and upper structure are secured to the motherboard and backside stiffener with two additional screws (Figure 18). The heat exchanger is positioned on the back panel and is secured in place using four screws provided in the accessory kit. The heat exchanger can be mounted on most back panels that will accept 120 mm fans. The range of recommended positions of the heat exchanger relative to the pump is defined in Figure 74.

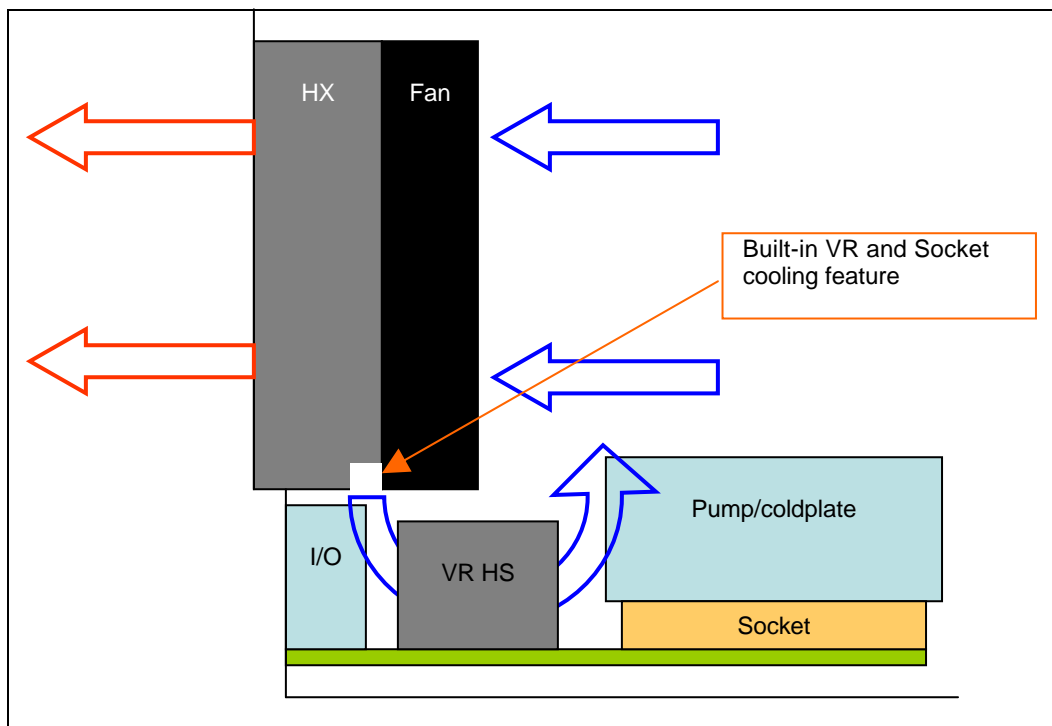
Figure 18. Structure to Motherboard Interface



5.7 Socket and Voltage Regulation Cooling Strategy

Consideration for the cooling of power delivery components and CPU socket needs to be addressed when using a remote heat exchanger. The use of a remote heat exchanger for processor cooling can remove the cooling air that the motherboard components around the socket need and traditionally get from an active heatsink directly attached to the processor IHS. The Intel ALCT Reference Design incorporates a voltage regulation and socket cooling scheme that eliminates the need for additional fan(s) on these components. The proximity of the remote heat exchanger on the rear panel of the ATX miniTower /Tower allows for direct impingement of airflow to the voltage regulation components. Figure 19 illustrates how a small gap or exit between the fan's pressure side and the heat exchanger inlet that is integrated into the heat exchanger design allows for air to be introduced directly to the VR region for cooling. This approach introduces an airflow path that doesn't significantly impact the airflow through the heat exchanger due to the reduced total impedance the fan sees and the subsequent increase in the operating point of the fan. Effectively the fan operating point increase is near the flow that is delivered to the VR and socket.

Figure 19. Diagram of Location of Heat Exchanger VR and Socket Airflow Cooling Feature



This method of VR and socket cooling was validated by testing this configuration as well as not having a gap. Analysis indicates that the momentum component attributed with the pressurized airflow in the configuration shown in Figure 19 would help the cooling flow penetrated the VR components down to the MB surface thus providing the best thermal performance.



Using the cooling approach on the Intel D975XBX2 Desktop Board the CPU current draw vs. heat exchanger fan speed is shown in Figure 20 and Table 9 as well as the performance of not having this cooling feature. This was measured as the maximum current draw before the VR circuitry reaches its maximum temperature and asserts the PROCHOT# signal.

The socket has a maximum temperature specification to maintain proper electrical performance at the contacts. Based on this temperature the current capability is slightly reduced but still shows improved capability of over 20 A at 100% speed over not having this feature.

Figure 20. CPU Maximum Current Draw for Heat Exchanger Fan Speed

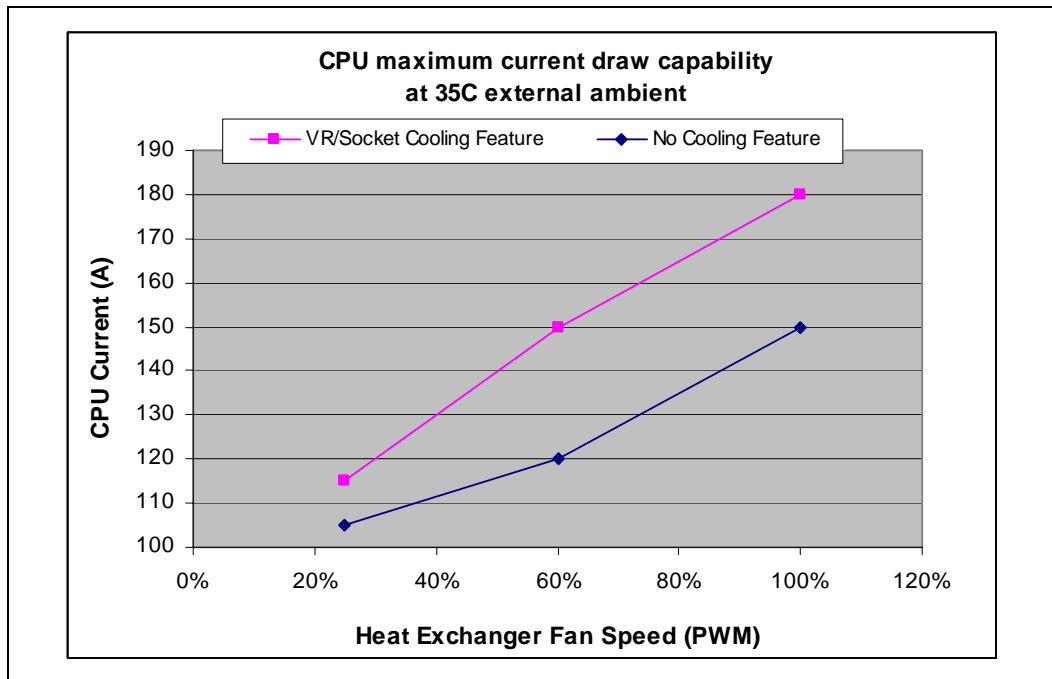


Table 9. Maximum Estimated Processor Current Capability at 35 °C External Ambient

Fan Speed (PWM)	Max. Current Draw for Heat Exchanger with VR and Socket Airflow Cooling Feature (A)	Max. Current Draw for Heat Exchanger and fan with no Cooling Feature (A)
25% – VR Requirements	115	105
60% – VR Requirements	150	120
100% – VR Requirements	180	150
100% – Socket Requirements ⁽¹⁾	165	140

NOTES:

1. Socket temperature requirement is based on the maximum temperature necessary for end of life socket electrical performance



6 Intel® Quiet System Technology (Intel® QST)

In the Intel® 965 Express Chipset Family a new control algorithm for fan speed control is being introduced. It is composed of a Manageability Engine (ME) in the Graphics Memory Controller Hub (GMCH) which executes the Intel® Quiet System Technology (Intel® QST) algorithm and the ICH8 containing the sensor bus and fan control circuits.

The ME provides integrated fan speed control in lieu of the mechanisms available in a SIO or a stand-alone ASIC. The Intel QST is time based as compared to the linear or state control used by the current generation of FSC devices.

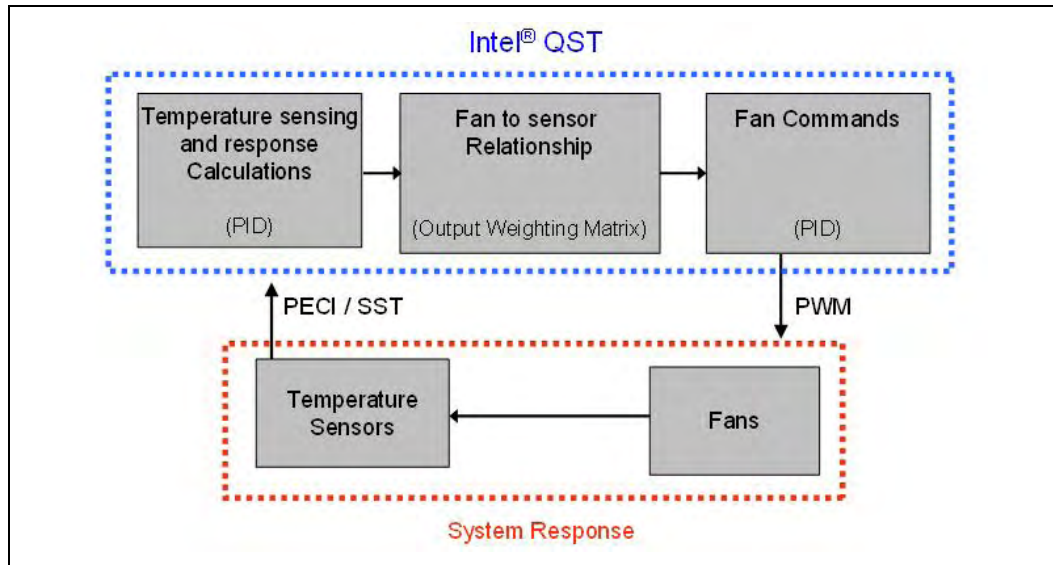
A short discussion of Intel QST will follow along with thermal solution design recommendations. For a complete discussion of programming the Intel QST in the ME please consult the *Intel® Quiet System Technology (Intel® QST) Configuration and Tuning Manual*.

6.1 Intel® Quiet System Technology Algorithm

The objective of Intel QST is to minimize the system acoustics by more closely controlling the thermal sensors to the corresponding processor or chipset device T_{CONTROL} value. This is achieved by the use of a Proportional-Integral-Derivative (PID) control algorithm and a Fan Output Weighting Matrix. The PID algorithm takes into account the difference between the current temperature and the target (T_{CONTROL}), the rate of change and direction of change to minimize the required fan speed change. The Fan Output Weighting Matrix utilizes the effects of each fan on a thermal sensor to minimize the required fan speed changes.

Figure 21 shows in a very simple manner how Intel QST works. See the *Intel® Quiet System Technology (Intel® QST) Configuration and Tuning Manual* for a detail discussion of the inputs and response.

Figure 21. Intel® Quiet System Technology Overview



6.1.1 Output Weighting Matrix

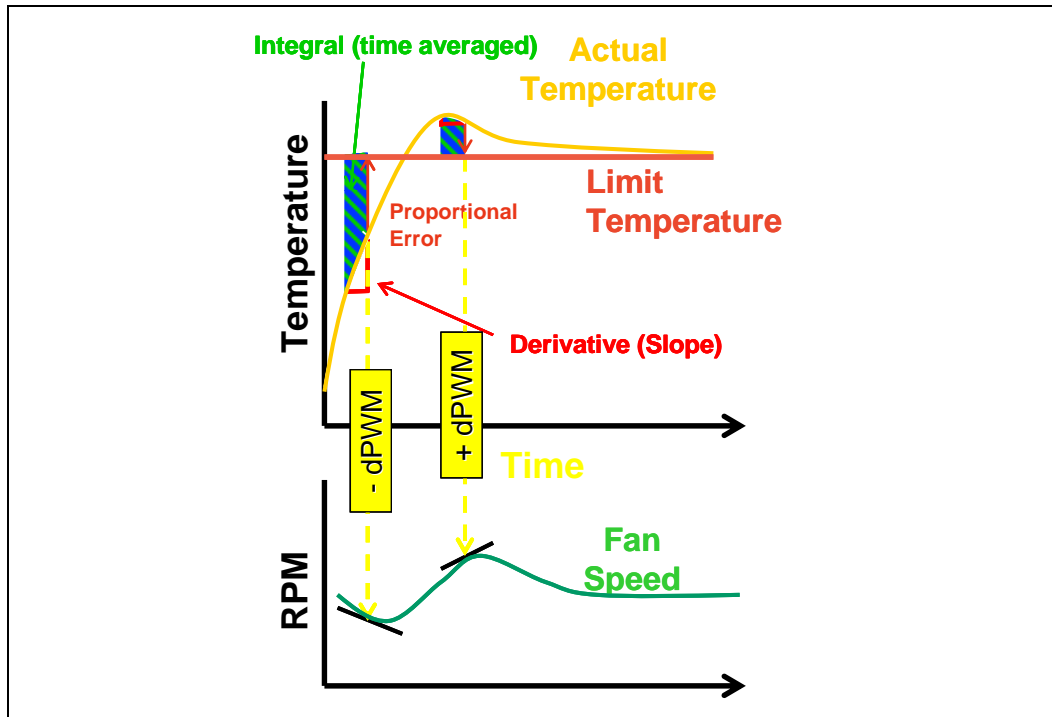
Intel QST provides an Output Weighting Matrix that provides a means for a single thermal sensor to affect the speed of multiple fans. An example of how the matrix could be used is if a sensor located next to the memory is sensitive to changes in both the processor heatsink fan and a 2nd fan in the system. By placing a factor in this matrix additional the Intel QST could command the processor thermal solution fan and this 2nd fan to both accelerate a small amount. At the system level these two small changes can result in a smaller change in acoustics than having a single fan respond to this sensor.

6.1.2 Proportional-Integral-Derivative (PID)

The use of Proportional-Integral-Derivative (PID) control algorithms allow the magnitude of fan response to be determined based upon the difference between current temperature readings and specific temperature targets. A major advantage of a PID Algorithm is the ability to control the fans to achieve sensor temperatures much closer to the $T_{CONTROL}$.

Figure 22 is an illustration of the PID fan control algorithm. As illustrated in the figure, when the actual temperature is below the target temperature, the fan will slow down. The current FSC devices have a fixed temperature vs. PWM output relationship and miss this opportunity to achieve additional acoustic benefits. As the actual temperature starts ramping up and approaches the target temperature, the algorithm will instruct the fan to speed up gradually, but will not abruptly increase the fan speed to respond to the condition. It can allow an overshoot over the target temperature for a short period of time while ramping up the fan to bring the actual temperature to the target temperature. As a result of its operation, the PID control algorithm can enable an acoustic-friendly platform.

Figure 22. PID Controller Fundamentals



For a PID algorithm to work limit temperatures are assigned for each temperature sensor. For Intel QST the T_{CONTROL} for the processor and chipset are to be used as the limit temperature. The ME will measure the error, slope and rate of change using the equations below:

- Proportional Error (P) = $T_{\text{LIMIT}} - T_{\text{ACTUAL}}$
- Integral (I) = Time averaged error
- Derivative (D) = $\Delta\text{Temp} / \Delta\text{Time}$

Three gain values are used to control response of algorithm.

- K_p = proportional gain
- K_i = Integral gain
- K_d = derivative gain

The *Intel® Quiet System Technology (Intel® QST) Configuration and Tuning Manual* provides initial values for the each of the gain constants. In addition it provides a methodology to tune these gain values based on system response.

Finally the fan speed change will be calculated using the following formula:

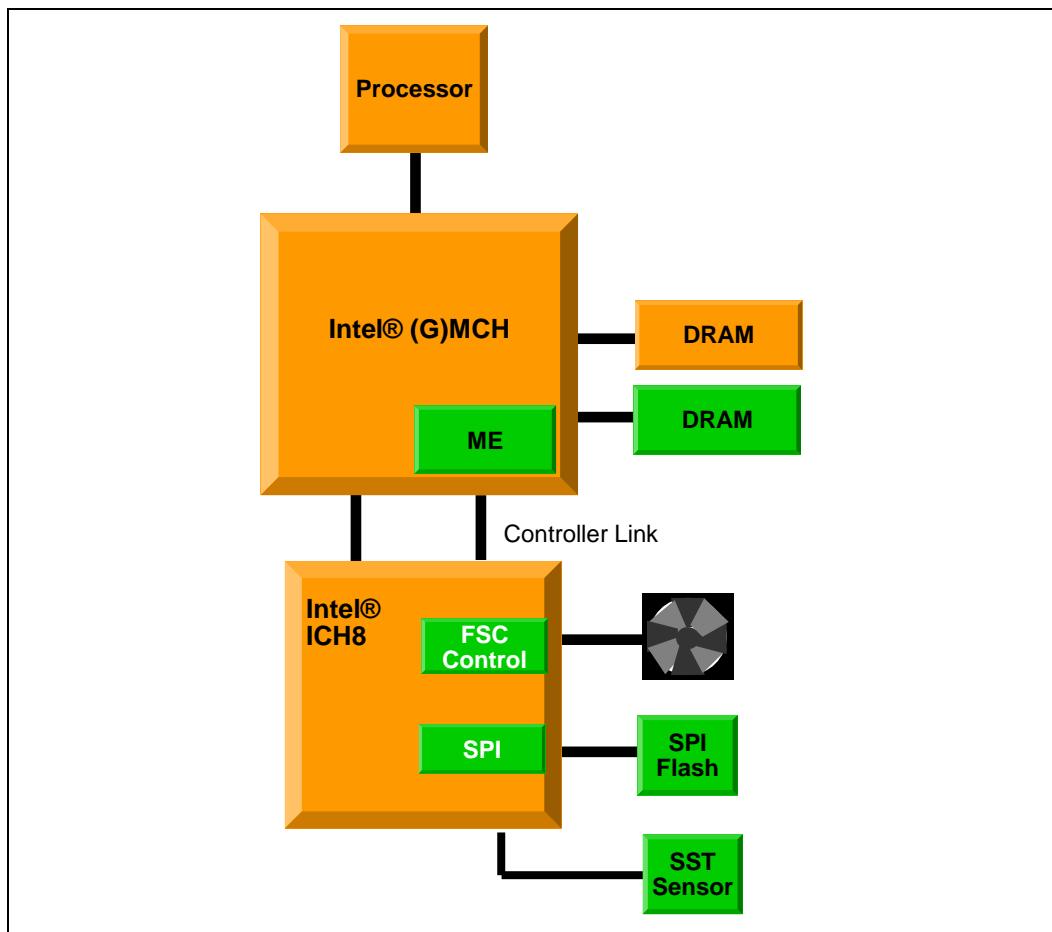
$$\Delta\text{PWM} = -P*(K_p) - I*(K_i) + D*(K_d)$$

6.2 Board and System Implementation of Intel® Quiet System Technology

To implement the board it must be configured as shown in Figure 23 and listed in the following bullets.

- ME system (S0-S1) with Controller Link connected and powered
- DRAM with Channel A DIMM 0 installed and 2 MB reserved for Intel QST FW execution
- SPI Flash with sufficient space for the Intel QST Firmware
- SST-based thermal sensors to provide board thermal data for Intel QST algorithms
- Intel QST firmware

Figure 23. Intel® Quiet System Technology Platform Requirements

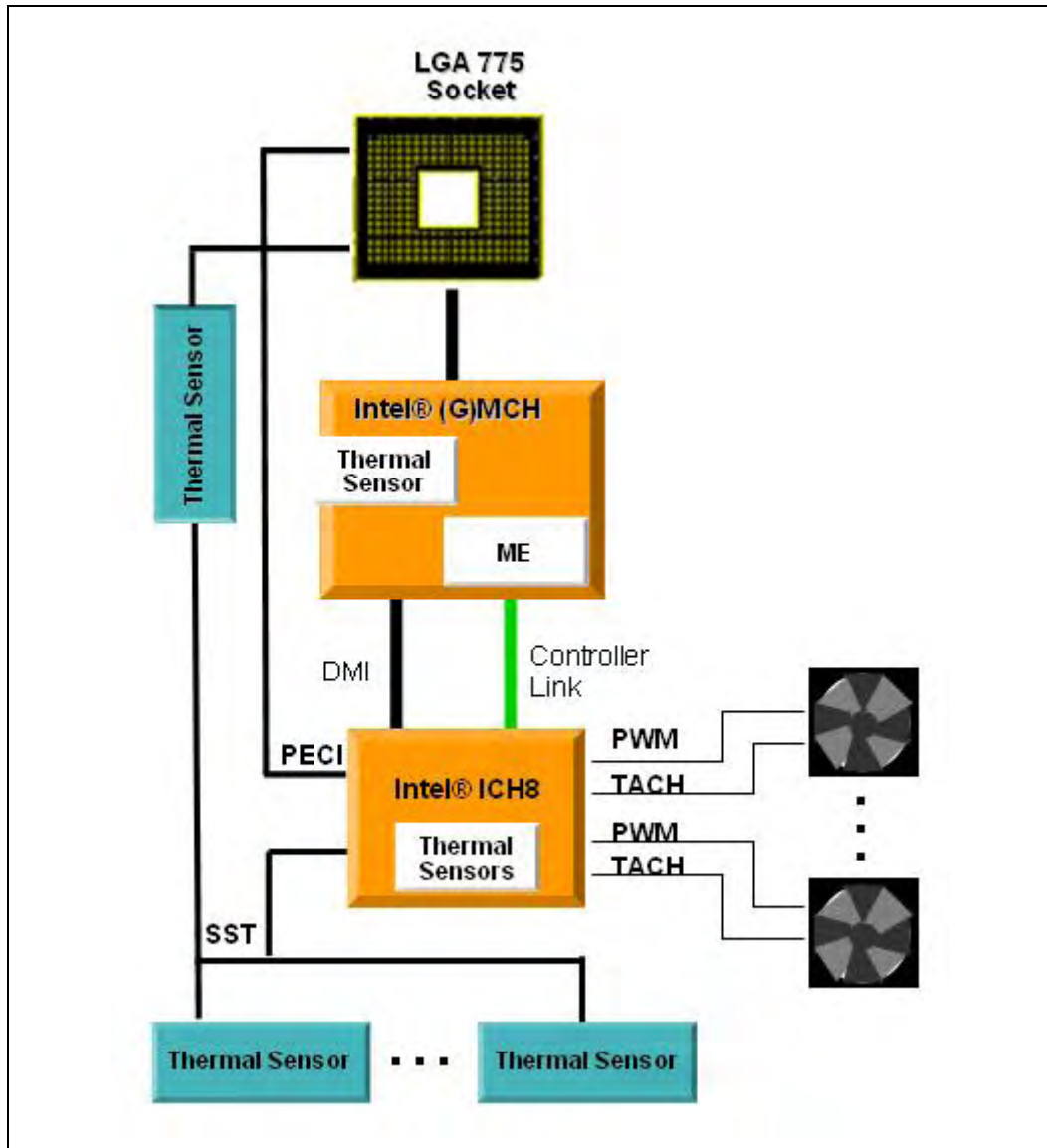


Note: Simple Serial Transport (SST) is a single wire bus that is included in the ICH8 to provide additional thermal and voltage sensing capability to the Manageability Engine (ME)



Figure 24 shows the major connections for a typical implementation that can support processors with digital thermal sensor or a thermal diode. In this configuration an SST Thermal Sensor has been added to read the on-die thermal diode that is in all of the processors in the 775-land LGA packages shipped before the Intel® Core™2 Duo processor. With the proper configuration information, the ME can accommodate inputs from PEIC or SST for the processor socket. Additional SST sensors can be added to monitor system thermal (see Appendix F for BTX recommendations for placement).

Figure 24. Example Acoustic Fan Speed Control Implementation



Intel has engaged with a number of major manufacturers of thermal / voltage sensors to provide devices for the SST bus. Contact your Intel Field Sales representative for the current list of manufacturers and visit their web sites or local sales representatives for a part suitable for your design.



6.3 Intel® QST Configuration & Tuning

Initial configuration of the Intel QST is the responsibility of the board manufacturer. The SPI flash should be programmed with the hardware configuration of the motherboard and initial settings for fan control, fan monitoring, voltage and thermal monitoring. This initial data is generated using the Intel provided Configuration Tool

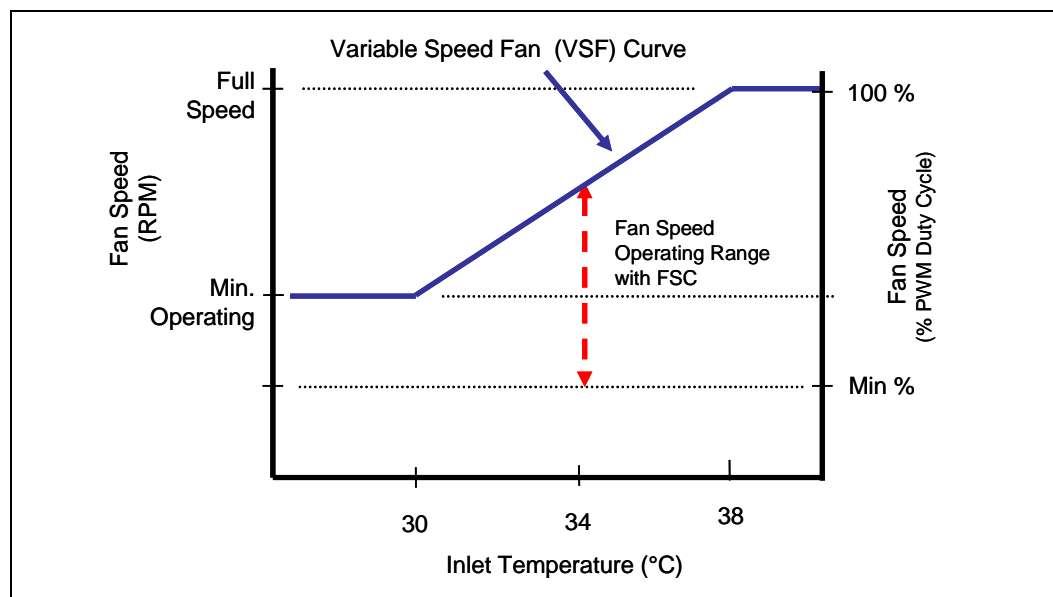
At the system integrator the Configuration Tool can be used again but this time to tune the Intel QST subsystem to reflect the shipping system configuration. In the tuning process the Intel QST can be modified to have the proper relationships between the installed fans and sensors in the shipping system. A Weighting Matrix Utility and Intel QST Log program are planned to assist in optimizing the fan management and achieve acoustic goal.

See your Intel field sales representative for availability of these tools.

6.4 Fan Hub Thermistor and Intel® QST

There is no closed loop control between Intel QST and the thermistor, but they can work in tandem to provide the maximum fan speed reduction. The BTX reference design includes a thermistor on the fan hub. This Variable Speed Fan curve will determine the maximum fan speed as a function of the inlet ambient temperature and by design provides a Ψ_{CA} sufficient to meet the thermal profile of the processor. Intel QST, by measuring the processor digital thermal sensor will command the fan to reduce speed below the VSF curve in response to processor workload. Conversely if the processor workload increases, the FSC will command the fan via the PWM duty cycle to accelerate the fan up to the limit imposed by the VSF curve. Care needs to be taken in BTX designs to ensure the fan speed at the minimum operating speed that sufficient air flow is being provided to support the other system components.

Figure 25. Digital Thermal Sensor and Thermistor



§



Appendix A LGA775 Socket Heatsink Loading

A.1 LGA775 Socket Heatsink Considerations

Heatsink clip load is traditionally used for:

- Mechanical performance in mechanical shock and vibration
 - Refer to Section 5.6 above for information on the structural design strategy for the Intel ALCT Reference Design
- Thermal interface performance
 - Required preload depends on TIM
 - Preload can be low for thermal grease

In addition to mechanical performance in shock and vibration and TIM performance, LGA775 socket requires a minimum heatsink preload to protect against fatigue failure of socket solder joints.

Solder ball tensile stress is originally created when, after inserting a processor into the socket, the LGA775 socket load plate is actuated. In addition, solder joint shear stress is caused by coefficient of thermal expansion (CTE) mismatch induced shear loading. The solder joint compressive axial force (F_{axial}) induced by the heatsink preload helps to reduce the combined joint tensile and shear stress.

Overall, the heatsink required preload is the minimum preload needed to meet all of the above requirements: Mechanical shock and vibration and TIM performance AND LGA775 socket protection against fatigue failure.



A.2 Metric for Heatsink Preload for ATX/μATX Designs Non-Compliant with Intel[®] Reference Design

A.2.1 Heatsink Preload Requirement Limitations

Heatsink preload by itself is not an appropriate metric for solder joint force across various mechanical designs and does not take into account for example (not an exhaustive list):

- Heatsink mounting hole span
- Heatsink clip assembly stiffness and creep
- Board stiffness and creep
- Board stiffness is modified by fixtures like backing plate, chassis attach, etc.

Simulation shows that the solder joint force (F_{axial}) is proportional to the board deflection measured along the socket diagonal. The matching of F_{axial} required to protect the LGA775 socket solder joint in temperature cycling is equivalent to matching a target MB deflection.

Therefore, the heatsink preload for LGA775 socket solder joint protection against fatigue failure can be more generally defined as the load required to create a target board downward deflection throughout the life of the product

This board deflection metric provides guidance for mechanical designs that differ from the reference design for ATX/μATX form factor.

A.2.2 Motherboard Deflection Metric Definition

Motherboard deflection is measured along either diagonal (refer to Figure 26):

$$d = d_{max} - (d1 + d2)/2$$

$$d' = d_{max} - (d'1 + d'2)/2$$

Configurations in which the deflection is measured are defined in the Table 10.

To measure board deflection, follow industry standard procedures (such as IPC) for board deflection measurement. Height gauges and possibly dial gauges may also be used.

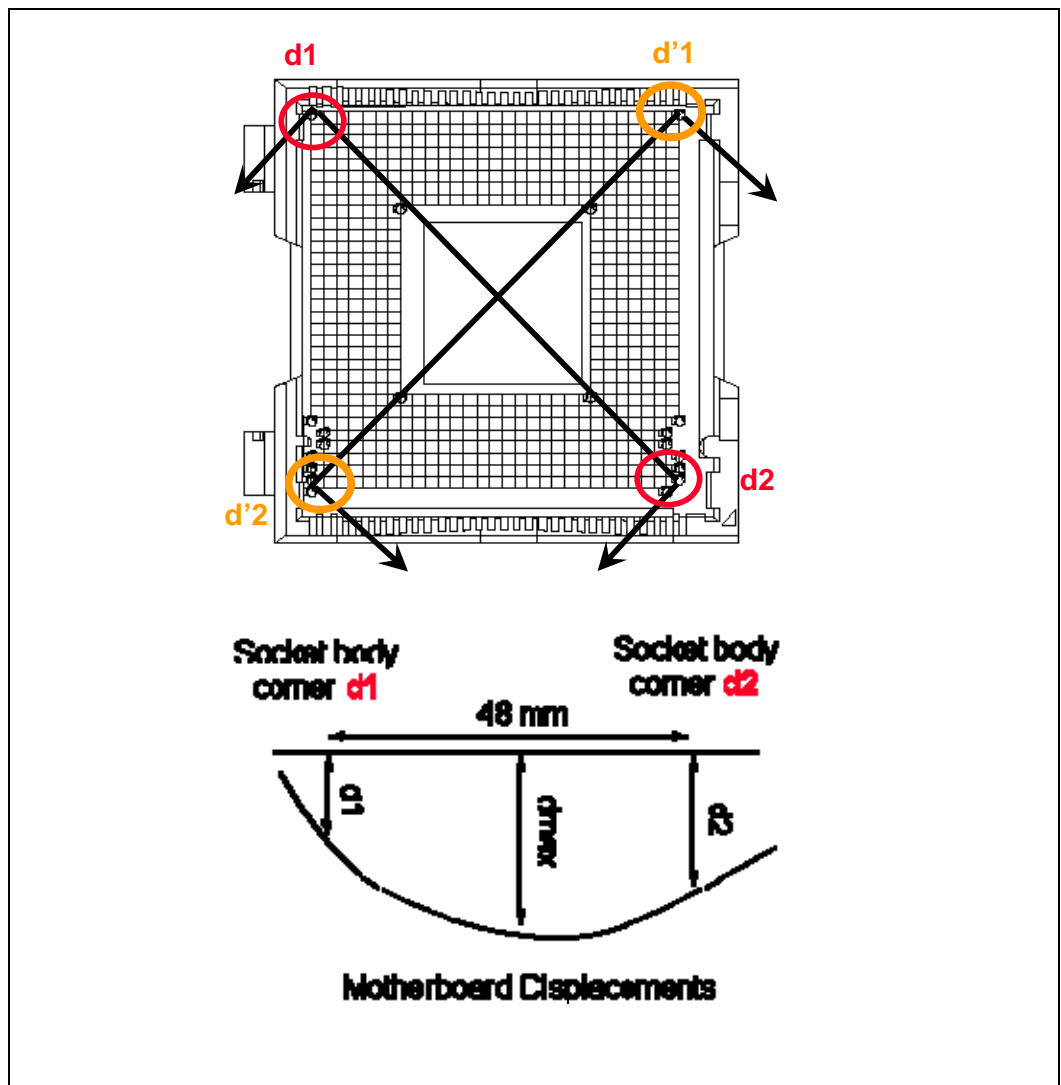


Table 10. Board Deflection Configuration Definitions

Configuration Parameter	Processor + Socket load plate	Heatsink	Parameter Name
d_ref	yes	no	BOL deflection, no preload
d_BOL	yes	yes	BOL deflection with preload
d_EOL	yes	yes	EOL deflection

BOL: Beginning of Life
 EOL: End of Life

Figure 26. Board Deflection Definition





A.2.3 Board Deflection Limits

Deflection limits for the ATX/ μ ATX form factor are:

$$d_{\text{BOL}} - d_{\text{ref}} \geq 0.09 \text{ mm} \quad \text{and} \quad d_{\text{EOL}} - d_{\text{ref}} \geq 0.15 \text{ mm}$$

And

$$d'_{\text{BOL}} - d'_{\text{ref}} \geq 0.09 \text{ mm} \quad \text{and} \quad d'_{\text{EOL}} - d'_{\text{ref}} \geq 0.15 \text{ mm}$$

NOTES:

1. The heatsink preload must remain within the static load limits defined in the processor datasheet at all times.
2. Board deflection should not exceed motherboard manufacturer specifications.

A.2.4 Board Deflection Metric Implementation Example

This section is for illustration only, and relies on the following assumptions:

- 72 mm x 72 mm hole pattern of the reference design
- Board stiffness = 900 lb/in at BOL, with degradation that simulates board creep over time
 - Though these values are representative, they may change with selected material and board manufacturing process. Check with your motherboard vendor.
- Clip stiffness assumed constant – No creep.

Using Figure 27, the heatsink preload at beginning of life is defined to comply with $d_{\text{EOL}} - d_{\text{ref}} = 0.15 \text{ mm}$ depending on clip stiffness assumption.

Note that the BOL and EOL preload and board deflection differ. This is a result of the creep phenomenon. The example accounts for the creep expected to occur in the motherboard. It assumes no creep to occur in the clip. However, there is a small amount of creep accounted for in the plastic fasteners. This situation is somewhat similar to the Intel Reference Design.

The impact of the creep to the board deflection is a function of the clip stiffness:

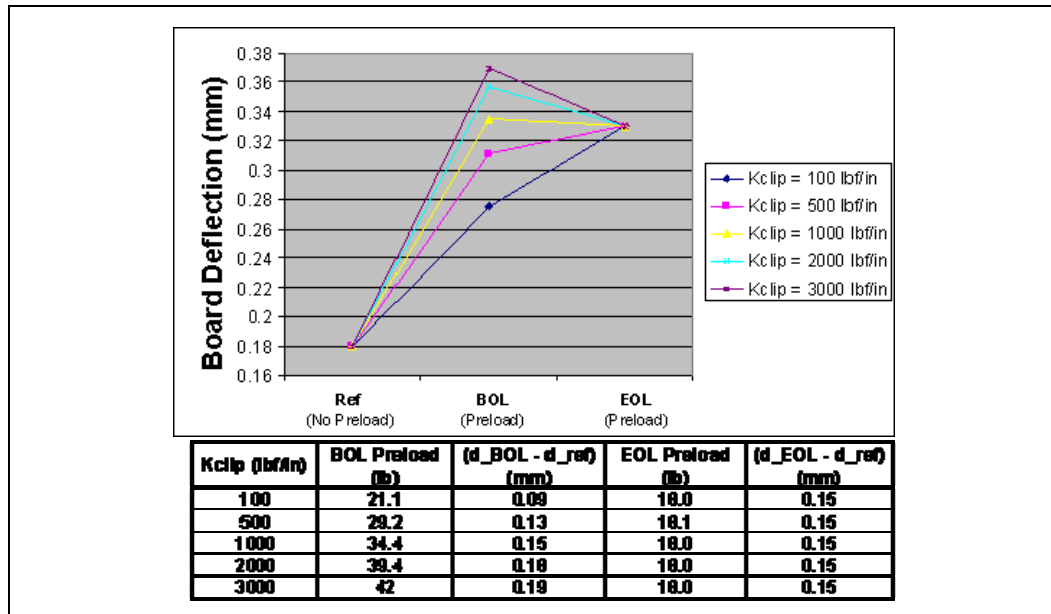
- The relatively compliant clips store strain energy in the clip under the BOL preload condition and tend to generate increasing amounts of board deflection as the motherboard creeps under exposure to time and temperature.
- In contrast, the stiffer clips store very little strain energy, and therefore does not generate substantial additional board deflection through life.

NOTES:

1. Board and clip creep modify board deflection over time and depends on board stiffness, clip stiffness, and selected materials.
2. Designers must define the BOL board deflection that will lead to the correct end of life board deflection



Figure 27. Example: Defining Heatsink Preload Meeting Board Deflection Limit



A.2.5 Additional Considerations

Intel recommends to design to $\{d_{BOL} - d_{ref} = 0.15 \text{ mm}\}$ at BOL when EOL conditions are not known or difficult to assess

The following information is given for illustration only. It is based on the reference keep-out, assuming there is no fixture that changes board stiffness:

d_{ref} is expected to be 0.18 mm on average, and be as high as 0.22 mm

As a result, the board should be able to deflect 0.37 mm minimum at BOL

Additional deflection as high as 0.09 mm may be necessary to account for additional creep effects impacting the board/clip assembly. As a result, designs could see as much as 0.50mm total downward board deflection under the socket.

In addition to board deflection, other elements need to be considered to define the space needed for the downward board total displacement under load, like the potential interference of through-hole mount component pin tails of the board with a mechanical fixture on the back of the board.

NOTES:

1. The heatsink preload must remain below the maximum load limit of the package at all times (Refer to processor datasheet)
2. Board deflection should not exceed motherboard manufacturer specifications.



A.2.5.1 Motherboard Stiffening Considerations

To protect LGA775 socket solder joint, designers need to drive their mechanical design to:

- Allow downward board deflection to put the socket balls in a desirable force state to protect against fatigue failure of socket solder joint (refer to sections A.2.1, A.2.2, and A.2.3.)
- Prevent board upward bending during mechanical shock event
- Define load paths that keep the dynamic load applied to the package within specifications published in the processor datasheet

Limiting board deflection may be appropriate in some situations like:

- Board bending during shock
- Board creep with high heatsink preload

However, the load required to meet the board deflection recommendation (refer to Section A.2.3) with a very stiff board may lead to heatsink preloads exceeding package maximum load specification. For example, such a situation may occur when using a backing plate that is flush with the board in the socket area, and prevents the board to bend underneath the socket.

A.3 Heatsink Selection Guidelines

Evaluate carefully heatsinks coming with motherboard stiffening devices (like backing plates), and conduct board deflection assessments based on the board deflection metric.

Solutions derived from the reference design comply with the reference heatsink preload, for example:

- The Intel ALCT reference design available from licensed suppliers (refer to Appendix H for contact information)

§



Appendix B Heatsink Clip Load Metrology

B.1 Overview

This section describes a procedure for measuring the load applied by the heatsink assembly on a processor package.

This procedure is recommended to verify the preload is within the design target range for a design, and in different situations. For example:

- Heatsink preload for the LGA775 socket
- Quantify preload degradation under bake conditions.

Note: This document reflects the current metrology used by Intel. Intel is continuously exploring new ways to improve metrology. Updates will be provided later as this document is revised as appropriate.

B.2 Test Preparation

B.2.1 Heatsink Preparation

Three load cells are assembled into the base of the heatsink under test, in the area interfacing with the processor Integrated Heat Spreader (IHS), using load cells equivalent to those listed in Section B.2.2.

To install the load cells, machine a pocket in the heatsink base, as shown Figure 28 and Figure 29. The load cells should be distributed evenly, as close as possible to the pocket walls. Apply wax around the circumference of each load cell and the surface of the pocket around each cell to maintain the load cells in place during the heatsink installation on the processor and motherboard (Refer to Figure 29).

The depth of the pocket depends on the height of the load cell used for the test. It is necessary that the load cells protrude out of the heatsink base. However, this protrusion should be kept minimal, as it will create additional load by artificially raising the heatsink base. The measurement offset depends on the whole assembly stiffness (i.e. motherboard, clip, etc.). Figure 30 shows an example using the Heatsink.

Note: When optimizing the heatsink pocket depth, the variation of the load cell height should also be taken into account to make sure that all load cells protrude equally from the heatsink base. It may be useful to screen the load cells prior to installation to minimize variation.

Remarks: Alternate Heatsink Sample Preparation

As mentioned above, making sure that the load cells have minimum protrusion out of the heatsink base is paramount to meaningful results. An alternate method to make sure that the test setup will measure loads representative of the non-modified design is:

- Machine the pocket in the heat sink base to a depth such that the tips of the load cells are just flush with the heat sink base
- Then machine back the heatsink base by around 0.25 mm [0.01"], so that the load cell tips protrude beyond the base.

Proceeding this way, the original stack height of the heatsink assembly should be preserved. This should not affect the stiffness of the heatsink significantly.

Figure 28. Load Cell Installation in Machined Heatsink Base Pocket – Bottom View

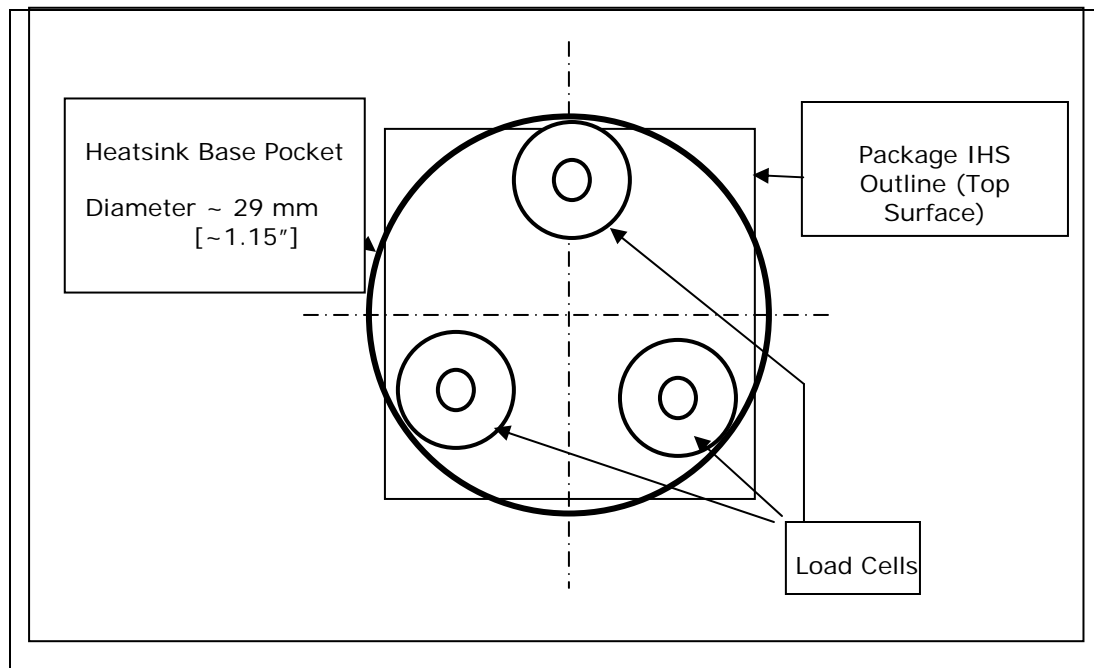




Figure 29. Load Cell Installation in Machined Heatsink Base Pocket – Side View

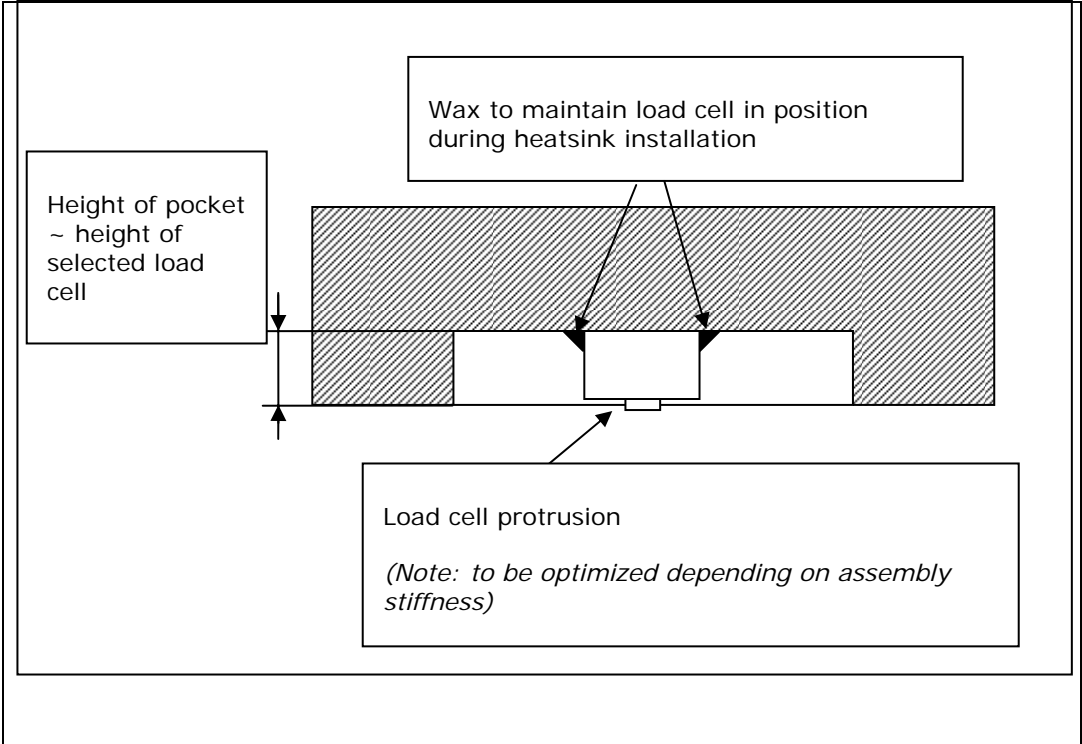
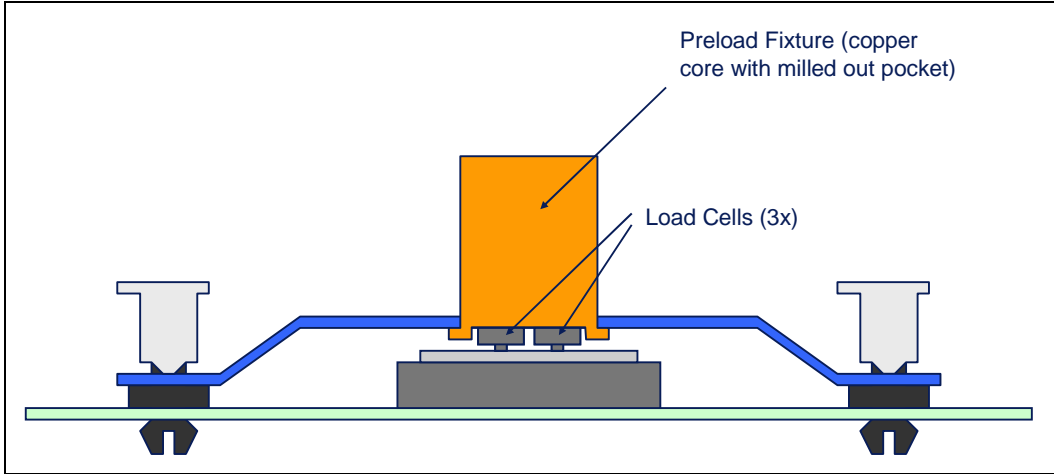


Figure 30. Preload Test Configuration





B.2.2 Typical Test Equipment

For the heatsink clip load measurement, use equivalent test equipment to the one listed Table 11.

Table 11. Typical Test Equipment

Item	Description	Part Number (Model)
	Honeywell*-Sensotec* Model 13 subminiature load cells, compression only. Select a load range depending on load level being tested. www.sensotec.com	AL32 2BL
	Vishay* Measurements Group Model 6100 scanner with a 6010A strain card (one card required per channel).	Model 6100

NOTES:

1. Select load range depending on expected load level. It is usually better, whenever possible, to operate in the high end of the load cell capability. Check with your load cell vendor for further information.
2. Since the load cells are calibrated in terms of mV/V, a data logger or scanner is required to supply 5 volts DC excitation and read the mV response. An automated model will take the sensitivity calibration of the load cells and convert the mV output into pounds.
3. With the test equipment listed above, it is possible to automate data recording and control with a 6101-PCI card (GPIB) added to the scanner, allowing it to be connected to a PC running LabVIEW* or Vishay's StrainSmart* software.
4. **IMPORTANT:** In addition to just a zeroing of the force reading at no applied load, it is important to calibrate the load cells against known loads. Load cells tend to drift. Contact your load cell vendor for calibration tools and procedure information.
5. When measuring loads under thermal stress (bake for example), load cell thermal capability must be checked, and the test setup must integrate any hardware used along with the load cell. For example, the Model 13 load cells are temperature compensated up to 71°C, as long as the compensation package (spliced into the load cell's wiring) is also placed in the temperature chamber. The load cells can handle up to 121°C (operating), but their uncertainty increases according to 0.02% rdg/°F.

B.3 Test Procedure Examples

The following sections give two examples of load measurement. However, this is not meant to be used in mechanical shock and vibration testing.

Any mechanical device used along with the heatsink attach mechanism will need to be included in the test setup (i.e., back plate, attach to chassis, etc.).

Prior to any test, make sure that the load cell has been calibrated against known loads, following load cell vendor's instructions.



B.3.1 Time-Zero, Room Temperature Preload Measurement

1. Pre-assemble mechanical components on the board as needed prior to mounting the motherboard on an appropriate support fixture that replicate the board attach to a target chassis
 - For example: standard ATX board should sit on ATX compliant stand-offs. If the attach mechanism includes fixtures on the back side of the board, those must be included, as the goal of the test is to measure the load provided by the actual heatsink mechanism.
2. Install relevant test vehicle (TTV, processor) in the socket
3. Assemble the heatsink reworked with the load cells to motherboard as shown for the heatsink example in Figure 30, and actuate attach mechanism.
4. Collect continuous load cell data at 1 Hz for the duration of the test. A minimum time to allow the load cell to settle is generally specified by the load vendors (often of order of 3 minutes). The time zero reading should be taken at the end of this settling time.
5. Record the preload measurement (total from all three load cells) at the target time and average the values over 10 seconds around this target time as well, i.e. in the interval , for example over [target time – 5 seconds ; target time + 5 seconds].

B.3.2 Preload Degradation under Bake Conditions

This section describes an example of testing for potential clip load degradation under bake conditions.

1. Preheat thermal chamber to target temperature (45 °C or 85 °C for example)
2. Repeat time-zero, room temperature preload measurement
3. Place unit into preheated thermal chamber for specified time
4. Record continuous load cell data as follows:
 - Sample rate = 0.1 Hz for first 3 hrs
 - Sample rate = 0.01 Hz for the remainder of the bake test
5. Remove assembly from thermal chamber and set into room temperature conditions
6. Record continuous load cell data for next 30 minutes at sample rate of 1 Hz.

§





Appendix C Thermal Interface Management

To optimize a heatsink design, it is important to understand the impact of factors related to the interface between the processor and the heatsink base. Specifically, the bond line thickness, interface material area and interface material thermal conductivity should be managed to realize the most effective thermal solution.

C.1 Bond Line Management

Any gap between the processor integrated heat spreader (IHS) and the heatsink base degrades thermal solution performance. The larger the gap between the two surfaces, the greater the thermal resistance. The thickness of the gap is determined by the flatness and roughness of both the heatsink base and the integrated heat spreader, plus the thickness of the thermal interface material (for example thermal grease) used between these two surfaces and the clamping force applied by the heatsink attach clip(s).

C.2 Interface Material Area

The size of the contact area between the processor and the heatsink base will impact the thermal resistance. There is, however, a point of diminishing returns. Unrestrained incremental increases in thermal interface material area do not translate to a measurable improvement in thermal performance.

C.3 Interface Material Performance

Two factors impact the performance of the interface material between the processor and the heatsink base:

- Thermal resistance of the material
- Wetting/filling characteristics of the material

Thermal resistance is a description of the ability of the thermal interface material to transfer heat from one surface to another. The higher the thermal resistance, the less efficient the interface material is at transferring heat. The thermal resistance of the interface material has a significant impact on the thermal performance of the overall thermal solution. The higher the thermal resistance, the larger the temperature drop is across the interface and the more efficient the thermal solution (heatsink, fan) must be to achieve the desired cooling.

The wetting or filling characteristic of the thermal interface material is its ability, under the load applied by the heatsink retention mechanism, to spread and fill the gap between the processor and the heatsink. Since air is an extremely poor thermal conductor, the more completely the interface material fills the gaps, the lower the temperature drops across the interface. In this case, thermal interface material area also becomes significant; the larger the desired thermal interface material area, the higher the force required to spread the thermal interface material.



§



Appendix D Case Temperature Reference Metrology

D.1 Objective and Scope

This appendix defines a reference procedure for attaching a thermocouple to the IHS of a 775-land LGA package for T_c measurement. This procedure takes into account the specific features of the 775-land LGA package and of the LGA775 socket for which it is intended. The recommended equipment for the reference thermocouple installation, including tools and part numbers are also provided.



D.2 Supporting Test Equipment

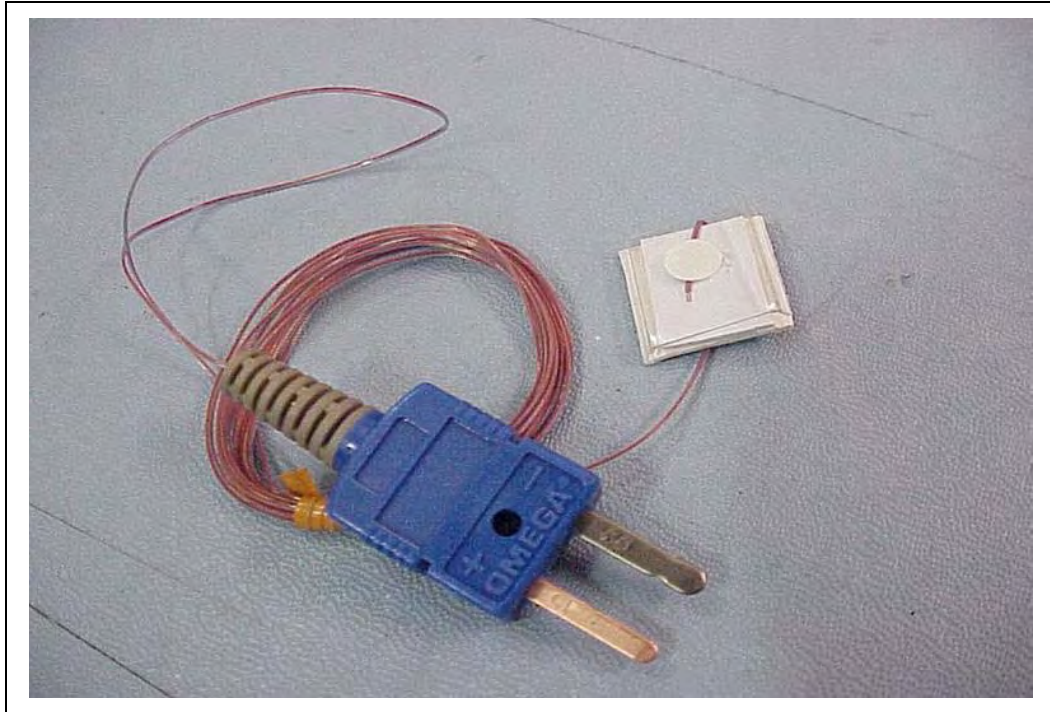
To apply the reference thermocouple attach procedure, it is recommended to use the equipment (or equivalent) given in the table below.

Item	Description	Part Number
Measurement and Output		
Microscope	Olympus* Light microscope or equivalent	SZ-40
DMM	Digital Multi Meter for resistance measurement	Fluke 79 Series
Thermal Meter	Hand held thermocouple meter	Multiple Vendors
Solder Station (see note 1 for ordering information)		
Heater Block	Heater assembly to reflow solder on IHS	30330
Heater	WATLOW120V 150W Firerod	0212G G1A38-L12
Transformer	Superior Powerstat transformer	05F857
Miscellaneous Hardware		
Solder	Indium Corp. of America Alloy 57BI / 42SN / 1AG 0.010 Diameter	52124
Flux	Indium Corp. of America	5RMA
Loctite* 498 Adhesive	Super glue w/thermal characteristics	49850
Adhesive Accelerator	Loctite* 7452 for fast glue curing	18490
Kapton* Tape	For holding thermocouple in place	Not Available
Thermocouple	Omega *,36 gauge, "T" Type (see note 2 for ordering information)	OSK2K1280/5SR TC-TT-T-36-72
Calibration and Control		
Ice Point Cell	Omega*, stable 0 °C temperature source for calibration and offset	TRCIII
Hot Point Cell	Omega *, temperature source to control and understand meter slope gain	CL950-A-110

NOTES:

1. The Solder Station consisting of the Heater Block, Heater, Press and Transformer are available from Jemelco Engineering 480-804-9514
2. This part number is a custom part with the specified insulation trimming and packaging requirements necessary for quality thermocouple attachment, See Figure 31. Order from Omega Anthony Alvarez, Direct phone (203) 359-7671, Direct fax (203) 968-7142, E-Mail: aalvarez@omega.com

Figure 31. Omega Thermocouple



D.3 Thermal Calibration and Controls

It is recommended that full and routine calibration of temperature measurement equipment be performed before attempting to perform case temperature measurements. Intel recommends checking the meter probe set against known standards. This should be done at 0 °C (using ice bath or other stable temperature source) and at an elevated temperature, around 80 °C (using an appropriate temperature source).

Wire gauge and length also should be considered as some less expensive measurement systems are heavily impacted by impedance. There are numerous resources available throughout the industry to assist with implementation of proper controls for thermal measurements.

NOTES:

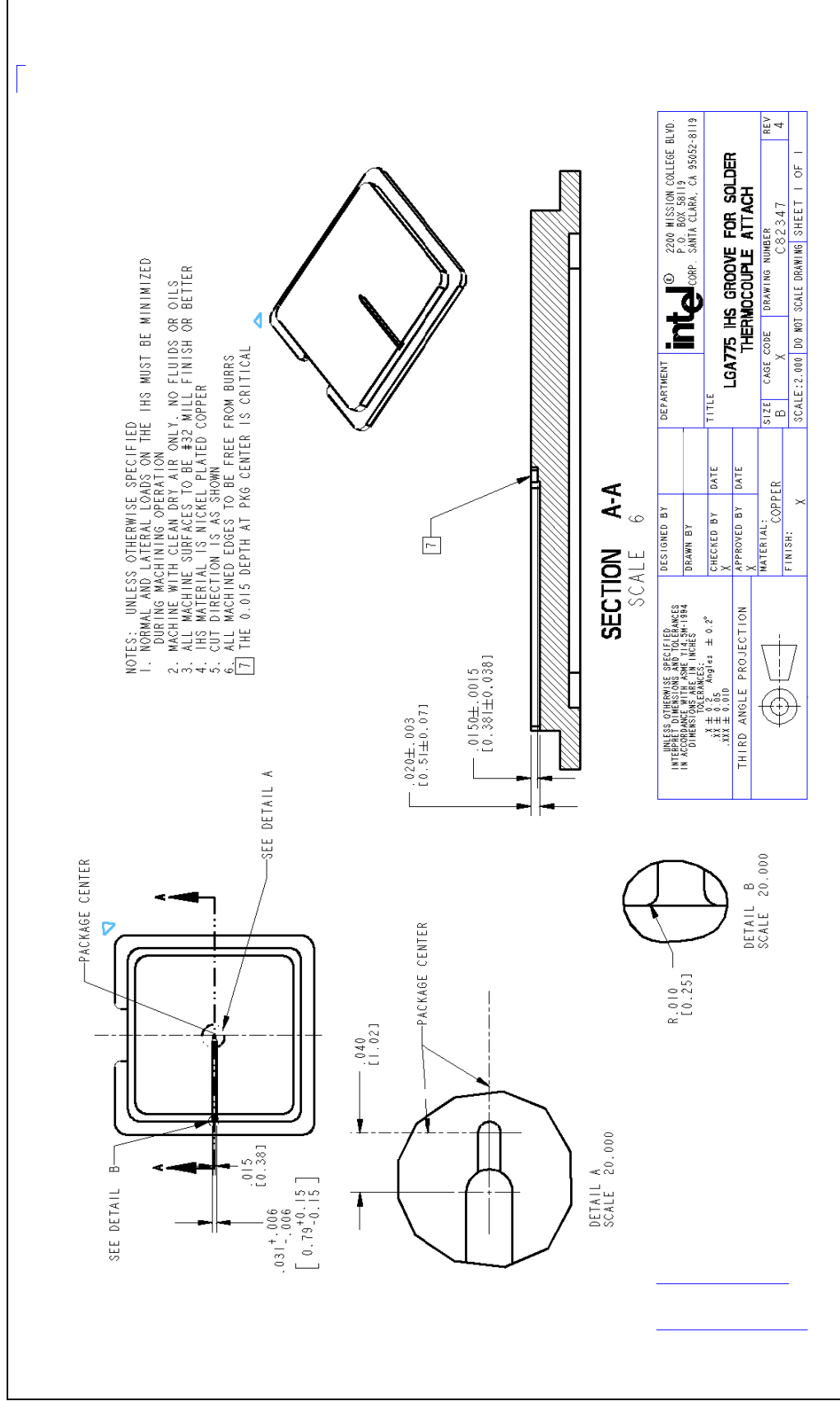
1. It is recommended to follow company standard procedures and wear safety items like glasses for cutting the IHS and gloves for chemical handling.
2. Ask your Intel field sales representative if you need assistance to groove and/or install a thermocouple according to the reference process.

D.4 IHS Groove

Cut a groove in the package IHS according to the drawing given in Figure 32.



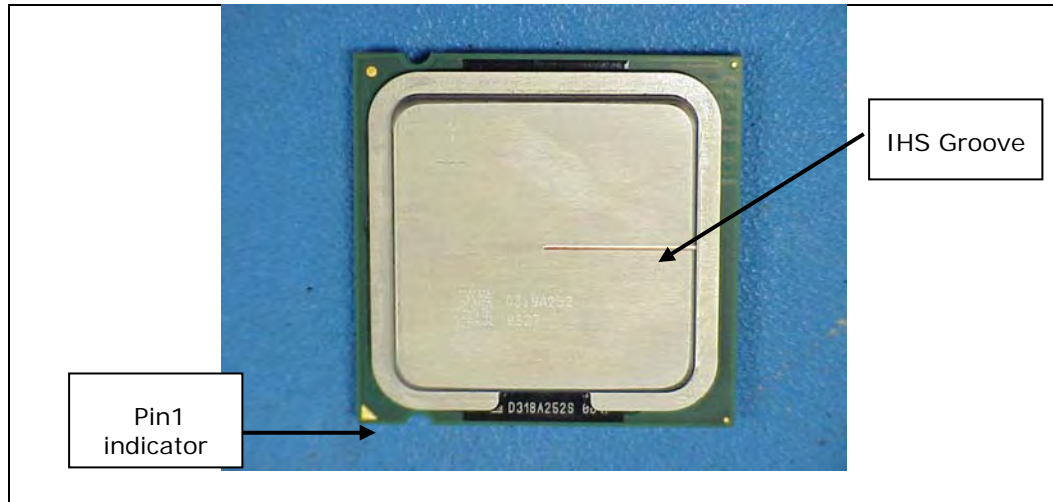
Figure 32. 775-LAND LGA Package Reference Groove Drawing





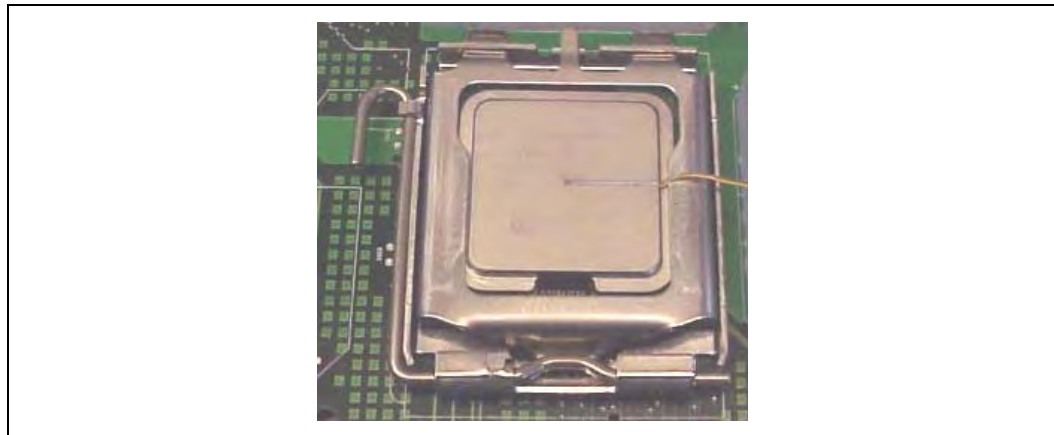
The orientation of the groove relative to the package pin 1 indicator (gold triangle in one corner of the package) is shown. Figure 33 for the 775-Land LGA package IHS.

Figure 33. IHS Groove on the 775-LAND LGA Package



When the processor is installed in the LGA775 socket, the groove is perpendicular to the socket load lever, and on the opposite side of the lever, as shown Figure 34.

Figure 34. IHS Groove Orientation Relative to the LGA775 Socket



Select a machine shop that is capable of holding drawing specified tolerances. IHS groove geometry is critical for repeatable placement of the thermocouple bead, ensuring precise thermal measurements. The specified dimensions minimize the impact of the groove on the IHS under the socket load. A larger groove may cause the IHS to warp under the socket load such that it does not represent the performance of an ungrooved IHS on production packages.

Inspect parts for compliance to specifications before accepting from machine shop.

D.5 Thermocouple Attach Procedure

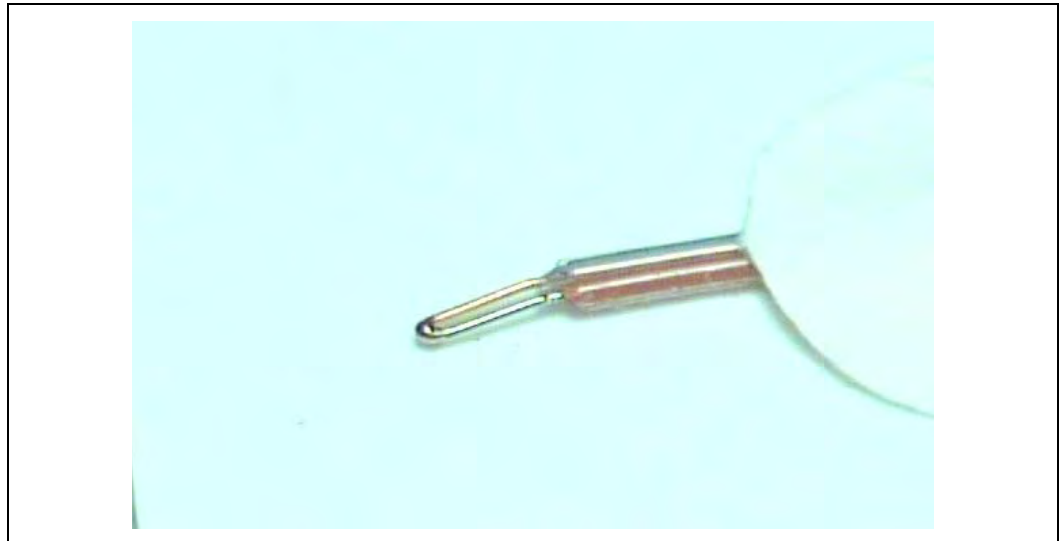
The procedure to attach a thermocouple with solder takes about 15 minutes to complete. Before proceeding turn on the solder block heater, as it can take up to 30 minutes to reach the target temperature of 153 – 155°C.

Note: To avoid damage to the TTV or processor ensure the IHS temperature does not exceed 155 °C.

D.5.1 Thermocouple Conditioning and Preparation

1. Use a calibrated thermocouple as specified in Sections D.2 and D.3.
2. Under a microscope verify the thermocouple insulation meets the quality requirements. The insulation should be about 1/16 inch (0.062 ± 0.030) from the end of the bead (Figure 35).

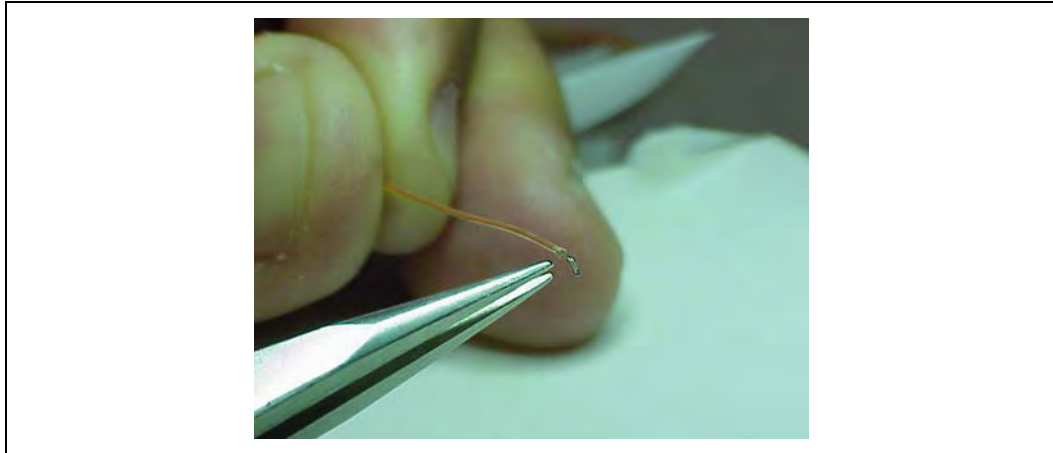
Figure 35. Inspection of Insulation on Thermocouple



3. Measure the thermocouple resistance by holding both contacts on the connector on one probe and the tip of thermocouple to the other probe of the DMM (measurement should be about ~3.0 ohms for 36-gauge type T thermocouple).
4. Straighten the wire for about 38 mm [1 ½ inch] from the bead.

5. Using the microscope and tweezers, bend the tip of the thermocouple at approximately 10 degree angle by about 0.8 mm [.030 inch] from the tip (Figure 36).

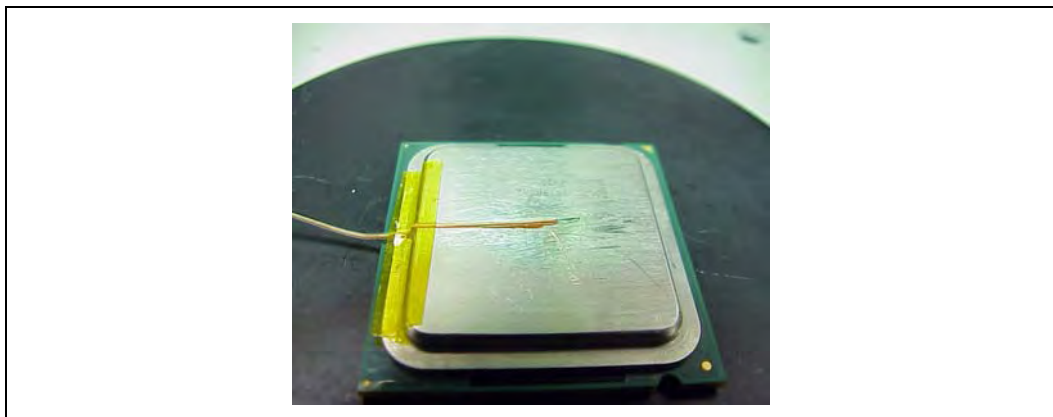
Figure 36. Bending the Tip of the Thermocouple



D.5.2 Thermocouple Attachment to the IHS

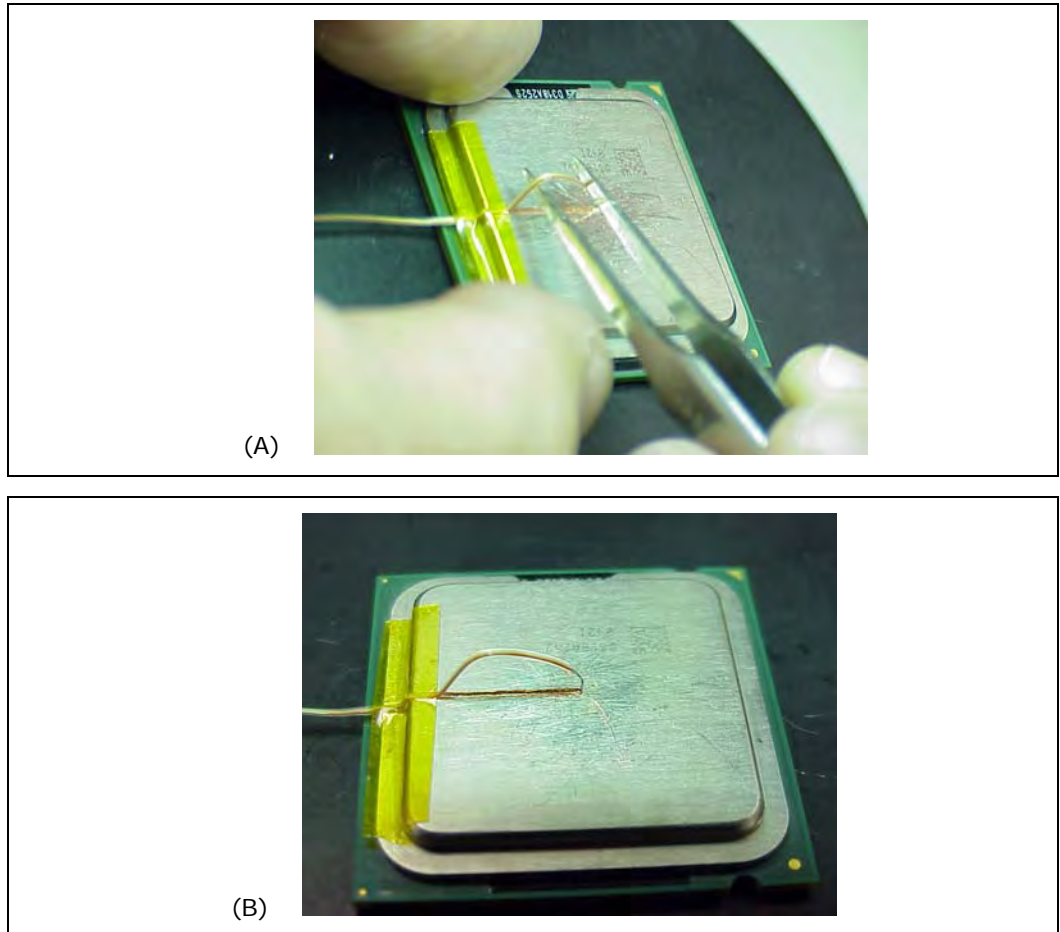
6. Clean groove and IHS with Isopropyl Alcohol (IPA) and a lint free cloth removing all residues prior to thermocouple attachment.
7. Place the thermocouple wire inside the groove; letting the exposed wire and bead extend about 1.5 mm [0.030 inch] past the end of groove. Secure it with Kapton* tape (Figure 37). Clean the IHS with a swab and IPA.
8. Verify under the microscope that the thermocouple wires are straight and parallel in the groove and that the bead is still bent.

Figure 37. Securing Thermocouple Wires with Kapton* Tape Prior to Attach



9. Lift the wire at the middle of groove with tweezers and bend the front of wire to place the thermocouple in the groove ensuring the tip is in contact with the end and bottom of the groove in the IHS (Figure 38-A and B).

Figure 38. Thermocouple Bead Placement



10. Place the package under the microscope to continue with process. It is also recommended to use a fixture (like processor tray or a plate) to help holding the unit in place for the rest of the attach process.

11. While still at the microscope, press the wire down about 6mm [0.125"] from the thermocouple bead using the tweezers or your finger. Place a piece of Kapton* tape to hold the wire inside the groove (Figure 39). Refer to Figure 40 for detailed bead placement.

Figure 39. Position Bead on the Groove Step

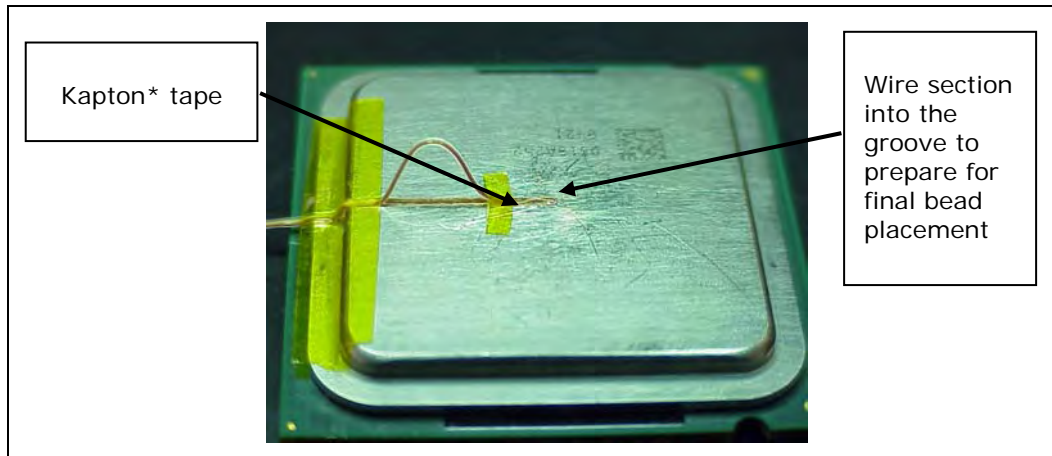


Figure 40. Detailed Thermocouple Bead Placement

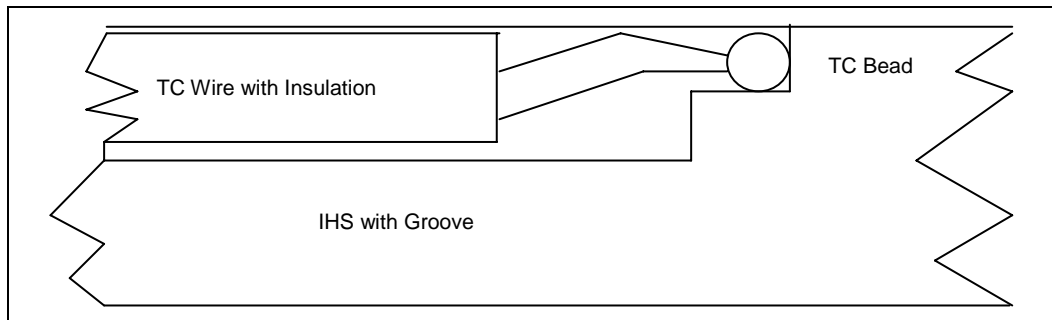
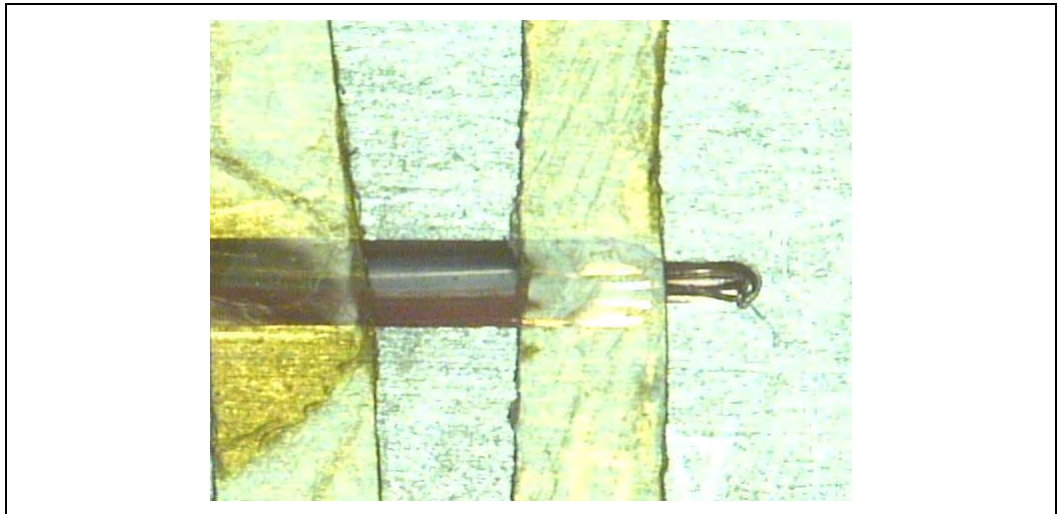
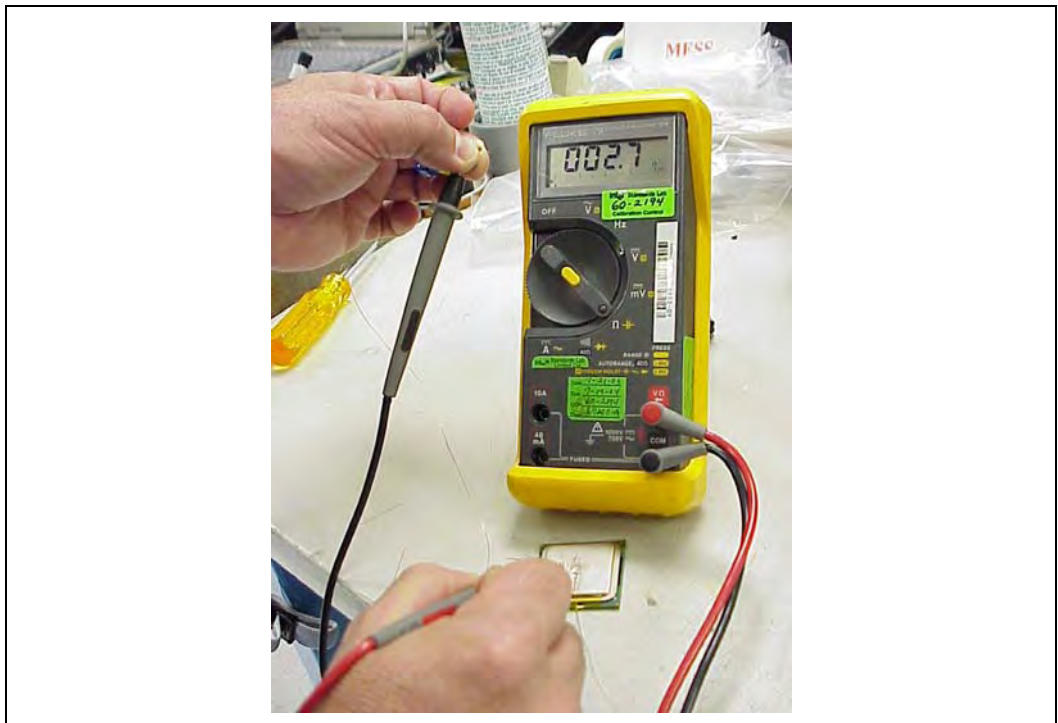


Figure 41. Third Tape Installation



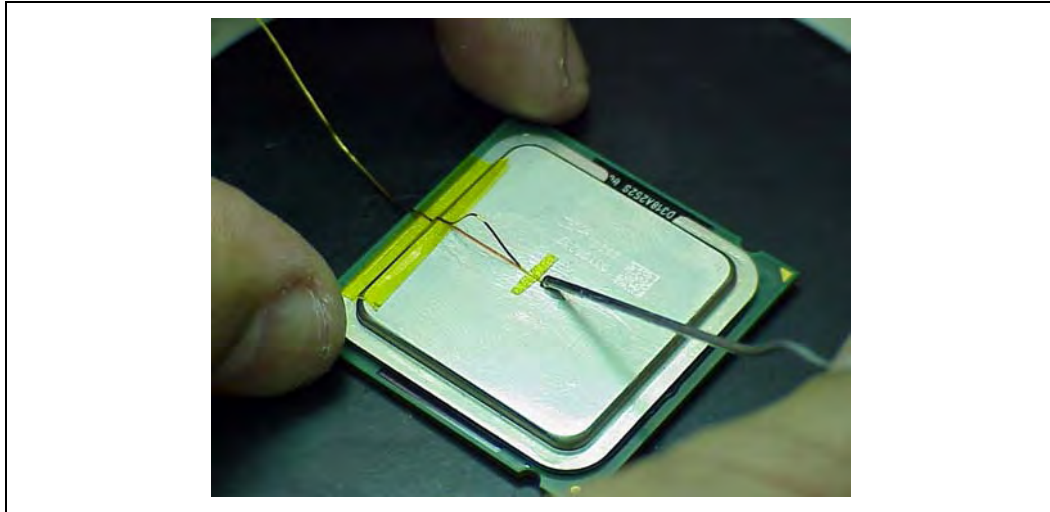
12. Place a 3rd piece of tape at the end of the step in the groove as shown in Figure 41. This tape will create a solder dam to prevent solder from flowing into the larger IHS groove section during the melting process.
13. Measure resistance from thermocouple end wires (hold both wires to a DMM probe) to the IHS surface. This should be the same value as measured during the thermocouple conditioning Section D.5.1, step 3 (Figure 42)

Figure 42. Measuring Resistance between Thermocouple and IHS



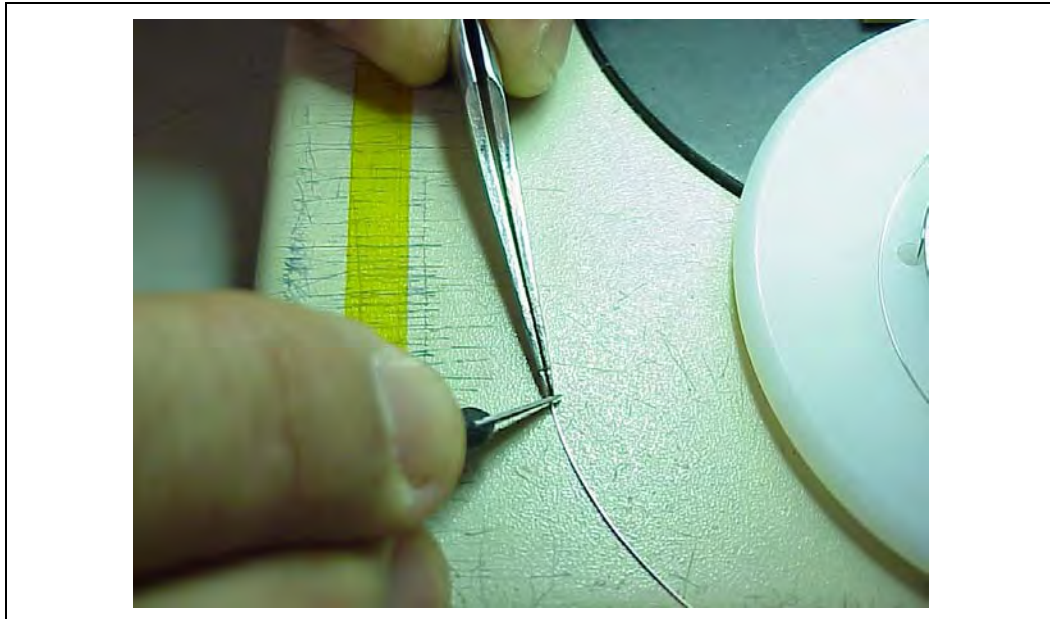
14. Using a fine point device, place a small amount of flux on the thermocouple bead. Be careful not to move the thermocouple bead during this step (Figure 43). Ensure the flux remains in the bead area only.

Figure 43. Applying Flux to the Thermocouple Bead



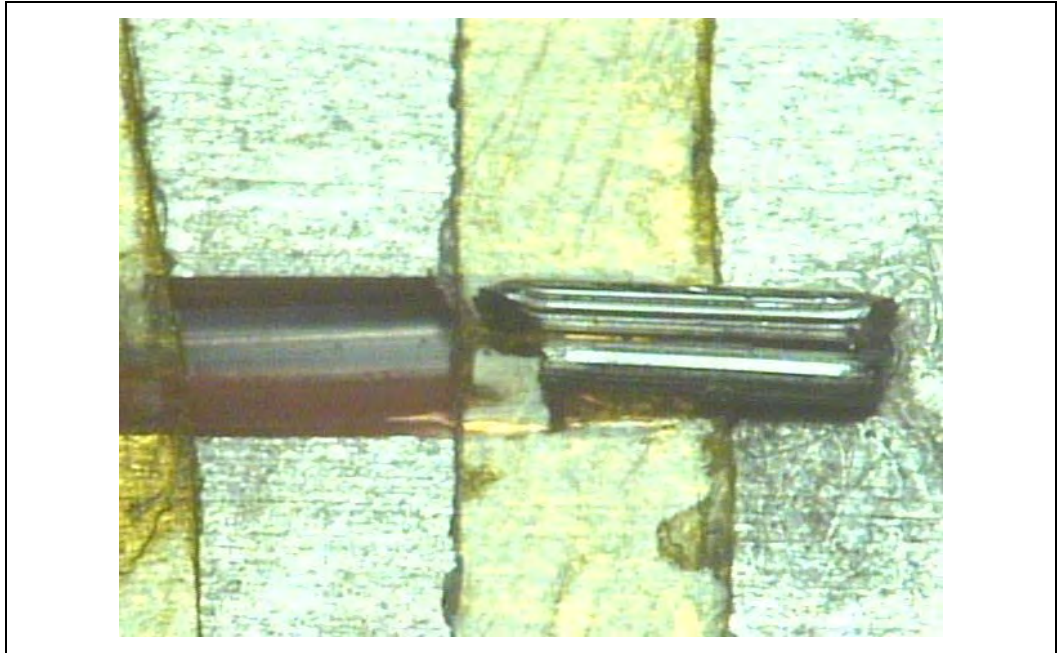
15. Cut two small pieces of solder 1/16 inch (0.065 inch / 1.5 mm) from the roll using tweezers to hold the solder while cutting with a fine blade (Figure 44)

Figure 44. Cutting Solder



16. Place the two pieces of solder in parallel, directly over the thermocouple bead (Figure 45)

Figure 45. Positioning Solder on IHS

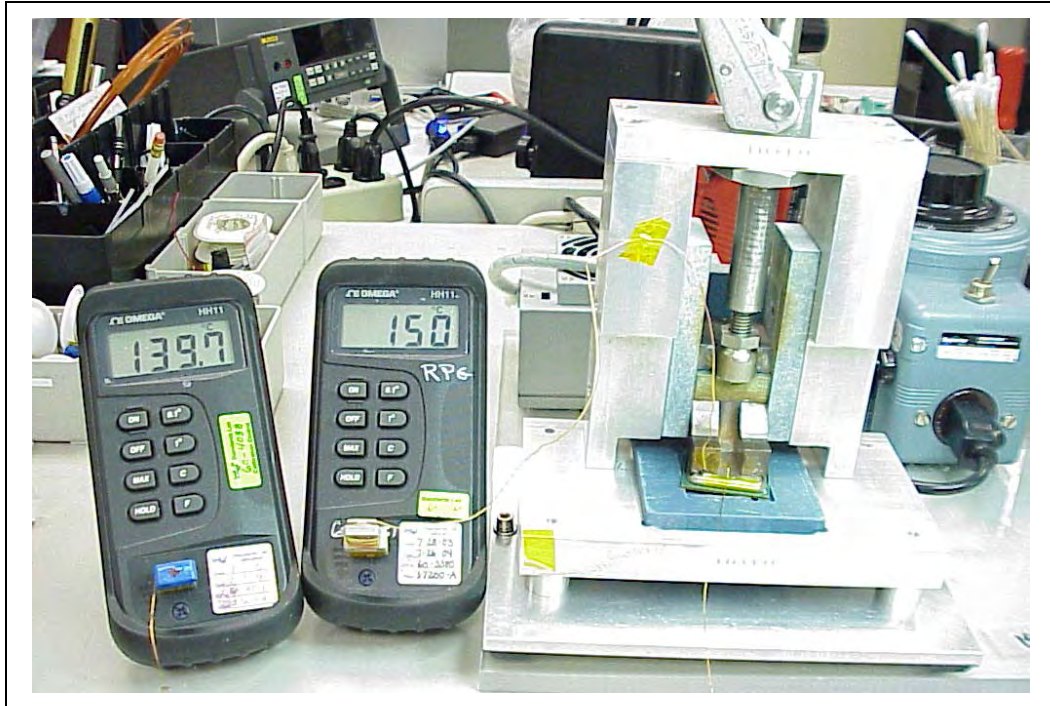


17. Measure the resistance from the thermocouple end wires again using the DMM (refer to Section D.5.1, step 2) to ensure the bead is still properly contacting the IHS.

D.5.3 Solder Process

18. Make sure the thermocouple that monitors the Solder Block temperature is positioned on the Heater block. Connect the thermocouple to a handheld meter to monitor the heater block temperature
19. Verify the temperature of the Heater block station has reached $155^{\circ}\text{C} \pm 5^{\circ}\text{C}$ before you proceed.
20. Connect the thermocouple for the device being soldered to a second hand held meter to monitor IHS temperature during the solder process.

Figure 46. Solder Station Setup



21. Remove the land side protective cover and place the device to be soldered in the solder station. Make sure the thermocouple wire for the device being soldered is exiting the heater toward you.

Note: Do not touch the copper heater block at any time as this is very hot.

22. Move a magnified lens light close to the device in the solder status to get a better view when the solder begins to melt.
23. Lower the Heater block onto the IHS. Monitor the device IHS temperature during this step to ensure the maximum IHS temperature is not exceeded

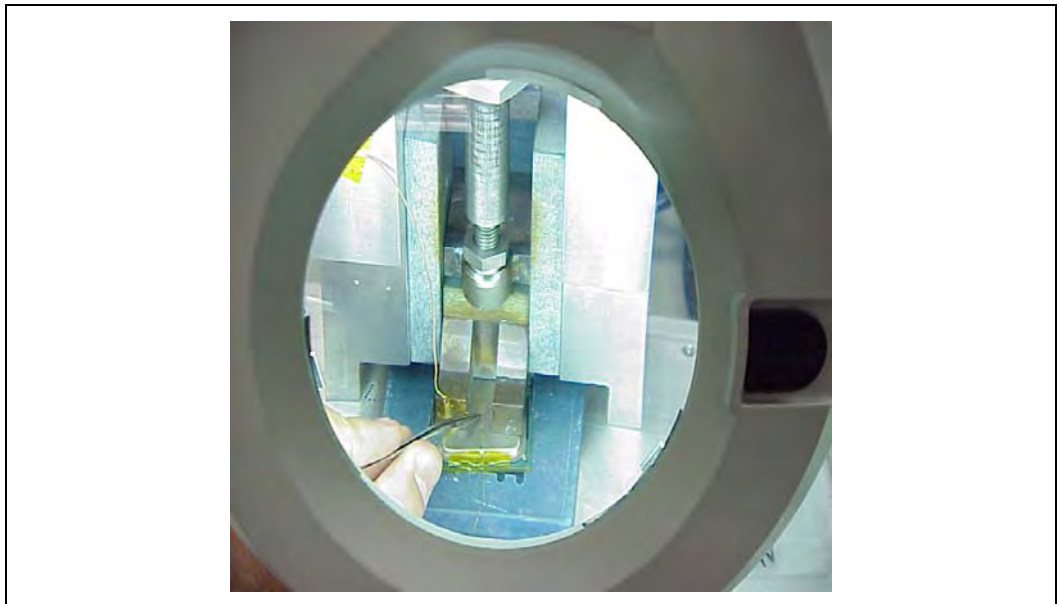
Note: The target IHS temperature during reflow is $150^{\circ}\text{C} \pm 3^{\circ}\text{C}$. At no time should the IHS temperature exceed 155°C during the solder process as damage to the device may occur.

24. You may need to move the solder back toward the groove as the IHS begins to heat. Use a fine tip tweezers to push the solder into the end of the groove until a solder ball is built up (Figure 47 and Figure 48)

Figure 47. View Through Lens at Solder Station

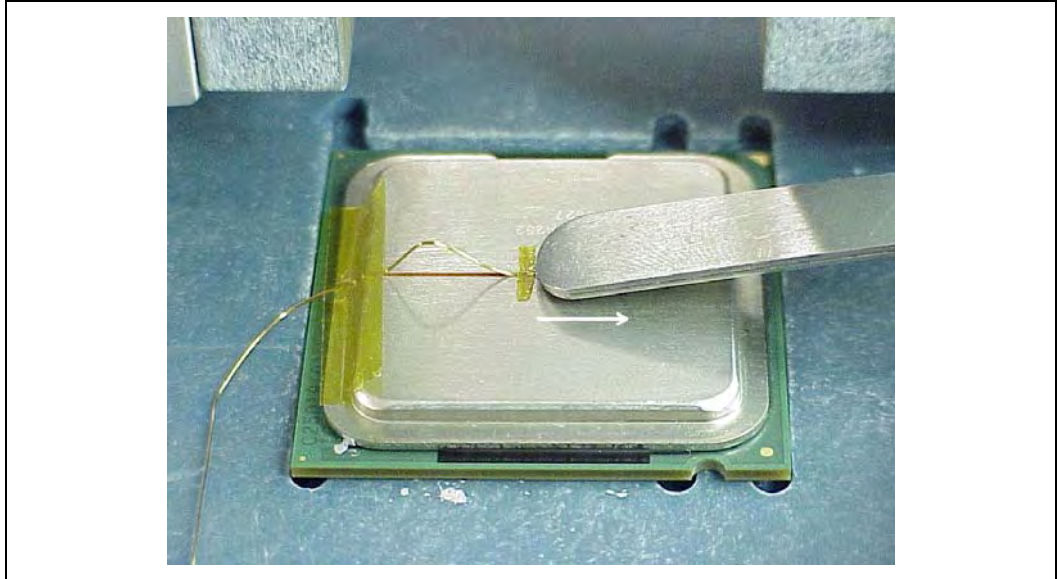


Figure 48. Moving Solder back onto Thermocouple Bead



25. Lift the heater block and magnified lens, using tweezers quickly rotate the device 90 degrees clockwise. Using the back of the tweezers press down on the solder this will force out the excess solder

Figure 49. Removing Excess Solder



26. Allow the device to cool down. Blowing compressed air on the device can accelerate the cooling time. Monitor the device IHS temperature with a handheld meter until it drops below 50° C before moving it to the microscope for the final steps

D.5.4 Cleaning and Completion of Thermocouple Installation

27. Remove the device from the solder station and continue to monitor IHS Temperature with a handheld meter. Place the device under the microscope and remove the three pieces of Kapton* tape with Tweezers, keeping the longest for re-use.
28. Straighten the wire and work the wire in to the groove. Bend the thermocouple over the IHS. Replace the long piece of Kapton* tape at the edge of the IHS.

Note: The wire needs to be straight so it doesn't sit above the IHS surface at anytime (Figure 50).

Figure 50. Thermocouple placed into groove



29. Using a blade carefully shave the excess solder above the IHS surface. Only shave in one direction until solder is flush with the groove surface (Figure 51).

Figure 51. Removing Excess Solder



Note: Take usual precautions when using open blades

30. Clean the surface of the IHS with Alcohol and use compressed air to remove any remaining contaminants.

31. Fill the rest of the groove with Loctite* 498 Adhesive. Verify under the microscope that the thermocouple wire is below the surface along the entire length of the IHS groove (Figure 52).

Figure 52. Filling Groove with Adhesive



32. To speed up the curing process apply Loctite* Accelerator on top of the Adhesive and let it set for a couple of minutes(Figure 53).

Figure 53. Application of Accelerant

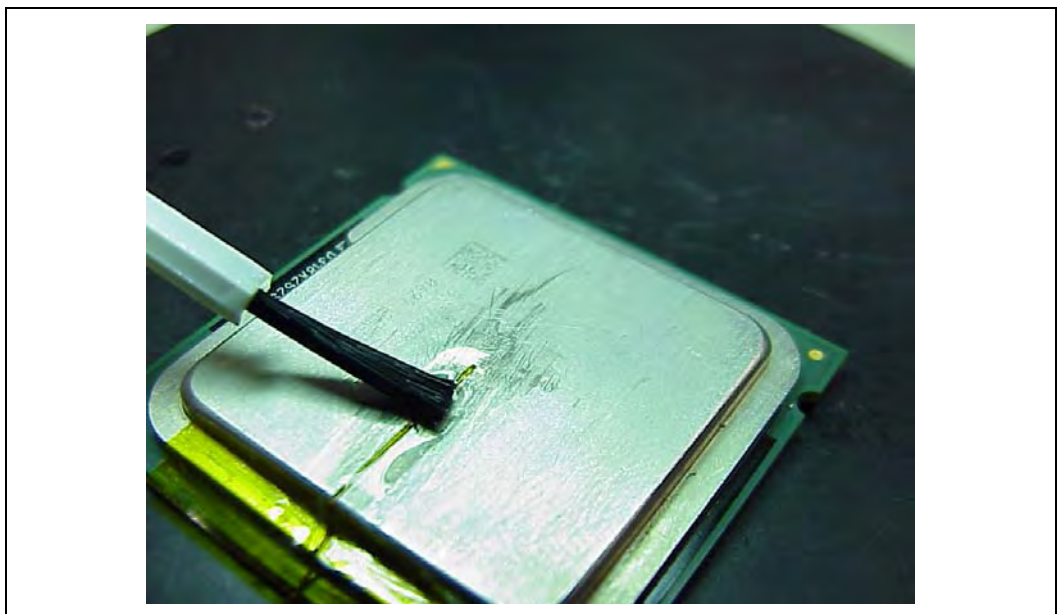


Figure 54. Removing Excess Adhesive from IHS

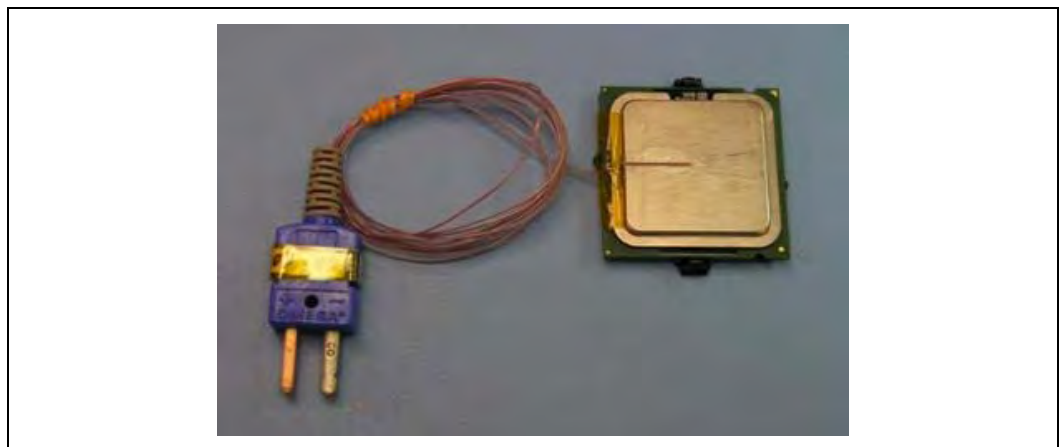


33. Using a blade, carefully shave any adhesive that is above the IHS surface (Figure 54). The preferred method is to shave from the edge to the center of the IHS.

Note: The adhesive shaving step should be performed while the adhesive is partially cured, but still soft. This will help to keep the adhesive surface flat and smooth with no pits or voids. If there are voids in the adhesive, refill the voids with adhesive and shave a second time.

34. Clean IHS surface with IPA and a wipe.
35. Clean the LGA pads with IPA and a wipe.
36. Replace the land side cover on the device.
37. Perform a final continuity test.
38. Wind the thermocouple wire into loops and secure or if provided by the vendor back onto the plastic roll. (Figure 55).

Figure 55. Finished Thermocouple Installation



39. Place the device in a tray or bag until it's ready to be used for thermal testing use.

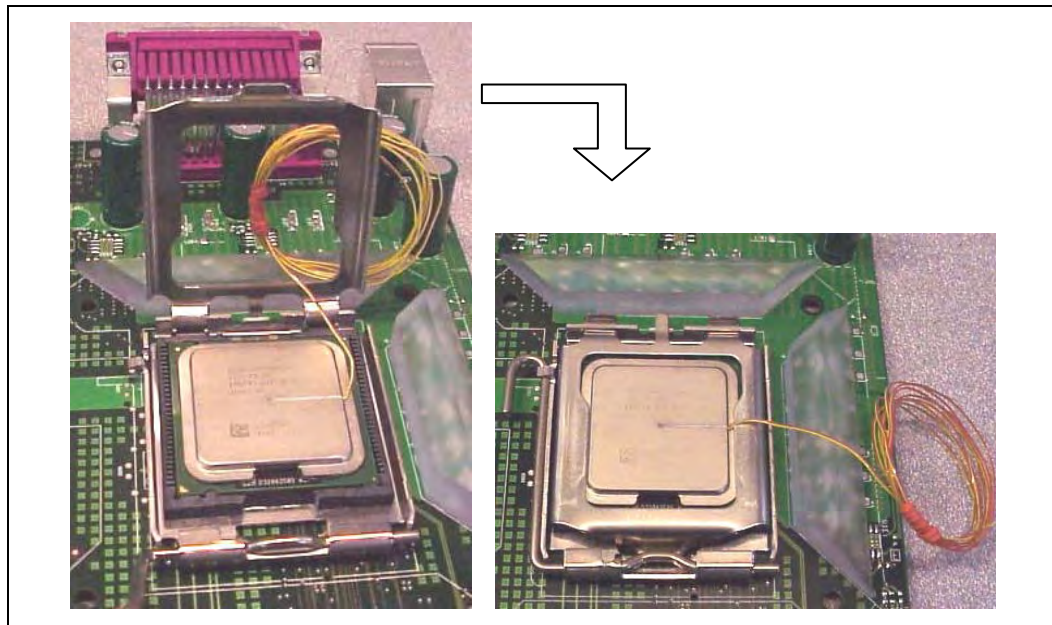
D.6 Thermocouple Wire Management

When installing the processor into the socket, make sure that the thermocouple wires exit above the load plate as Figure 56. Pinching the thermocouple wires between the load plate and the IHS will likely damage the wires.

Note: When thermocouple wires are damaged, the resulting reading maybe wrong. For example, if there are any cuts into the wires insulation where the wires are pinched between the IHS and the load plate, the thermocouple wires can get in contact at this location. In that case, the reported temperature would be the edge of the IHS/socket load plate area. This temperature is usually much lower than the temperature at the center of the IHS.

Prior to installing the heatsink, make sure that the thermocouple wires remain below the IHS top surface, by running a flat blade on top of the IHS for example.

Figure 56. Thermocouple Wire Management



S





Appendix E Legacy Fan Speed Control

A motherboard design may opt to use a SIO or ASIC based fan speed control device that uses the existing look up or state based fan speed control.

The fan speed control implementations consist of the following items

- A motherboard designed with a fan speed controller with the following functionality:
 - PWM fan control output
 - Remote digital thermal sensor measurement capability over the PECI bus.
- A motherboard with a 4 pin fan header for the processor heatsink fan.
- Processor heatsink with 4-wire PWM controlled Fan.
A thermistor in the fan hub is recommended, but not a requirement. The reference solution and the Boxed Processor will implement a thermistor into the design.

The following sections will discuss the necessary steps to implement Legacy Fan Speed Control.

E.1 Thermal Solution Design

The first step is to select or design a processor thermal solution that meets the thermal profile for the processor. See Section 2.2.2 for the definition of the thermal profile and consult the processor datasheet for the specific values.

The designer needs to ensure that when the heat sink fan is operating at full speed the thermal solution will meet the T_{C-MAX} limits at TDP. The slope of the thermal profile will allow the designer to make tradeoffs in thermal performance versus the inlet temperature to the processor fan heatsink.

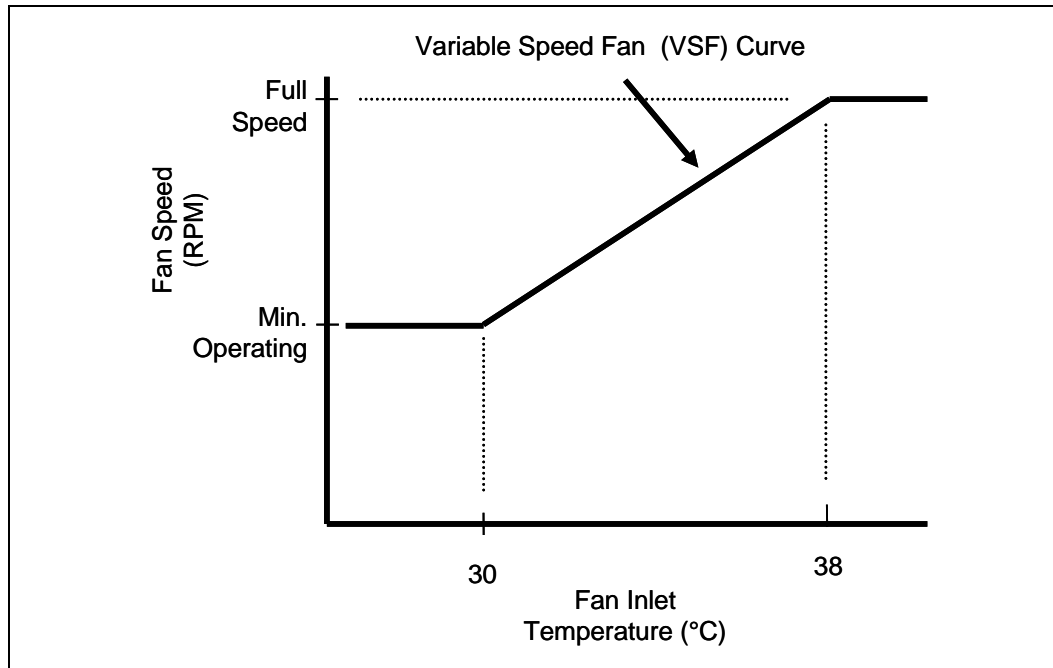
E.1.1 Determine Thermistor Set Points

A thermistor implemented in the hub of a fan is a first level of fan speed control. It provides an easy and cost effective means to begin acoustic noise reduction. It will, by design, run the fan at an appropriate speed based on the ambient conditions.

Chapter 5 discussed in detail the reference thermal solution, including the target Ψ_{CA} , fan speed based on temperature to ensure that T_{C-MAX} is not exceeded for TDP power at a given ambient temperature. The resulting variable speed fan (VSF) curve is the upper limit on fan speed.

The benefit of this upper limit will become more apparent when the fan speed controller is responding to the digital thermal sensor.

Figure 57. Thermistor Set Points



E.1.2 Minimum Fan Speed Set Point

The final aspect of thermal solution design is to determine the minimum speed the fan will be allowed to operate. This value can be driven by the cooling requirements for another portion of the design, such as the processor voltage regulator, or by functional limits of the fan design.

Per the *Fan Specification for 4 wire PWM Controlled Fans*; there are three possible options to consider

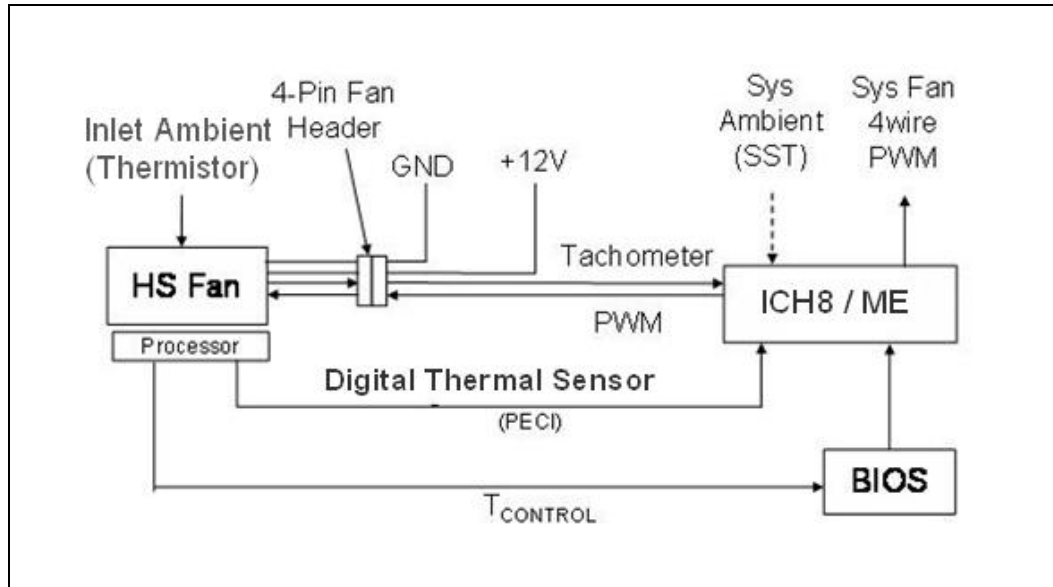
- Type A: The fan will run at minimum RPM for all PWM duty cycle values less than minimum duty cycle. This would be programmed into the fan controller located on the fan hub. It can not be overridden by the external fan speed control.
- Type B: The fan will run at minimum RPM for all non-zero PWM duty cycle values less than minimum duty cycle and turn off the fan at 0% PWM duty cycle.
- Type C: The fan will stop running when the current provided to the motor windings is insufficient to support commutation. The fan would turn off at 0% PWM duty cycle input.

For the reference thermal solution Type A was implemented.

E.2 Board and System Implementation

Once the thermal solution is defined, the system designer and board designer can define the fan speed control implementation. The first step is to select the appropriate fan speed controller (FSC). Figure 58 shows the major connections for a typical implementation.

Figure 58. Example Fan Speed Control Implementation



A number of major manufacturers have FSC components that include the necessary functionality to measure the temperature of the digital thermal sensor via the PECI interface and output a PWM signal. These components can be a discrete device or a super IO (SIO) with the functionality embedded. Intel has engaged with a number of major manufacturers of FSC components to provide devices that have a PECI host controller. Please contact your Intel Field Sales representative for the current list of manufacturers and visit their web sites or contact your local sales representatives for a part suitable for your design.

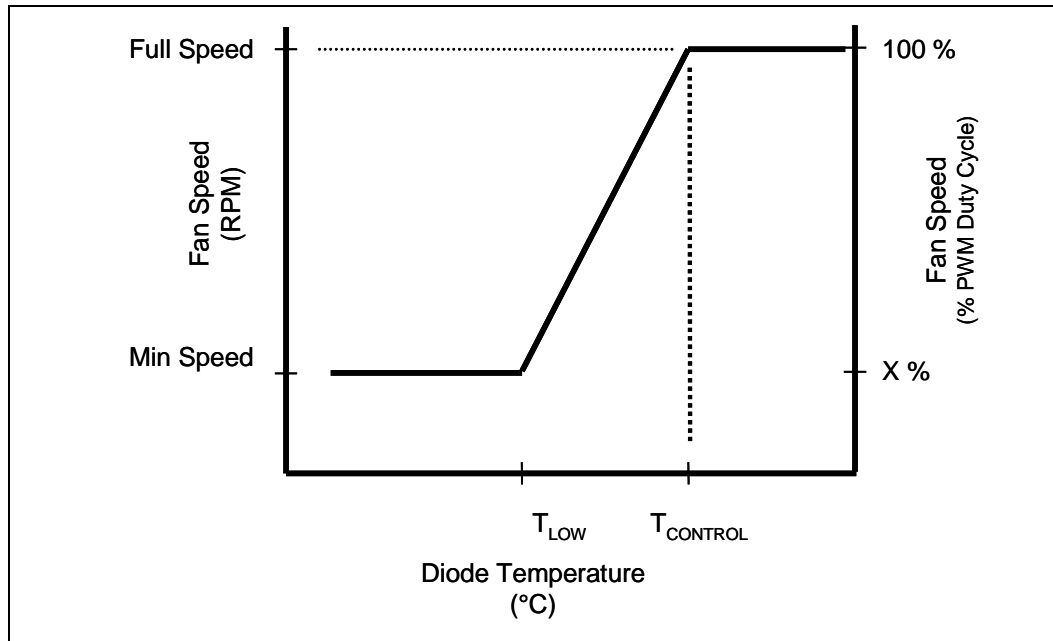
E.2.1 Choosing Fan Speed Control Settings

Fan speed control algorithms allow the system thermal engineer a number of options to consider. The typical control settings that need to be considered are:

- The temperature when the fan will begin to accelerate in response to the digital thermal sensor temperature (T_{LOW})
- The temperature where the fan is operating at full speed (100% PWM duty cycle). By specification this is $T_{CONTROL}$.
- The minimum fan speed (PWM duty cycle). For any digital thermal sensor temperature less than T_{LOW} the fan will run at this speed

These are the minimum parameters required to implement acoustic fan speed control. See Figure 59 for an example. There may be vendor specific options that offer enhanced functionality. See the appropriate vendor datasheet on how to implement those features.

Figure 59. Fan Speed Control



E.2.1.1 Temperature to Begin Fan Acceleration

The first item to consider is the value for T_{LOW} . The FSC device needs a minimum temperature to set as the threshold to begin increasing PWM duty cycle to the fan.

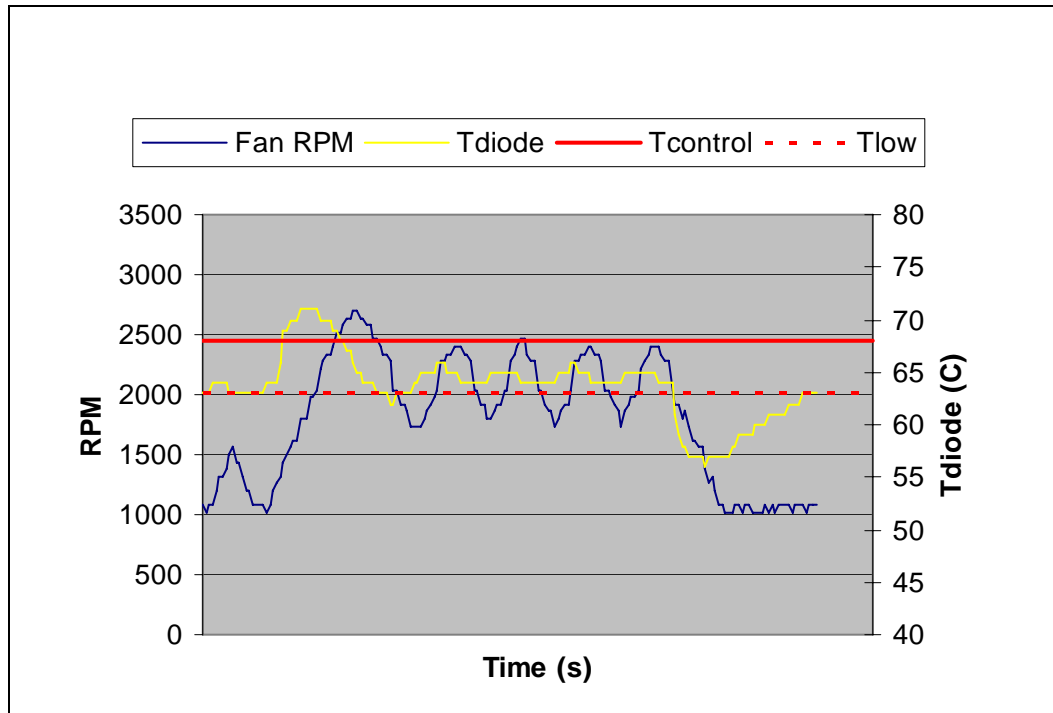
The system designer might initially consider a small temperature range ($T_{CONTROL} - T_{LOW} = T_{RANGE}$), 5°C to accelerate the fan. That would delay the fan accelerating for the longest time after an increase in T_{SENSOR} . There are a number of issues that should be considered with this strategy

- There is little granularity in the fan speeds. For each 1°C of increase in diode temperature = 20% jump in PWM duty cycle %
- Fan speed oscillation as the thermal solution chases the digital thermal sensor temperature
- Having T_{SENSOR} overshoot $T_{CONTROL}$ and the thermal profile causing the Thermal Control Circuit to activate to reduce the temperature.
- In extreme cases Thermtrip# activates and shuts down the processor

The first two cases can create a poor acoustic response for the user. The third case the user could notice a drop in performance as the thermal control circuit reduces the power. The Figure 60 is an example of this situation. The system begins at idle and the Maxpower program is started at 65% workload.



Figure 60. Temperature Range = 5 °C



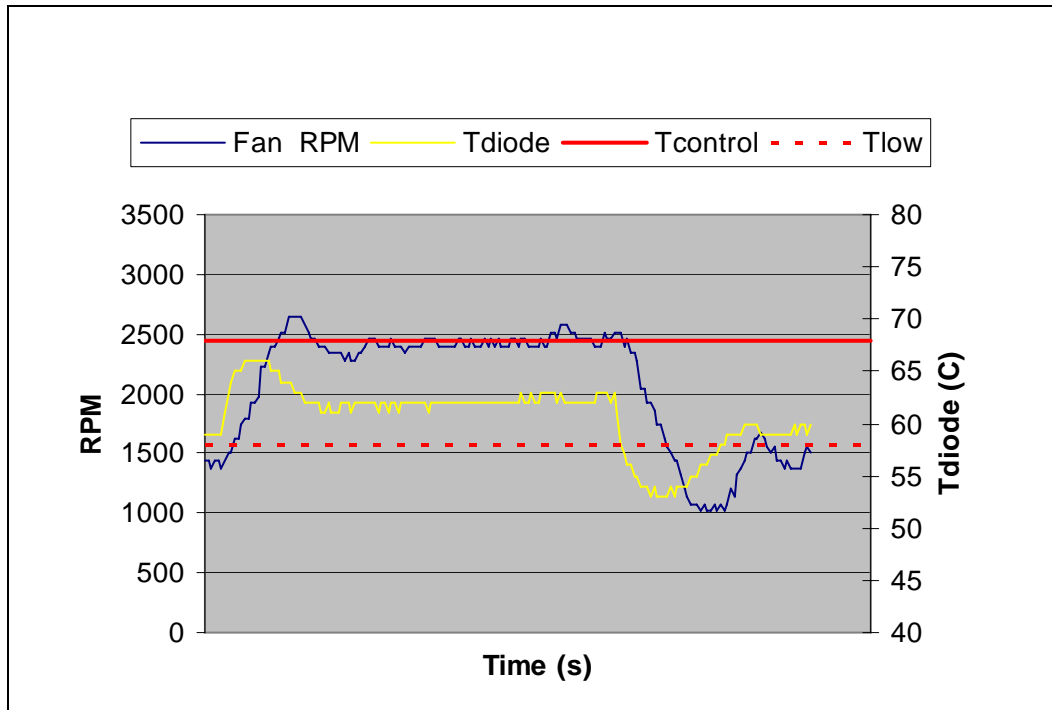
An alternate would be to consider a slightly larger value such as $T_{RANGE} = 10\text{ }^{\circ}\text{C}$. In this case the design is trading off the acoustic margin for thermal margin.

- There is increased granularity in the fan speeds.
- Fan speed oscillation are significantly reduced
- Maximum fan speed is lower

The rate of change of Ψ_{CA} vs. RPM is an exponential curve with a larger decrease at the beginning of the fan acceleration than as the maximum speed is approached. By having the fan start to accelerate at a lower T_{SENSOR} reading the thermal solution can keep up with rate of change in processor power. The rate of change in acoustics (dBA) is more linear with RPM. When comparing these two metrics the choice of a larger T_{RANGE} value becomes a more acceptable trade off. Figure 61 graphs the system at the same conditions as in Figure 60 but $T_{RANGE} = 10^{\circ}$.



Figure 61. Temperature Range = 10 °C



It should be noted that having T_{SENSOR} above T_{CONTROL} is expected for workloads near TDP power levels and high system ambient. See Section E.4 for additional discussion on T_{CONTROL} versus Thermal Profile

For use with the ATX Boxed Processor enabled reference solution a T_{RANGE} value of 10°C is recommended. For BTX Boxed Processor enabled reference solutions T_{RANGE} value of 7 °C is recommended.

E.2.1.2 Minimum PWM Duty Cycle

The final step in determining the FSC setting is to determine the minimum PWM Duty cycle. This is the fan speed for any $T_{\text{SENSOR}} < T_{\text{LOW}}$. The selection of this value is dependent on

- Acoustic target at system idle
- Voltage regulator cooling

For a motherboard design intending to use the Boxed Processor or the enabled reference thermal solution the recommended minimum PWM duty cycle is 20%.

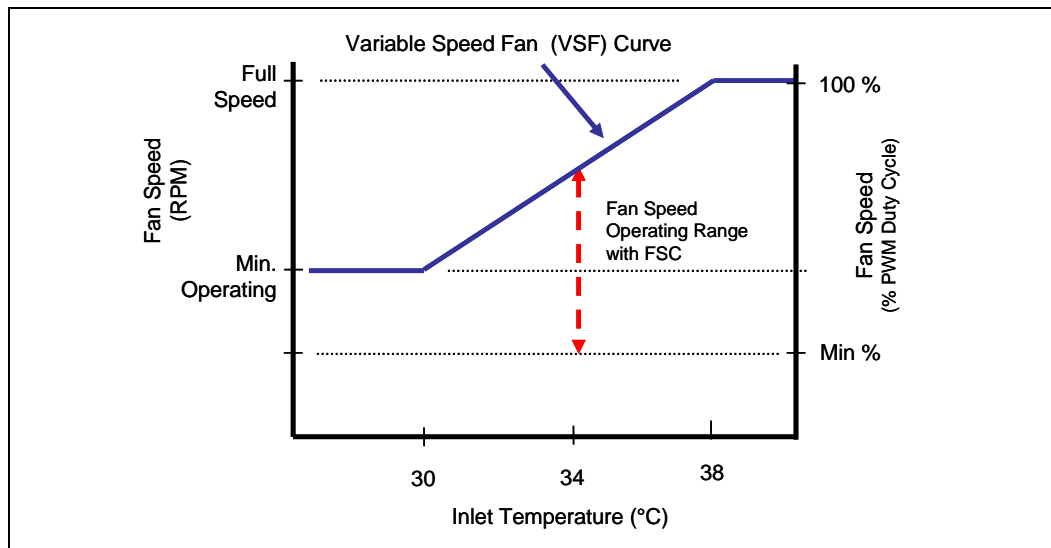
Note: Set minimum PWM Duty Cycle only as low as required to meet acoustic requirements. The FSC design needs to accommodate transition from a low power state to TDP workloads without having PROCHOT# becoming active.



E.3 Combining Thermistor and Digital Thermal sensor Control

There is no closed loop control between the FSC and the thermistor, but they work in tandem to provide the maximum fan speed reduction. As discussed in Section E.1.1, the thermistor establishes the VSF curve. This curve will determine the maximum fan speed as a function of the ambient temperature and by design provides a Ψ_{CA} sufficient to meet the thermal profile. The FSC, by measuring the processor digital thermal sensor will command the fan to reduce speed below the VSF curve in response to processor workload. Conversely if the processor workload increases the FSC will command the fan via the PWM duty cycle to accelerate the fan up to the limit imposed by the VSF curve.

Figure 62. Digital Thermal Sensor and Thermistor



E.4 Interaction of Thermal Profile and $T_{CONTROL}$

The processor thermal specification is comprised of the two parameters, $T_{CONTROL}$ and Thermal Profile. The minimum requirement for thermal compliance is to ensure the thermal solution, by design, meets the thermal profile.

If the system design will incorporate acoustic speed fan control, Intel requires monitoring the digital thermal sensor to implement acoustic fan speed control. The value of the digital thermal sensor temperature determines which specification must be met.

- Digital thermal sensor less than $T_{CONTROL}$
 - When the thermal solution can maintain the thermal sensor temperature to less than $T_{CONTROL}$ then the fan speed can be reduced. .
- Digital thermal sensor greater than $T_{CONTROL}$
 - The T_C must be maintained at or below the Thermal Profile for the measured power dissipation.



To use all of the features in the Intel reference heatsink design or the Boxed Processor, system integrators should verify the following functionality is present in the board design. Refer to the *Fan Specification for 4 wire PWM Controlled Fans* and Chapter 5 for complete details on the Intel enabled thermal solution.

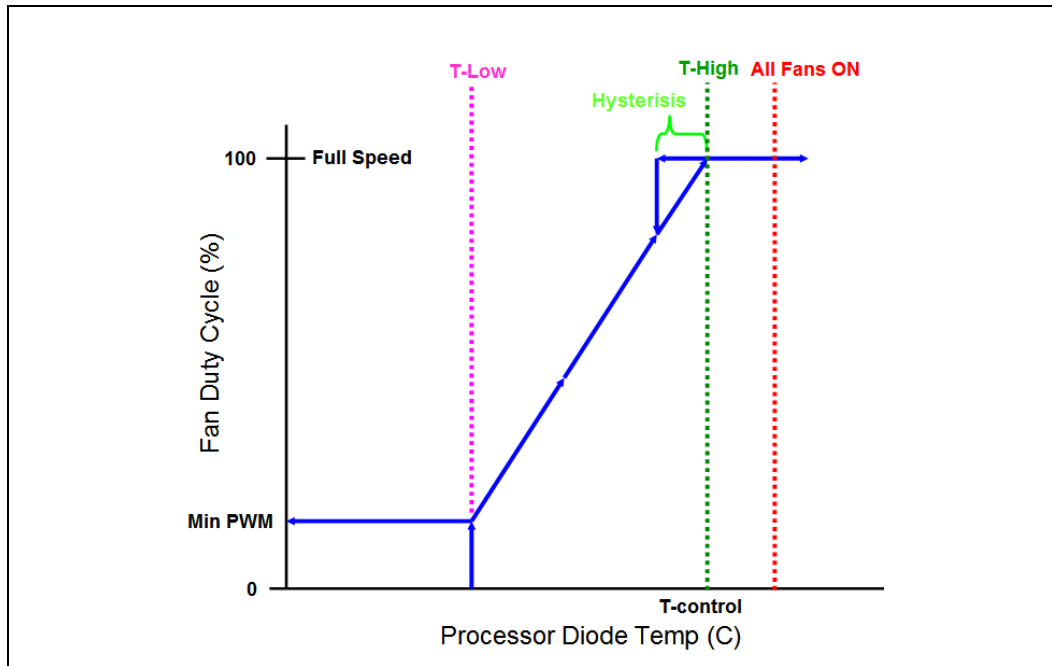
The FSC definitions are listed in Table 12.

Table 12. FSC Definitions

Item	Definition
T _{SENSOR}	Temperature reported from the processor digital thermal sensor.
T _{CONTROL}	T _{CONTROL} is the specification limit for use with the digital thermal sensor
T _{LOW}	The temperature above which the fan will begin to accelerate in response to the digital thermal sensor temperature.
Hysteresis	The number of degrees below T _{CONTROL} the fans will remain on before slowing down.
T _{HIGH}	The temperature at which the fan is operating at full speed (100% PWM Duty Cycle). By specification this is T _{control} .
All Fans ON	The processor temperature at which all fans in the system are increased to 100% Duty Cycle.
Min PWM	Minimum pulse width modulation (% duty cycle) that the fans will run at when T _{SENSOR} is less than T _{LOW} .
Spin-up	Amount of time fan is run at 100% duty cycle to overcome fan inertia.
PWM Freq	The operating frequency of the PWM signal.
T _{AVERAGING}	The time (in seconds) that elapses while the fan is gradually sped up in response to a processor temperature spike.



Figure 63. FSC Definition Example



Requirements Classification

- Required – an essential part of the design necessary to meet specifications. Should be considered a pass or fail in selection of a board.
- Suggested – highly desired for consistency among designs. May be specified or expanded by the system integrator.

The motherboard needs to have a fan speed control component that has the following characteristics:

- PWM output programmable to 21-28 kHz (required). PWM output set to 25 kHz (Suggested) as this value is the design target for the reference and for the Boxed Processor.
- External/remote thermal sensor measurement capability (required). Must support PECI and thermal diode via an SST device
- External/remote thermal sensor sampling rate ≥ 4 times per second (required).
- External/remote diode measurement (SST device) is calibrated by the component vendor to account for the diode ideality and package series resistance as listed in the appropriate datasheet. (Suggested).

Note: If the SST thermal sensor is not calibrated with the diode ideality and package series resistance, verify the board manufacturer has made provisions within the BIOS setup or other utility to input the corrections factors.

The BIOS, at a minimum, must program the settings in Table 13 or Table 14, as appropriate, into the fan speed controller. The values are the minimum required to establish a fan speed control algorithm consistent with this document, the reference thermal solution and Boxed Processor thermal solution.



Table 13. ATX FSC Settings

Parameter	Classification	Processor Thermal Sensor	PWM Output	Notes
T _{HIGH}	Required	T _{CONTROL}		3
T _{LOW}	Required	T _{CONTROL} – 10 °C		3
Minimum PWM Duty Cycle	Required		20%	
PWM Frequency	Required		21-28 kHz	1
Spin-up time	Suggested		250 - ~500 ms	2, 4
T _{AVERAGING}	Suggested	35 sec		4
When T _{SENSOR} < T _{LOW}	Suggested	Minimum PWM%		
All Fans ON	Suggested	T _{CONTROL} + 3 °C		
Hysteresis	Suggested	2 °C		

NOTES:

1. A PWM frequency of 25 kHz is the design target for the reference and for the Intel® Boxed Processor and the reference design..
2. Use the lowest time available in this range for the device selected.
3. To ensure compliance with the thermal specification, thermal profile and usage of the T_{SENSOR} for fan speed control these setting should not be user configurable.
4. If this function is present on the device it must be enabled

Table 14. BTX Fan Speed Control Settings

Parameter	Classification	Processor Thermal Sensor	System Ambient Sensor	PWM Output	Notes
T _{HIGH}	Required	T _{CONTROL}	54 °C		3,5
T _{LOW}	Required	T _{CONTROL} – 7 °C	47 °C		3,5
Minimum PWM Duty Cycle	Required			PWM 1 (TMA) –20%	
PWM Frequency	Required			21-28 kHz	1
Spin Up Time	Suggested			250 – ~ 500 ms	2, 7
T _{AVERAGING}	Suggested	4.0 sec	4.0 sec		3, 7
When T _{SENSOR} < T _{LOW}	Suggested	Minimum PWM%	Minimum PWM%		
All Fans On	Suggested	T _{CONTROL} + 3 °C	65 °C		
Hysteresis	Suggested	2 °C	4 °C		

NOTES:

1. A PWM frequency of 25 kHz is the design target for the reference and for the Intel® Boxed Processor and the reference design.
2. Use the lowest time available in this range for the device selected
3. T_{AVERAGING} = represents the amount of delay time before responding to the temperature change, defined in fan speed control device (sometimes called ramp range control or



- spike smoothing). Please select the lowest setting available close to 4.0 seconds by the fan speed control device
4. The Fan Speed Controller, or Health Monitor Component, takes the result of the two fan speed ramps (processor and system) and drives the TMA fan to the highest resulting PWM duty cycle (%)
 5. For BTX systems a second thermal sensor is recommended to capture chassis ambient for more detail see Appendix F.
 6. To ensure compliance with the thermal specification, thermal profile and usage of the T_{SENSOR} for fan speed control these setting should not be user configurable.
 7. If this function is present on the device it must be enabled

Note: The fan speed component vendors provide libraries that are used by the BIOS writer to program the component registers with the parameters listed above. Consult the appropriate vendor datasheet for detailed information on programming their component.

§





Appendix F BTX System Thermal Considerations

There are anticipated system operating conditions in which the processor power may be low but other system component powers may be high. If the only Fan Speed Control (FSC) circuit input for the Thermal Module Assembly (TMA) fan is from the processor diode then the fan speed and system airflow is likely to be too low in this operating state. Therefore, it is recommended that a second FSC circuit input be acquired from an ambient temperature monitor location within the system.

The location of the System Monitor thermal sensor is best determined through extensive system-level numerical thermal modeling or prototype thermal testing. In either case, the temperature of critical components or the air temperature near critical components should be assessed for a range of system external temperatures, component powers, and fan speed operating conditions. The temperature at the selected location for the System Monitor Point should be well correlated to the temperatures at or near critical components. For instance, it may be useful to monitor the temperature near the PSU airflow inlet, near the graphics add-in card, or near memory.

The final system integrator is typically responsible for ensuring compliance with the component temperature specifications at all operating conditions and, therefore, should be responsible for specifying the System Monitor thermal sensor location. However, it is not always possible for a board supplier – especially a channel board supplier – to know the system into which a board will be installed. It is, therefore, important for BTX board suppliers to select a System Monitor thermal sensor location that will function properly in most systems.

A BTX system should be designed such that the TMA exhaust is the primary airflow stream that cools the rest of the system. The airflow passes through the chipset heatsink and its temperature will rise as the memory controller chipset power increases. Since chipset power will increase when other subsystems (e.g. memory, graphics) are active, a System Monitor thermal sensor located in the exhaust airflow from the chipset heatsink is a reasonable location.

It is likely that a thermal sensor that is not mounted above the board and in the chipset exhaust airflow will reflect board temperature and not ambient temperature. It is therefore recommended that the Thermal sensor be elevated above the board.



The thermal sensor location and elevation are reflected in the Flotherm thermal model airflow illustration and pictures (see Figure 64 and Figure 65). The Intel® Boxed Boards in BTX form factor have implemented a System Monitor thermal sensor. The following thermal sensor or its equivalent can be used for this function:

Part Number: C83274-002
BizLink USA Technology, Inc.
44911 Industrial Drive
Fremont, CA 94538 USA
(510)252-0786 phone
(510)252-1178 fax
sales@bizlinktech.com

Part Number: 68801-0170
Molex Incorporated
2222 Wellington Ct.
Lisle, IL 60532
1-800-78MOLEX phone
1-630-969-1352 fax
amerinfo@molex.com

Figure 64. System Airflow Illustration with System Monitor Point Area Identified

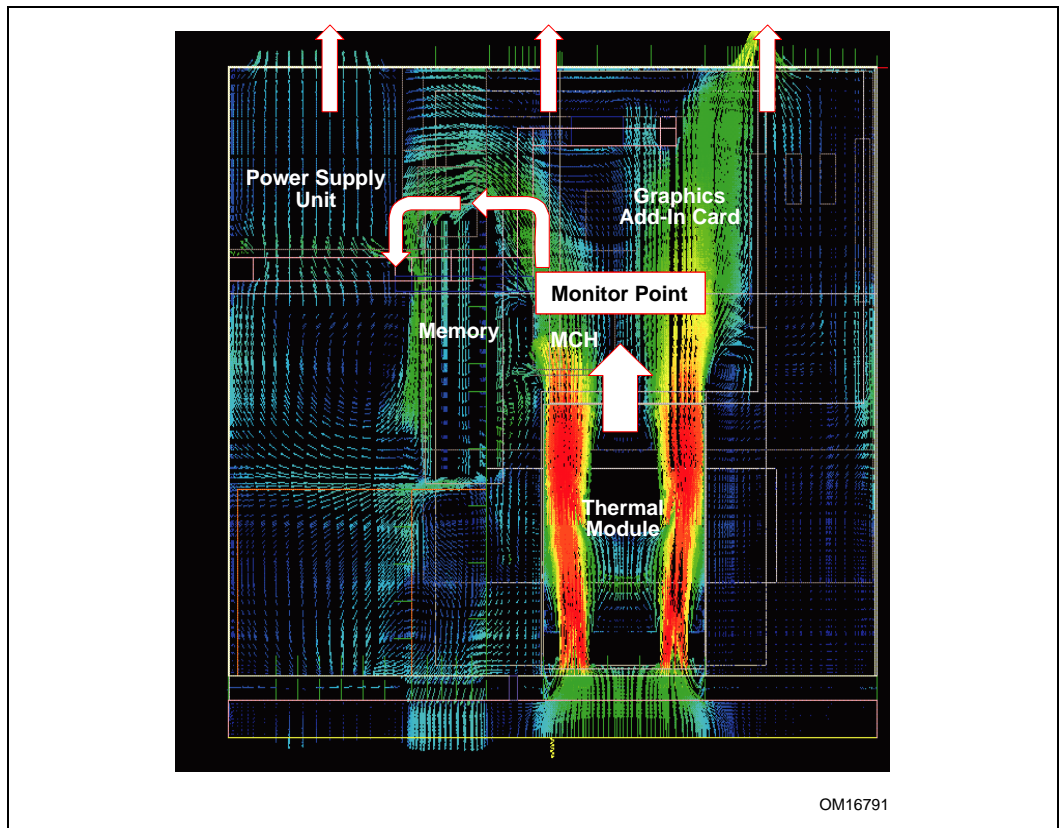
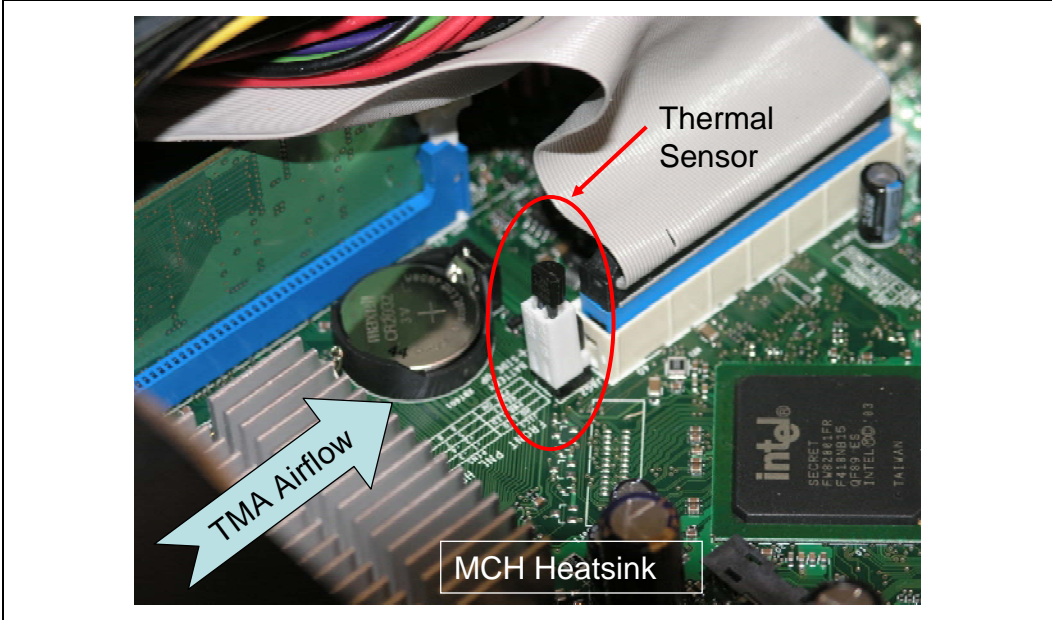




Figure 65. Thermal sensor Location Illustration



S





Appendix G Mechanical Drawings

The following table lists the mechanical drawings included in this appendix. These drawings refer to the reference thermal mechanical enabling components for the processor.

Note: Intel reserves the right to make changes and modifications to the design as necessary.

Drawing Description	Page Number
ATX/μATX Motherboard Keep-out Footprint Definition and Height Restrictions for Enabling Components - Sheet 1	114
ATX/μATX Motherboard Keep-out Footprint Definition and Height Restrictions for Enabling Components - Sheet 2	115
ATX/μATX Motherboard Keep-out Footprint Definition and Height Restrictions for Enabling Components - Sheet 3	116
. Balanced Technology Extended (BTX) Thermal Module Keep Out Volumetric – Sheet 1	117
Balanced Technology Extended (BTX) Thermal Module Keep Out Volumetric – Sheet 2	118
. Balanced Technology Extended (BTX) Thermal Module Keep Out Volumetric – Sheet 3	119
Balanced Technology Extended (BTX) Thermal Module Keep Out Volumetric – Sheet 4	120
Balanced Technology Extended (BTX) Thermal Module Keep Out Volumetric – Sheet 5	121
Intel Advanced Liquid Cooling Technology Assembly	122



Figure 66. ATX/μATX Motherboard Keep-out Footprint Definition and Height Restrictions for Enabling Components - Sheet 1

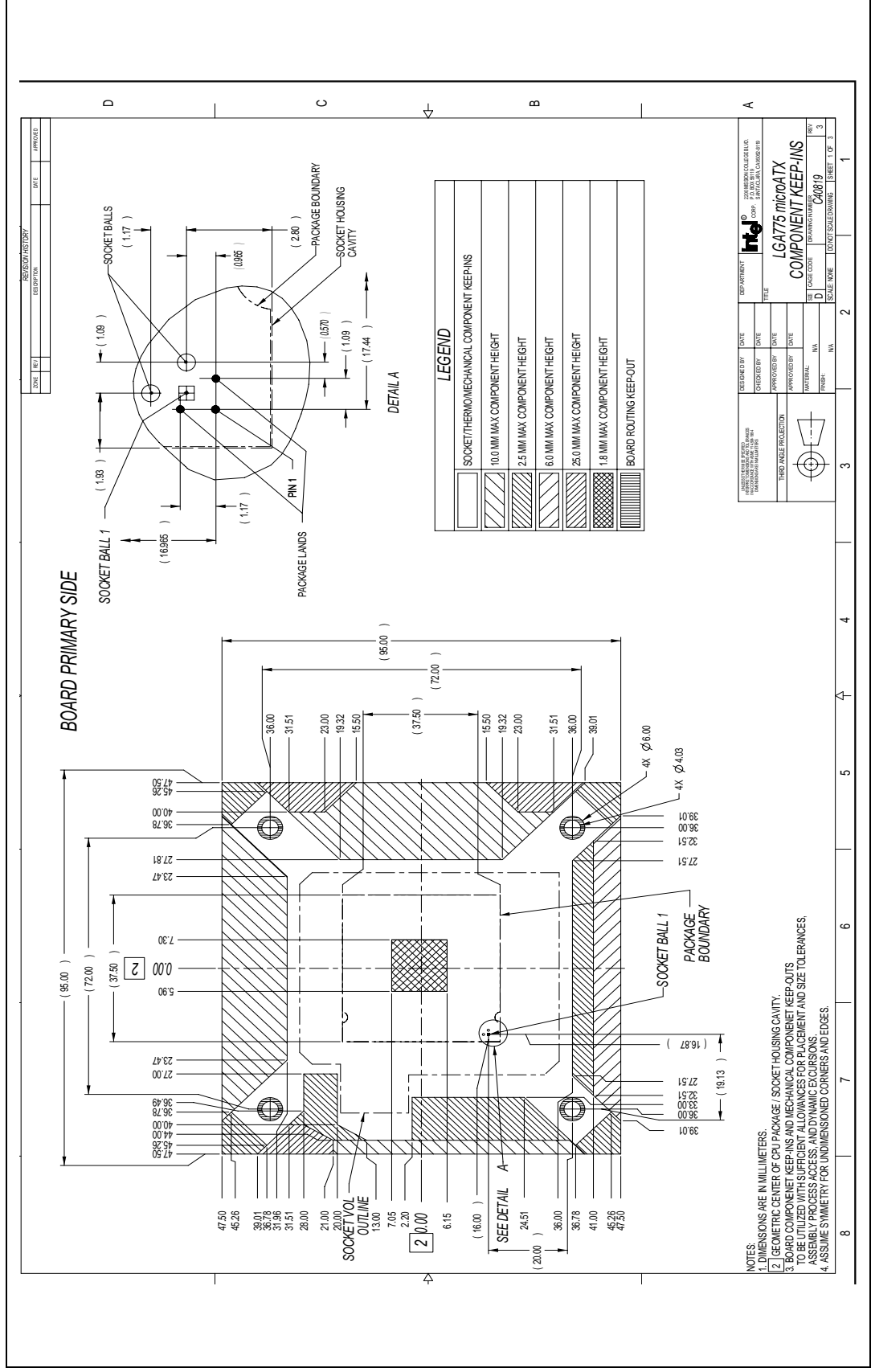




Figure 67. ATX/μATX Motherboard Keep-out Footprint Definition and Height Restrictions for Enabling Components - Sheet 2

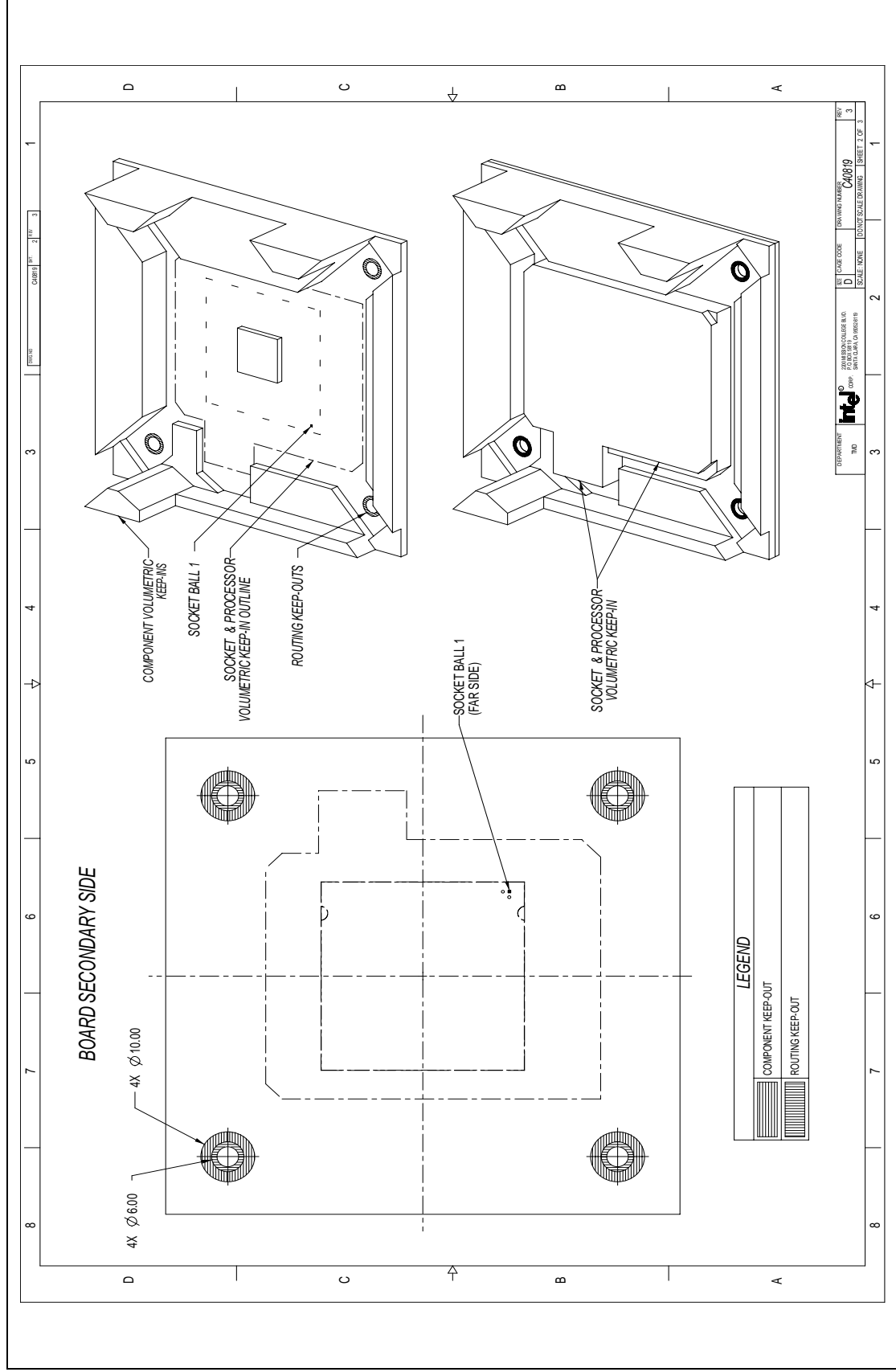




Figure 68. ATX/μATX Motherboard Keep-out Footprint Definition and Height Restrictions for Enabling Components - Sheet 3

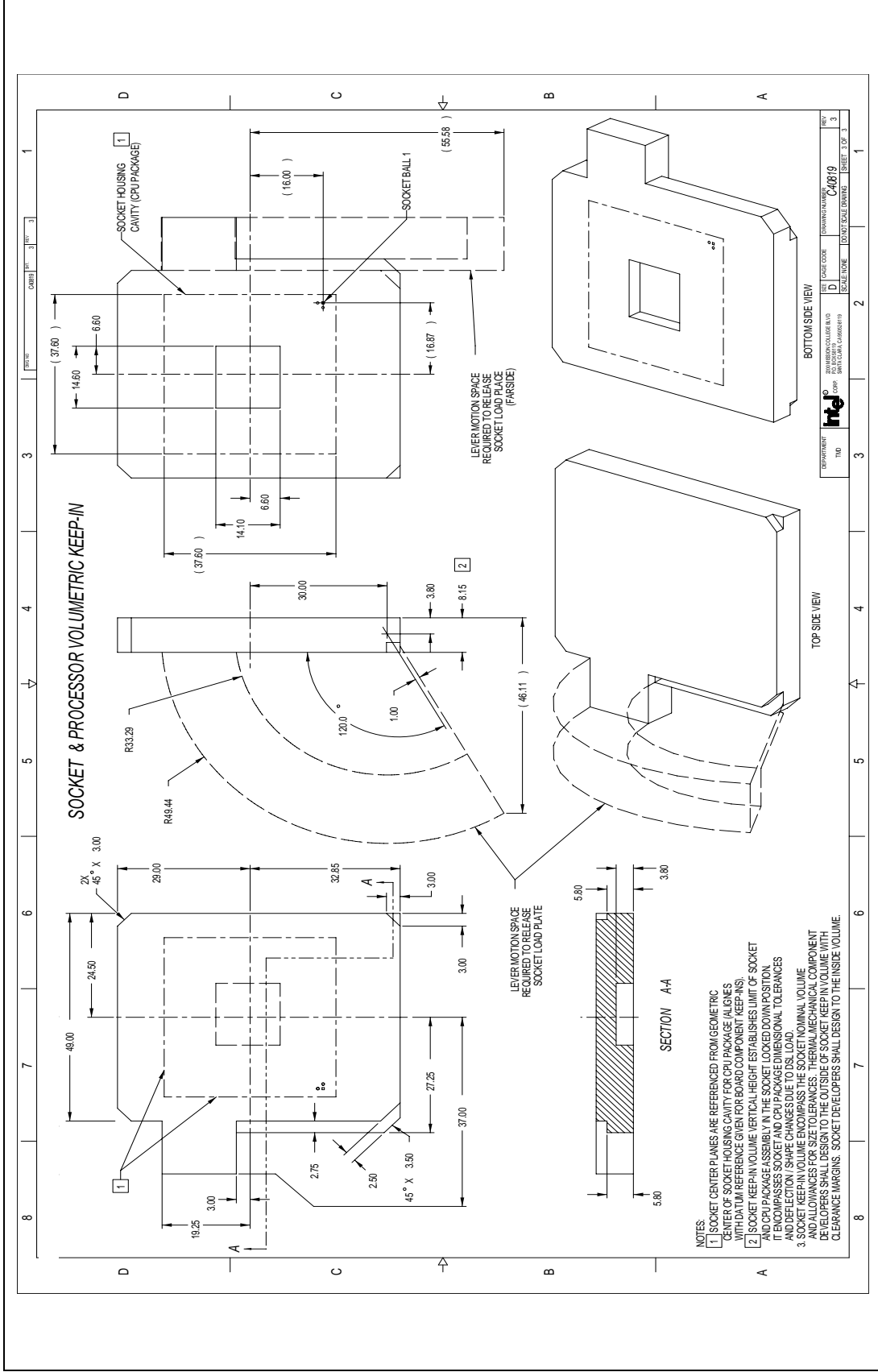




Figure 69. Balanced Technology Extended (BTX) Thermal Module Keep Out Volumetric – Sheet 1

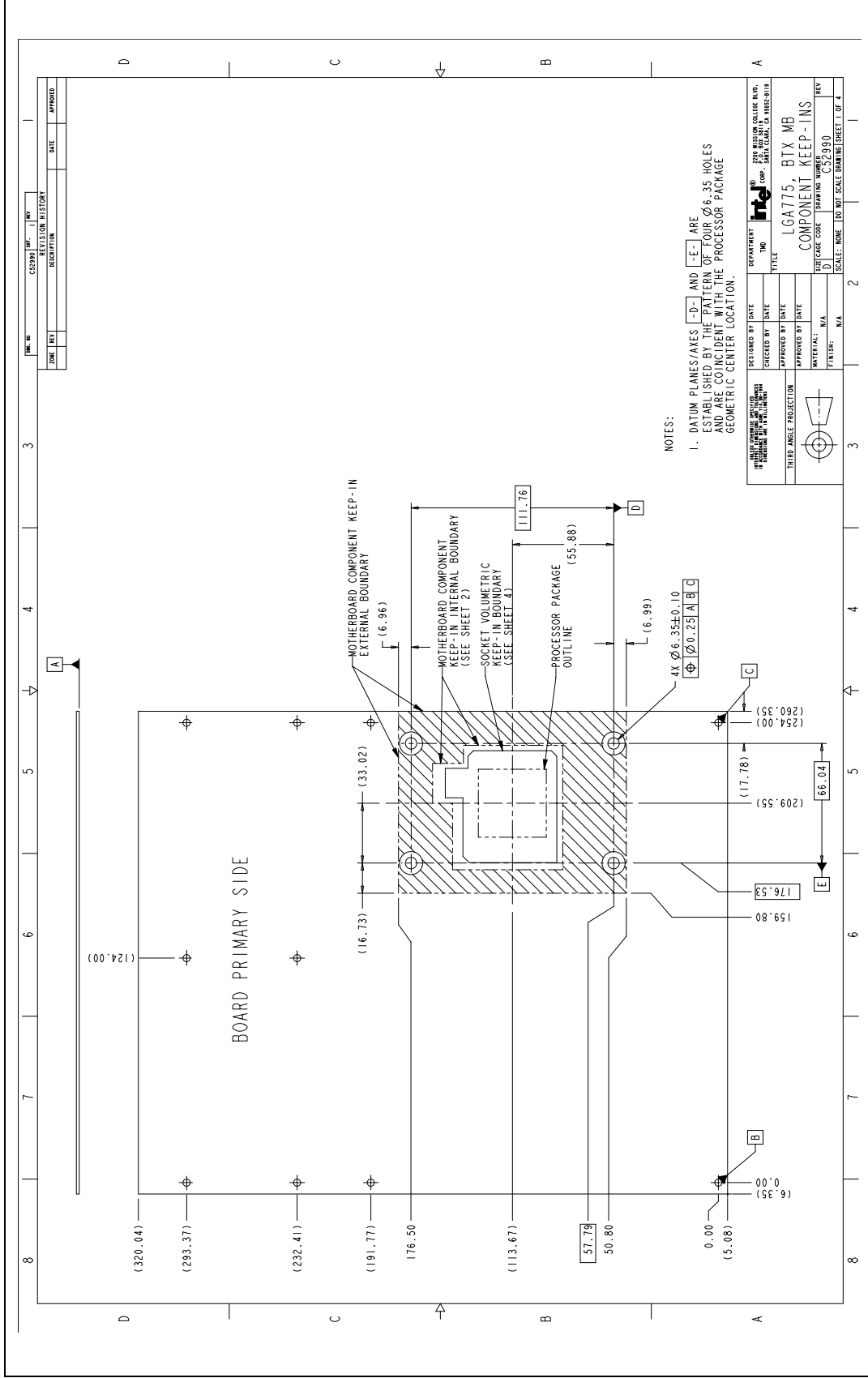




Figure 70. Balanced Technology Extended (BTX) Thermal Module Keep Out Volumetric – Sheet 2

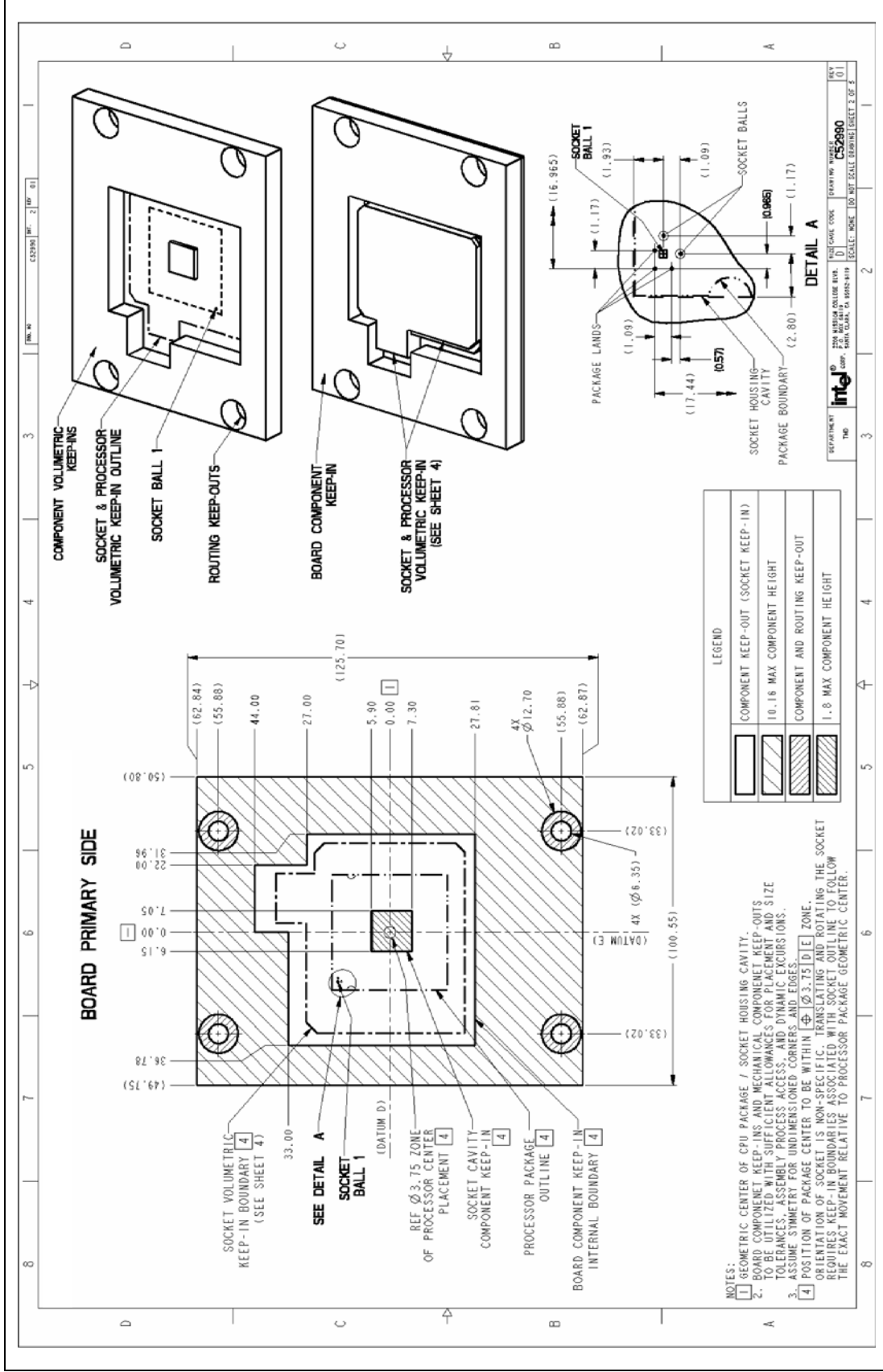




Figure 71. Balanced Technology Extended (BTX) Thermal Module Keep Out Volumetric – Sheet 3

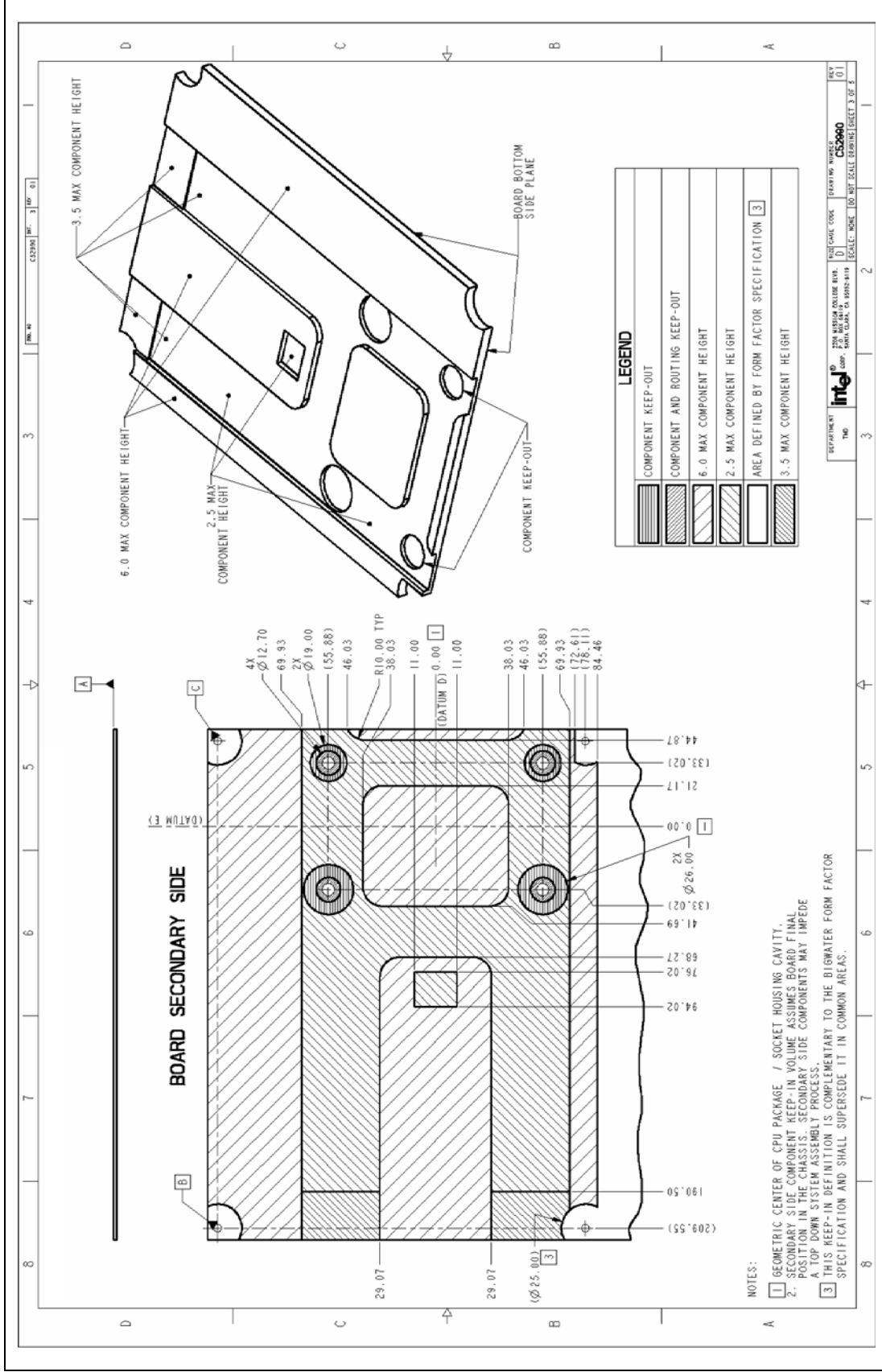




Figure 72. Balanced Technology Extended (BTX) Thermal Module Keep Out Volumetric – Sheet 4

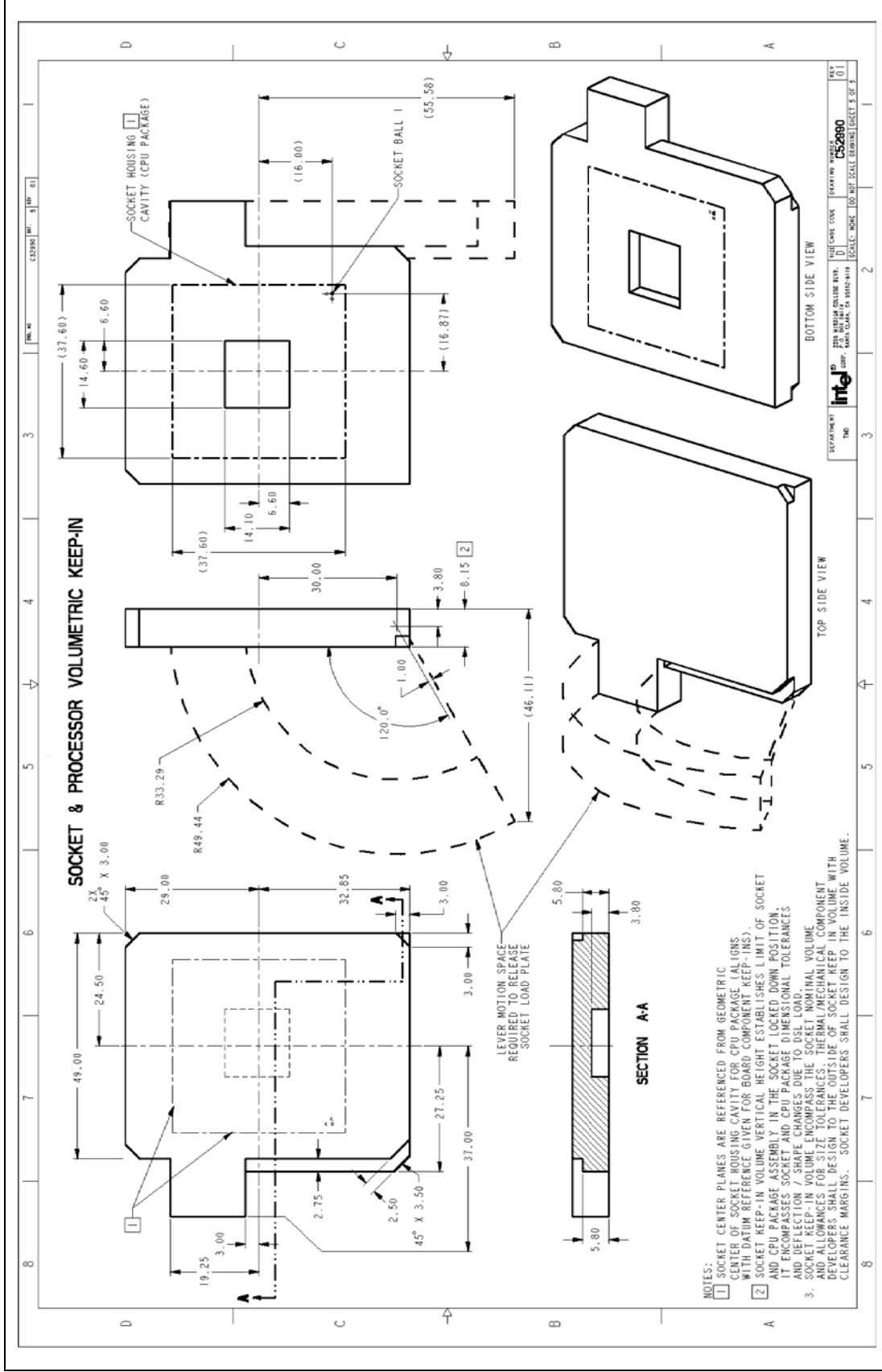




Figure 73. Balanced Technology Extended (BTX) Thermal Module Keep Out Volumetric – Sheet 5

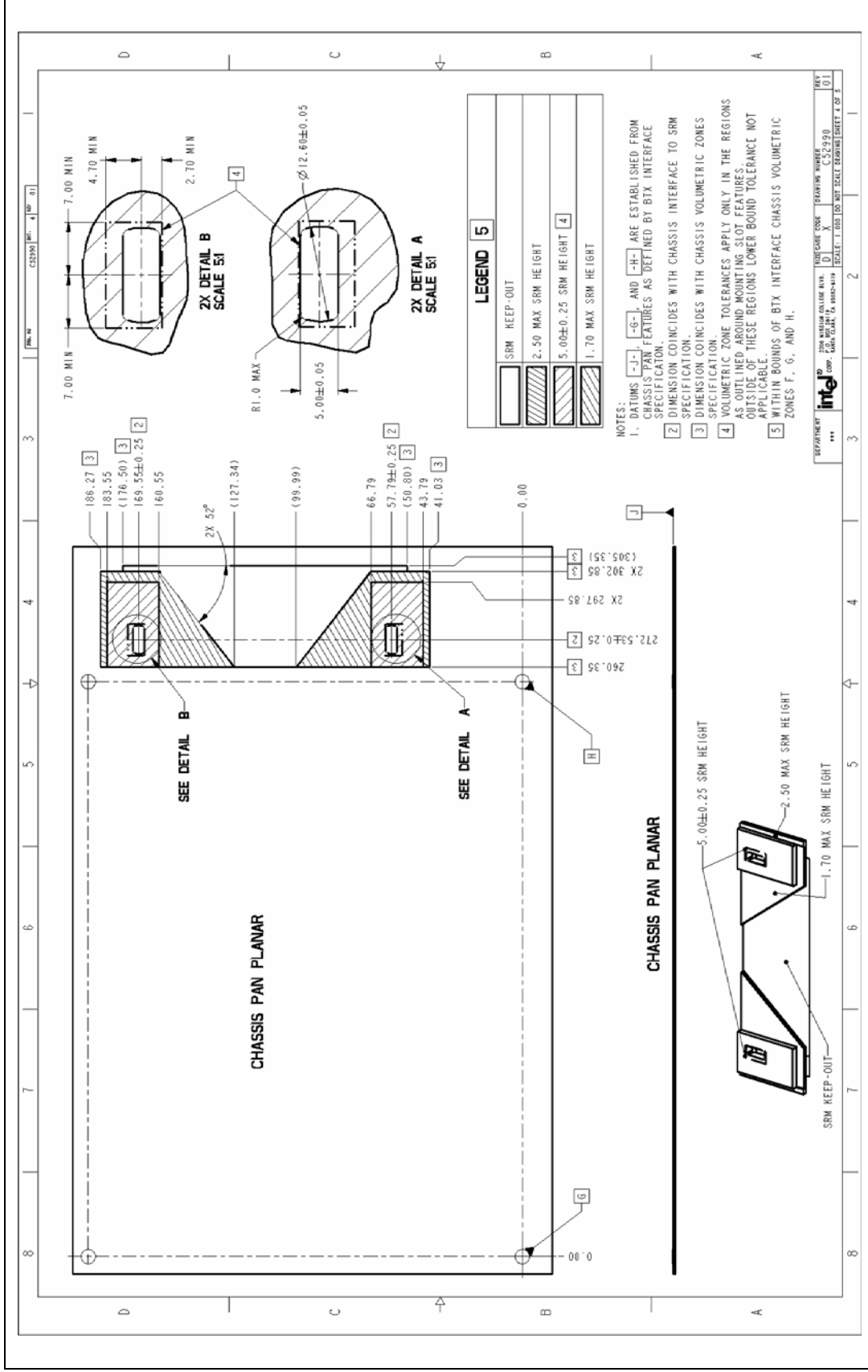
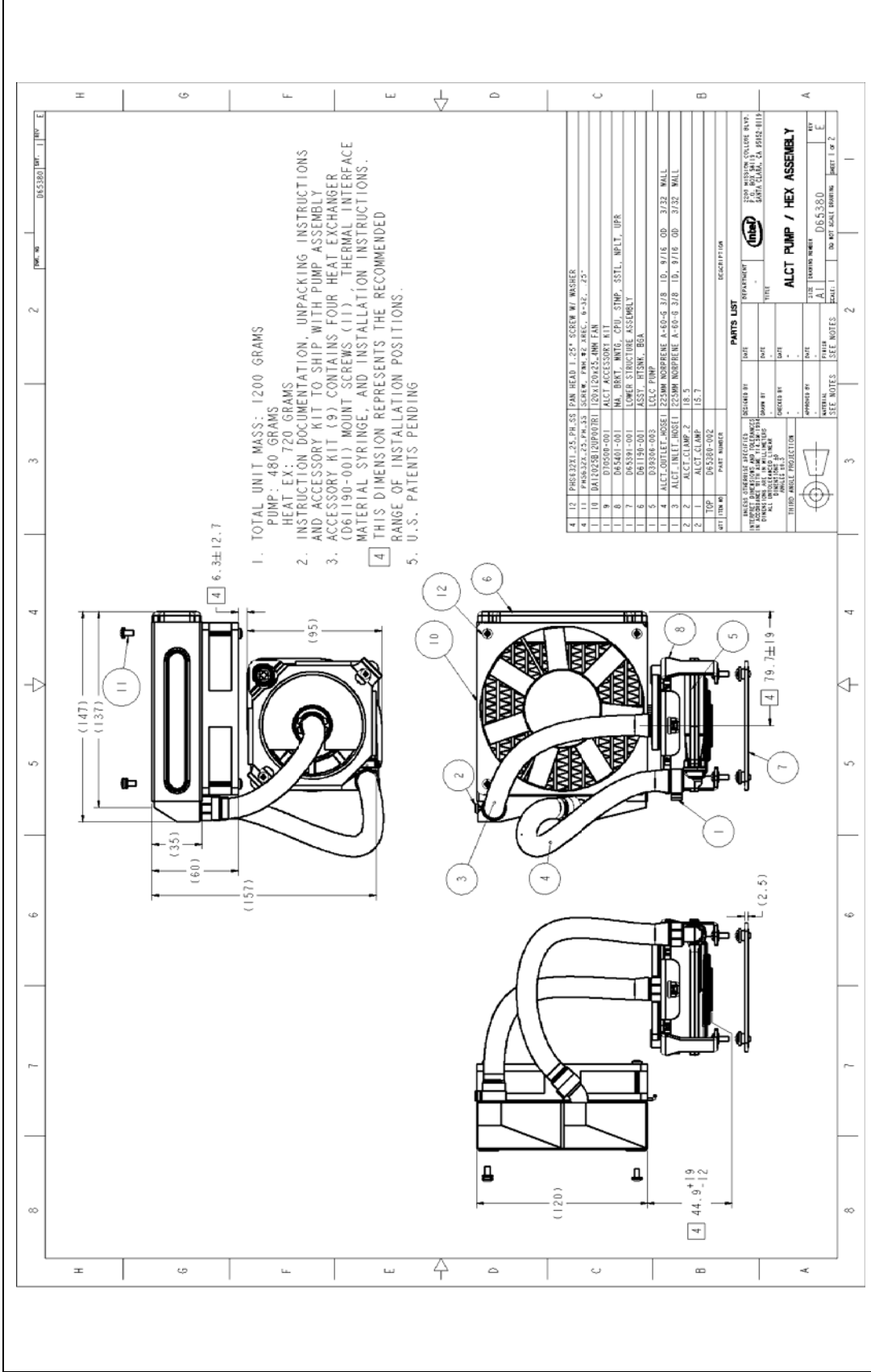


Figure 74. Intel Advanced Liquid Cooling Technology Assembly





Appendix H Intel Enabled Reference Solution Information

This appendix includes supplier information for Intel enabled vendors for the Intel® Core™2 Extreme processor QX6800 B3 Stepping and QX9770 C0 Stepping reference ATX thermal solution.

The reference component designs are available for adoption by suppliers and heatsink integrators pending completion of appropriate licensing contracts. For more information on licensing, please contact the Intel representative mentioned in Table 15.

Table 15. Intel Representative Contact for Licensing Information

Company	Contact	Phone	Email
Intel Corporation	Tony Deleon	(253) 731-9339	tony.deleon@intel.com

Table 16 lists suppliers that produce Intel enabled reference components. The part numbers listed below identifies these reference components. End-users are responsible for the verification of the Intel enabled component offerings with the supplier. OEMs and System Integrators are responsible for thermal, mechanical, and environmental validation of these solutions.

Table 16. Intel Reference Component ATX Thermal Solution Providers

Supplier	Part Description	Part Number	Contact	Phone	Email
AVC* (ASIA Vital Components Co., Ltd)	Intel® ALCT Reference Heatsink	TBD	David Chao	+886-2-22996930 Extension: 619	david_chao@avc.com.tw

Note: These vendors and devices are listed by Intel as a convenience to Intel's general customer base, but Intel does not make any representations or warranties whatsoever regarding quality, reliability, functionality, or compatibility of these devices. This list and/or these devices may be subject to change without notice.