

# Section II



Teacher Timeline:  
A Week-by-Week Guide

## Contents

---

### *Section II – Teacher Timeline: A Week-by-Week Journey to the Fair*

	<b>Page</b>
<b>Stage 1: Getting Ready.....</b>	<b>21</b>
Week 1 Gearing Up .....	22
Week 2 Club: Publicize Science Fair Program/Students Apply .....	28
Week 3 Club: Selection and Notification of New Members .....	31
<b>Stage 2: Learning Through Group Investigations .....</b>	<b>32</b>
Week 4 First Science Group Investigation .....	33
Week 5 Introduction to Science Inquiry: Cars & Ramps .....	38
Week 6 Writing Procedures.....	45
Week 7 Group Investigation: “Comeback Can” Races .....	48
Week 8 More Group Investigations .....	52
Week 9 Managing Data and Bar Graphs.....	61
Week 10 Managing Data and Line Graphs.....	65
Week 11 Investigative Questions.....	69
<b>Stage 3: Students Prepare for Their Own Investigations.....</b>	<b>73</b>
Week 12 Brainstorming Topics and Generating Questions .....	76
Week 13 Polishing Questions .....	82
Week 14 Background Research .....	93
Week 15 Background Research (continued) .....	96
Week 16 Hypothesis.....	98
Week 17 Investigation Design.....	100
Week 18 Investigation Design (continued).....	112
Week 19 Design Revision and Fair Forms.....	120
Week 20 Preliminary Data Collection.....	122
Week 21 Developing a Data Format and Display .....	126
<b>Stage 4: Conducting Investigations.....</b>	<b>131</b>
Week 22 Investigations Begin .....	133
Week 23 Abstract Lesson .....	135
Week 24 Transforming Investigations into Displays.....	139
Week 25 Work on Display Boards .....	144
Week 26 Analyzing Results.....	145
Week 27 Work Continues on Investigations and Displays .....	152
Week 28 Finish Displays.....	154
<b>Stage 5: Getting Presentations Ready for the Fair.....</b>	<b>156</b>
Week 29 Presentations .....	159
Week 30 Practice Presentations – Prepare for the Fair .....	163
Week 31 Final Fair Preparations .....	164
Week 32 The Fair!.....	165

## Notes on Lesson Formatting

Here is the general format for each week. Not all weeks will include each component.

**Week 99**  
**The Teacher Helicopter Ride**

**Overview** – Students construct a helicopter and the teacher rides it.

**Teacher to Teacher Background**

- Many teachers find the promise to ride the helicopter themselves motivating for the students

**Teacher Tasks Before the Session**

- You'll want to find your crash helmet.
- See if you can get a parent volunteer who has built a helicopter before.
- Make a copy of "Helicopter Assembly Steps" ♦ for students to use.

**Tasks During the Session**

- Be sure to provide good helicopter plans.
- *Are you sure that you put gas in the gas tank?*
- *Does someone have the number for the medics?*

**Teacher Tasks After the Session**

- From now on, you will be able to commute by helicopter. Send pictures to your Fair Director.

Brief title describing the week's goal

What you need to know before the session (content and pedagogical information)

This section gives details on how to prepare for the meeting (materials, etc.).

The ♦ tells you that there is a copy master or resource later in this week's section for you to use.

Activities and lessons are described here.

*A possible script for what you might say during a lesson is written in italics and indicated by this symbol:* 

Often, you will need to send off forms or contact volunteers in anticipation of upcoming weeks. This last section gives you a heads-up about those details.

 Web-based technology resources are provided throughout the curriculum to further extend and support student learning.

## Stage 1: Getting Ready

---

**At the beginning your energies are focused on laying the groundwork for your Science Fair program. This involves developing, with your school administrator, a plan for your students to do scientific inquiries (perhaps hold a school fair) and participate in the local Intel® ISEF Affiliated Science Fair. Most of the *Guide* in this stage is written for club model groups, but there are a few important points that classroom groups can adapt.**

If you are using these activities more than once a week, you should read the "TEACHER TASKS BEFORE THE SESSION" and "TEACHER TASKS AFTER THE SESSION" a few weeks ahead so you don't get caught short in organizing needed materials and arrangements.

### **Specific notes for specific situations:**

Using this *Guide* for classroom instruction

- Watch for notes which start "Class" they will help you with special adaptations for classroom use of this *Guide*.
- Much of the administrative checklist will not apply to your program, but it is still important to meet with your administrator about staging a school fair and your participation in the Intel® ISEF Affiliated Fair. It is important to get arrangements worked out early.
- You will use the Dr. Pepper\* and Mentos\* demonstration a few weeks later than the club groups.

Using this *Guide* for an after school club

- Watch for notes which start "Club:" They will alert you to special adaptation for use of this *Guide* in after school club situations.
- Remember, there are sample calendars for groups meeting two, three, and four times per week in Appendix B.

## Week 1

### Gearing Up

**Overview** – This week is all about preparation. You are meeting with your school administrator to plan.

#### Teacher to Teacher Background

- Read Section I of this *Guide* for basic information about the decisions you will need to make.
- Remember that while the tasks below may seem like a lot to accomplish, this front-load work will pay dividends in the long run. Your program will run much more smoothly with the groundwork firmly established.

#### Teacher Tasks

- Arrange a meeting with your administrator and begin reviewing “Administrative Discussion Checklist.”
- Club: Meet with your administrator to go over the checklist items and develop your school’s recruiting/selection plan.
- If you haven’t already, establish contact with your Fair Director. (See “Finding your Intel® ISEF Affiliated Fair”) Introduce yourself and ask any questions you might have. Note: You may already have had those questions answered at an organizational meeting with the Fair Director and other teachers, but continue to stay in touch with the Director!
- Club: If you will be forming a new school club and selecting students to participate, following the meeting with your administrator, begin getting a “Middle School Science Club Application” ready for distribution in Week 2.
- Inform your school’s volunteer coordinator (if you have one) that you will need science mentors (“Science Coaches”) and Science Fair Support Volunteers this year. Can this item be addressed during Back-To-School Night or piggy-backed on a form your school already uses to solicit volunteers? (See sample “Volunteer Recruitment Flier” ♦ and “Guidelines for Volunteers” ♦ )

#### Administrative Discussion Checklist

This week you will need to check your arrangements with your school administrator. Depending on the organization of your school, you’ll probably contact the principal or assistant principal. You want to be sure you have the go-ahead for your program and that your administrator understands what you will be doing.

Here is a checklist of topics to review with your administrator:

#### Club: Method of selecting students

*OK with administrator?*

Do a final check on your understanding and your administrator's understanding of which students will participate in your club.

#### Club: Information distribution at Back-to-School Night

*OK with administrator?*

One aspect of your student and volunteer recruitment effort may be to use your school's "Back-to-School Night" to spread the word about the Science Fair Program. You may want to make a quick presentation or to have a display and handouts. Be sure you have administrative approval.

#### Club: Information in school announcements

*OK with administrator?*

You may want to use your school's announcement system to get information to potential Club members. Your administrator needs to know if you plan to do this, when and how often.

#### Information in parent newsletter to recruit student members & volunteers

*OK with administrator?*  *And you know method of submission*

You also may want to make use of the school's parent newsletter to help recruit student Club members and volunteers. Find out how you can submit a few paragraphs and when the deadlines are. You also could use this avenue to publicize information about the Club's activities during the year and its participation in your Intel® ISEF Affiliated Fair. Again, be clear about your eligibility rules and why they are important.

#### Presentation to Parent Association?

*OK with administrator?*  *And you know whom to contact.*

In recruiting volunteers, you might want to make a brief presentation to the school's parent association or similar organization. If your administrator approves, he or she will tell you whom to contact and the timeline for such arrangements.

#### Help of volunteer coordinator

*OK with administrator?*

If your school has a volunteer coordinator, you will want to use this person to recruit various scientific mentors ("Science Coaches") and Science Fair Support Volunteers. Be sure your administrator knows that you plan to recruit through this coordinator.

## Transportation arrangements to your Affiliated Fair *OK with administrator* □

Students will need to be transported to your Affiliated Fair. Your administrator can help know of resources for funding buses or will be involved in approving other arrangements.

## Funding materials and fair fees. *OK with administrator* □

Students will need some investigation materials, display boards and fair fees funded. Your administrator will guide you in finding resources.

**Club: Here is a sample letter to parents about the Intel® ISEF Middle School Program used at one school:**

Intel & School Logo



You will want to specify details of your program in your letter. This is just a sample.

Date

Dear Woodside Middle School Parent:

As we begin an exciting new school year, I want to tell you about a new after school program, the Intel ISEF Science Club.

Intel Corporation has created this special science program, to allow more middle school students to explore science. During the program, students will participate in activities to learn about science, develop a science project, and compete for awards. On <date>, students will be invited to display their project at the <community, regional =or= state> affiliate of the Intel International Science and Engineering Fair, We will also sponsor a school community science expo, which will allow families to see the students' accomplishments.

The Intel ISEF Science Club will meet after school < fill in details>.

Please sign and return the attached permission slip, which allows your student to participate in the Intel Science Club, to be photographed and surveyed as part of the program. Return this permission slip to your child's teacher by (fill in DATE)

During the school year, we intend to provide you with additional information on the Intel Science Club and the Intel International Science and Engineering Fair. I think the Intel Science Club will be a positive experience for our students and our school community. If you have any questions, please feel free to contact me by calling...

Best regards,

PRINCIPAL

Enc: permission slips



## Sample Volunteer Recruitment Flyer

This year our school will be organizing a Science Fair Program for students. Our students will then present their projects at an Affiliated Intel® International Science and Engineering Fair in the spring.

Students meet after school for about an hour (=or= Students work in their regular science classes.) Volunteer help is needed in many ways. We need people in the science, medical or engineering professions to act as “science coaches” and mentors to our student scientists as well as people with clerical, organizational, and/or presentation (public speaking) skills. We need many people who will listen to our students explain their work. No previous experience with science fairs is necessary!

Please contact if you are able to assist us in any way.

Thank you! Your help is much appreciated.

**You will want to specify details of your program in your letter.**

**This is just a sample.**



The Intel International Science and Engineering Fair (Intel ISEF) is a worldwide program for student scientists and engineers at the high school level. Each year about 1200 finalists from 53 countries for the final competition.

Locally, the <supply name> Science fair held in <city> is the <community =or= regional =or= state> affiliate of the Intel ISEF. Finalists from this fair go to the international competition.

The Intel ISEF Middle School Program is intended to support middle school students in inquiry activities which will expose students to research methodology, inquiry-based learning activities, science careers and science mentors. Students are offered hands-on opportunities to learn about science fairs, develop a science project, and to compete for awards. Our students will participate in the Middle School portion of the <supply name> Science fair this spring .

## Guidelines for Volunteers

(A guideline on expectations for your Science Coaches and Science Fair Support Volunteers should be handed to them prior to their first visit to the classroom. Modify and add any of your school's policies to this list.)

Make sure you know and understand the school's policy about volunteers working with students and follow it. (e.g., Are you expected to check in at school office? Do you have to wear a visitor/volunteer nametag while in the school building?) Talk to the science teacher if you have any questions.

- Student confidentiality: Anything the student discusses with you should remain confidential. If something concerns you, raise it only with the teacher or school administrator. They will decide on any necessary action.
- Do not allow yourself to be alone in a closed room with a student. Always have a third person present. It's best to work in an open or community area.
- Avoid talking specifics about the student with their parents. This is the teacher's responsibility, and any comments or questions should be directed there. General positive comments are fine, however.
- Please be sensitive to and respectful of the diverse cultural backgrounds from which students may come.
- While it may seem helpful for a volunteer to want to assist a student outside school hours, *volunteers must not arrange to meet any student at times or locations other than the class or Club meetings* without prior approval of the teacher and/or administrator and parents.
- Be sure the investigation and display is the student's own work. Advising and coaching are appropriate. Becoming a co-investigator with the student is not.

## Week 2

### Club: Publicize Science Fair Program/Students Apply

**Overview** – Students learn about the Science Club through inquiry science presentations and other publicity methods and begin applying for Club membership.

#### Teacher to Teacher Background

- Depending upon your school's recruiting/selection process that you developed with your administrator, you may be heavily promoting the Club this week via student announcements, newsletters and/or this motivational mini-investigation demonstrated in science classes.

#### Teacher Tasks This Session

- Arrange for science teachers or volunteers to conduct the "Dr. Pepper\* and Mentos\* Demonstration" in science classes (or at other convenient times) to get students thinking about whether they want to participate in more of these kinds of investigations in an after-school Science Club. Give a copy of the demonstration procedures to those who will be conducting it.
- Gather enough materials for each scheduled demonstration. (See "Dr. Pepper\* and Mentos\* Demonstration" for materials list.) Remember, students are going to want to see it more than once!
- Club: Make informal posters or handouts listing your Club's eligibility requirements. Give copies to those conducting the demonstration to show to students when talking about Club membership.
- Club: Make sure you have a plan for how students are to submit their Club applications and when/how they can expect to hear back about their acceptance.
- You also may be finishing up tasks from Week 1 right now.

## Club Version: Dr. Pepper\* and Mentos\* Demonstration

### Background Notes

- One way to stir a student's imagination and get them thinking scientifically is by performing a science demonstration and asking questions along the way. The following demonstration can be used to show the steps of the inquiry process and spark students' interest in doing more such investigations.
- **Cautions about the Dr. Pepper\* and Mentos\* demonstration:** Try to develop the drama about what is going to happen. The whole demonstration is quite safe and dramatic, but very, very messy. Be prepared for the all of the Dr. Pepper to wind up on the ground outside the bottle. This demonstration should only be done outside. Have students standing at *least* four feet from the bottle and ready to back up. Make sure the runoff will go someplace where it won't cause trouble. Once you start the chemical reaction, get yourself out of the way!

### Tasks Before the Demonstration

- Assemble for *each* demonstration (you may want to repeat this more than once):
  - 1 two-liter bottle of Dr. Pepper
  - Four cinnamon Mentos candies
- Practice the demonstration once or twice with a group of friends or family. (See "Cautions" in Background Notes above.)
- Be ready to repeat the demonstration for the students if they want to see it again.

### Tasks During the Demonstration

- Start by taking students outside and doing the Dr. Pepper and Mentos demonstration. (See "Cautions" in Background Notes above before performing this demonstration.)
- Procedure for the demonstration:
  - Have available a two-liter bottle of Dr. Pepper and a package of cinnamon Mentos candies. As you carry the Dr. Pepper outside, avoid shaking the bottle in any way.
  - Set the bottle on the ground and gently take off cap, still avoiding agitating the contents.
  - Hold four Mentos candies in your hand so that they are lined up and can be *quickly* dropped down the neck of the bottle.
  - Without lifting the bottle off of the ground, slide the candies into the open top of the bottle.
  - Stand back!
- While still outside, and after the commotion settles among students, ask,



*So, if you were doing a project based on this, what kinds of questions would*

*you try to answer?*

- Allow the students to tell you a few. Then ask,



*If I wanted to know if the type of candy used had an effect, what could I do? For example, if I had a package of Wintergreen Life Savers\*, a package of Mentos and a bottle of Dr. Pepper ready, how could I set up that investigation? What would I do?*

- Let students tell you some procedures – they should be brief and simple.



*If I used different candies, could I use a whole bunch of Life Savers and compare those results to results of the experiment with only four Mentos? Why or why not?*

- Let them tell you to use either the same number of candies or the same weight.



*What could I look at if I wanted to compare the effect the Life Savers had on the pop with the effect the Mentos had on it?*

- Students might say to look at how high the foam shoots out of the bottle or at how much liquid is left in the bottle afterwards.



*You could write down the results for all your different trials and then find out the answer to your question about the effects of using different types of candy.*

*Our school is forming an after-school club that will meet to do investigations like this. Each member also will do an investigation for the big science fair this spring held at \_\_\_\_\_.*

*If you are interested in being part of the Club, doing your own investigation and going to the <community =or= regional =or= state> International Science and Engineering Fair with us in the spring, take a look at the application. See if you meet the eligibility requirements, and if you do, fill out the form and turn it in by \_\_\_\_\_.*

- You can repeat the demonstration if you like, and then return the students to the classroom.

### Tasks After the Demonstration

- (If you will be selecting participants for your club) Once inside the classroom, talk about the Science Club's eligibility requirements.
- Answer any questions about Science Club. Pass out applications and let students know the when/where/how of returning them and when/how they'll be notified of Club membership.

## Week 3

### Club: Selection and Notification of New Members

**Overview** – Teachers select and notify Science Club members this week.

#### Teacher Background

If your club must be selective in membership, and if some students are not selected for the Science Club, it may be a difficult week for them. It can help to have alternative places to which you can direct them where they can pursue their interest in science outside the classroom. Does your community have a zoo, science museum, planetarium or arboretum that offers classes or needs student volunteers? Are there science summer camps in your area? Perhaps your school has an alternative science program for non-eligible students?

#### Teacher Tasks

If your club must be selective in membership:

- Select students according to your Recruiting/Selection plan. Inform your administrator of the new Science Club members.
- Send letters to all accepted and non-accepted applicants.

Read ahead for materials you will need to gather for the Week 7 activity. You'll probably want friends to save coffee cans and plastic lids for you.

## Stage 2: Learning Through Group Investigations

---

The meetings in this section give students a quick overview of and initial experience with the inquiry process and vocabulary. Specific skills and terms mentioned in this stage will be reinforced and taught in more depth within the context of the students' own investigations in Stage 3.

If you are using these activities more than once a week, you should read the "TEACHER TASKS BEFORE THE SESSION" and "TEACHER TASKS AFTER THE SESSION" a few weeks ahead so you don't get caught short in organizing needed materials and arrangements.

Specific notes for specific situations:

**Using this *Guide* for classroom instruction**

Watch for notes which start "Class" they will help you with special adaptations for classroom use of this *Guide*.

**Using this *Guide* for an after school club**

Watch for notes which start "Club" They will alert you to special adaptation for use of this *Guide* in after school club situations.

## Week 4

### First Science Group Investigation

**Overview** – Students spend time building group dynamics and participating in a mini-investigation.



Additional inquiry-based classroom science investigations can be found on the [Science Buddies](#) website.

#### Teacher to Teacher Background

- **Class:** These initial activities are designed to introduce students to each other and allow you time to observe them together. You will already see your leaders emerging. Use them in your group as role models and helpers when appropriate.
- The candle demonstration described below pulls students into thinking about science in an interesting and sometimes surprising way. Try to encourage them to use well thought-out, detailed observations; to become comfortable with terms like *variable*; and to think broadly regarding possibilities to test their theories.
- Your role is to encourage student observations and to draw out more detail and variety in the students' observational skills.

#### Teacher Tasks Before the Session

- **Club:** Inform selected students of the Club's first meeting date, time and place. Students may need to arrange their own transportation home from this first meeting.
- **Club:** Purchase and organize the distribution of snacks. When you go to the store, buy for several weeks.
- Assemble materials needed for this week's meeting:
  - Four tennis (or similar sized) balls
  - One small tea candle for each student
  - A book of matches for each student
  - A cup of water for each student
- Practice the demonstration ahead of time prior to doing it with students.
- **Club:** Remind students of the first meeting. Talk it up! Inform students that no-shows may be asked to leave the Club.

#### Tasks During the Session

- **Club:** SNACK
- **Club:** While students are arriving, introduce yourself, welcome them, point them towards the snacks and encourage them to sit in a circle.



### **Club: Activity #1: Getting to Know You**

After they've devoured their snacks, it's time to head outside. Have students stand in a small circle almost touching shoulders. Go around the circle asking everyone to share their name. Hand the tennis ball to one student and explain the game. Students are to toss the ball to another student (not one right next to them) and say that student's name as they toss it. The second student tosses to another student and so on until all students have touched the ball. Do it again, encouraging the students to pass to someone new and to try to go faster. Once the group seems to be learning names and doing well together, introduce a second ball and let the game continue for one minute. Challenge the group to toss without dropping the ball for one, then two full minutes.

### **Club: Activity #2: Problem Solving**

Break the large group into smaller teams of 5-6 students. Explain the task has changed. Now you are giving them a chance to show their problem solving skills. The small groups will work as a team to race against the others. Have the students stand an arm's length apart. The task is to pass the ball to each person in the team. No names have to be spoken. It is a race. Say, "Go" and see what happens. Some teams will quickly realize they can move closer, some will look at others and "steal" ideas on how to get faster. Either way, they are working and laughing together and getting to know each other. Continue the races three or four times before discussing some of the problem-solving strategies the group used to become faster. Relate this thinking process to the concept of inquiry and the problem solving they will be doing in the club. When finished, return to the classroom.

### **Class: Activity: Dr. Pepper and Mentos**

Your group will be involved in the demonstration previously outlined for clubs. The "Class Version" starts on the next page.

## Class Version : Dr. Pepper\* and Mentos\* Demonstration

### Background Notes

- One way to stir a student's imagination and get them thinking scientifically is by performing a science demonstration and asking questions along the way. The following demonstration can be used to show the steps of the inquiry process and spark students' interest in doing more such investigations.
- **Cautions about the Dr. Pepper\* and Mentos\* demonstration:** Try to develop the drama about what is going to happen. The whole demonstration is quite safe and dramatic, but very, very messy. Be prepared for the all of the Dr. Pepper to wind up on the ground outside the bottle. This demonstration should only be done outside. Have students standing *at least* four feet from the bottle and ready to back up. Make sure the runoff will go someplace where it won't cause trouble. Once you start the chemical reaction, get yourself out of the way!

### Tasks Before the Demonstration

- Assemble for *each* demonstration (you may want to repeat this more than once):
  - 1 two-liter bottle of Dr. Pepper
  - Four cinnamon Mentos candies
- Practice the demonstration once or twice with a group of friends or family. (See "Cautions" in Background Notes above)
- Be ready to repeat the demonstration for the students if they want to see it again.

### Tasks During the Demonstration

- Start by taking students outside and doing the Dr. Pepper and Mentos demonstration. (See "Cautions" in Background Notes above before performing this demonstration)
- Procedure for the demonstration:
  - Have available a two-liter bottle of Dr. Pepper and a package of cinnamon Mentos candies. As you carry the Dr. Pepper outside, avoid shaking the bottle in any way.
  - Set the bottle on the ground and gently take off cap, still avoiding agitating the contents.
  - Hold four Mentos candies in your hand so that they are lined up and can be quickly dropped down the neck of the bottle.
  - Without lifting the bottle off of the ground, slide the candies into the open top of the bottle.
  - Stand back!
- While still outside, and after the commotion settles among students, ask,



*So, if you were doing a project based on this, what kinds of questions would*

*you try to answer?*

- Allow the students to tell you a few. Then ask,



*If I wanted to know if the type of candy used had an effect, what could I do? For example, if I had a package of Wintergreen Life Savers, a package of Mentos and a bottle of Dr. Pepper ready, how could I set up that investigation? What would I do?*

- Let students tell you some procedures – they should be brief and simple.



*If I used different candies, could I use a whole bunch of Life Savers and compare those results to results of the experiment with only four Mentos? Why or why not?*

- Let them tell you to use either the same number of candies or the same weight.



*What could I look at if I wanted to compare the effect the Life Savers had on the pop with the effect the Mentos had on it?*

- Students might say to look at how high the foam shoots out of the bottle or at how much liquid is left in the bottle afterwards.

*You could write down the results for all your different trials and then find out the answer to your question about the effects of using different types of candy.*



*We are going to work in our class on investigations like this. Each of you will do an investigation for a big regional science fair in the spring.*

- You can repeat the demonstration if you like, and then return the students to the classroom.

### Activity 3: Magic Candle Demonstration

- Ask students how and why candles light. You will show them a new technique and discuss why it happens. Your focus is not, however, on why it happens as much as what additional tests or inquiry can be done with the demonstration to test variables. Begin now to use terminology, like *variable*, that you want the students to develop.
  - Light the candle with a regular match.
  - Blow out the match.
  - Light a second match and hold it close to the lit candle.
  - Blow out the candle and quickly hold the flame (of the lit match) in the smoke of the candle's wick. The smoke will carry the flame to the wick and it will light.



*What just happened? What questions do you have about what you just saw?*

- Possible questions students might generate:
  - Will a longer wick (variable) create a longer stream of smoke?
  - How much time (variable) can you let lapse before it will light?
  - How far away (variable) can lit match actually be to get the smoke to catch fire?
- If time and your school's safety rules permit, let the students — under close supervision — experiment with tea candles and matches on their own.
- Make sure ample time is left for clean up and reminders for next week's meeting.

### Teacher Tasks After the Session

- Club: *No-show students* – If selected students did not attend the meeting today, make sure you contact them tomorrow (send a message through one of their teachers if you can't see them personally) to find out if they are still interested in joining the Club. If not, invite another student for next week's meeting.

#### Safety Tips

The Magic Candle activity requires special safety precautions. Remove all papers and other flammable items from demonstration area and have a fire extinguisher handy. Tell students it is a good demonstration for the purpose of today's lesson, but that their Fair projects will not involve fire.

Do not try to actually measure the distance that you can make the flame jump back to the candle. Such attempts usually result in a scorched ruler or burned teacher.

Be sure to use "tea candles," which come in a metal dish about 1 1/4" in diameter and 1/2" high. Such short, broad-based candles will not tip over easily.

## Week 5

### Introduction to Science Inquiry: Cars & Ramps

**Overview** – Students conduct a quick inquiry investigation and then receive a very brief overview of the program.



Additional inquiry-based classroom science investigations can be found on the [Discovery Education](#) website.

#### Teacher to Teacher Background

- This week you will give your students a very brief overview of inquiry. The overview is meant to generate student excitement more than it is meant to provide them with details of the program.
- Through a quick, hands-on experience, students will see all the components of the inquiry process. If students are not experienced with doing investigations, they may be dependent on you to provide details of experimental procedure. Start now encouraging them to design for themselves. In fact, much of your job all year will be to encourage students to believe that they have the answers and ideas they need inside themselves.
- In our experience, work groups larger than pairs often have someone left out of the experience. The cars and ramps investigation usually engages groups of two or three. It was selected partly because a student can't do it alone. Success depends on working with others. Cultural differences might predispose some students to be passive. Encourage everyone to realize that each student brings something to the process.

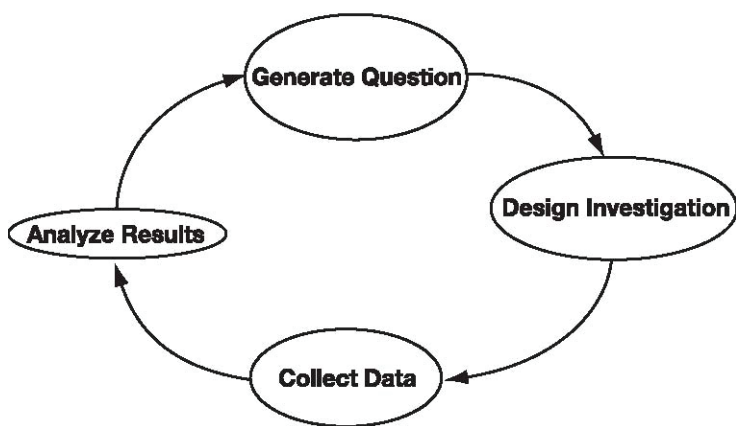

Here is one four-part model of the steps of scientific inquiry.

If your students are familiar with another model that uses different vocabulary, use that instead for the investigations.

- Another way to look at the process is covered on the next page. These notes are primarily for you as a teacher, although we have also included them as a student resource ♦ that you could use with students. If you do, you'll probably need to spend extra time explaining the notes in student language.

## Notes on the Four Step Inquiry Model *(with additional notes for teachers)*

The student <b>Develops an inquiry question</b>	The student <b>Designs an investigation</b>	The student <b>Gathers and transforms data</b>	The student <b>Prepares an analysis</b>
Do Background Research  <i>See Week 15</i>	Write Clear Procedures  <i>See Week 6 &amp; Week 17</i>	Plan Data Records  <i>See Week 21</i>	Identify patterns in results accurately  <i>See Week 26</i>
What is an "Inquiry Question"  <i>See Week 5, Week 7, Week 8, Week 12, and Week 13</i>	State Protocols (rules for repeatability and dealing with anomalies.)  <i>See Week 17</i>	Do a transformation that helps answer the question  <i>See Week 21</i>	Explicitly use results to answer the question  <i>See Week 26</i>
Use Operational Definitions (Clarifying the question)  <i>See Week 17</i>	Use concept of "fair test"		Discuss sources of error and limitations  <i>See Week 26</i>
<b>A great question foreshadows a good design</b>	<b>A great design leads to easy data gathering</b>	<b>A great data presentation makes the analysis leap out.</b>	

The experience of most science inquiry teachers is that the whole project never gets better than the quality of the question. It needs to be clear. It needs to be a question that can be answered by the student gathering data and analyzing it. It needs to easily lead the student toward a procedure.

## Notes on the Four Step Inquiry Model

The student <b>Develops an inquiry question</b>	The student <b>Designs an investigation</b>	The student <b>Gathers and transforms data</b>	The student <b>Prepares an analysis</b>
Do Background Research	Write Clear Procedures	Plan Data Records	Identify patterns in results accurately
What is an "Inquiry Question"	State Protocols (rules for repeatability and dealing with anomalies.)	Do a transformation that helps answer the question	Explicitly use results to answer the question
Use Operational Definitions (Clarifying the question)	Use concept of "fair test"		Discuss sources of error and limitations
<b>A great question foreshadows a good design</b>	<b>A great design leads to easy data gathering</b>	<b>A great data presentation makes the analysis leap out.</b>	

- Students doing investigations (especially for the first time) will seem to take more time than those doing “cook book” experiments from science books. Require safe and respectful behavior, but give them time to explore. Such exploration will help them with their design and analysis as they work through the inquiry process. They may not be familiar with on-task but divergent thinking.

## Teacher Tasks Before the Session

- NOTE: You will need a “cars and ramps set-up” for every two or three students. (See [Teacher to Teacher Background](#) above on group size.)
- Assemble enough of the following in a central location (not set up in stations):
  - ramps of cardboard, 3/8”plywood or similar material. (Ramps can measure about 12” x 24,” but keep all of them uniform.
  - 3 to 5 cars per group (they do not have to be identical) - Matchbox™ cars work well.
  - one per group - meter stick or measuring tape at least 20’ long
  - masking tape (Most groups will mark start points, some will mark finishes and not take measurements. Some groups will choose to mark the finish points with tape and others may start to measure distances.)

NOTE: This variety in their approaches makes wonderful discussion fodder for later. Take pictures if you can!
  - three identically sized books for each group - However, all groups don’t need the same three. Classroom sets of text books are ideal.
  - paper and pencils to write data on and to take notes
  - one teacher note pad for you to record observations of students
  - [Optional] – camera for recording students in action – best if digital.
  - [Not Optional] at least one enthusiastic, encouraging and energizing adult!
- Set up a model ramp on the floor with two books supporting the upper end of the ramp and the rest of the ramp extending to the floor. Pre-select two cars that have different success rolling off the ramp; have these available for your demo.
- If needed, print and distribute your school’s parent permission slips for the movie, *October Sky*, which we suggest using a clip from at the next meeting.



## Tasks During the Session

*(Suggested teacher words are in italic)*

### QUICK DEMONSTRATION (10 MINUTES MAX.)

- After the students have gathered and settled, conduct a brief demonstration on the use of the cars and ramps. Use the model ramp you've set up.



*If you look over here, you'll see what we are going to do today. I want you to work in groups of two or three people to work out a way of finding out which car goes down the ramp best. Watch. (NOTE: You purposely are not defining what you mean by "goes down the ramp best." That vagueness is intentional right now.)*

- Simultaneously release two cars down the model ramp and allow them to run out onto the floor. If they tie, just pick up the cars and repeat the trial.



*See, one goes better. Now I want you to figure out a procedure to give each of your cars a "fair test" to find out which car goes down the ramp best. Later, we'll want to hear two things from your group: your procedure and which car you think goes best.*

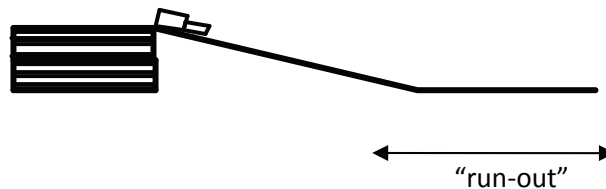

- Don't explain too much. As mentioned above, you are leaving undefined terms like "goes down the ramp best." Don't introduce the term "run-out." If students start measuring or marking something like run-out, then use the term with that group. However, do be sure to use the term "fair test" with all the groups. Later, this will lead to students discussing the idea of controlling variables.



*Let me show you what you have to work with. Each group should get a ramp and some books and about 4 cars. I've also put some other things on the supply table that you might want to use. There are meter sticks (or measuring tapes), some masking tape and some paper and pencils.*

- Casually assign students to groups.



*Why don't you three work as a group, and, you three, and you three and you two... [etc.] - - O.K., let's get to work.*

If you are a highly organized teacher, it may be hard for you to not give detailed instructions about how to conduct the investigation.

Resist the temptation to intervene with suggestions. Let them learn more vividly from their own experience than from your words.

### STUDENT WORK TIME (30 MINUTES)

- While the students are working, listen and, if possible, make notes on how they come to agreements on their “rules for a fair test” of a car. Note the following for later discussion:
  - how they make an effort to control some variables;
  - the rules they make up to decide whether or not to “count” an unusual trial (for example, car falling off the side of the ramp);
  - if any groups decide to do multiple trials for each car and then average results;
  - how they refine your purposely vague question; and
  - if any students write down data. (When they report results, also note how some groups back up claims of “the red car went best” with data.)
- If you have a camera, take a few pictures of the students working. Photograph them starting their cars and measuring or marking the stopping points of the cars. If you show identifiable images of students, you will want to be sure to follow your District’s policy on photo releases.
- Blend into the woodwork while the students solve their own problems of experimental design. After they’ve had some time to explore and once they’ve begun to run some trials, ask if they are writing down their procedure. Suggest they do so. If you hear something like, “Always put the front on this line” ask them to write that rule down. If they “throw out” a trial or decide that one doesn’t count, ask them to write down the rule for which trials will count. If a group decides to run each car three times, ask them to write that rule down. Include these observations in the notes for yourself so you can call on these students for examples later.
- Let this go on for awhile. Then focus the students on recording their step-by-step procedure and any rules they might have for “a fair test.”

### BACK TO LARGE GROUP (10 MINUTES)

- Bring them back to a large group. (Club: You might have snack now during discussion.) In order that you can refer to this again in a few weeks, on a butcher paper sheet begin to generate:
  - a record of how students clarified the term “goes down the ramp best” - How did each group define that phrase? Point out to students that there are different ways to define “best” in this instance.
  - any procedures and “rules for a fair test” students used

- Continue your discussion until about 10 minutes before ending time. You'll come back to this topic at your next meeting.

OVERVIEW (more emphasis right now on *enthusiasm* than details) (10 MINUTES)

Plan to say something such as:



*CLUB: I'd like to let you know what we are going to do in the Club. We'll have a meeting once a week where we do science activities like the one we did today. At first, we will all work on the same thin., But later in the year, we'll help you work on your own project. We'll have a number of adults to help you figure out what you want to experiment on and how.*

*CLASS: We'll be spending the next few weeks learning about how scientists do research. Each of you will be developing a Science Fair project. At first, we will all work on the same thing. But later, we'll help you work on your own project. We'll have a number of adults to help you figure out what you want to experiment on and how.*

*ALL: This spring, you'll turn your own investigation project into a display, and we'll all take our displays to the <community =or= regional =or=state> Science Fair*

## Teacher Tasks After the Session

- At the end of the lesson, save the butcher paper sheet of the students' rules and each group's individual write-up of their procedures. You'll need these next week.

## Week 6

### Writing Procedures

**Overview** – Students discuss last session’s Cars and Ramps investigation as they learn about writing procedures and establishing protocols for experiments.



Additional sample procedures and protocols can be found on the [All Science Fair Projects](#) website.

#### Teacher to Teacher Background

Part of doing an investigation is writing-up the procedure. Scientists write procedures to ensure accurate data that can be replicated by someone else doing the same experiment. Middle school students, who are still developing their descriptive writing skills, may have great difficulty including the necessary detail in their procedure write-ups and will need quite a bit of guidance in this area. It is useful to

Middle school students we interviewed at their science fair told us that writing the procedure was the hardest part of the whole project.

Help them with this lesson before you have them work individually on their own projects.

have them include diagrams as part of their procedure when they get to that step in later weeks. Also, you’ll find that as the students begin to work on procedures, they’ll experience unexpected challenges that often lead them to include more specific details, or “rules,” of the experiment. This *Guide* refers to these details as protocols. For example, in last

week’s Cars and Ramps Activity, students probably had a protocol for what to do if their car rolled off the ramp.

#### Teacher Tasks Before the Session

- Gather the butcher paper sheet of students’ procedures and each group’s individual procedural write-ups from last week’s Cars and Ramps Activity. You’ll use them today.
- Write some purposefully vague instructions (see box) on the whiteboard about how to open a combination lock. Have such a lock on hand for the meeting.

#### Tasks During the Session

- As the students come in, refer them to the whiteboard where they should find errors or items missing from the lock procedure as written. Focus their thinking on details, details, details. Also, discuss the value of drawing diagrams to accompany procedures.

#### *Vague Instructions for*

#### **How to open a combination lock**

- Turn the dial three times to each of the numbers.
- Pull.

### INTRODUCTION TO PROCEDURE/PROTOCOL (10 MINUTES)

- Ask someone to act out the instructions exactly as they are written on the whiteboard, and have another student write in the missing steps as the students discover them.
- Once students begin to include missing steps, ask:
- What if the lock breaks? What if my arm is bumped while I am turning the lock? What do I do if I accidentally spin the wrong way? Special rules on what to do in these situations are called “protocols.” Did you have any protocols in your Cars and Ramps write-ups from last week?

### PROCEDURE ANALYSIS (40 MINUTES)

- After discussing the details of the lock instructions, have groups examine procedures and rules generated on the butcher paper sheet from last week. Have students reassemble in their groups and give them back their written procedures.
- Do you want to revise these now to make them more user-friendly? Could a neighboring group answer your question with the directions as you have them written?
- Have groups work on revisions and then swap with another group. Give them about five minutes with a procedure before having them trade again. Do this about four times. Finish by having the original writers of the procedure examine theirs and if time, write a new one. If students did not include pictures, have them do so now.
- As the groups are reviewing, walk around the room encouraging the students to think through and even pretend they are doing the procedure just as stated. If there is time, have them pick one of procedures and try it out. Have them write down the places they get stuck or don’t know what to do.

### WRAP-UP (5-10 MINUTES)

- Bring the group back together and review some main principles of the day:
  - Procedures must be detailed
  - Include in your procedures specific rules (protocols) for unexpected events or uncontrollable ones
  - Draw pictures

## Teacher Tasks After the Session

- Once again, save butcher paper sheet from Cars and Ramps investigation.
- Save groups' edited Cars and Ramps procedures. They may be referring to them later.
- Be sure you have materials you will need for the Week 7 Activity. You'll probably want friends to save coffee cans and plastic lids for you.

## Week 7

### Group Investigation: Comeback Can Activity

**Overview** – Students view other inquiry science fair project display boards and hear more about the upcoming Fair before experimenting with “Comeback Cans.”

#### Teacher to Teacher Background

- Since you formally introduce the concept of a science fair today, some students may already be thinking about the experiment they want to do. Some also may be considering working with a partner.
- NOTE: We have found that students working alone or in groups of two work best. Groups of three or more don't seem to be as effective, and students in larger groups do not equally share in the work. We strongly recommend you not allow groups of more than two. Each student must be knowledgeable about all aspects of his/her project.
- The movie, *October Sky* [Universal Studios, 1999 - rated PG] is a wonderful movie to demonstrate the fact that persistence and perseverance through difficult times pay off in reaching a scientific goal. A clip from that movie is shown in the group meeting today to get students excited about their experience at the Fair.

#### Teacher Tasks Before the Session

- Try to gather a few science fair project display boards from other science teachers or your Fair Director to show to your group members. Teachers usually keep a few to show future classes. Try to gather a range of quality so students can see both good and poor presentations. If you can't find any in your building, try a high school teacher in your district.
- Rent the movie, *October Sky*. Preview at home to determine the part(s) you want to show. We recommend the portion about 70 minutes into the film.
- Gather the following materials for each pair or trio of students:



You can generate student excitement about science fairs by showing them examples of inquiry science fair competitions!

[Discovery Channel Young Scientist Challenge](#)

[Google Science Fair](#)

- 1 empty coffee can (open both ends)
- 2 plastic lids for the coffee cans
- Weights for each can - nuts or washers totaling about 40 grams (about an ounce and a half, which is the weight of eight U.S. 5-cent coins; [large nuts may work better])
- 2 popsicle sticks, toothpicks or paper clips
- rubber band (see diagram to get an idea of the length and size.)

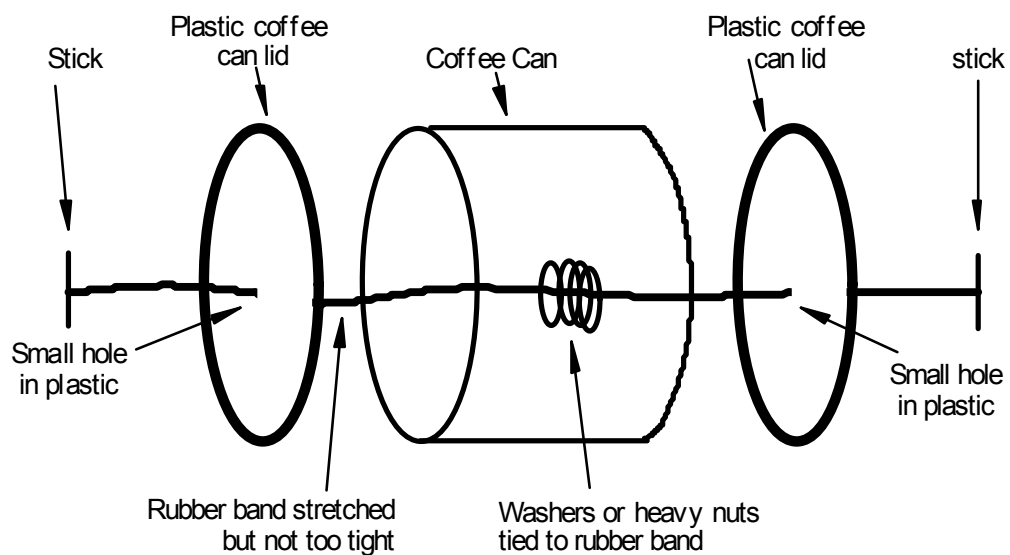

- Assemble all this into a set-up as shown in the diagram, but using only about 2/3 of the washer/nut weights inside. Have the other weights available to the group if they decide to add more weight to the can later.
- Make sure you have the weight(s) tied to the rubber band so that when the weight flips as the can rolls, the rubber band is wound up. If the weight is not tied on tightly, the weight will just roll over and over without winding up the rubber band.
- Our research with this activity has shown that smaller cans work better than large ones.
- The size of the weights being used has to increase with the size of the can.



- Use a heavier weight than you think you need. Your results for demonstration will be better.
- Instead of using one or two rubber bands and stretching them through the can, you can use one long rubber band. Thread the long rubber band through one end, through the weight and back to the lid of the can. Then you can tie it off. This makes experimenting with the tension of the rubber band much more manageable.
- Above all, keep trying and experimenting. This does work!!

## Tasks During the Session

### PREVIEW PATH TO THE FAIR (30 MINUTES)

- Remind students of their final goal: they are going to present their own investigation and its results in a competitive fair. The students may have questions, and now is a good time to focus their thinking on the path to the fair. Try to alleviate any nervous feelings by assuring them of your assistance along the way.
- Next, show a short a clip from *October Sky*, beginning approximately 70 minutes into the movie. (It shows the boys' success in launching their rocket and their attendance at a regional science fair.) The purpose of showing the clip is to give students some idea of a science fair atmosphere. Answer any questions afterward.

### "COMEBACK CAN" ACTIVITY / PREPARATION FOR SCIENCE INQUIRY NIGHT (30 MINUTES)

- Begin the "Comeback Can" demonstration by showing the students the coffee can set-up. Show them how the inside is configured. Next, roll the can so it runs out and comes back. Ask:



*How can I get this coffee can to roll out the furthest it's able to go and still come back?*

- Students may say to send it rolling out fast, with a big push. Others might suggest adding more weight inside or tightening the rubber band. (Have replacements on hand.)

It's now the students' turn to try this. Informally assign groups and have areas set up so students can spread out, perhaps on the floor. Encourage students to try out different changes in the set-up or procedure to maximize the run-out distance.

- After the fun of running the cans, discuss with the students what they just did and note any rules and observations they come up with.

- Ask questions:



*What changes mattered in how far the can rolled out before coming back to you? (Label these as “variables.”)*

*How can you show this? (Introduce the idea of changing, controlling and measuring variables.)*

- Explain that to show the effect of one variable (e.g., the weight of nuts or washers in the can), you change it while holding all other variables (e.g., where you start can from, type of can, type of rubber band, etc.) constant.

(For the teacher: In scientific language, you change the independent variable you are investigating while holding control variables as constant as possible and measuring the effect in the dependent variable. The Glossary [Appendix A] discusses these terms.)

- Students may come up with other changes/things they want to vary (variables) during this activity.
  - NOTE: The questions/changes they generate are possibilities for what they might demonstrate and ask their parents to test next week at Science Inquiry Night. Now is a good time to ask for volunteers to man different investigation stations during that night. Some students will want to show the different tests done in the Cars and Ramps experiments, and others will want to demonstrate the “Comeback Can” activity. It is best if these assignments are agreed upon now, so everyone knows what to do on that night.

## Teacher Tasks After the Session

RELAX!

## Week 8

### More Group Investigations

**Overview** – In this session you will choose from a number of investigations to do with your students. These all focus students on developing inquiry questions from common group experiences. Based on your assessment of their skill level, you will do one or more of these.

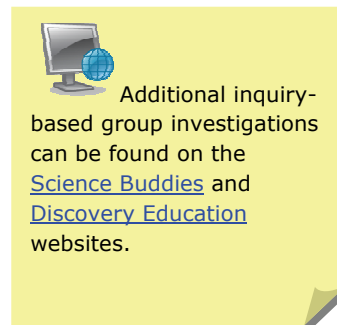

#### Teacher to Teacher Background

- This is a very important step. Your students must be able to independently develop inquiry questions before they are given the task of working on their own topics and projects. It may take two or three or more activities for your students to be ready. We've provided a list of sample inquiry questions associated with each of the group investigations. These are not intended to be used with students. They are to let you know the kinds of questions your students will generate spontaneously when they are ready to proceed to developing inquiry on their own.

One teacher put it this way:

"Spend time now developing inquiry questioning skills in students or spend weeks trying to help frustrated students salvage projects that have a poor foundation."

- It is very easy to want to move students along toward working on their own science fair investigation. Resist this urge. This is the time to develop skills that will help students to success. Don't rush through this.

#### Tasks During The Session

- You will need to assemble materials for the activities you choose and you should be prepared to allow students to repeat activities, or do other activities until their skill has developed sufficiently. Over prepare for today. Continue to do group investigations until you think your students can ask questions such as those listed below the activities *on their own*.
- Let the students explore the activity for a sufficient time so that they can come back to a large group setting and discuss inquiry questions which could be investigated. The students do not need to complete the entire activity, just get enough of a feel for it to generate questions.
- Lead the group in discussion and listing possible inquiry questions. You might want to make the list on a poster. Press them for more ideas. Your leadership will need to be fairly strong at first and you might even have to

offer some examples, but as soon as you can, reduce your profile so students are generating questions as much as possible. In later stages, you will want to see that everyone in the group has had a chance to offer questions.

- Listed below are half a dozen simple investigations you can offer your group. Do one and listen to the level of questions offered. Are they inquiry questions? Can the students tell you what they would measure and what they would control? Are all students able to come up with ideas or are only a few students carrying the discussion? If some of your answers to these questions are still negative, add more group investigations.

## Simple Group Investigations

### 1. Balsa Wood Airplanes

<b>Where</b>	Outside or in a long deserted hallway
<b>Equipment at the station</b>	Three to five balsa wood airplanes of various designs
<b>Warehouse equipment</b> (things the students can use in their investigation if they think of needing them)	long measuring tapes masking tape paperclips for weights rubber bands for weights a balance for weighing the planes or weights added
<b>Demonstration</b> Show how the wings and tail features of the airplanes can be moved and throw one. Ask what the important variables might be and what questions come up. Don't answer any but challenge the students to explore and develop investigation questions.  If this is will not be a student conducted activity, take suggestions for manipulating the plane (move wings, add weight, move tail etc.) and throw it each time. Until directed otherwise, throw sometimes with obviously different force and different stances.	

### 2. Pendulums – Small or Large

<b>Where</b>	Lab demonstration stand on a sturdy table or with a string (rope?) hung from a ceiling hook or tree.
<b>Equipment at the station</b>	A way to adjust the length of the pendulum and a way to add weight (up to double the starting weight will be good)
<b>Warehouse equipment</b> (things the students can use in their investigation if they think of needing them)	measuring tape weights more string or rope a balance for weighing weight of pendulum stopwatch clock in room
<b>Demonstration</b> Start the pendulum swinging and count how many swings it does in 30 seconds or a minute. Then start it by pulling further back and again count.  Ask what the important variables might be and what questions come up. Don't answer any but challenge the students to explore and develop investigation questions.	

### 3. Which Tea Cup?

<b>Where</b>	Classroom
<b>Equipment at the station</b>	Thermos of hot water or a coffee pot of hot water. 6 or 8 ounce Styrofoam* cups a ceramic cup which will hold 8 ounces of liquid a metal cup which will hold 8 ounces of liquid (all metal not an insulated travel cup) thermometer (not containing mercury)
<b>Warehouse equipment</b> (things the students can use in their investigation if they think of needing them)	Measuring cup or graduated cylinder an insulated travel cup stopwatch clock in room
<b>Demonstration</b> Fill the Styrofoam, ceramic, and metal cups about ½ full of hot water and record the temperature in each. (Using a smaller amount of water makes the cooling take place more quickly as you talk) Ask which cup do the students think would “keep the water hottest.” Ask what the important variables might be and what questions come up. Don’t answer any but challenge the students to explore and develop investigation questions.	

### 4. Alka-Seltzer\* and Water

<b>Where</b>	Classroom with sink and source of cold and hot water and a way to provide heated water such as a hot plate or coffee pot. (ice water if possible)
<b>Equipment at the station</b>	Hot and cold tap water, (ice water and near boiling water if possible) (hot pad or glove as needed) Alka-Seltzer* tablets broken in quarters 6 or 8 ounce plastic cups – clear if possible
<b>Warehouse equipment</b> (things the students can use in their investigation if they think of needing them)	Measuring cup or graduated cylinder a balance for weighing pieces of Alka-Seltzer* used stopwatch thermometer (not containing mercury) clock in room additional supply of Alka-Seltzer and Efferdent* tablets

**Demonstration**

Fill one of the cups about  $\frac{3}{4}$  full of cool tap water. Drop in one of the quarter pieces of Alka-Seltzer and watch it bubble. Repeat with hot tap water. The reaction rate is quite temperature sensitive. Offer to repeat with almost boiling water and ice water.

Ask what the important variables might be and what questions come up. Don't answer any but challenge the students to explore and develop investigation questions.

**5. Straw Airplanes**

<b>Where</b>	Outside or in a long deserted hallway or other large space
<b>Equipment at the station</b>	Straws Tape Paper (have a model constructed)
<b>Warehouse equipment</b> (things the students can use in their investigation if they think of needing them)	Measuring tape Masking tape Paperclips for weights

**Demonstration**

Have two models constructed one with small rings of paper (about 1" diameter) and one with large rings of paper (about 3" in diameter). Throw each and ask which flies better. Encourage operational definitions of "flies better" and ask what the important variables might be and what questions come up. Don't answer any but challenge the students to explore and develop investigation questions.

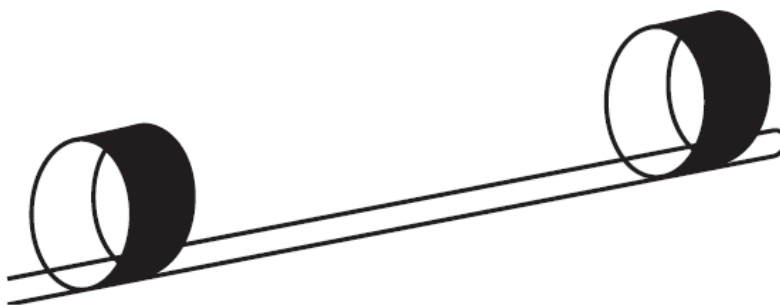

## 6. Lifesavers\*

<b>Where</b>	In the classroom
<b>Equipment at the station</b>	A package of Lifesavers for each student
<b>Warehouse equipment</b> (things the students can use in their investigation if they think of needing them)	Plastic cups Water Liquid volume measuring devices (kitchen measuring cups or graduated cylinder)
<b>Demonstration</b> Simply ask students to think about exploring the properties. ( <i>Have the large group discussion before you allow students to start eating the Lifesavers!</i> ) After a few ideas are brought out, have the students work in pairs to generate questions.	

*Typical inquiry questions for group investigations.*

*These all present an opportunity to talk about the advantage of doing multiple trials and averaging results.*

### Cars and Ramps

1. Which car rolls off the ramp the farthest? (*measure distance from bottom of ramp to where car stops.*)
2. Do cars roll just as far going forward as backwards? (*measure distance from bottom of ramp*)
3. Which car rolls off of the ramp the fastest? (*measure which car gets to a point 20 cm past the end of the ramp first*)
4. Does ramp angle effect distance a car rolls out? (*Measure angle and distance from bottom of ramp to where car stops.*)
5. Does length of ramp effect distance a car rolls out? (*Measure length of ramp and distance from bottom of ramp to where car stops.*)
6. Using a U-shaped ramp which car will climb highest on the opposite wall? (*Measure from bottom of U to the highest point the car climbs*)
7. Do cars with larger wheels roll out farther? (*Measure wheel diameter and distance from bottom of ramp to where car stops.*)
8. Do heavier cars roll out further? (*Measure car mass and distance from bottom of ramp to where car stops.*)



9. Do cars with less cross sectional area roll out further? (*Measure height of car and width-calculate area and distance from bottom of ramp to where car stops.*)
10. Does oiling the axle/wheel surface effect roll out? (*Run cars without oiling then add a drop of oil and then run again. Measure distance from bottom of ramp to where car stops.*)
11. Does the ramp surface effect the roll out distance? (*Run cars on smooth surface ramp and then on ramp with sandpaper taped to it. Measure distance from bottom of ramp to where car stops.*)
12. Does adding a "sail" reduce roll out distance? (*run the cars without a sail then tape a one square inch "sail" to the car to increase air resistance and run again. In each case, measure distance from bottom of ramp to where car stops.*)

### **Dr. Pepper\* and Mentos\***

1. Does the number of Mentos affect the amount of reaction? (*Measure the number of Mentos used and the volume of liquid remaining after each reaction.*)
2. Does the temperature of the liquid effect the amount of reaction? (*Measure the temperature of the liquid and the volume of liquid remaining after each reaction.*)
3. Does the type of soda pop effect the amount of reaction? (*Record which soda is used and measure the volume of liquid remaining after each reaction.*)
4. Do diet drinks react differently than non-diet drinks in the amount of reaction? (*Record which soda is used and measure the volume of liquid remaining after each reaction.*)
5. Do caffeine drinks react differently than non-caffeine drinks in the amount of reaction? (*Record which soda is used and measure the volume of liquid remaining after each reaction.*)
6. Do crushed Mentos have the same effect as an equal mass of whole Mentos\* in the amount of reaction? (*Use the same number of Mentos\* in each reaction. In half the cases, crush the Mentos before reacting. Measure the volume of liquid remaining after each reaction.*)
7. Does the flavor of Mentos used effect the amount of reaction? (*Record the flavor used and measure the volume of liquid remaining after each reaction.*)
8. Do other candies react the same as Mentos\*? (*Use the same mass of various candies. Record the type of candy and measure the volume of liquid remaining after each reaction.*)
9. Does adding Mentos in one at a time have the same reaction effect as putting two in at the same time? (*Run one reaction by putting one Mentos\* in the bottle and after that reaction stops, put in another. In the second reaction, put both Mentos\* in at the same time. In both cases, measure the volume of liquid remaining after the reaction stops.*)
10. Does adding two Mentos have twice the reaction as adding one? (*Measure the volume remaining after putting two Mentos into a bottle. Compare this to the volume remaining after putting one Mentos into a bottle.*)

11. Do various powders have the same effect as crushed Mentos\* on the amount of reaction? (*Compare the same mass of crushed Mentos, flower, sugar, Equal\*, salt. In each case, measure the volume of liquid remaining after the reaction stops.*)
12. Is the amount of reaction using two Mentos in a two liter bottle double that of using one Mentos in a one liter bottle? (*In each case, measure the volume of liquid remaining after the reaction stops.*)

### **Alka-Seltzer\* and Water**

1. Does the temperature of the water effect the reaction rate? (*Measure the water temperature and the time it takes for the tablet to dissolve*)
2. Does using a crushed tablet effect the reaction rate? (*Measure the time it takes for all the powder to dissolve*)
3. Does adding a little vinegar to the water effect reaction rate? (*In both cases, measure the time it takes for all the powder to dissolve*)
4. Does the reaction take twice as long at 10° C as it does at 20°C? (*Mix cold tap water (or ice water) and hot tap water to get the right temperatures. In both cases, measure the time it takes for all the powder to dissolve*)
5. Does the reaction take half as long at 40° C as it does at 20 ° C? (*Use warm tap water and hot (not boiling) water from a coffee pot. In both cases, measure the time it takes for all the powder to dissolve*)
6. How does the reaction time for two tablets in two cups of water compare to the reaction time for one tablet in one cup of water? (*In both cases, measure the time it takes for all the powder to dissolve*)
7. How does the reaction time for an Alka-Seltzer\* tablet compare to the reaction time of an Efferdent\* tablet? (*In both cases, measure the time it takes for all the powder to dissolve. Calculate grams reacting per second if necessary.*)
8. Which reaction is more sensitive to temperature change Alka-Seltzer\* in water or Efferdent\* in water? (*Do both reactions in hot and cold water, measure the time it takes for all the power to dissolve. Compare. Calculate grams reacting per second if necessary.*)

### **Straw Airplanes**

1. Does the diameter of the rings effect the flight distance? (*Run trials with small rings and with large rings. Measure the ring diameter and distance flown*)
2. Does the diameter of the rings effect the accuracy of flight? (*Run trials with small rings and with large rings. Measure the ring diameter and distance from target*)
3. Does using a large ring at front and a small ring at the rear improve flight distance? (*Run trials with large rings, small rings and large in front & small in rear. Measure the flight distance.*)
4. Does using a small ring at front and a large ring a the rear improve flight distance? (*Run trials with large rings, small rings and small in front & large in rear. Measure the flight distance.*)

5. Does using a large ring at front and a small ring at the rear improve flight accuracy? *(Run trials with large rings, small rings and large in front & small in rear. Measure the distance from target y.)*
6. Does using a small ring at front and a large ring at the rear improve flight accuracy? *(Run trials with large rings, small rings and small in front & large in rear. Measure the distance from target.)*
7. Does length of the straw effect the flight distance? *(Run trials with long and short straws. Measure distance flown.)*
8. Does length of the straw effect the flight accuracy? *(Run trials with long and short straws. Measure distance from target.)*

### **Lifesavers\***

1. Which color dissolves more quickly?
2. What is the distribution of flavors in a number of packages of Lifesavers\*? *(Count the number of each flavor in a large number of packages of Lifesavers\* The candies can then be used in other investigations)*
3. Do Lifesavers dissolve more quickly in water or vinegar? *(Measure time it takes for the whole Lifesaver\* to dissolve in each)*
4. Are the weights given on a package of Lifesavers accurate? *(Measure the weight contained in a large number of packages. The candies can then be used in other investigations.)*
5. Do Lifesavers dissolve more quickly in hot water than cold? *(Measure the temperature of the water, and the time it takes to dissolve the whole candy)*
6. Do Lifesavers dissolve twice as fast in water at 20°C as in water at 10°C? *(Use cold tap water and hot tap water mixtures to get the right temperatures, Measure the temperature of the water, and the time it takes to dissolve the whole candy)*
7. How do dissolving rates of Lifesavers in water at 5, 10, 15, 20, 30, and 40°C compare? *(Use mixtures of ice water, tap water, hot tap water, and water from a coffee pot (not boiling) to get the right temperatures. Measure the temperature of the water, and the time it takes to dissolve the whole candy. Make a graph of results.)*
8. Does constant stirring effect the rate of dissolving of Lifesavers? *(Run trials with and without stirring. Measure time it takes for the whole Lifesaver\* to dissolve)*
9. Which dissolves faster, a Lifesaver or an equal mass of sugar? *(Measure the time it takes for each to dissolve)*
10. Which dissolves faster a Lifesaver or an equal mass of salt? *(Measure the time it takes for each to dissolve)*

## Week 9

### Managing Data and Bar Graphs

**Overview** – Students participate in a group investigation about exercise and heart rate to learn to collect and manage data and create a bar graph.



[Johnnie's Math Page](#)

provides interactive tools for students to create bar graphs and manage data.

#### Teacher to Teacher Background

- Most middle school students have difficulty organizing the data they gather into meaningful displays that convey their results. A graph is the student's visual display of the relationship of variables in the experiment. When data is placed into a graph, patterns are more easily seen and conclusions more easily drawn.
- One of the most difficult steps of graphing is knowing where to place the independent variable and the dependent variable. Remind your students:

**Dependent Variable**  
(Y Axis)

**Independent Variable**  
(X Axis)

- If you need a refresher on what these terms mean, refer to the Glossary in Appendix A. It is a good idea to use these terms often so students begin to use them too.
- **Names of variables - a difficult situation:** In some situations the students don't actually modify the independent variable themselves. For example, if it's an *observational study* and students are counting the number of butterflies seen on days of different temperatures, they probably are taking data every day and then putting it in order by temperature. Here, temperature is the independent variable (which students don't manipulate), and the number of butterflies is the dependent variable. You may have to help students in these situations identify their variables.
- We strongly discourage you from allowing the students to use computers or graphing calculators to create data tables and graphs. Students need to understand the concepts behind organizing their own data before they rely on technology to do it for them.

- Explain that when any experiment is being done, the scientist must decide how to organize the data being collected. The first step is to decide on an organizational technique for the data table and then for the graph. The students will be doing both today.

## Teacher Tasks Before the Session

- Assemble:
  - 8 stopwatches, if available (1 per pair of students)  
*If stopwatches are not available, make sure you have one to read aloud from or a large clock with a second hand all students can see.*
  - Make or get from a math teacher one large piece of graph paper.
  - Cut out and make a photocopy of a graph and a table from the local newspaper. These can usually be found in the daily weather section. You also can get a graph from any science textbook.
  - Make photocopies of the data table below.

## Tasks During the Session

- Distribute the copied newspaper graph and table when students arrive. Ask,



*What do these tell us?*

- After students answer, ask them about their prior experience working with and making data tables and graphs. You will probably find their experiences varied.

- Pose the question,



*How does gender affect the heart rate of a teenager?*

- Allow some time for students to give their opinions. Encourage them to think scientifically and not emotionally.
- Ask for suggestions on how to scientifically answer the question. Make sure you guide them toward suggestions that *will generate data that can be used to answer the question.* (For example, students could first run, walk up stairs, do sit-ups, etc, and immediately afterward take their heart rates for 15 seconds.) *Students should only take their own pulse, not a partner's.* Taking the pulse of a partner often brings up middle school classroom management issues.

### Human Subjects

As students get ready to check their own pulse, it might be a good time to bring up the care scientists take in working with human subjects.

If this was a Fair project or a procedure conducted in a research institution, a committee would have to review and approve the proposed investigation. The committee would look at issues of safety, ethics and privacy and determine the risk level to the subjects. The researcher is not allowed to make this decision; an impartial committee must decide. This even applies in situations such as ours, where researchers are using themselves as subjects.

In a "minimal risk" situation, like ours today, the researcher would be allowed to proceed. If the risk were more than minimal, the subjects are given an explanation of the risk and their informed consent is obtained.

- Note: Now is a good time to discuss with students investigations that involve human subjects. See box above.
- Once an investigation is agreed upon by the group, discuss exactly what data students will collect, with what instrument and in what data table it will be recorded. Explain that a data table is a table in which scientists record the data they collect as they are collecting it. It is not meant to graphically display and highlight the results of an experiment. That is a graph's job. **A good data table includes a title, what a scientist is measuring and/or changing (known as variables), units of measurement and sufficient space in which to record the data.**
- Have each pair of students create a data table they think would work for the heart rate investigation. If they need help, provide a photocopy of the table below.
- Assign pairs the task of gathering their data and recording it in their data tables. Here is an example of a data table that would work.

Heart Rate (15 sec)						
	Trial 1	Trial 2	Trial 3	Trial 4	Trial 5	Average
Male						
Female						

- Students may need a reminder of how to determine their heart rate, but most will have experience doing so. (Do not use thumbs; place fingers along pulse points either on their own neck or wrist.)
- After the data has been collected, review the process and value of determining an average, and have each pair write their average for male and female on the whiteboard. Each group should then find a final average for all females and males tested in the investigation.
- It is now time to graph! This week, the focus is on bar graphs. Make the graph together on the large graph paper you have collected. Review the idea of dependent and independent variable.
- A good graph must:
  - have a title
  - have axes labeled, including units of measure
  - make adequate use of space (data should not be bunched up in a corner)
  - be accurate
- Remind students that when creating a graph, they must answer two questions for themselves. First is where to start on the y-axis (intercept); second is what value each square on the y-axis will represent (scale).
  - In determining the intercept, the students will either choose to start at  $y=0$  or have the base be the lowest value of their data.
  - In determining the scale, the students will want to consider the range of their data. They will have to select a scale that will fit in their largest

value for y. Here are three different bar graph examples for the same data:

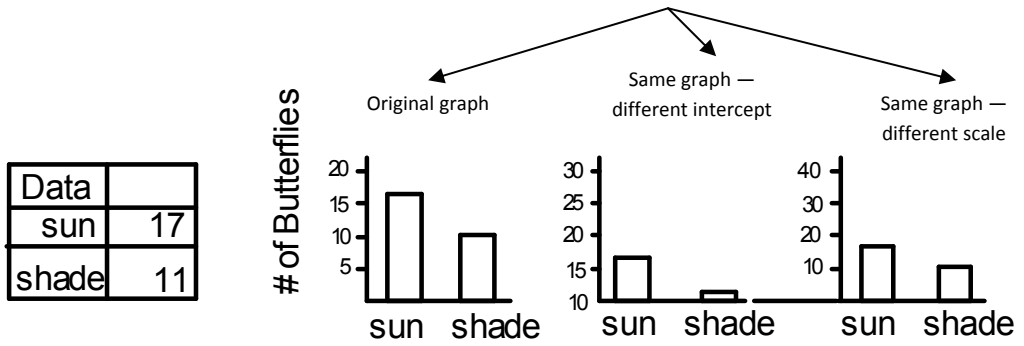

- Notice how the scale and intercept choices change the “look” of the amount of difference in the results.

### Teacher Tasks After the Session

- Keep the graph and data tables your students created today. You may want to refer to them next week as you practice organizing more data.

## Week 10

### Managing Data and Line Graphs

**Overview** – Students participate in a group investigation about temperature over time to learn to collect and manage data and create a line graph.



[Johnnie's Math Page](#) provides interactive tools for students to create line graphs and manage data.

#### Teacher to Teacher Background

- Last time we introduced the bar graph. This lesson focuses on the line graph. The line graph is used when data follows points on a continuum, such as temperature changes over a specified period of time.
- Students at the middle school level may need extra help determining the appropriate graph for the data they collect. If time allows, let them learn by doing and redoing; they will learn more that way than if you do it for them.
- The simple lab you will conduct this week can be varied to suit your individual group needs and available time and equipment. The goal, once again, is to practice good investigation techniques and also to generate data that can then be represented as points on a line graph.
- Since the goal is to practice line graphing, don't spend too much time on prior discussion or you won't get to the graphing portion.

#### Teacher Tasks Before the Session

- Assemble:
  - 16 cups of equal size (8 of which need lids). We suggest you use yogurt containers as long as the water is not boiling.
  - hot plates or microwave for heating water
  - 16 thermometers
  - water
  - beaker or graduated cylinder to measure equal amounts of water for each container
- Heat the water before students arrive to save time.
- Determine how much water will fit into each cup. If you can have the water poured into the cups before students arrive, you will save time.
- Have enough copies of data table, "Data Table: How Much Warmer Does a Lid..." ♦ and a piece of graph paper for each student pair.



## Tasks During the Session

- Organize students into pairs for this activity.
- Pose the following question on the whiteboard when students arrive:



*How does a lid on a cup affect the rate at which a hot liquid cools as compared to a cup without a lid?*

- Ask,



*What should we be measuring in order to answer the question?*

- Allow some discussion. They should move toward identifying that they should be measuring time and temperature.
- Review how to properly read a thermometer, and inform students of the timepiece they will use.
- Have students gather their equipment, including a copy of the data table, and begin to collect data. All students should read the temperature of their containers every 30 seconds for 10 minutes.
- After the 10 minutes is over, students should begin to determine how to label their graph axes. Remind them of the placement of each type of variable.
- It will probably be difficult for most students to determine the range for the vertical axis. You may have to help here. See Week 9 if you need help.
- Here is the effect of intercept and scale on line graphs. (Compare to the bar graphs from last week.)

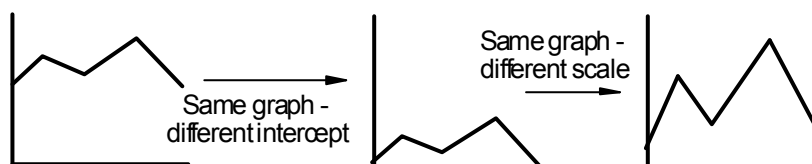

- Once students are satisfied with their graphs, examine them and provide suggestions for improvement if needed.
- Have students look at their graph. Does it really communicate the trends in their results? Would it help to add titles, labels or annotation to the graph as they would to a diagram?
- If time allows, refer to the previous bar graphing exercise, and ask the students if they could have placed today's data in a bar graph. It should be somewhat obvious to them that a bar graph would not be a good way to represent today's data. Help them think about how they would show all the

data they've taken. The best they could do with a bar graph would be to show the comparison of ending temperatures. Line graphs are good for showing data taken continuously and not just at the end of an event or for an average of data.

### Teacher Tasks After the Session

- You will need your Science Coaches in a few weeks to help students refine their individual investigation questions and later on, their investigation designs. If you are unable to use you will want to contact another science teacher (at your school or another middle or high school) to help you. Remember, retired science teachers are a great resource, too!

**How does a lid on a cup affect the rate at which a hot liquid cools as compared to a cup without a lid?**

**Data Table:**

Time (minutes)	Temperature with lid (°F)	Temperature without lid (°F)
0		
0.5		
1.0		
1.5		
2.0		
2.5		
3.0		
3.5		
4.0		
4.5		
5.0		
5.5		
6.0		
6.5		
7.0		
7.5		
8.0		
8.5		
9.0		
9.5		
10.0		

## Week 11

### Investigative Questions

**Overview** – Students will work to identify relationships between variables and develop good inquiry questions.



[Discovery Education: Science Fair Central](#) lists testable questions with corresponding variables that may help your students as they begin to develop their own inquiry questions.

#### Teacher to Teacher Background

- This strategy gets students to choose a topic of interest to them, identify actions of the topic and then to see relationships between changing the action and a measurable change. Students will want to go directly to the question forming stage. Do not let them. They will only be able to question once they have a topic, an action, and a way to measure the affect of changing the action. Tell them in advance that they will not write a question until all four steps are complete.
- Students may find that they cannot identify a change or they cannot scientifically measure the change in an action. Encourage the student to continue to work either using the same topic or choosing a new one. Hand out two copies of the strategy so students know they are not expected to “get it right” the first time.
- If your students are new to the inquiry process, you may want to begin with the group brainstorming realistic topics to investigate. Write the list on the whiteboard and keep it up while your students are completing the form. You may even want to complete one as a class so the students know what to do. An example is filled out below.

#### Teacher Tasks Before the Session

- Be sure you’ve contacted your Fair Director about organizing a group of “Science Coaches” to whom your students can send their questions and later, investigation designs, for comment. (See Teacher Tasks After Club Meeting in Week 10.)
- Make copies of the “Four Question Strategy for Inquiry Question Development” ♦ for students and copy the teacher version for you to use.
- Make a two-sided handout for each student and extras. Some of your students will need several tries before they find a relationship they can measure.

## Teacher Tasks During the Session

- Brainstorm the list of realistic topics. Write down the list as the students call out topics. Leave the list on the whiteboard as students begin to fill out their own forms.
- Complete an example together with the whole class.
- Be available to assist students while they are working, but try to leave the process to them as much as possible.

## Teacher Tasks After the Session

- Keep the Four Step worksheets your students completed in their working files.

## Four Question Strategy for Inquiry Question Development

Student name:

\_\_\_\_\_

Q1: A topic I can realistically investigate is:

\_\_\_\_\_.

Q2: A \_\_\_\_\_ usually acts in the following ways:

- a. \_\_\_\_\_
- b. \_\_\_\_\_
- c. \_\_\_\_\_
- d. \_\_\_\_\_
- e. \_\_\_\_\_

Q3: I can change the actions of the \_\_\_\_\_ by changing the:

- a. \_\_\_\_\_
- b. \_\_\_\_\_
- c. \_\_\_\_\_
- d. \_\_\_\_\_
- e. \_\_\_\_\_

Q4: I can measure the change of the actions by using a \_\_\_\_\_ and the units \_\_\_\_\_.

- a. \_\_\_\_\_
- b. \_\_\_\_\_
- c. \_\_\_\_\_
- d. \_\_\_\_\_
- e. \_\_\_\_\_

**A question that I can investigate about \_\_\_\_\_ is:**

### Four Question Strategy for Inquiry Question Development (*example*)

Student name: Nico Smith

Q1: A topic I can realistically investigate is basketballs.

Q2: A basketball usually acts in the following ways:

- a. bounces
- b. will roll with a force
- c. flies through the air when thrown
- d. goes flat over time
- e. holds air

Q3: I can change the actions of the basketball by changing the:

- a. surface I bounce it on/ air pressure inside the ball
- b. the force I roll it with/ air pressure inside the ball
- c. the force of the throw/ the type of air-hot or cold
- d. the temperature it is stored in/amount of pressure it starts with
- e. ????

Q4: I can measure the change of the actions by using a \_\_\_\_\_ and the units \_\_\_\_\_.

- a. meter stick/ centimeters. how high it bounces
- b. not sure how to measure the force??/air gauge
- c. not sure how to measure the force?/can use thermometer to measure air temperature...use a walk-in refrigerator and a heated room
- d. a thermometer to measure room temperature/temperature gauge
- e. \_\_\_\_\_

**A question that I can investigate about basketballs is:**

*Does the temperature a basketball is stored in affect the height of its bounce?*

## Stage 3: Students Prepare for Their Own Investigations

---

**Students spend time involved in structured preparations for their own inquiry projects.**

A few important notes before you begin this stage:

- Immediately following these notes is a “Flow Chart: From Topic Idea to Fair Day.” ♦ Yes, it does look a little intimidating at first glance, but as you delve into the process, these steps will make sense. The chart will alert you to paperwork requirements, as well as give you a clear picture of where you and your students are heading.
- The road to your Affiliated Fair involves *a lot* of paperwork that can be daunting your first time around. Try not to get discouraged with all the forms you and your students encounter. They are meant to document and ensure safe, fair and ethical investigations from all competitors. Current Intel ISEF forms can be found online:  
<http://www.societyforscience.org/isef/document>
- At the same time, take advantage of the opportunity to show a positive attitude to students about the rules and forms. Accountability systems such as this provide the safeguards that protect the public, the investigation subjects and the researchers. Documenting such safeguards is just part of the life of a scientist.
- We recommend steering middle school students clear of projects that will bring them into contact with some of the more complicated Intel® ISEF rules. Read carefully the Teacher to Teacher in Week 12 for more information on this subject.
- In this Stage, you will be sending some students’ investigation designs (a.k.a. research plans) to the Scientific Review Committee (SRC) for advice and approval. This committee consists of volunteer scientists who have been recruited by the Fair Director. They will advise students on the health, safety and ethical issues involved in their investigations and give approval to projects requiring it before students proceed with experimentation. Although the SRC applies some complex Intel® ISEF rules, it is dedicated to helping students (and teachers) navigate through these rules to success.



Before starting your students on their own projects, ask yourself one more time, “Are they ready to generate their own inquiry questions?”

If they have had lots of experience in this, move forward to Stage 3.

If they still need lots of support, do more of the group investigations found in week 8.



- If you are using these activities more than once a week, you should read the "TEACHER TASKS BEFORE THE SESSION" and "TEACHER TASKS AFTER THE SESSION" a few weeks ahead so you don't get caught short in organizing needed materials and arrangements.

#### Miscellaneous Tips From A Teacher Who's Been There:

- Buy some "Sign here" Post-it\* Notes for all the forms and paperwork students will be bringing home. That way, you can easily mark where students and parents need to sign.
- If students are studying plant germination and are pushed for time, they can use radish seeds, which are fast-germinating. Presoaking any seed will help it germinate faster. Lima beans are a good choice if students want to measure plant growth, as these beans grow linearly on a single stem.
- If you plan to conduct a school fair, start early to make arrangements. A few months lead time is not unusual for a well planned event.

#### Specific notes for specific situations:

##### Using this *Guide* for Classroom instruction

- Watch for notes which start "Class:" they will help you with special adaptations for classroom use of this *Guide*.
- One issue for classroom teachers will be the number of projects you will be dealing with. Student help needs, supervision, storage, materials and space limitations are more likely to be issues than with clubs with ten students. Plan ahead.

##### Using this *Guide* for an after school club

- Watch for notes which start "Club:" They will alert you to special adaptation for use of this *Guide* in after school club situations.
- Club students often have sporadic attendance. Have ways to contact students outside of meetings so that you can encourage regular attendance and shepherd those parts of your flock that get lost.

## Flowchart: From Topic Idea to Fair Day (and other events)

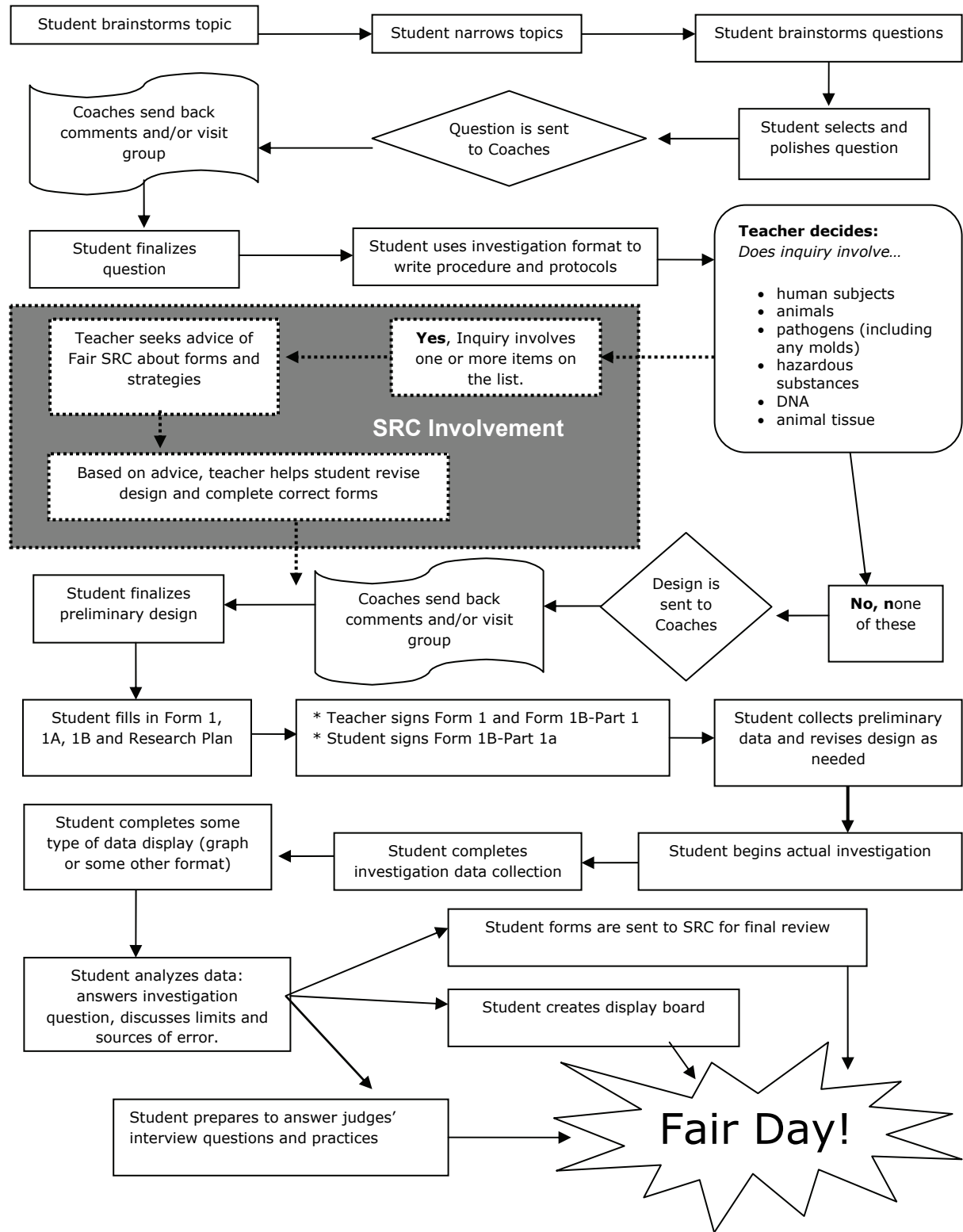

## Week 12

### Brainstorming Topics and Generating Questions

**Overview** - Students will brainstorm topics for their individual investigations and will generate science inquiry questions around those topics.

#### Teacher to Teacher Background

- **Importance of a Good Question:** One of the most important tasks in science inquiry is to develop a good, testable question. Students who design a good question have little trouble the rest of the way.

*"No project gets better than the question."*

- Teacher with years of experience in teaching inquiry

Questions with significant problems lead the students into disastrous results and leave them feeling frustrated and incapable of being successful in science. For this reason, you will spend two lessons, this week and next, getting students to formulate solid questions they can use for their own investigations.

- **Keeping Interest Strong:** If students choose a question that is interesting to them, they will be more successful. You will spend a considerable amount of time in this lesson working on getting students to think of a question that will still interest them several weeks from now.

#### Parents and Science Fair Topics

Once in a while, parents helping students select a topic for a science fair project misdirect them. Unless parents have a good understanding of *inquiry* science fairs, they might suggest demonstrations, models or "canned experiments" found in trade books on science fairs. Or, they may suggest a topic they did in a science fair as a child.

Help these well-meaning parents remember that in *inquiry* science fairs, each student poses a research question and designs a way to gather data to answer it. Their children are actually being student scientists when they do inquiry projects.

- **Resources:** Some websites have been provided in Appendix C of this *Guide* to help your students if they get stuck. We encourage you to allow them to use these sites only to search for topic ideas and not to find their exact inquiry questions (though they may tweak ones they find to fit their own interest). Beware: Many resources may refer students to demonstration- or presentation-type projects. While the content knowledge conveyed by these kinds of projects is important in science, these kinds of displays do *not* fit with the inquiry skills we are developing in the program.

- **Team projects:** At this time, some students may know they want to work together. Once again, we strongly discourage teams larger than two.



Are your students getting stuck with generating ideas for science inquiry questions? [Science Buddies](#) offers a directory of science fair topics to help them get started.

- **Complex Topic Areas - Complex Rules:** We recommend that you become familiar with the Intel ISEF Affiliated Fair Rules and Guidelines, which can be found online: <http://www.societyforscience.org/isef/document>
- Many first-year teacher-participants are wise to guide students away from projects that will involve them with the most complex areas of Intel® ISEF rules. Those rules are reasonable and designed to deal with the health, safety and ethical issues of doing scientific research. They are intended to protect the student investigators, their teachers and the public. Because the issues and hazards are complex, the rules are often complex.

The areas listed below lead to encounters with Intel® ISEF rules that most middle school students (and their teachers!) will find very complex. (We have summarized these recommendations into a table on page 79 to assist you.)

NOTE: The *italicized* words in the section below are found in the Glossary in Appendix A.

- **Human subjects** – Any investigation that has students interviewing, surveying or using humans as subjects in any way will need to have prior approval from the *Fair Scientific Review Committee (SRC)*. The more risk involved to the subject, the more documentation will be required. Many first-year teacher-participants will guide students away from *human subject* investigations or at least only allow those with *minimal risk*.
- **Vertebrate animals**– Students doing investigations with mammals or other *vertebrate animals* will need prior SRC approval. Many first-year teacher-participants will guide students away from vertebrate animal investigations. Many middle school fairs restrict them to *passive observational studies* of home pets, farm animals, wild animals or zoo animals. Be sure to check local affiliate rules.
- **Human and animal tissue** – Investigations involving *human and animal tissues* will require prior approval by the SRC and the direct supervision of a *Designated Supervisor*. Many first-year teacher-participants will guide students away from tissue investigations or at least restrict them to tissues obtained from food sources (grocery stores, restaurants or meat-packing plants). Be sure to check local affiliate rules.
- **Controlled substances** – Studies involving controlled substances require prior SRC approval and adherence to all applicable laws. Most middle school students will not be involved in such investigations.
- **Recombinant DNA (rDNA), Radiation and Radioactive substances**– Most middle school fairs will not accept projects involving rDNA, radiation or radioactive substances. Be sure to check local affiliate rules.
- **Hazardous substances and devices** – A wide variety of inquiries could involve devices or substances which may be hazardous to the student, the subjects of the investigation or to the public. Teachers must ensure that adequate instruction, controls and supervision are provided to the student if such devices

or substances are used. The use of hazardous chemicals should be guided by the instructions on the appropriate MSDS.

- **Pathogenic or potentially pathogenic agents** – Most middle school fairs will not accept projects involving pathogenic or potentially pathogenic agents. Be sure to check local affiliate rules. The Intel® ISEF rules specifically allow three bacterial cultures and state they need not be considered pathogens. Visit the website for more information: <http://www.societyforscience.org/isef/document>

## Teacher Tasks Before the Session

- Record Keeping: Now is the time to label a folder for each student. From today's meeting onward, you will have students file ALL their work in this folder. They later will organize this work to be put into a project binder that they'll take to the Affiliated Fair. Fair judges may look at the binders to see the students' preliminary work, data records and any modifications students made to their investigations along the way. Keep these initial folders in your room. Stress to the students that *it is their job to file their work*.
- Make student copies of the form "Brainstorming Topics and Generating Inquiry Questions." ♦

## Tasks During the Session

- Use the brainstorming form as a guide to help your students generate questions from topics they enjoy studying. It usually helps if you can model the process along with them.
- After each section on the form, have the students pair-share or do other types of sharing that are successful in your classroom. This sharing will allow even more topics to surface as students hear ideas from another that they had yet to think of.

## Teacher Tasks After the Session

- Contact the Science Coaches who signed up to help to plan a date for the Coaches to review student questions.

## A Guide for Teachers on Investigation Topics

Topic Area	Our recommendation:
<b>Human Subjects</b>	Teacher's first year, limit to: <ul style="list-style-type: none"><li>- Simple surveys of adults</li><li>- Passive observation of legal, public behavior</li><li>- Minimal risk physical activity</li></ul>
<b>Vertebrate Animals</b>	Teacher's first year, limit to passive observation of pets, wildlife and zoo animals.
<b>Human and Vertebrate Animal Tissues</b>	For the teacher's first year, avoid projects in this area.
<b>Pathogens and Potential Pathogens</b>	For the teacher's first year, reject projects in this area. Middle school students will always need special mentoring.
<b>Controlled Substances</b>	For the teacher's first year, avoid projects in this area.
<b>Recombinant DNA</b>	For the teacher's first year, reject projects in this area. Middle school students will always need special mentoring.
<b>Radiation and Radioactive Substances</b>	For the teacher's first year, reject projects in this area. Middle school students will always need special mentoring.
<b>Hazardous Substances or Devices</b>	Carefully screen projects in this area. Middle school students may need special mentoring.

Student Name \_\_\_\_\_

## Brainstorming Topics and Generating Inquiry Questions

List four activities you enjoy doing outside of school:

- 1.
- 2.
- 3.
- 4.

Name at least two science investigations you have done that interested you:

- 1.
- 2.
- 3.

Circle all of the subjects below that interest you: (You may write in others.)

- |                    |             |             |                     |
|--------------------|-------------|-------------|---------------------|
| Plants/Flowers     | Chemicals   | Electricity | Animal Observations |
| Cars/Ramps         | Pendulums   | Music       |                     |
| Household Products | Comparisons | Weather     |                     |

You can use any of the topics above to create an inquiry question for your Fair project. Use the chart below to narrow your topic to a question.

Topic From Above	I Wonder About...	Materials Available	What I Might Measure

From today's activities, some questions I may want to investigate include:

1. \_\_\_\_\_
2. \_\_\_\_\_
3. \_\_\_\_\_

## Four Question Strategy for Inquiry Question Development

Student name: \_\_\_\_\_

Q1: A topic I can realistically investigate is:

\_\_\_\_\_.

Q2: A \_\_\_\_\_ usually acts in the following ways:

a. \_\_\_\_\_

b. \_\_\_\_\_

c. \_\_\_\_\_

d. \_\_\_\_\_

e. \_\_\_\_\_

Q3: I can change the actions of the \_\_\_\_\_ by changing the:

a. \_\_\_\_\_

b. \_\_\_\_\_

c. \_\_\_\_\_

d. \_\_\_\_\_

e. \_\_\_\_\_

Q4: I can measure the change of the actions by using a \_\_\_\_\_ and the units \_\_\_\_\_.

a. \_\_\_\_\_

b. \_\_\_\_\_

c. \_\_\_\_\_

d. \_\_\_\_\_

e. \_\_\_\_\_

**A question that I can investigate about \_\_\_\_\_ is:**



## Week 13

### Polishing Questions

**Overview** - Students learn more about what makes a good inquiry question before they refine their own question. This is the week student questions are sent to Science Coaches for comment.

#### Teacher to Teacher Background

- **Cautions about the Dr. Pepper\* and Mentos\* demonstration:** Try to develop the drama about what is going to happen. The whole demonstration is quite safe and dramatic, but very, very messy. Be prepared for the all of the Dr. Pepper\* to wind up on the ground outside the bottle. This demonstration should only be done outside. Have students standing *at least* four feet from the bottle and ready to back up. Make sure the runoff will go someplace where it won't cause trouble. Once you start the chemical reaction, get yourself out of the way.
- **Quality of student questions:** The quality of a student's research question will determine the difficulties he/she and you encounter for the remainder of this investigation process. It is, therefore, very important that students work on developing questions that meet the criteria of a good inquiry question as covered in this week's lesson.
- This is the same demonstration you used to recruit students, only this week the focus will be a little different. Since this is the second time students will have seen this demonstration, and they now know what to expect, direct their attention to what they are currently working on - developing good inquiry questions. Tell students that while they're watching this demonstration once more, be thinking about what questions they would like to test. What would they change or do differently to test variables?
- If there is time, you may want students to experiment in groups with this. If that is the case, have on hand different varieties of soda pop (in single-serving plastic bottles), a variety of different flavored Mentos™ candies and different hard candies (both fruit and mint flavored) that can be dropped into the bottle neck.

#### Teacher Tasks Before the Session

- Assemble for each repetition of the demonstration:
  - 1 two-liter bottle of Dr. Pepper\*
  - Four cinnamon Mentos\* candies
  - (See last bullet above if you plan to let students conduct their own trials.)

- Practice the demonstration once or twice with a group of friends or with family. (See cautions in [Teacher to Teacher Background Notes](#).)
- Be ready to repeat the demonstration for the students once they've discussed questions and variables.
- You'll want to prepare handout copies for students:
  - "Sample Student Questions – the good, bad and the ugly..." ♦
  - "Variables and Measurement" ♦
  - "Research Question Form." ♦
- Have ready to give back to students their forms "Brainstorming Topics and Generating Inquiry Questions" from last week's work.
- Make student copies of the "Research Question Form." ♦
- Make copies of "For Science Coaches: Sample Research Question Form" ♦ to send with your students' questions. This sheet will provide Coaches with some direction in their feedback.
- Be sure your Science Coaches know the date by which they need to return their feedback forms and that you know how you are going to get them back. If the Coaches are gathering somewhere to look over student questions as a group, it would be beneficial if you could join them at that time.

## Teacher Tasks During the Session

### Demonstration

- Start the meeting by taking students outside and doing the Dr. Pepper\* and Mentos\* demonstration. (Read the "Cautions" in [Teacher to Teacher Background Notes](#) above before doing this demonstration.)
- Procedure for the demonstration:
  - Have available a two liter bottle of Dr. Pepper\* and a package of Mentos\* candies. As you carry the Dr. Pepper\* outside, avoid shaking the bottle in any way.
  - Set the bottle on the ground and gently take off cap, still avoiding agitating the contents.
  - Hold four Mentos\* candies in your hand so that they are lined up and can be quickly dropped down the neck of the bottle.
  - Without lifting the bottle off of the ground, slide the candies into the open top of the bottle.

- Stand back!
- While still outside, and after the commotion settles among students, have them concentrate on the questions they'd like to experiment to answer. You'll hear questions from students such as:
  - Why does it do that? (Suggest that they need to break down "Why..." questions into questions that can be answered by gathering data.)
  - Does it work with Coke\*?
  - Does it work with 7-up\*?
  - What if you use Life Savers\*?
  - Would it work with Dr. Pepper\* that is very cold or warm?
- Once they are asking such questions you know they are thinking about variables even if they don't have that vocabulary yet.
- If you have time in your and are not intimidated by a big sticky mess outside (no matter the weather!), you may want to have students do some experimenting on their own. If you do not have the time to let students experiment individually or in groups, you can take questions from some and test them in demonstration fashion. Either way, make sure to chart the students' questions to revisit in the classroom.

### **Understanding investigation questions**

- Hand out "Sample Student Questions: the good, bad and the ugly..." ♦  
*We were talking about questions outside. I want you to tell me what you think of these questions as ones that students might investigate for a Science Fair. What would you say to students who wanted to use the following questions for their investigations? Can they collect data on these questions?*

### **(For the teacher: Sample Student Questions: the good, bad and the ugly)**

*Could you answer these questions by gathering data yourself?*

Question: When did T-Rex live on earth?

Comment to teacher: Use this question to point out that library research is not the same as gathering data for your own investigation.

Question: Do plants grow better if a little vitamin C is added to their water?

Comment to teacher: The question can be investigated if the student specifies which type of plant and operational definitions are made for the terms "grow better" and "a little".

Question: How does a volcano work?

Comment to teacher: Again, use this question to point out that library research/building a model is not the same as gathering data for your investigation.

Question: Which frozen liquid melts the fastest: water, milk or Pepsi\*?

Comment to teacher: Good question. The student will need to make an *operational definition* for "melts the fastest." The question can be investigated.

Question: Does your pulse rate increase or decrease after listening to different types of music?

Comment to teacher: Good question. The student will need to define how long after and which types of music. But, the question can be investigated.

Question: How much does a cricket's blood pressure go up when it chirps?

Comment to teacher: Impractical for students in this program. Good question for a scientist with special equipment but not for us.

Question: How fast is the current of the Congo River (in Africa)?

Comment to teacher: Use this example to point out that some questions are library research questions or that it is impractical for students in this program.

Question: How tall is the tallest mountain?

Comment to teacher: Again, this example is a library research question or it is impractical for students in this program.

Question: Which tree on our school campus will be first to lose all of its leaves in the autumn?

Comment to teacher: Almost a good question. But impractical since the autumn has passed for this year and won't happen again before the fair.

Next, hand out "Variables and Measurement." ♦

*I want to tell you another trait of good investigation question. In good questions, you will be able to easily identify what the investigator will be changing on purpose and what the investigator will be measuring. Let's look at a few.*

**(For the teacher: Variables and Measurement)**

Question: Does your pulse rate increase or decrease after listening to different types of music?

What is being changed? The types of music

What is being measured? Pulse rate

Question: How much of the liquid will come out of the bottle if we use Coke\* instead of Dr. Pepper\* in today's demonstration?

What is being changed? The type of liquid

What is being measured? The volume that flows out (by measuring the volume remaining in bottle and subtracting that from the label volume).

Question: How much of the liquid will come out if we use cold Dr. Pepper\* rather than room temperature Dr. Pepper\* in our demonstration?

What is being changed? The temperature of the Dr. Pepper\*

What is being measured? The amount that flows out (by measuring the volume remaining in bottle and subtracting that from the label volume).

Question: Which soil type absorbs the most water?

What is being changed? Soil type

What is being measured? Water absorbed

Question: Which type of leaf contains the most red coloring?

What is being changed? Type of leaf

What is being measured? Amount of red coloring (using paper chromatography)

Question: Do Alka-Seltzer tablets dissolve faster in hot or cold water?

What is being changed? Water temperature

What is being measured? Rate of dissolving (by measuring the time it takes to dissolve and dividing that into the label weight.)

*Let's talk about this one:* [show the whole thing]

Question: Are humid days more uncomfortable?

*If we are told that this student plans to ask people to rate their discomfort every day for three weeks, let's look at how the variables are handled.*

What is being changed? Humidity

*If there is a range in humidity over the period, he will compare days of different humidity with the same temperature (or about the same temperature).*

What is being measured? People's rating of discomfort

*It will be a good investigation if the student can design a scale for people to use to rate their discomfort.*

**CRITERIA** - Good questions for investigations are those that:

- *have components that can be changed (or be observed to change) and measure,*
  - *involve data gathering by the investigator*
  - *are practical, safe and ethical*
- Come back to the students' Mentos\* questions from the start of the meeting and examine them for the criteria just explained.

### **Students polish their own questions and pick one to send to Science Coaches**

 *Now let's look at your own questions you generated last week. You're going to work on developing a good investigation question around which you can do a science project for the big Fair.*

- Pass out the student questions they generated about their topic last week along with a "Research Question Form"♦ for each student.

 *First, work on your question and make sure it fits the criteria for a good investigation question - that it requires you to gather data to answer it, and that you know what you changing and what you are measuring. Then make sure it is a question that it is practical, safe and ethical for you to do.*

- Have students pick one question they want to develop and send to the Coaches. If a few students need to, they may send multiple questions and select later based on the Coaches' feedback.

 *If it's practical, put your question on the form I just gave you, the "Research Question Form." We'll send these to our Science Coaches, and they will make comments that will help us focus our questions and get us started with background research.*

*If you have anything else to explain about your topic or question, write it on the back of the form. The more you can tell the Coaches about your idea, the more help they can be to you.*

## Tasks After the Session

- Send student questions to Science Coaches for review. Be sure to let Coaches know the date you need to give their comments back to students so they can have their feedback finished by then. Include copies of "For Science Coaches: Sample Research Question Form"◆ with the package you deliver to them. Attend their review meeting, if possible.

## Sample Student Questions: the good, bad and the ugly...

1. When did T-Rex live on earth?
2. Do plants grow better if a little vitamin C is added to their water?
3. How does a volcano work?
4. Which frozen liquid melts the fastest water, milk or Pepsi\*?
5. Does your pulse rate increase or decrease after listening to different types of music?
6. How much does a cricket's blood pressure go up when it chirps?
7. How fast is the current of the Congo River (in Africa)?
8. How tall is the tallest mountain?
9. Which tree on our school campus will be first to lose all of its leaves in the autumn?



## Variables and Measurement

Question: Does your pulse rate increase or decrease after listening to different types of music?

What is being changed?

What is being measured?

Question: How much of the liquid comes out if we use Coke\* instead of Dr. Pepper\* in our demonstration?

What is being changed?

What is being measured?

Question: How much of the liquid comes out if we use cold Dr. Pepper\* rather than room temperature Dr. Pepper\* in our demonstration?

What is being changed?

What is being measured?

Question: Which soil type absorbs the most water?

What is being changed?

What is being measured?

Question: Which type of leaf contains the most red coloring?

What is being changed?

What is being measured?

Question: Do Alka-Seltzer tablets dissolve faster in hot or cold water?

What is being changed?

What is being measured?

*Look at this one -*

Question: Are humid days more uncomfortable?

What is being changed? Humidity

What is being measured? People's rating of discomfort

Student Name \_\_\_\_\_ Teacher \_\_\_\_\_

## Research Question Form

*Fill in sections 1-3 below and return to your science teacher.*

1) What is your question?

---

---

2) What are you changing? (Independent variable)

---

---

---

3) What are you measuring? (Dependent variable)

---

---

---

***Leave the space below this line for science coaches to fill in***

-----

Science Coach Comments:

---

---

---

---

Coach, can you suggest some key words to help with library or Internet research for science background on this question?

## Research Question Form (Sample, for Science Coaches)

You will receive these forms filled in by the students. Your task today is to look over the basic student question (and identified variables) to see if it constitutes something that can be answered by the student taking data.

Student Name Mario M. School M. view

**Research Question Form**  
Fill in sections 1-5 below and return to Science Club teacher.

1) What is your question?  
What is the best temperature for radish seeds to sprout

2) What are you changing? (Independent variable)  
The seeds will be kept at different temperatures. I will keep some in the fridge, some in the kitchen (warm) and some under a lamp (hot)

3) What are you measuring? (Dependant variable)  
I will count how many seeds sprout

4) Can you easily access materials needed to investigate your question? Yes  No

5) Does your question suggest an investigation that is safe and ethical? Yes  No

leave the space below this line for science coaches to fill in

---

Science Coach comments:  
• How will you measure BEST? do it the number of seeds that germinate?  
• Do seeds need light as your seeds in the refrigerator will not have much light.

Coach, can you suggest some key words to help with library research for science background on this question?  
- GERMINATION - SEED COAT

**Look at the question**

- Safe and ethical? Is the question inherently unsafe or unethical to research?
- Clear? Does the student need to develop operational definitions for any terms?

**Look at the variables**

- Feasibility? Will you be able to guide the student into a fairly simple way to monitor the variables?
- Quantifiable? Can the changes be quantified? Should you suggest the use of a self-designed scale for some types of variables such as "plant health?"
- Adequate Controls? Do you need to make suggestions about things to control and how to control them?

Make some suggestions of terms and phrases that might help in background research. [The student will be using middle school materials and the internet.]

In some cases, it will be difficult to write out your suggestions in a brief format. In this case, it would be extremely helpful to the student if one of the coaches could personally attend the next meeting to work with the student.

## Week 14

### Background Research

**Overview** - Students begin their library research on the scientific principles related to their questions. This background information will provide them with a solid base from which to launch their investigations.



[Science News for Kids](#) is an online science newsletter with additional books, articles, and web resources. Check here for current information and science facts presented in kid-friendly language.

#### Teacher to Teacher Background

- Keep reminding your students that it's their job to file all of their work in their project folders. This work will later be organized into a project binder that they will take to the Fair. Fair judges may look at the binders to see the students' preliminary work, data records and any modifications they made to their investigations along the way.
- Since students have had their questions reviewed, they may need help to modify them further based on comments from the Science Coaches. Some may even need you to help them develop a new question.
- Today's task is for students to discover information that is scientifically relevant to the questions they want to answer. The Science Coaches may have written some key words to help students get started in their research. If they do not, you will have to help the students do this.
- Note: Students sometimes have trouble transitioning from the exciting, hands-on investigations to the calmer, quieter tasks involved in library and Internet research. Stress to them that this research is an important part of a real scientist's work. Scientists need to understand the body of work that has preceded their own before they can add to and build upon it. Sir Isaac Newton said, in referring to the work of scientists gone before him, "If I am seeing further, it is because I am standing on the shoulders of giants." Students need a firm grasp of the content and concepts involved in their investigations. Just because book and Internet researching is perhaps not as stimulating as watching a whiz-bang demonstration, it is still very important to developing the habits of a good scientist.
- Background information usually can be found in scientific textbooks, science-related books, encyclopedias and on the Internet. Since many students do not have the skills that make them efficient researchers on the computer, we recommend steering them toward the books first. Of course, you know your students' capabilities and your school's resources best, and the computer may be your best option.
- Middle school students are expected to use age-appropriate resources and reference material at the middle-school level. They do not have to tackle

professional or college-level readings. Because research is being done, students need to cite all their sources of information in a bibliography. Your school probably has a style that is required; use it.

- The Intel® ISEF rules require each student to have at least five sources of background material cited in their research plan. Some local fairs have lesser requirements for Middle School projects.
- Sometimes students get taken up by the “spirit of the hunt” and spend all their time searching and copying and doing little reading. One way to encourage them to read is to ask them to highlight or make notes in copies of the material and put these in their files. Make sure they have adequate time to read and digest the material they find. Some of the material will be difficult for your students to understand. If you can, have volunteers available to help students.

(Note: Struggling readers and ELL students will most likely need a helper. There is not enough of you to assist all of your students at the same time so make sure you enlist some help.)

### Teacher Tasks Before the Session

- Have ready students’ “Question Forms” with comments from the Science Coaches. Coaches were asked to suggest key research terms at the bottom of that page.
- If applicable at your school, sign out computers for this week’s meeting. It will be best if there is an available computer for each student. You may also want to gather some textbooks or other resources you know will help the students gain insight into their topics. Be sensitive to the reading levels of your students and locate appropriate texts.
- Find out from your school librarian or language arts teacher the format your school uses for writing a bibliography. Most schools have a set format for all students to follow. Make copies of examples of that format for each student. You will also need to do some examples of citing sources with your students.

### Teacher Tasks During the Session

- Inform the students of the need to do research on the scientific principles they are using and to determine what is already known about their topic. Have them start with the keywords that their Science Coaches supplied on their question form.
- Carefully review the bibliographic format your students will use and give examples. Show students in the books where the required information can be found.

- The rest of the time in this session is spent with students researching their topics and recording information and resources. (You may need to remind students not to randomly print, but to cut and paste.)
- Again, remind your students to file all of their work in their folders that stay in the classroom. Later in the year, they will organize a project binder to take to the Intel® ISEF Affiliated Fair.

### Teacher Tasks After the Session

- Collect resources that students needed but were not available. You will want all students to have usable resources by the next session. You may have to do the finding for them and then let them do the reading.
- Rest!
- If you will need the computers again, sign up now.

## Week 15

### Background Research (Continued)

**Overview** - Students continue their library research on the scientific principles related to their questions.



#### Teacher to Teacher Background

- Students must continue to document their work by keeping it in their file.
- Since your students began this process in the last session, they should be well on their way. Your students will interpret the concepts differently and this process will be difficult for some. Require all students to have some background research.

#### Teacher Tasks Before the Session

- Collect the sources you did not have available last time. Students no longer have time to search; they need to be actively reading and writing the research for their project.
- Prepare student handouts of "Background Research Sentence Starters." ♦

#### Teacher Tasks During the Session

- Reemphasize the importance of background knowledge and research.
- Review the bibliography requirements for your students. Answer questions students may have found from last session.
- Discuss the sentence starters and hand out to students for reference.
- Float and make sure students are not searching for information, but they are processing the information they have found.
- Make sure students print out their background information and bibliography so you can give some feedback for the next session.

#### Teacher Tasks After the Session

- If you will need the computers again next week, sign them out.
- Review the work from today. You will want to give some feedback to students on their progress.

## Background Research Sentence Starters

The major scientific concepts related to my investigation are ...

Some of the research I found involving \_\_\_\_\_ shows that ...

The investigation is being done because \_\_\_\_\_ found that ...

Based on my research, I decided that I should ...

One technique I found to include in my investigation is ...



## Week 16

### Hypothesis

**Overview** - Students continue their research, refine their questions and write their hypotheses.

#### Teacher to Teacher Background

- Students should all have a working question by this time, so it is time to focus on the hypothesis. It is imperative that students understand *a hypothesis is only an educated prediction, not a right or wrong answer*. They should have some idea of what they think will happen and why they think that, but should not consider their project “wrong” if it doesn’t happen as they expected.
- Many times students make predictions on the outcomes of their experiments without stating a reason why. We have found it useful to require the word “because” in all hypotheses; this forces a reason why to be included.
- At this time in the process of developing a testable question, a well thought-out hypothesis and some scientific background information, you will find your students working at different rates and on several different items. Any volunteers who can assist with these tasks would be helpful to have at the meetings around now. Next week’s meeting will focus on writing their experimental procedure, so make sure all students have a final question by the end of this week’s meeting.

#### Teacher Tasks Before the Session

- Make sure you still have resources available for more work on background information.

#### Teacher Tasks During the Session

- Have students refer to their question sheet they sent to the coaches. Today, they need to write a hypothesis or a prediction of what they think will happen and why they think that. It is not their procedure or how they plan to test their hypothesis. It is a simple statement of what will happen as a result of their procedure. A useful format might be:

*I think \_\_\_\_\_ will happen because \_\_\_\_\_.*

- Students should write their hypotheses on the back of their “Research Question Forms” from Week 13. Ask them to share their questions and hypotheses with a partner. When students have to verbally explain it, they may see a need to clarify some more.

- The rest of the meeting is spent completing their background information searches and writing their bibliography if they have time. Once the background information is collected, they need to write it into a paragraph that relates it to their question.

### Teacher Tasks After the Session

- Make sure all students work up to this point is filed in their folders.

## Week 17

### Investigation Design

**Overview** - In the next two sessions, students write their investigation designs to send to the Science Coaches for comments.



Struggling students may benefit from viewing other [science fair project investigation designs](#) at Discovery Education: Science Fair Central.

#### Teacher to Teacher Background

- Writing descriptive procedures for an investigation design is not an easy task for most middle school students. We've tried to structure the task into bite-sized bits during the next two weeks. Even so, this can be a hard slog for many of your students, and they will need much encouragement and support from you.
- Today students will begin work on their preliminary investigation design. Students probably will modify their designs after they have been approved and as they begin to collect preliminary data. Science Coaches looking at these preliminary designs aren't looking for perfection. Coaches will be advised that once a project seems safe and ethical and allowable under Intel® ISEF rules, the Coaches should leave the fine tuning of the procedure and protocols for the student to do during the preliminary data collection phase.
- To keep students open to such modification, it helps to have them phrase their preliminary designs in the future tense. Later, as they edit and update their designs into a final form, they change to past tense.
- **Names of variables:** In some situations the students don't actually modify the independent variable themselves. (For example, if it's an observational study and students are counting the number of butterflies seen on days of different temperatures, they probably are taking data every day and then putting it in order by temperature. Here, temperature is the independent variable and number of butterflies is the dependent variable.) You may have to help students in these situations identify their variables.
- In writing the procedure and protocols, the standard test of how much detail to supply is to envision someone with about the same general experience as the investigator. The directions should allow such a person to repeat the investigation. Peer reading is an excellent way to have students see if they are being clear enough.

## Teacher Tasks Before the Session

- Copy "Investigation Design" pages:
  - Investigation Design Page 1: "Operational Definitions" ♦
  - Investigation Design Page 2: "Categories of Variables" ♦
  - Investigation Design Page 3: "Variables in my investigation" ♦
- Make student copies of handouts, "Which procedure style do you find easiest..."♦ and "Annotated Diagrams."♦
- Post the butcher paper sheet with the students' procedures from the Cars and Ramps activity.
- Make a craft stick model to hold up when you talk about procedure styles. (See handout, "Which procedure style...to follow" for directions. Use the kind of craft sticks that have notches precut.)

## Teacher Tasks During the Session

 *Today you are going to start to work out exactly how you will answer the question you've selected. When you have written your investigation design, we'll send it to our Science Coaches, who will read it and offer feedback. But the real audience for your design is the judges at the big fair we'll be going to in the spring.*

### **OPERATIONAL DEFINITIONS**

 *One of the first things you'll need to do is to clarify or define any vague terms you've used in your question. This is called stating an "operational definition" for these terms.*

*For example, if someone wanted to investigate the question, "At which angle do the cars roll off the ramp best?" they'd have to explain what they mean by "roll off the ramp best." Here are some of the things that might mean:*

- Hand out "Investigation Design Page: "Operational Definitions"
  - Roll off the ramp without going over the side
  - Roll off the ramp smoothest
  - Roll off the ramp farthest
  - Roll off the ramp fastest

 *When we did our Cars and Ramps investigation, I picked the third one, and many of you did, too. But, someone else might want to investigate using one of the other operational definitions. We have to put our operational definition in our report so everyone knows exactly what we are investigating.*

*I will operationally define "roll off of the ramp best" to mean that the car rolls farthest from the bottom of the ramp until it stops moving.*

*Now look at your own investigation question to see if there are any words or phrases you will need to operationally define. If there are, write out what you mean in a sentence or two like the example. You may have more than just one term to define.*

*Use this format:*

I will operationally define " \_\_\_\_\_ " to mean \_\_\_\_\_.

## VARIABLES



*Scientists call all the things that change or could change during their experiment "variables." It is very useful to think of your investigation in terms of three types of variables:*

- Hand out "Investigation Design Page: Categories of Variables" and discuss the different types of variables. The terms may be confusing for students, but going over the two examples will give them an idea of the variables in their own investigations.
  - Variables where you control the change = "independent variable"
  - Variables where you measure the change = "dependent variable"
  - Variables you work to keep the same = "controlled variables"

### Dr. Pepper\* and Mentos\* Example

Variables in this investigation:

Things I will modify: I will use bottles of Dr. Pepper at different temperatures. (*This is the independent variable.*)

Things I will measure: I will measure the volume of liquid left in the bottle after the reaction. (*This is the dependent variable.*)

Things I will control: I will use the same size bottle of Dr. Pepper, the same flavor of Mentos\* and the same number of candies each time. (*These are the controlled variables.*)

### Cars and Ramps Example

Variables in this investigation:

Things I will modify: I will modify the angle of the ramp by first using one book under the ramp, then two, and finally three.

Things I will measure: I will measure the distance the car rolls off the ramp until it comes to a stop.

Things I will control: I will use the same three cars each time at each angle. I will use the same books each time. I will be sure the surface the cars are rolling on is the same each time – tile floor not carpet. I will start the cars at the same point on the ramp each time. In comparing results, I will look at how each car did at each of the three angles.

Now, identify the variables in your investigation.

- Hand out “Investigation Design Page: Variables in my Investigation” and assist students in figuring out their variables.

## STEP-BY-STEP PROCEDURES

*Examples of procedure styles*

- Give students the one-page handout titled: “Which procedure style do you find easiest to follow?” ♦ and the two-page handout titled: “Annotated Diagrams” ♦



*Look at the handout on styles of procedures. [Hold up the craft stick model] Here is the object they are trying to construct. Which kind of directions would you want to have if you were asked to build this? - sentence style, single diagram style or step-by-step diagram style?*

- Develop the point that diagrams are very helpful in explaining procedures. With complex procedures, step-by-step diagrams are a must.



*Look at the annotated diagrams and see how a few notes on a diagram can really help clarify the procedure.*

*Keep these examples in mind as you begin to make your own step-by-step instructions for your investigation procedure.*

*Now you can begin to write the step-by-step directions for your investigation.*

*Picture what you plan to do, and tell the reader what you will do one step at a time.*

*Your first step will probably be to gather the materials you need. Tell your reader what to get – don't forget to specify the size and quantity of needed items. You might want to use a table such as this.*

- Hand out copies of the “Sample Procedure Write-Up” ♦ and point out some things to students:
  - She used numbered steps.
  - She grouped the steps which were related on one aspect of her procedure.
  - She used a diagram to help explain some of the procedure.
  - She listed what to do in unusual situations.

- Her procedure looks like it takes 5 pages to present. This is not unusual.
- Refer once more to "Investigation Design Page: Variables in my Investigation" ♦ and draw students' attention to the Materials table.

Materials that will be used

Item	quantity	size



*Your next steps will tell how to assemble the materials and how to use them. Be sure to explain in descriptive steps **how you change your independent variable, how you measure your dependent variable and how you try to keep each of your controlled variables from changing.***

*You might have many steps, and your instructions might go on for pages.*

- Set the students to work writing their procedures. Monitor and encourage them. Remind students of how impressed the judges will be when they see that students' instructions are so clear that anyone else would be able to repeat the investigation just by following the written procedure.

### Teacher Tasks After the Session

- Don't expect all students to finish writing their design procedure in one session. Be sure they file all their work in their file folders.
- This week you will know how many students will be doing projects. Plan now to order boards. Shop around for best price. Doing a web search using the phrase "science fair" project display board sales, we got over 4000 hits with costs ranging from \$2.25 to \$150 each!
- Boards also can be obtained from many sources.
  - You probably have an approximate idea of the kinds of materials your students will need in order to conduct each of their investigations. Now is the time to begin to gather some of those items.

## Investigation Design Page: Operational Definitions

### Sample question:

At which angle do the cars roll off the ramp best?

### Possible operational definitions for “roll off the ramp best”:

- Roll off the ramp without going over the side
- Roll off the ramp smoothest
- Roll off the ramp farthest
- Roll off the ramp fastest

### An operational definition in your investigation design/procedure write-up might look like this:

I will operationally define “roll off the ramp best” to mean that the car rolls farthest from the bottom of the ramp until it stops moving.

### Fill in your own operational definitions in this format:

I will operationally define “\_\_\_\_\_” to mean \_\_\_\_\_.

*(You might have to use this format for more than one term.)*



## Investigation Design Page: Categories of Variables

**Variables where you control the change = “independent variable”**

**Variables where you measure the change = “dependent variable”**

**Variables you work to keep the same = “controlled variables”**

### **Dr. Pepper\* and Mentos\* Example**

Variables in this investigation:

Things I will modify: I will use bottles of Dr. Pepper at different temperatures. (*This is the independent variable.*)

Things I will measure: I will measure the volume of liquid left in the bottle after the reaction. (*This is the dependent variable.*)

Things I will control: I will use the same size bottles of Dr. Pepper, the same flavor of Mentos\* and the same number of candies each time. (*These are the controlled variables.*)

### **Cars and Ramps Example**

Variables in this investigation:

Things I will modify: I will modify the angle of the ramp by first using one book under the ramp then two and finally three.

Things I will measure: I will measure the distance the car rolls off the ramp.

Things I will control: I will use the same three cars each time at each angle. I will use the same books each time. I will be sure the surface the cars are rolling on is the same each time – tile floor not carpet. I will start the cars at the same point on the ramp each time. In comparing results, I will look at how each car did at each of the three angles.

## Investigation Design Page: Variables in My Investigation

Things I will modify (*independent variables*)

---

---

---

Things I will measure (*dependent variables*)

---

---

---

Things I will control (*controlled variables*)

---

---

---

### Materials Table

Materials that will be used

Item	quantity	size
<i>Example:</i> Test tube	2	125mm x 10 mm

## Which Procedure Style do you find Easiest to Follow?

### Sentence style

Get five craft sticks, and put three of them on the table running in parallel lines in front of you about 3 cm apart. Attach one of the other sticks in the slots provided along one end of the first three. Attach the last stick in the slots provided along the other end of the first three.

### Step style

1. Get five craft sticks.
2. Lay three of them on the table running in parallel lines in front of you 3 cm apart.
3. Attach one of the other sticks in the slots provided along one end of the first three
4. Attach the last stick in the slots provided along the other end of the first three.

### Diagram style

You are going to construct something that looks like this from five craft sticks:

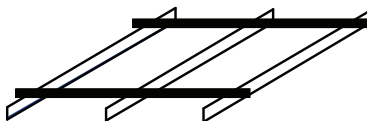

1. Get five craft sticks.
2. Lay three of them on the table running in parallel lines in front of you 3 cm apart.
3. Attach one of the other sticks in the slots provided along one end of the first three.
4. Attach the last stick in the slots provided along the other end of the first three.

### Step-by-Step Diagram style

1. Get five craft sticks.
2. Lay three of them on the table running in parallel lines in front of you 3 cm apart.

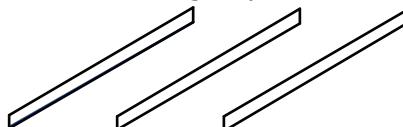

3. Attach one of the other sticks in the slots provided along one end of the first three.

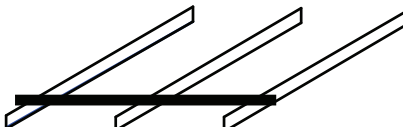

4. Attach the last stick in the slots provided along the other end of the first three.

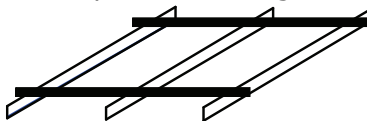

*Notice that your diagrams do not have to show the unimportant details of the actual sticks. These diagrams don't show all the notches in the sticks or the rounded ends because they are not important to the project. Also, we've shaded two of the sticks so they show up better in the diagram.*

## Annotated Diagrams

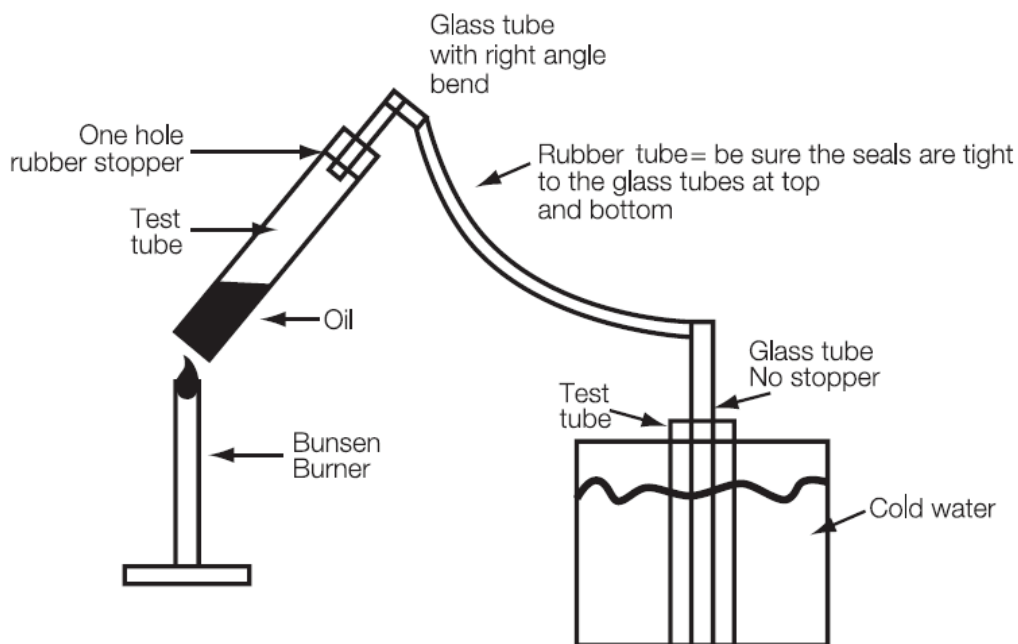

Distillation Apparatus

An annotated diagram can help you explain how your apparatus is set up or how you used it. Be sure your diagram is large enough for your notes to fit easily. Sketch everything out before you start to work on your final copy. Don't try to use too many notes. If you need to, use a second diagram with additional notes.

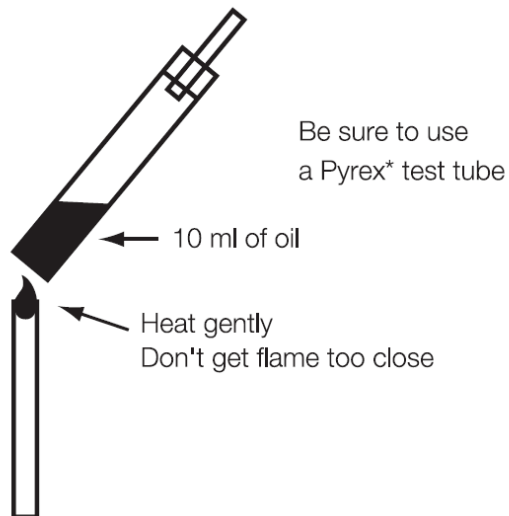

You also can use numbers to connect to your notes:

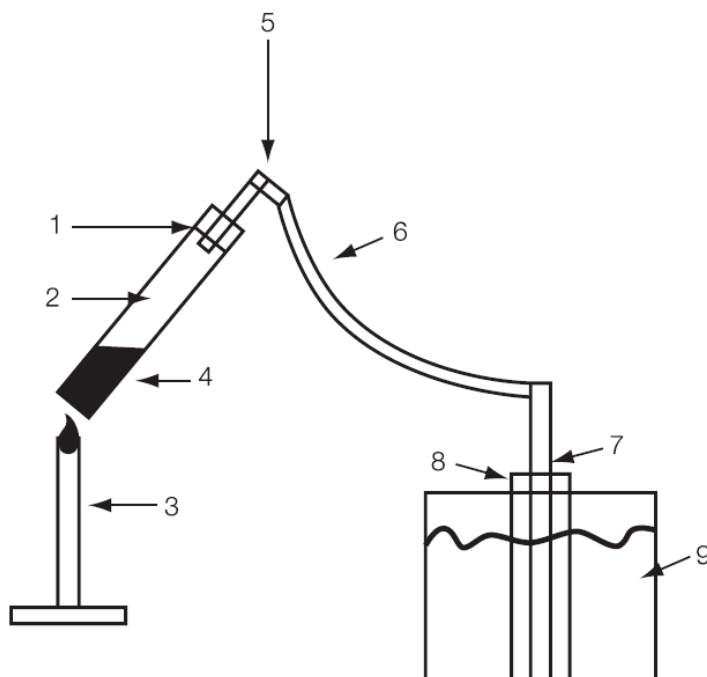

Distillation Apparatus

1. One-hole rubber stopper – be sure to have tight seals
2. Pyrex test tube
3. Bunsen burner – heat gently. Don't get flame too close.
4. 10 ml of oil
5. Right angle bends of glass tube
6. Rubber tubing – be sure to have a tight seal at top and bottom.
7. Glass tube – no rubber stopper
8. Receiving test tube
9. Cold water

*Notice how you can put more detail in numbered notes, but they may not be quite as easy to read and understand because the reader has to jump back and forth between the notes and the diagram.*

## Sample Procedure Write-Up

A sample of one student's procedure write up (5 pages total):

### **A. Organize the data takers**

1. Contact friends and family across the country to set up feeders and observe hummingbirds.
2. Give each data taker the same instructions for building the feeder and for data recording.
3. Design a data sheet.

### **B. Build the feeders**

1. Use a clear plastic bottle with a stopper and tube.
2. Mail the feeders to the data takers.
3. Fill the bottle with a sugar water mixture. Do not add any coloring.
4. Hang in the shade 6 feet above the ground within 6 feet of nearby bushes.

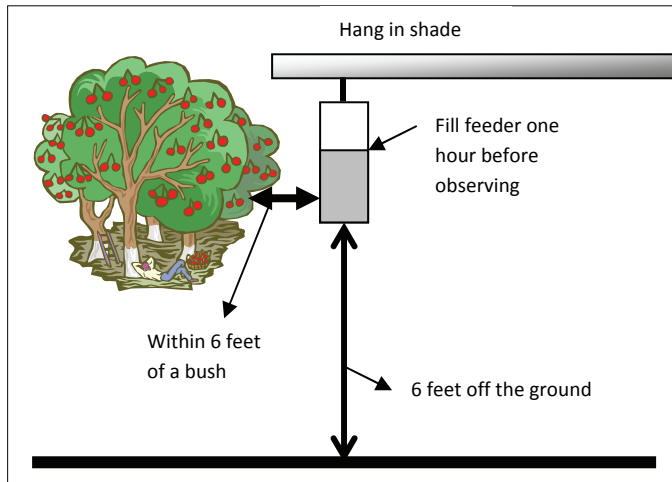

Diagrams add clarity

### **C. Take the data**

1. Observe the feeder for 15 minutes each day between 9 AM and 11 AM.
2. Do at least three observations per week for four weeks.
3. Record on the data sheet the start time, stop time and number of hummingbirds visiting the feeder in the 15 minute period.

Notice that numbered steps were used

### **D. Unusual situations**

1. Do not count any observation time where people or cats are within 30 feet of the feeder.
2. Do not count any observation time if it is actually raining during the observation.
3. Fill the feeders at least one hour before doing any observation.

Protocols for unusual situations are covered

## Week 18

### Investigation Design (continued)

**Overview** - Students continue with the investigation design tasks and work on design protocols.



Struggling students may benefit from viewing other [science fair project investigation designs](#) at Discovery Education: Science Fair Central.

#### Teacher to Teacher Background

- This session you will move forward with the lessons and tasks presented last session, allowing students time to work on their procedures and protocols.
- Don't expect all students to finish writing their design procedures in one session. Many will still have tasks from last session. Allow some "catch-up" time at the start of the meeting before you begin the lesson on protocols.
- Remember that protocols are the set of rules for conducting the investigation. These rules are found either in the step-by-step procedures or in separate protocols for handling special situations.

#### Teacher Tasks Before the Session

- Photocopy student handout – "Protocol Examples" ♦
- Make enough copies of the form "Advice on Design from your Science Coach" ♦ so you have one to accompany each student's design plan when it is sent to the Coaches for feedback. These forms offer a structure and space for that feedback.
- Also included in this session's forms is one titled, "SRC Feedback on Preliminary Design." ♦ If your SRC doesn't use a form like this, it will still help you understand typical SRC comments.
- Note: Some Intel® ISEF Affiliated Fairs have local versions of some of the forms which gather additional information. Be sure to use the appropriate forms for your fair.

#### Teacher Tasks During the Session

##### PROTOCOLS

- Post the butcher paper sheet you used to record student procedures in the first inquiry investigation, "Cars and Ramps."



*A few months ago, when we did our "Cars and Ramps Investigation," you had me write down some procedures and rules you used to give the cars "a fair test" when answering the question, "Which car goes down the ramp the best?" Your investigation design also should include rules to ensure that you are doing a "fair test" in your own experiments. Sometimes you need to make rules that cover situations beyond your step-by-step instructions. Do you remember our discussion of protocols after we investigated cars and ramps? (Remember the combination lock example?) Sometimes there were special situations we had to have procedures for?*

*You'll put the instructions for your own investigation in a section called "Procedure" when you are writing your investigation design.*

*If your investigation requires additional rules beyond just the procedure, you'll put those in a section called "Protocols."*

*I like to think of two categories of protocols - those that apply to every test (or observation) and those that apply to special situations.*

- Distribute student handout, "Protocol Examples" ♦ to give examples of the two types of protocols.

*Here are some examples of protocols that apply to every trial or observation -*

Butterfly observations:

After sitting down in the garden chair, wait 3 minutes before starting to count. This is to allow the butterflies to resume normal behavior after I've walked through the garden.

Cars and Ramps

For every test, start the cars with the rear bumper at the top edge of the ramp.

Weather observations

After emptying the rain gauge each week, dry the inside with a paper towel.

*Here are some examples of protocols that apply only to special situations -*

Butterfly observations:

If there is any loud noise or anyone walks in the garden, wait 3 minutes before restarting your count.

Cars and Ramps

If a car goes off the edge of the ramp before reaching the bottom, replace the car at the starting point and run the test again. Do not record any data.

If the car curves after leaving the ramp, measure the distance to the stopping point in a straight line from the center of the ramp.

Weather observations

If hail falls during the week, do not count the total rainfall that week.



*Think about the rules you will need to guide your investigation and keep it fair. Write these down under a heading marked Protocols, and remember to file them.*

*All the parts you've been writing (your operational definitions, your variables list, your materials, your step-by-step instructions and your protocols) together make up your "preliminary investigation design," also known as a "research plan." After you get approval for this design, you will take some sample data and make any changes that you need to before starting your actual data collection.*



## Teacher Tasks After the Session

(You will notice some of these are the same as after the last meeting.)

- As soon as this last meeting on investigation design is over, determine which student designs should be flagged to go to the SRC. These are the investigations involving any of the following:
  - human subjects,
  - animals,
  - pathogens (including any molds),
  - controlled substances,
  - hazardous substances, radioactive materials or radiation,
  - DNA,
  - human or animal tissue.

Please note that the Intel ISEF rules are revised each year, and the current version of the rules must be used. For the most current rules, contact your Fair Director or visit the Intel ISEF web site: <http://sciserv.org/isef/>

(Your SRC is a valuable resource. This group may be able to suggest ways to redesign a student's experiment to minimize the risk to subjects, thus ensuring a less complicated approval process.)

- Send all other students' preliminary designs to Science Coaches so they can begin working on coaching comments *before* your next meeting. THIS IS A QUICK TURN-AROUND TIME.
- This week you will know how many students will be doing projects. Plan now to order boards. Shop around for best price. Doing a web search using the phrase "*science fair*" project display board sales, we got over 4000 hits with costs ranging from \$2.25 to \$150 each!
- Boards also can be obtained from many sources.
  - You probably have an approximate idea of the kinds of materials your students will need in order to conduct each of their investigations. Now is the time to begin to gather some of those items.
- **NEW:** At the end of this lesson, you will find "Advice on Design from your Science Coach" ♦ that should accompany your students' designs when they are sent to the Coaches. These forms are used for giving design feedback to your students.

The last of this week's forms is titled "SRC Feedback On Preliminary Design." ♦ As explained in Teacher Tasks Before the Session, many Affiliated Fairs will be happy to advise student researchers about forms and rules. Teachers should contact the Affiliated Fair director for information. These sheets are only to let you (the teacher) know what kind of comments are typical. Fair SRC's probably have their own forms or e-mail paragraphs (or they are free to use these forms).

## Protocol Examples

*Here are some examples of protocols that apply to every trial or observation -*

### Butterfly observations:

After sitting down in the garden chair, wait 3 minutes before starting to count. This is to allow the butterflies to resume normal behavior after I've walked through the garden.

### Cars and Ramps

For every test, start the cars with the rear bumper at the top edge of the ramp.

### Weather observations

After emptying the rain gauge each week, dry the inside with a paper towel.

*Here are some examples of protocols that apply only to special situations -*

### Butterfly observations:

If there is any loud noise or anyone walks in the garden, wait 3 minutes before restarting your count.

### Cars and Ramps

If a car goes off the edge of the ramp before reaching the bottom, replace the car at the starting point and run the test again. Do not record any data.

If the car curves after leaving the ramp, measure the distance to the stopping point in a straight line from the center of the ramp.

### Weather observations

If hail falls during the week, do not count the total rainfall that week.

## Design Advice from your Science Coach

Student Name \_\_\_\_\_ Teacher \_\_\_\_\_

**One of the Coaches plans to come to advise this student.**

### 1. Operational Definitions

- The terms in the question will need clarification with operational definitions.
- Good – There is no problem with unclear terms. Everything is well-defined.

### 2. Independent Variables

Current design has too many independent variables.  
Advice:

Current design doesn't have a sample size that will support an answer to the question.  
Advice:

Good – The independent variables are fine.

### 3. Dependent Variables

Advice on measurements indicated in the design:

Advice on the need for a self-designed rating scale:

Good – The dependent variables are fine.

### 4. Controlled Variables

Advice on factors that need to be held constant from trial to trial:

Advice on how to hold \_\_\_\_\_ constant:

Good – The controlled variables are fine.

## Design Advice from your Science Coach *cont.*

Page 2

### 5. Help with equipment

- Advice on finding equipment:
  
- Advice on building equipment:
  
- Advice on using equipment:
  
- Good – This design should not have any problems with equipment.

### 6. General advice

- Advice on ideas of whom to contact for further suggestions:  
*(Please give specifics, if possible.)*
  
- Please revise this design and send back.  
*(If possible, please provide an e-mail address to which student can send design revisions.)*

### 7. Notes to teacher

- This student probably will need substantial help in collecting preliminary data.  
*(Please elaborate, if possible.)*
  
- This design probably will need significant revision after preliminary data collection.  
*(Please elaborate, if possible.)*
  
- One of the Coaches plans to come to help with preliminary data collection.  
*(Please contact the Coach at \_\_\_\_\_ to give date and time of that meeting.)*
  
- This design looks strong and probably won't need much revision after preliminary data collection.

### Additional comments:

## SRC Feedback on Preliminary Design

Page 1

Student Name \_\_\_\_\_ School \_\_\_\_\_  
Date \_\_\_\_\_

Some SRC's use standard paragraphs in e-mails or forms such as this one to give feedback to students. We are adding this form so that teachers have an idea of the types of responses that are typical.

*If the project is approved without condition,*

- This project is approved based on the research plan submitted.

*If the project is approved with specific conditions,*

- This project is approved if the changes in the research plan listed below are made.

---

---

---

---

*If the project is not yet approved and advice must be given,*

- This project is yet to be approved. Please make the changes indicated below or contact an SRC member, and then resubmit the project for SRC approval.

---

---

---

---

## SRC Feedback on Preliminary Design *cont.*

Page 2

### ***If the project involves human subjects, check one of the following:***

*If the SRC, the teacher, and the school administrator agree that the project involves minimal risk to subjects and no informed consent will be required,*

- This project has been approved by the IRB and the top box pertaining to risk level on Form 4 has been marked. No additional informed consent forms are required.

*If the SRC, the teacher and the school administrator all agree that the project involves minimal risk and informed consent will be required,*

- This project has been approved by the IRB and the middle box pertaining to risk level has been marked on Form 4. Each subject will be required to sign Form 4 in the lower left box. If the subjects are minors, their parent will need to sign in the lower right box.

*If the SRC, the teacher and the school administrator agree, the project is approved with more than minimal risk,*

- This project has been approved by the IRB and the lowest box pertaining to risk level has been marked. You will need to involve a Qualified Scientist (see Glossary in this *Guide* for details) and have that person sign Form 2 before experimentation begins. Each subject will be required to sign Form 4 in the lower left box. If the subjects are minors, their parent will need to sign in the lower right box.

### ***If the project involves non-human vertebrate animals and only involves passive observation of pets, or farm, wild or zoo animals check the following:***

*If the project is observational only,*

- This project has been approved by the SRC and has been marked on Form 5A. The “observational study only” box will be marked.

*If the project involves non-human vertebrate animals and involves more than passive observation of pets, or farm, wild or zoo animals check the following:*

- This project must take place in a registered research facility licensed by the USDA. The research will be conducted under the certificate issued by that institution’s Institutional Animal Use and Care Committee. Submit a copy of that certificate along with Forms 1C, 2,3 and 5B. With these forms the SRC will sign the right hand box on form 1B.

## Week 19

### Design Revision and Fair Forms

**Overview** - Students make modifications to their preliminary designs and prepare their Intel® ISEF Affiliated Fair forms.



Students who need to revise their investigation designs may benefit from the [step-by-step design procedures](#) outlined on the Discovery Education site.

#### Teacher to Teacher Background

- You'll want to review the rules for Intel ISEF Affiliated Fairs. For the most current rules, contact your Fair Director or visit the Intel ISEF web site:  
<http://www.societyforscience.org/isef/document>

#### Teacher Tasks Before the Session

- Sending students to an Intel® ISEF Affiliated Fair will require the use of appropriate forms. Obtain these from the Fair Director or from the Intel® ISEF web site <http://www.societyforscience.org/isef/document>.
- Be sure you know the due dates for forms at your local Intel® ISEF Affiliated Fair. The SRC and arrangements committee need much work time with the information.
- For each project, you will need a blank copy of Intel® ISEF forms 1, 1A and 1B and a Research Plan Form.
- You also will need additional blanks of the forms indicated for investigations involving:
  - A team of student investigators
    - Form 1A Team
    - for each member a copy of Form 1B
  - Human subjects
    - Form 4 – Human Subjects
    - If the SRC finds more than “minimal risk,” a copy of Form 4 with the lower left box signed by each subject will be required and, if the subject is a minor, the lower right also needs to be signed.
  - Non-human vertebrate animals
    - Form 5A
  - Human or vertebrate animal tissue
    - Form 6 – Human and Vertebrate Animal Tissues.
    - Form 3 – Designated Supervisor.

## Tasks During the Session

- Make revisions to investigation designs.
  - Have students review the comments they received from their Coaches or the SRC, if feedback forms have been returned. Help students make changes in their preliminary investigation design. Save the advice and approvals in their file folders.
  - In a few cases, certain students may not have final approval from the SRC to start data collection. These students will need to make revisions and send their revised material back to the SRC. Be sure to get these back to the SRC *as soon as possible*.
  - In other cases, the SRC will have given conditional approval if certain changes are made. Save messages of this type in the student's folder, and have the student make the changes in his/her investigation design. As soon as the changes are made, the project can be considered approved.
- After a student investigation design is revised, the student can begin to fill in the correct Intel® ISEF forms.

## Teacher Tasks After the Session

- If the SRC has not yet given approval to a student's investigation design that requires it, send the student's revisions (made at the meeting today) back to the SRC for further review.
- Except for forms you send to the SRC for further review, place the students' forms they filled in today in their file folders.
- Continue collecting materials your students will need to preliminarily test their designs next week.
- Contact your Science Coaches, Science Fair Support Volunteers and other science teachers in your building about coming in next week to help with preliminary data collection.



## Week 20

### Preliminary Data Collection

**Overview** - Students attempt to use their preliminary research design plans to collect data and then revise and annotate those designs into a final plan.

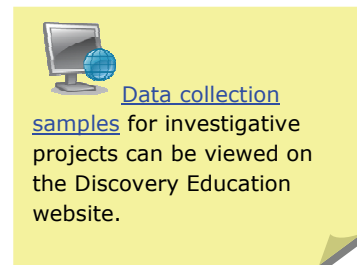

#### Teacher to Teacher Background

- This will be a very active meeting for you. (Not that the previous meetings weren't!) Every student probably will need some of your attention.
  - Those ready to start data collection will set up their investigation and begin to try to collect data.
  - Students not ready to collect data will need assistance in finalizing their preliminary plans and getting them into a usable form.
  - Students with good plans that are impractical to test now (for example, a plant growth experiment) will have to do imaginary data collection. That means mentally, methodically working through the step-by-step instructions and annotated diagrams to catch points that need clarification.
- Although you should encourage students to try taking data on a data table today, don't worry too much about the quality of the data or the quality of the data table. Let them struggle a bit with how to manage it. Offer graph paper on which they can record results. Next week focuses on refining this data table to meet their needs.
- Often students will naturally know to write down data, but they don't remember to include instructions in their procedure. For example, students observing the presence of butterflies in shade and sun might record the temperature so they can compare similar days, but if you look at their design instructions, temperature isn't mentioned. Have them watch for this error and add to their designs as needed.
- You'll also want to remind students to write down any changes they make in their plans and to write protocols to describe how they handle any unexpected situations that arise.
- Revision of design plans is something of an art. Sometimes the easiest way to revise is to add an additional step to the instructions, while at other times, it is more efficient to describe how to handle situations with short notes or rules (protocols). If the students are clear, and a reader would be able to replicate their work, almost any form is acceptable, including annotated diagrams.
- The closer to reality students get in collecting preliminary data, the clearer they will be on what instructions and protocols need to be written down. It is inherently

difficult to imagine unforeseen situations and write rules to deal with them, so scientists collect preliminary data in order to uncover these unforeseen situations. If the procedure calls for students to plant seeds, the closer they get to actually planting them, the more they will improve their designs. (For example, have students act as if they're going to plant. Get out the dirt, place the seeds at certain depth, etc., but don't actually go through with the planting.) Mark Twain said, "You can learn things holding a cat by the tail that you can learn no other way." This week, the students need to pick up the metaphorical cat! Have them view their work today as a "dry run" for next week.

### Teacher Tasks Before the Session

- Have the students' revised design plans ready for them to use, along with graph paper on which to record their preliminary results.
- This is a day you would like to have lots of adults to help. Science Coaches are a must. Request (offer chocolate?) fellow science teachers to come by to help your students with preliminary data collection. Your colleagues will be impressed with all the science going on and right away be in demand. Remind the adults that today they are helping students test their own research design plans and that *gentle suggestions and coaching* are best. Volunteers should not take over a student's responsibilities.
- Your Science Fair Support Volunteers can help with writing and typing after this meeting.
- Ensure you have adequate space and necessary equipment for all the data collection that will be going on. Today will undoubtedly surface needs for materials that were unanticipated, but the goal is to keep equipment delays to a minimum.
- Anticipate the need for cleaning supplies and storage space at the end of the meeting.

### Tasks During the Session

- We suggest you start with a reminder about some courteous ways to share the teacher's/volunteers' attention. You may want them to add their name to a list on the board if they need adult help. Also, be sure to give your attention to the students who are lost and can't even figure out that they need your attention.
- Before beginning, have students thank the adults that have come to help them.
- Tell students they are going to begin testing their research plans today. Remind them that the product they are after is a clear set of step-by-step instructions and

protocols that anyone in the room could follow to repeat their investigation. They initially can write it in the future tense because it tells their plans. (“We will plant 8 radish seeds 5 inches apart and one-half inch deep.” Or, “Hold each ball in your hand at arm’s length and even with your shoulders. When I say, ‘go,’ drop them both.”)

- Tell students to use the graph paper to record their preliminary results. Remind them that they are not recording data into a graph or graphing anything at this point; the graph paper just provides an easy grid for students to use to create a table.
- Let them know where to find the equipment they need and where to put it at the end of the meeting.
- If any students, for any reason, are not ready to try out their design plans, have these students put their names on the board to get immediate help.
- Assign those ready for data collection to different locations in room where they will work.
- Remind everyone about on-task behavior and reasonable voices. Inform them you will announce a clean-up time, will expect their help, and will look forward to gathering with them at the end to debrief.
- Start the work time and step back. Watch what goes on and who might be lost.
- Spend the rest of the time being a teacher. Talk to those with questions. Question those who need it. Encourage. Get supplies. Observe. Seek out those who don’t come to you. Enjoy today! It is the first of what everyone has been waiting for.
- About ten minutes before the end of the meeting time, start the students cleaning up. Be sure to allow time for a final gathering.
- Make sure students file their early data collection tables. They will work on refining them next week.
- Get the group together to debrief for a few minutes - not just on how their own experiment progressed, but on what they could do as a group to make things run more smoothly for everyone, including you!

## Teacher Tasks After the Session

- Check how your clean-up and storage arrangements worked today.
- Thank the adults who helped.
- When a student has finalized his/her investigation design, the student’s writing can be given to a volunteer typist for entry onto the Research Plan Attachment form.

It is best to save this as a word processing document because a few students may need to make further revisions.

- If students made significant revisions to design plans that needed SRC approval, they will have to resubmit the revisions to the SRC for final approval.

## Week 21

### Developing a Data Format and Display

**Overview** - Students work on developing a format in which to record and organize their data. They also begin to consider how they will display their results on their project boards.

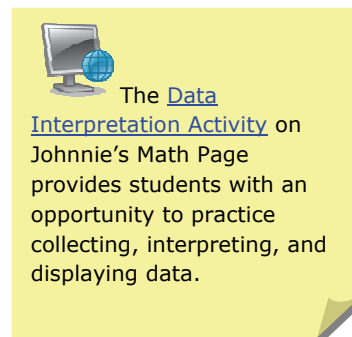

#### Teacher to Teacher Background

- For some of your students, this meeting will be spent continuing the preliminary data collection they started last week. Once they have gathered some data, they should revise their designs as necessary.
- One goal of this meeting is to develop a data table into which data can be organized when students begin the actual collection/experimentation at the next meeting. Once students have this organizational format ready, the data they collect is put into one place, is easy to analyze and is ready to be translated to presentation form. If students truly understand their investigation and the variable being measured, this step should not be too difficult.
- Last week's preliminary collection allowed them to struggle a little with how to record their data. This week they can refine those initial data formats with your help.
- Weeks 9 and 10 were designed to focus on the skill of data collection and organization. You may want to refer back to the data tables in these activities.

#### Teacher Tasks Before the Session

- Make sure the materials students need for their investigations are readily available.
- Have graph paper on hand; students may want to create their final data tables on this kind of paper.
- Make student handouts of the data tables from the exercise and temperature investigations (Weeks 9 and 10) so you can review principles of good data collection and organization.

#### Tasks During the Session

- Have students gather with their investigation designs in hand. Ask them to comb through their designs, step-by-step, to see where they tell themselves to take data. Refer to data tables from the exercises in Weeks 9 and 10 to remind

students what they are aiming for. A good data table includes the independent and dependent variables, units of measurement, a title and sufficient space in which to clearly record data.

- Work with individual students to create a data table(s) they can use for the entire data collection period of their investigation.
- When students complete filling in the data table with preliminary data, ask them to begin making a graph to display that initial data. Make sure they use a ruler and label axes. Have them consider what type of graph they may use and if there are other ways to organize the data to help the reader better understand their results. They can begin graphing their preliminary results *for practice* right now if they are ready. Remember, actual data collection doesn't begin until next week. One major reminder: If the investigation has a category as the independent variable, use a bar graph. If the investigation involves points on a continuum, use a line graph.
- Students need to consider how they will display data when they are constructing their display boards. Because too often we see students hastily graph *something* and put it on their board, we encourage you to go over the lesson materials on data transformation with your students. They need help remembering that the graphs and other graphics they use have the purpose of helping answer the inquiry question. They are not just decorations.
- **THE IMPORTANCE OF DATA TRANSFORMATION.** Show the data table on the top half of page one of "The Importance of Data Transformation" ♦ and ask students,



*Do you see any pattern that answers the question, "Do fish swim faster at higher temperatures?" (They probably won't see any patterns...)*

Show the graph on the lower part of the page.



*The student decided to use a computer to make a graph. He graphed the date and the time it took for the fish to swim. Do you see a pattern now? It is a nice graph, but it doesn't help answer the question "Do fish swim faster at higher temperatures?"*

Show the data table on the top of the second page.



*His partner decided to look at the data again and he reorganized the data table with the lowest temperature on top and the highest on the bottom of the table. Are patterns beginning to show up? Some students might see some relationship*

Finally, show the graph at the bottom of the second page.



*His partner graphed the data showing the speed of the fish and the temperature. Now do you see a pattern? Sure it's pretty easy with the right graph.*

*When you plan out your display, think about what kind of graph would help answer your inquiry question and show that on your board.*

## Teacher Tasks After the Session

- If students did not finish their data tables, try to meet with them during the week, or plan to work with them immediately at the start of the next meeting.
- When a student has finalized his/her investigation design, the student's writing can be given to a Support Volunteer typist for entry onto the Research Plan Attachment form. It is best to save this as a word processing document because a few students may need to make further revisions.

## The Importance of Data Transformation

Data as recorded by the student:

Speed of fish between two points 30cm apart				
	date	fish time seconds	fish speed cm/sec	water temperature ° C
3:45 PM	9/19/2004	15	2.0	15
7:45 AM	9/20/2004	20	1.5	10
8:15 AM	9/21/2004	16	1.9	11
5:45 PM	9/22/2004	10	3.0	22
2:15 PM	9/23/2004	17	1.8	14
6:00 AM	9/24/2004	25	1.2	5
9:00 AM	9/25/2004	12	2.5	18
8:30 AM	9/26/2004	11	2.7	18
7:30 AM	9/27/2004	18	1.7	12



Do you see any pattern that answers the question, "Do fish swim faster at higher temperatures?"

The student used the computer to make a graph:

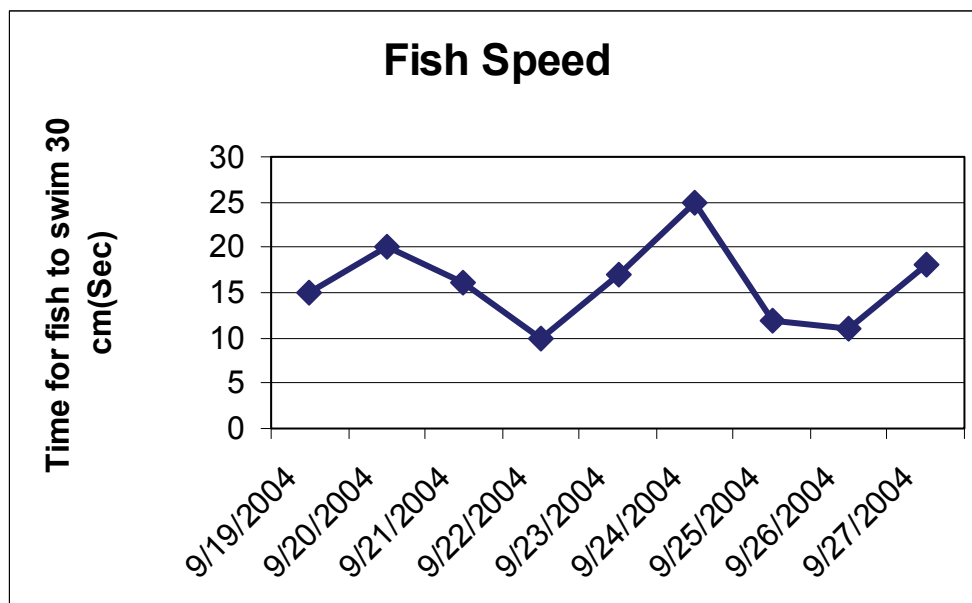



Below is the same data -- rearranged from lowest temperature to highest:

Speed of fish between two points 30cm apart				
(Sorted by temperature)				
	date	fish time seconds	fish speed cm/sec	water temperature ° C
6:00 AM	9/24/2004	25	1.2	5
7:45 AM	9/20/2004	20	1.5	10
8:15 AM	9/21/2004	16	1.9	11
7:30 AM	9/27/2004	18	1.7	12
2:15 PM	9/23/2004	17	1.8	14
3:45 PM	9/19/2004	15	2.0	15
9:00 AM	9/25/2004	12	2.5	18
8:30 AM	9/26/2004	11	2.7	18
5:45 PM	9/22/2004	10	3.0	22



*Do you see any pattern that answers the question, "Do fish swim faster at higher temperatures?"*

The student graphed the transformed data:

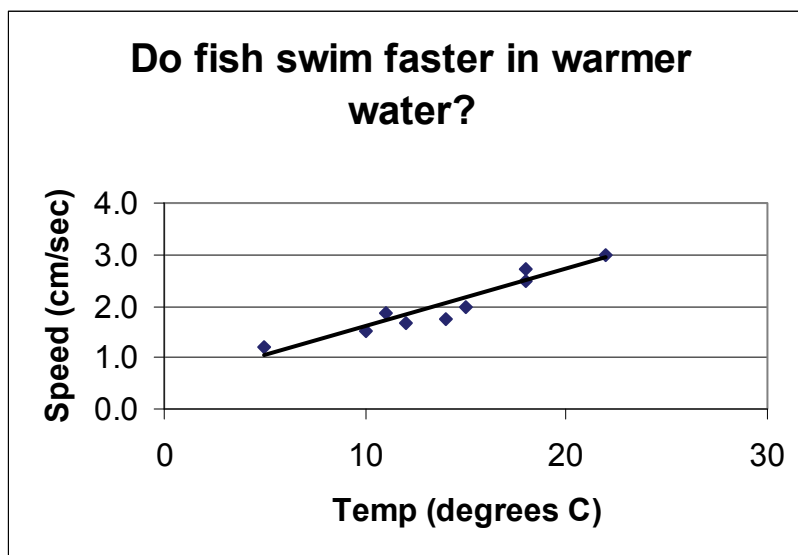

*Is the pattern even more clear?*

## Stage 4: Conducting Investigations

---

Students in this stage conduct their own investigations.

Due to the nature of research, your students will not all be on the working on similar tasks at the same time during the next several weeks. The session format may look something like this: After a group lesson, the rest of the time will find students collecting data, graphing results, engaging in problem sharing and solving, working on their abstracts, typing questions and procedures or developing their display boards. Now may be a good time to start setting aside a few minutes at the end of each meeting for students to give a brief “status report” to the group. They can share where they are in the process, what problems they are encountering and how they’re dealing with them. This teaches the collegial nature of science.

A lot of teacher guidance and support is necessary at this point, and you may be having longer meetings or meeting more than once a week. Flexibility is key! Remember to keep using your Science Coaches and volunteers.

NOTE: Have students conduct their investigations at school whenever possible so you can monitor their progress and assist when necessary in addition to ensuring that the work is theirs.

- If you are using these activities more than once a week, you should read the “TEACHER TASKS BEFORE THE SESSION” and “TEACHER TASKS AFTER THE SESSION” a few weeks ahead so you don’t get caught short in organizing needed materials and arrangements.
- If you are staging a school fair, be sure your arrangements are well underway.
- If you are taking students to an Intel® ISEF Affiliated Fair, during this stage you will want to make transportation, housing and chaperoning arrangements.

Specific notes for specific situations:

Using this *Guide* for Classroom Instruction

- Watch for notes which start “Class:” they will help you with special adaptations for classroom use of this *Guide*.
- One issue for classroom teachers will be the number of projects you will be dealing with. Student help needs, supervision, storage, materials and just space limitations are more likely to be issues than with clubs with ten students. Plan ahead.

### Using this *Guide* for an after school club

- Watch for notes which start “Club:” They will alert you to special adaptation for use of this *Guide* in after school club situations.
- Club students often have sporadic attendance. Have ways to contact students outside of meetings so that you can encourage regular attendance and shepard those parts of your flock that get lost.

## Week 22

### Investigations Begin

**Overview** - Students begin actual data collection this week using their modified designs.

#### Teacher to Teacher Background

- This is the official week students begin to collect and record actual data. This is the day it counts! Scientists call the actual data “experimental data” (versus “preliminary data”). Students still may find they need to revise their procedures and protocols further. That’s okay. Just let them know they cannot compare data taken under two different sets of instructions.
- Some students may arrive today needing help with an appropriate data table or with their design revision. Get the others started, and then you, or any Science Coaches who came to help, can work with these students.
- Today’s meeting format will be very similar to the meeting when students did preliminary data collection.

#### Teacher Tasks Before the Session

- Make sure the materials students need for their inquiry projects are readily available.
- Check to see if any of your Science Coaches or other science teachers in your building can assist today.

#### Tasks During the Session

- Have students retrieve their revised investigations designs from their files and gather materials they need for their investigations.
- Remind students about the ways they can ask for adult help (name on list, etc.), just like they did during preliminary data collection in Week 20.
- Let them know that today they are recording their “experimental data” (explain that term); but that some of them may find they need to revise their designs, even now. Reassure them that this is how real scientists work. It’s better to be methodical and careful and end up with clear procedures that lead to reliable results.
- Set students to work collecting data and assist where needed. Ask questions, encourage, retrieve supplies and observe, just as you did in Week 20.
- Encourage students to start graphing their data after they finish collecting it.
- Stop students about ten minutes before the end of the meeting to quickly debrief on successes and problems. Tell students they will have more time to complete data collection, and remind them to store ALL work in their files.
- If your schedule allows, you may want some students to come in at lunch or before school to finish with their data collection, especially if the student didn’t do any today because they were working on design revisions or didn’t have necessary forms back from SRC.

## Teacher Tasks After the Session

- How well did your clean-up and storage arrangements work today? Do you need to make any changes for the next meeting?
- Thank all adults who helped.
- When a student has finalized his/her investigation design, the student's writing can be given to a volunteer typist for entry onto the Research Plan Attachment form. It is best to save this as a word processing document because a few students may need to make further revisions.

## Week 23

### Abstract Lesson

**Overview** - Students use materials they've already prepared to begin their abstracts and continue data collection.



For additional support, [Science Buddies](#) explains how to write an abstract and provides sample abstracts for students to view.

#### Teacher to Teacher Background

- An abstract is a summary of a scientist's work. The abstracts students write will go on a specific form you'll get from your Fair Director. Their abstracts will also be pasted on their Fair display boards. (If you have a volunteer who is willing to type these for the displays, it will look neater.)
- The abstract is usually the first thing the judges read on a student's display board, and its quality determines what questions the judges ask. It is important that the abstract give these judges a quick, clear overview of the investigation.
- You may wonder why the group is working on abstracts now when an abstract cannot be finished until the students have completed their data collection and analysis. We are having them start on abstracts now, because most of the abstract is a summary of their questions and designs - two areas they have already completed. As students complete their data taking and graphing, a statement about the major trends they notice should be easy to add. Having completed their analysis (Week 26), they can add a sentence or two about the answer to their investigation question.

#### Teacher Tasks Before the Session

- Make student copies of the worksheet "Developing Your Abstract" ♦
- Make student copies of the handout "Parts of an Abstract" ♦

#### Tasks During the Session

- Use the handout "Parts of an Abstract" to help the students see the parts of the sample abstract.



*Scientific investigations can be very complex. In order to help people understand them, scientists write a short summary (called an abstract) of their work. It quickly tells these four things...*

- Draw students' attention to the four components of an abstract.



*Here are the four parts of an abstract. And, here is an example of how one student has written hers. Let's read it and notice that the paragraphs in her abstract correspond with the parts listed above it.*

- Give each student a copy of the worksheet "Developing Your Abstract." Guide students through the worksheet as they begin to develop their abstract paragraphs.
- Have students add their abstract worksheets to their file folders.

## Teacher Tasks After the Session

- At the point a student has finished writing an abstract, the student's writing can be given to a Science Fair Support Volunteer typist for entry onto the Abstract Form.
- Be sure to save the abstracts in the students' folders as student-handwritten forms or as typed forms prepared by volunteers.

### **A few words about spelling and grammar...**

- Judges (and fair-goers) receive a first impression about the student scientist's attention to detail by the care the student devotes to spelling and grammar in paperwork and on display boards.
- If you (or volunteer typists) are using word processors, be sure to spell-check all Fair paperwork *and also re-read it for punctuation and word usage errors*. If students are handwriting their paperwork, a proof-reader still will have to check for mistakes.
- Printers have a saying that, "The largest errors are made in the biggest type!" Carefully check spelling and punctuation on the headlines and banners students use on their display boards.

*Help students put their best foot forward!*

## Parts of an Abstract

- **the purpose of the experiment**
- **the procedures used**
- **the results**
- **the conclusions**

### Sample Abstract

I read that oil from outboard boat motors kills plants along rivers. I wanted to see if typical plants from the Willamette River were affected.

I went to some riverside marsh lands and collected two samples each of five types of plants. My reading told me that engine exhaust contained about 2% oil, so I prepared some water mixed with 2% oil and I tried to grow one of each type of plant in that. I tried to grow the other plant of each type in pure water.

For three weeks, I grew the plants and photographed them every week. At the end of the time I measured the height of the plants and then dried them and measured their weight. All of the plants grown in the oil mixture either died or were much smaller than those grown in pure water.

I can see from my results that for the five types of plants I used, oily water kills or reduces growth. It would be interesting to try other plants (such as trees) and use a longer growing time to see if the results are similar.



## Developing Your Abstract

The student in our example did a good job writing her abstract. In the first paragraph she has a very short description of the problem. Take a moment and write a sentence or two about your investigation. What did you study? What did you want to find out? Write your **purpose statement** here:

---

---

---

From our sample abstract, we see the next part is to briefly explain your method of investigation (**procedure**). Don't give all the details here, but do tell the basics of what you did, what you worked to control and what you measured.

---

---

---

The next step is to briefly discuss your **observations and results**. Be especially careful to include results that led you to the conclusion you draw in the last part of your abstract. Tell just the general trends of your results here, not many specifics. Don't use tables or graphs right now, rather just mention the important generalities.

---

---

---

The last part of the abstract is your **conclusion**. You set out to answer a question; now use your results to answer it. If you can think of some extensions of your investigation, mention them - even if they aren't something that would be practical for you to do yourself. (The student in the example didn't expect to plant trees herself. She just said that it would be interesting if someone did.)

---

---

---

## Week 24

### Transforming Investigations into Displays

**Overview** - Students transfer their notes to a display board.



Show students sample display boards to get their creative juices flowing!

- [Science Fair Central](#)
- [Science Buddies](#)

#### Teacher to Teacher Background

- Remember, it's likely that your students will not all be at the same place in their investigations. Expect some students to be collecting data while others work on their abstracts or type up their questions and procedures. Students will learn about putting together a Fair display board at this week's meeting.
- It helps to have the major headings of the display board already typed in a large, easy-to-read font that can just be glued on the board above the appropriate text.
- You might have a design professional volunteer come in to talk to students about graphic displays. (e.g., how visual clues like graphs convey information in just a glance, use of color, etc.)
- Now is a good time to have students revise their investigation design into its final form. We suggest they write the final form in the past tense because this helps them think about what they actually did with all the modifications they made along the way. They'll need to convert the language of their design into past tense before they print their final design for their display board.

#### Tasks Before the Meeting

- Assemble:
  - several copies, in large font, of the major display board headings:  
**Question, Hypothesis, Procedure, Results, Conclusion**
  - blank science fair display boards for each student
  - glue, scissors, colored markers, rulers, colored paper and students' work folders
  - a few good examples of display boards from other fairs
- Make student copies of handout, "Sample Display Board."◆
- Make enough copies of handout, "Tips for Helping Students with Displays"◆ to give to both volunteers and students at the meeting.
- This is a good day to have volunteers at your meeting. Check if your school's art or graphics teacher also might be available to help.
- Check availability of computers for typing.

- Note: Everything that will go on the display board **must first be photocopied** and placed in the student folder. Later, the copies will go into a binder that accompanies the project to the Fair.
- Familiarize yourself with Intel® ISEF rules for display boards, and contact Fair Director if you are unsure about anything.
- Important for fair display rules:
  - Credit *all* photographs (including those cut from magazines, etc.) on a display board with their origin.
  - If you include photographs of people other than the investigator, then permission must be given.
  - A parent's permission *must be* obtained to display photographs of minors.
  - No brand names may be displayed [Some local fairs make an exception for middle school product testing and comparison projects.]

## Tasks During the Session

- Say to students,



*Your display is going to "talk" to the judges about your investigation even before you do! Judges will read it over in the morning before they interview with you. Your display needs to tell a clear story about your investigation.*

- Show each student examples of a good display board, if available.
- Give each student copies of the major headings (Question, Hypothesis, Procedure, Results and Conclusion) and a copy of "Sample Display Board." Say,
- Your display board should use pictures, diagrams, tables, graphs, and text to tell a clear story about your work. It shouldn't be too crowded or too busy in appearance. There should be an easy-to-find title. The story of your investigation should flow clearly, probably starting in the upper left part of the board. If the flow is complex, use section titles or even numbered steps to help the judge.
- Students get their folders containing all their notes (questions, hypothesis, design write-ups [procedures], etc.), some of which already may have been typed.
- Match students to volunteers to start the typing process. Some students may be proficient typists and work on their own.
- As before, students will proceed at various rates. This is probably a time to take a step back and observe. It will become apparent now that some students will need more of your help than others!

## Teacher Tasks After the Session

- No time to relax now, but you will want to step back and take a “status of the class” accounting. Which students are going to need significant help to make it to Fair Day? Which volunteers can be called upon to mentor those specific students through to the end? How can you organize your Science Fair Support Volunteers most effectively with the remaining time and tasks you have left?
- At the point a student has finished writing an abstract, the student’s writing can be given to a Science Fair Support Volunteer typist for entry onto the Abstract Form.

## A Sample Display Board

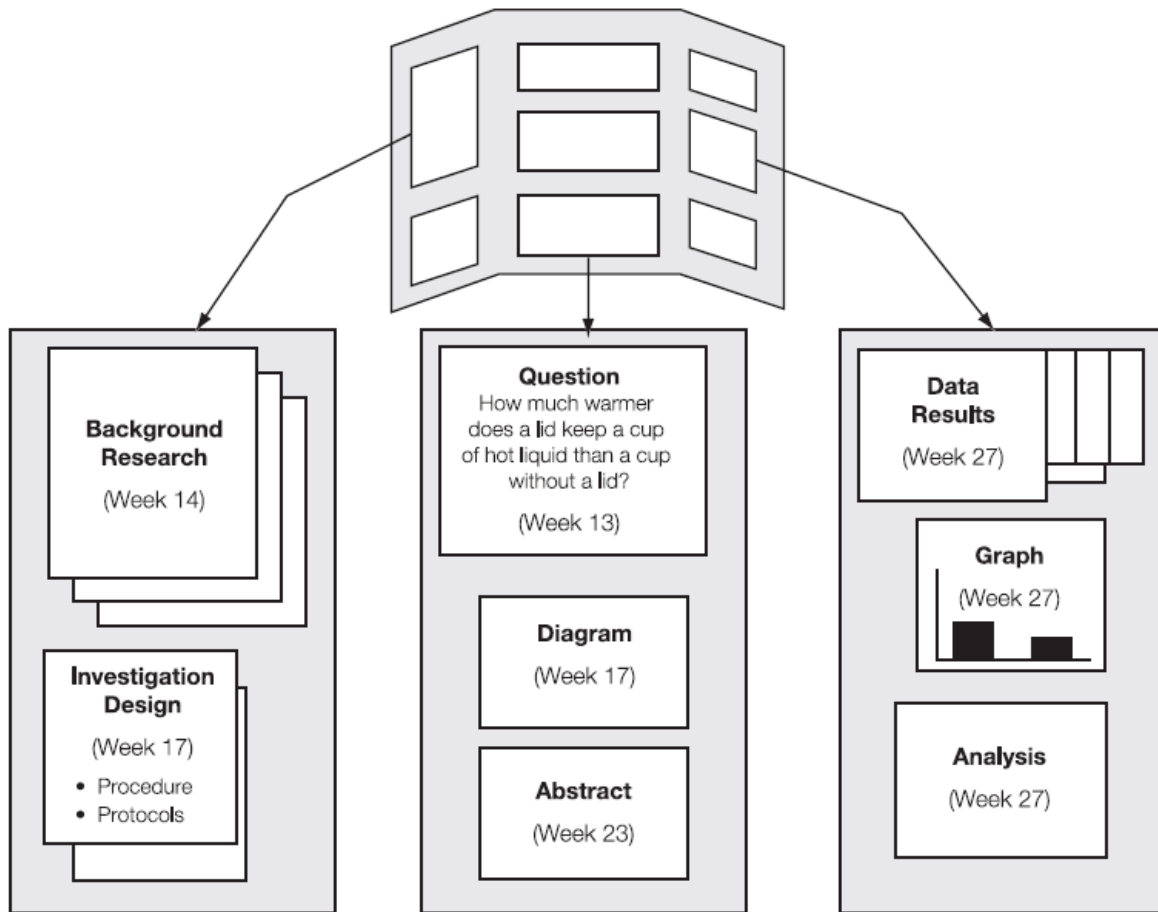

## Tips for Volunteers Helping Students with Displays

Students will need the most help with the following:

- **TYPING:** This can be done from the notes and worksheets in their folders, or they can dictate to you. Remember you must use their words; avoid writing it for them.
- **CUTTING, GLUING AND MOUNTING:** Remember that text boxes stand out when backed by a border. Edges should be neat and even. You'll probably want to help the student with measurements for aesthetic placement.
- **APPROPRIATE PLACEMENT OF WORK:** Make sure students arrange their work under the relevant headings: **Question, Hypothesis, Procedure** (step-by-step design plan and diagrams), **Results** (in some visual format, such as a graph; data tables may also be displayed) and **Conclusion**.
- **PHOTOGRAPHS:** Help students select relevant photographs, but discourage them from using them primarily as decoration.. As a general rule, judges are not impressed by photographs cut from magazines or downloaded from the internet. Fair display rules require *all* photographs on a display board (including those cut from magazines or downloaded) be credited with a statement of origin. For example: "All photos taken by the investigator." Or, "Photo: Scientific American, March 2004." Or, "Photo taken by Mark Brown, investigator's father." A parent's permission *must be obtained* to display original photographs of minors.

A final assessment: Look at the display board. Is it easy to understand and follow? Is the lettering neat? Are the tables and graphs drawn with rulers, and do they accurately display the data? Does the display use color effectively? Does it look like the scientist cares about helping others understand the project?

### A few words about spelling and grammar...

- Judges (and fair-goers) receive a first impression about the student scientist's attention to detail by the care that person devotes to spelling and grammar in paperwork and on display boards.
- If you (or volunteer typists) are using word processors, be sure to spell-check all Fair paperwork and also re-read it for punctuation and word usage errors. If students are handwriting their paperwork, a proof-reader still will have to check for mistakes.
- Printers have a saying that, "The largest errors are made in the biggest type!" Carefully check spelling and punctuation on the headlines and banners students use on their display boards.

*Help students put their best foot forward!*

## Week 25

### Work on Display Boards

**Overview** - Students work on their Fair displays and other investigation tasks.



Show students sample display boards to get their creative juices flowing!

- [Science Fair Central](#)
- [Science Buddies](#)

#### Teacher to Teacher Background

- There is no specific lesson or activity for students this week. Remember that the meeting will operate in a flexible, workshop-type format. The room should have a purposeful hum to it.

★ **Final Details:** Starting this week, you'll notice starred items in the Teacher Tasks After the Session section. The stars highlight the final logistical details that need to be accomplished in preparation for Fair day. If you follow the recommendations in the weeks they are given, it won't be crunch time at the end. (Your energies can be better spent assisting students with last-minute Fair project concerns!)

- Use the bullets below to write in tasks you need to accomplish this week.

#### Teacher Tasks Before the Session

- 
- 
- 
- 

#### Tasks During the Session

- 
- 
- 
- 

#### Teacher Tasks After the Session

- At the point a student has finished writing an abstract, the student's writing can be given to a Science Fair Support Volunteer typist for entry onto the Abstract Form.

★ **Final Details:** You should know from your Fair Director by now both the deadline for and method of sending all your student paperwork to the SRC for *final* approval. This can be done after the students finish data gathering but before they have finished their displays. The SRC probably will need the paperwork a few weeks before the Fair. Mark the deadline on your calendar!

## Week 26

### Analyzing Results

**Overview** - This week students will prepare the analysis section of their investigation write-ups.

#### Teacher to Teacher Background

- By now the students should have completed their data collection and have produced some form of visual data summary such as a graph.
- Be sure that students answer their question and draw support for their answers from their results. Encourage them to be obvious, not subtle, in their support. It is all too common for judges to encounter unsupported answers.
- It is often very difficult for early adolescent scientists to dispassionately study a hypothesis. Instead of, "My hypothesis was supported," judges often see, "I was right" or even, "I won." Help your students learn to make detached, neutral statements in their conclusions. (Scientists we work with tell us that even graduate students are not immune to some degree of attachment to a particular outcome in their research.)
- Error analysis and discussion of limitations are sophisticated concepts, especially for middle school students. More competitive entries in middle school science fairs will have such analyses alongside their conclusions. However, if your students have great difficulty with this type of analysis, it is fine for them to just draw conclusions.
- If you plan to hold a school science fair in Week 30 for students to practice their presentations and for parents and other students to see their work before going to the actual Intel® ISEF Affiliated Fair, begin your plans now. See Stage Five's intro page, "Staging a School Fair."
- Please take a moment to think back to October when you started with this group of students. With your hard work and enthusiasm, the students have learned to clarify a question, design an investigation, collect data, answer a question based on their results, and support their answers. These skills are not only important in science but in life as well!
- Take time over the next few weeks to congratulate them (and yourself).

#### Teacher Tasks Before the Session

- Have available to the students the graphical data summary they produced after they collected their data sometime between Week 22 and now. Their data summary may be a graph, diagram or some other format that allows them point



out the trends in their data. They also will need to look at their question and hypothesis as they work.

- Prepare handouts: "Parts of an Analysis," ♦ "Sample Analysis" ♦ and "Sentence Starters for Your Analysis." ♦

## Tasks During the Session

- After the students have gathered and settled, let them know that today they will begin the final work on their write-up. This is the point they've been working towards. A little cheerleading isn't inappropriate and can be helpful, because today's work could be anti-climactic for some students.

 *Today, you are going to use your data to answer the question you chose to investigate months ago. We'll discuss how scientists analyze their results and arrive at their conclusions, and then you'll write an analysis of your results.*

*An analysis has three parts.*

- Distribute student handout – "Parts of an Analysis" ♦

### Parts of an Analysis

- Conclusion: Answers your research question and tells if your hypothesis was supported or not
- Error analysis: Examines the sources of error in your work
- Limitations: Discusses the limitations of your investigation

*Let's look at one student's example.*

- Distribute student handout – "Sample Analysis" ♦

### Sample Analysis

 *Look at the first section. Notice how the investigator supported the answer to her question by telling what the results in her study showed her. Be sure you do that. Don't just give the answer to your question - be sure to back it up.*

Conclusion: My research question was "Do butterflies spend more time in the shade or in the sun?" After my observations, I can see they spend more time in the shade. In my data, the butterflies I observed were in the shade 65% of the time and in the sun 35% of the time.

 *You started out to investigate a hypothesis. Your work is successful no matter if your results support your hypothesis or not. Scientists often find it more interesting to end up with their hypothesis not supported than to have it turn out as originally*

*expected. They get very curious as to why the unexpected happened and are often spurred on to do further research. Your conclusion should state clearly whether or not your hypothesis was supported. Let's look at the example.*

My hypothesis was, "In a situation where there are about equal amounts of available sunny and shady space, butterflies will spend more time in the sun." My data shows that this hypothesis is not supported.



*Next, you'll write about things that you couldn't control even though you did your very best work. A good scientist works to identify anything that may interfere with the accuracy of results even if he doesn't have a way to control those sources of error.*

Error analysis: In doing my observations, it was sometimes difficult to see the butterflies in the corner of my yard to see if they were in the shade or in the sun. I think this was a problem in only about 10% of my observations. Another error was that my protocols said to tally data at the end of every 2 minutes. Sometimes, the butterflies spent almost the whole time in the sun and then went into the shade just before it was time to tally. Of course, sometimes it was the other way around. I think taking data every minute might have been more accurate.



*Finally, help your reader know that you know not to over-generalize your findings to new situations. Talk about the limits of your investigation. Here's how the girl did it in her butterfly example.*

Limitations: My data was taken in the spring, and our temperatures were cooler than they will be in the summer. The results of my observations might be different at different times of year. During my observations, only two kinds of butterflies visited my yard. Results could have been different for different species. The butterflies might have been influenced by something in my yard and a more complete study would take data in more locations.



*Here is a list of sentence starters to help you with writing your conclusion and analysis.*

- Distribute student handout – "Sentence Starters for Your Analysis" ◆

## Sentence Starters for Your Analysis

**My research question was** \_\_\_\_\_

**My hypothesis was** \_\_\_\_\_

**My data shows that this hypothesis is supported. (Give example.)**

**=or=**

**My data shows that this hypothesis is not supported. (Give example.)**

*Now, start writing the Conclusion part of your analysis. It is just fine to use the exact words from above in your write-up.*

- Show sample analysis on student handout "Sample Analysis" ♦

*These next starters might help you with the Error Analysis section.*

**One thing I was not able to control was** \_\_\_\_\_

**Another thing I was not able to control was** \_\_\_\_\_

*And, something like this might be used when you write about the Limitations of your investigation.*

**Someone shouldn't over generalize my results because** \_\_\_\_\_

**Results might change if someone used different** \_\_\_\_\_

**Results might change if** \_\_\_\_\_

## Teacher Tasks After the Session

- When the students have completed their analyses, the final parts of their abstracts and display boards can be produced. A Science Fair Support Volunteer typist can word process the students' handwritten work into computer files to be printed for the files/binder and display boards.

★ **Final Details:** Start soliciting and contacting chaperones for the Fair trip. Expect to have all chaperone arrangements finalized by Week 29.

## Parts of an Analysis

### **Conclusion:**

Answers your research question and tells if your hypothesis was supported or not

### **Error analysis:**

Examines the sources of error in your work\*

### **Limitations:**

Discusses the limitations of your investigation\*

*\*may be optional*

## Sample Analysis

Conclusion: My research question was “Do butterflies spend more time in the shade or in the sun?” After my observations, I can see they spend more time in the shade. In my data, the butterflies I observed were in the shade 65% of the time and in the sun 35% of the time.

My hypothesis was, “In a situation where there are about equal amounts of available sunny and shady space, butterflies will spend more time in the sun.” My data shows that this hypothesis is not supported.

Error analysis: In doing my observations, it was sometimes difficult to see the butterflies in the corner of my yard to see if they were in the shade or in the sun. I think this was a problem in only about 10% of my observations. Another error was that my protocols said to tally data at the end of every 2 minutes. Sometimes the butterflies spent almost the whole time in the sun and then went into the shade just before it was time to tally. Of course, sometimes it was the other way around. I think taking data every minute might have been more accurate.

Limitations: My data was taken in the spring, and our temperatures were cooler than they will be in the summer. The results of observations might be different at different times of year. During my observations, only two kinds of butterflies visited my yard. Results could have been different for different species. The butterflies might have been influenced by something in my yard and a more complete study would take data in more locations.

## Sentence Starters for Your Analysis

My research question was \_\_\_\_\_

My hypothesis was \_\_\_\_\_

My data shows that this hypothesis is supported.

=or=

My data shows that this hypothesis is not supported.

My conclusions \_\_\_\_\_

One thing I was not able to control was \_\_\_\_\_

Another thing I was not able to control was \_\_\_\_\_

Someone shouldn't over-generalize my results because \_\_\_\_\_

Results might change if someone used different \_\_\_\_\_

Results might change if \_\_\_\_\_

## Week 27

### Work Continues...

**Overview** – Students continue work on their analysis write-ups, as well as any other component of the inquiry process they need to finish.

- Use the bullets below to write in tasks you need to accomplish this week.

#### Teacher Tasks Before the Session

- 
- 
- 

#### Tasks During the Session

- 
- 
- 

#### Teacher Tasks After the Session

- When the students have completed their analyses, the final parts of their abstracts and display boards can be produced. A Science Fair Support Volunteer typist can word process the students' handwritten work into computer files to be printed for the files/binder and display boards.

★ **Final Details:** By this time, based on information from your Fair Director, you should have:

- city street maps or other information you will need to help the bus driver locate the Fair site;
- building maps showing the part of the exhibit area you and your students should report to upon arrival at the Fair;
- information about what to do if a student gets lost at the Fair;
- information about getting translators, if needed, for your students when they are interviewed by Fair judges;
- information about how student display boards are getting to the Fair;
- food arrangements for your students on Fair day;
- housing arrangements for you and your students if the Fair is in a distant city.

**If you do not have these details, contact your Fair Director NOW. Ask your administrator to help with these calls if necessary. You will need this information next week to send home with permission slips.**



## Week 28

### Finish Displays

**Overview** - Students begin finishing all parts of their displays this week.

#### Teacher to Teacher Background

- As students finish their displays this week, they can view the movie *October Sky* (if it wasn't shown in its entirety earlier in the year).
- Use the bullets below to write in tasks you need to accomplish this week.

#### Teacher Tasks Before the Session

- Rent the movie *October Sky* if you plan to show it to students who have completed their projects.
- 
- 
- 

#### Tasks During the Session

- 
- 
- 

#### Teacher Tasks After the Session

- When the students have completed their analyses, the final parts of their abstracts and display boards can be produced. A Science Fair Support Volunteer typist can word process the students' handwritten work into computer files to be printed for the files/binder and display boards.
- ★ **Final Details:** Prepare a detailed information sheet for families to send home with students' Fair permission slips, and show it to your administrator. Include information on:
- the time at and location from which buses depart your school;
  - appropriate attire for Fair day (dressing up is recommended);
  - appropriate and inappropriate things to bring on the trip;
  - food arrangements for the entire time the students are away;
  - housing arrangements if the Fair is in a distant city;
  - information on how to contact the school in case of an emergency;
  - the time and location of the buses' arrival on the return trip;

- expectations for pick-up of students at the end of the trip - You may even want to parents to write their arrangement for pick-up somewhere on the permission slip. (Let them know that any special arrangements must be approved before the trip.)

★ **Final Details:** Pass out the permission slip forms (along with the informational letters) for the trip to the local Intel® ISEF Affiliated\_Fair so they can be returned, *at the latest*, by Week 31.

## Stage 5: Getting Presentations Ready for the Fair

---

From now until the affiliated Fair, students will prepare to meet Fair judges and the public.

- If you are using these activities more than once a week, you should read the "TEACHER TASKS BEFORE THE SESSION" and "TEACHER TASKS AFTER THE SESSION" a few weeks ahead so you don't get caught short in organizing needed materials and arrangements.

### Specific notes for specific situations:

#### Using this *Guide* for Classroom instruction

- Watch for notes which start "Class:" they will help you with special adaptations for classroom use of this *Guide*.
- Organizing 150 students with projects can be quite an experience! Hang on. Work to have students take some responsibility for things they can do. Put students in charge of getting projects out and storing them. Pair students to practice presentations. Use peer editing for looking at writing. Have a student monitor or parent volunteer keep track of field trip permission forms (but you check up!)
- As students feel the time pressure at the end of the process, be sure that production and display materials are available in quantity. You don't want students delayed by lack of glue.

#### Using this *Guide* for an after school club

- Watch for notes which start "Club:" They will alert you to special adaptation for use of this *Guide* in after school club situations.

#### Things to note if you conduct a school fair

For students new to the inquiry process, participating in a school fair is a great first experience. Conducting a school fair is a huge undertaking and the event should be well planned. Once students have experienced a school fair, we strongly encourage teachers to take them to the next level, a regional or local Intel® ISEF Affiliated Fair.

If your school has never conducted a school-wide fair, start small with just one or two grades, or even just your classroom. Be sure to invite others in your school to visit your small fair so that excitement about participation next year is generated. Start small and build! It is important to contact teachers or parents who have staged school fairs and learn from them. They will have great advice. Try to visit some other fairs to gain ideas. Also see Appendix C "Resources" of this *Guide* for some web addresses with helpful information.

- **Approval:** Make sure your science department head and administrator are willing to support you on the endeavor. You need to inform them early on of your plans and get the event on the school calendar so that conflicts are avoided.
- **Who will participate?** You will have to decide early on who is going to be involved in the fair. Teachers who commit now may need some reminders along the year. Planning your numbers now will set the stage for other planning considerations.
- **Location:** Where will you hold the fair? Depending on the number of participants, you will have to plan a space that will accommodate your projects. Get in touch with the person in your building to secure a location and get assistance with set-up and take down. You will need tables on which to display the projects and nametags of participants on the table where they will display.
- **Display Boards:** There are many types of display boards to choose from. Order early and you can save some money. Does your budget include money to supply the boards or will students have to provide their own? There are display rules for Intel® ISEF Affiliated Fairs. Once the students are ready to organize their displays, you will want to have computers available for typing and printing. Students will also use a considerable amount of glue, and colored paper.
- **Investigations:** Undoubtedly, your students will design questions that require some consumable supplies. A shopping list from their combined materials lists will need to be made and early shopping done. You will need to determine the source of funding for these supplies.
- **To Judge or Not to Judge:** For a first year fair, you may want to hold an exposition of projects rather than a competitive fair. In this situation, the reviewers will make comments to each student, but not try to pick award winners. After this first year however, students are ready for judging and should be accountable to discuss their research and findings. This is a rich part of inquiry. Once you decide to judge the fair, you must consider the following:
  - Will you categorize projects or judge them all together?
  - How many awards will be given?
  - What criteria will be used to judge the projects?
  - Who will judge?
  - Who will organize the judges?
- Although these seem like large tasks, once you have people in place, they will typically return to judge year after year. Use local industries with trained scientists,

university personnel, and other professionals in your area. You will need to have a volunteer help to organize this part of the fair.

- Plan to order ribbons or other forms of recognition early in your planning.
- **Database:** Plan to have a volunteer create a database of student names, projects titles, teacher name and grade of student. This database can be merged onto the judging pages and can generate labels for your display.

## Week 29

### Presentations

**Overview** - Students practice presenting their projects in preparation for the Fair.



This may be the first time your students have given an oral presentation. Direct them to view [Tips for Giving an Oral Presentation](#) on the Discovery Education website.

#### Teacher to Teacher Background

- Judges will spend a significant time looking at the student's display before the student meets the judge. The display needs to be self explanatory. Judges will meet with the students later in the day and judges will often have questions developed based on their earlier time with the displays without the student.
- On the day of the Fair, students are expected to stand by their displays and give brief presentations about their projects before answering questions from Fair judges.

#### Teacher Tasks Before the Session

- Arrange for available adults (Science Coaches, other science teachers in your building, Science Fair Support Volunteers) to help students with their presentations.
- Photocopy "Tips for Helping Students with Presentations"♦ for your adult volunteers.
- Photocopy "Sample Judging Questions"♦ for students and adult volunteers. (Student may want to take question sheet home to practice with family.)
- Have index cards available on which students can write key points of presentation.

#### Tasks During the Session

- Begin this meeting by telling students something like the following:



*You'll wait quietly next to your display as the judges talk to other students. Then one or two of the judges will come to you, introduce themselves and ask something like, "Please tell us about what you did." This is the time for you to make a brief presentation about your project. After that, the judges will ask you a few questions.*

*There are two questions that most students hear from judges. One is, "Why is your research important?" - Try to be ready with an answer about how your research conclusions might help someone or how your research design might be used in similar situations.*

*The second type of question often heard is, "If you had time how would you expand your research? What additional questions come up from what you've done?" Try to have some ideas about how you or someone might follow up your work. What would you look at next? What similar questions would you investigate?*



*You'll want to practice what you are going to say to explain your work, but don't try to memorize a speech. The best way to prepare is to explain your work to as many adults as you can. You will be amazed at how much better you get after just a few tries. It helps to go over the parts of your abstract (question, procedure, results, conclusions) and talk about them in order. And remember, your judge will have a science background, but maybe not in the area of your project. So be sure to start with basics. It is quite possible that you know more about your specific subject than the judge does!*

- Distribute note cards on which students can write key points to remember while they practice. Any volunteers present can help them with the process. If you have team projects, say,



*Teams need to work out who will talk to the judge about which part of the presentation. Be sure the judge gets a chance to know that both of you understand the project.*

- Pair students with a peer or an adult and let them practice presenting. Emphasize speaking skills such as eye contact and a confident, well-paced (not too fast) delivery. Reassure them about the Q & A part of this.



*If the judge asks a question you can't answer, that's OK. You are not expected to be an expert in all science; you are only expected to have a middle school level understanding of your particular investigation.*

- Encourage volunteers and peers to offer constructive feedback to the presenters and to ask the presenters some questions from the "Sample Judging Questions" sheet. ♦ It is especially valuable for students to practice asking questions of other students with similar projects.
- Mix and match presenters and volunteers/peers so that every student gets a chance to practice with a few different people. Each student should practice at least 3 times during this meeting.
- This is a good opportunity to observe students, recording both the positives and negatives of their presentation - areas in which you can offer feedback.

## Teacher Tasks After the Session

- Save the teacher observations to use next week in offering constructive feedback to students. Students will practice their presentations over the next few weeks. You may have each student present to the whole group if time allows.

★ **Final Details:** Expect to start receiving permission slips from parents and recording them. All permission slips should be returned by the end of this week. You'll need to telephone those families that haven't sent them back.

★ **Final Details:** Finalize chaperone arrangements for the trip.

## Tips for Volunteers Helping Students with Presentations

Students will need the most help with the following:

- Making short notes on index cards - Be brief; notes should give just enough information to jog memory about what student wants to say
- Using and referring to their board as they talk - The students should talk in sequence *as it appears on their board*. If they have arranged their work non-sequentially, then they should consider numbering their display components to help the flow of their presentation.
- Eye contact and voice projection
- Keeping their presentation to a reasonable length

After the students have conducted a brief presentation, you should ask questions from the "Sample Judging Questions."

Most Judges will ask these two questions and others (students should expect something similar to these two)

*"Why is your research important? How could your findings be used?"*

And,

*"How would you expand your research? What questions would you investigate next?"*

Finally,

- Ask students what they thought they did well and what could be improved.
- Give some positive feedback!



## Sample Judging Questions

Below are listed some sample questions that a judge might ask during an interview with a student. (Please note that not all of these questions will be relevant to all projects.)

### **Framing the Question:**

What prompted you to choose this topic?

What is the question that you wanted to answer?

What type of research did you have to do before you began the experiment?

Did you make any initial observations or do any other experiments before you began?

How/Where did you research the scientific principals that your project is based on?

Do you have a hypothesis?

### **Designing the Investigation:**

Please describe for me what you did for this project.

What are your controls? What are your variables?

What materials did you used? Did you have to purchase or make any of your equipment?

Did you have to modify your procedure as you did the experiment?

How did you deal with unusual situations while taking data?

### **Collecting and Presenting Data:**

How did you organize the information/data that you collected?

Why did you choose this type of graph/chart to represent your data?

How long did you spend gathering data?

How many trials (tests of the same experiment) did you run?

Was there any "weird" data that seemed out of ordinary? Did you choose to include it?

If so, how do you explain it? If not, why did you choose to not include it?

How did you measure your data? What units of measurement did you use?

### **Analyzing and Interpreting Results:**

Did you make any calculations using your data?

Could you see any patterns in your data?

What did you learn as a result of this project?

Does your data support your conclusion?

What were your sources of data?

What could you do to eliminate sources of error if you were to do this project again?

Did you discover something that you would like to learn more about?

Were there any results that surprised you?

If you could continue this project, what would you do next?

## Week 30

### Practice Presentations – Prepare for the Fair

**Overview** - Students continue practicing for the Fair.

#### Teacher to Teacher Background

- If you plan to hold a school science fair this week for students to practice their presentations and for parents and other students to see their work, see the helpful tips in the Stage 5 introduction.

#### Teacher Tasks Before the Session

- Ask adult volunteers to again come in to help students prepare presentations. You also may want to invite family members to do the same.

#### Tasks During the Session

- Let students practice their presentations for the first half of the meeting.
- During the second half, review with students what to expect on Fair day!
- You'll probably talk to two, three or even four judges. Between these talks there will be long times where no judge is with you. Sit patiently and wait. You can read or talk quietly to other students but be very, very careful not to disrupt judges conversing with students.
- Discuss logistics surrounding Fair Day: transportation, food, money, etc.

#### Teacher Tasks After the Session

- Add any assignments you want to remember.
- ★ **Final Details:** Remind those students who have not returned permission slips to do so as soon as possible. Phone calls to home might be necessary.
- ★ **Final Details:** Make sure students' file notes (abstract, design, etc.) have been assembled into project binders.

## Week 31

### Final Fair Preparations

**Overview** - Students finish any final project details and prepare to go to the affiliated Fair.

#### Teacher to Teacher Background

- This might be a hectic week. Students are finalizing their project display boards as you are finalizing preparations to go to the Fair. Students may need to meet with you or volunteers morning, noon and evening to get everything finished. It helps to be flexible and patient and to remember that this week will not last forever!

#### Teacher Tasks

- ★ **Final Details:** Go over the following with your students (and perhaps give them another informational handout):
  - time and location of departure for the trip;
  - appropriate dress for the day;
  - procedures for students who become lost;
  - food arrangements for the day;
  - housing arrangements if the affiliated Fair is in a distant city;
  - expected time and location of buses returning from the Fair;
  - students' arrangements for getting from school back to home.
- ★ **Final Details:** Be sure you have an emergency number for contacting your school or administrator.
- ★ **Final Details:** Be sure your school and administrator have your cell phone number.
- ★ **Final Details:** Make one final check on which students you expect to go to the Fair. Do you have permission slips for everyone going?
- ★ **Final Details:** Have in mind some "sponge activities" or fillers to occupy students if they must wait for activities or transportation on Fair day. (e.g., deck of cards, puzzles)

## Week 32

### The Fair!

**Overview** - The big day has finally arrived!

#### Teacher to Teacher Background

You probably haven't stopped to take a breath in the last three weeks! Congratulate your hard-working students and yourself. The fruits of everyone's labor are going to be realized this week! Enjoy!

#### Teacher Tasks Before Leaving for the Fair

Over the last several weeks, you have been tying up loose ends and ironing out the details surrounding the actual Fair Day. It's a good idea to run through this checklist to make sure you have remembered everything. (The week in which each of these tasks was first mentioned is given in parentheses.)

Ask yourself:

- Did all the student Intel® ISEF forms get to the SRC for final approval? (Week 25)
- Are chaperones arranged and confirmed? (Week 26 & 29)
- Are you and your students clear about the meeting point and departure time from the school? (Week 28)
- How are the student display boards getting to the Fair? (Week 27)
- Can you help the bus driver locate the Fair site? (Week 27)
- Do you know what part of the convention center to go to when you arrive at the Fair? (Week 27)
- Have you informed your students of the dress code for the day? (Week 28)
- Do students know what to do if they get lost? (Week 27)
- If needed, have arrangements been made for translators during judging interviews? (Week 27)
- Are food arrangements clear to you and the parents? (Week 27)
- What are the housing arrangements, if any, for the trip? (Week 27)
- Which students are actually going? (Week 31)
- Have those students turned in permission slips? (Week 31)
- Do you know how each student will get home after your return? (Week 28)
- Do you have an emergency number for your administrator or school? (Week 31)

- Will you have a working cell phone while on the trip? Do your school secretary and administrator have that cell phone number? (Week 31)
- Do you have any sponge/filler activities if they are needed on Fair Day? (Week 31)
- Add any other assignments you want to remember.
- 
- 
- 
- 

### Tasks During the Fair

- 
- 
- 
- 

### Teacher Tasks After the Fair

- REST!!
- Debrief and celebrate with students. Enthusiasm will run high for days, if not weeks. Now is the time to talk up going to the Affiliated Fair next year!
- How will student displays get back to your school?