

Intel Accelerates Supercomputing

Press Briefing
June 19, 2007

UNDER EMBARGO UNTIL 6/27

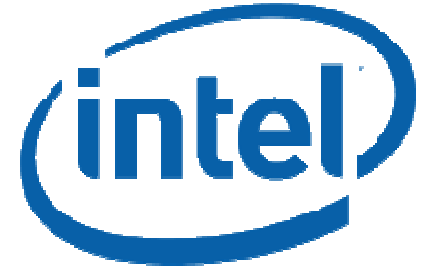

Today's Agenda

Intel® Connects Cables – 15 Minutes

Intel® Cluster Ready – 15 Minutes

Intel® Cluster Tools – 10 Minutes

**Press Briefing
June 19, 2007**

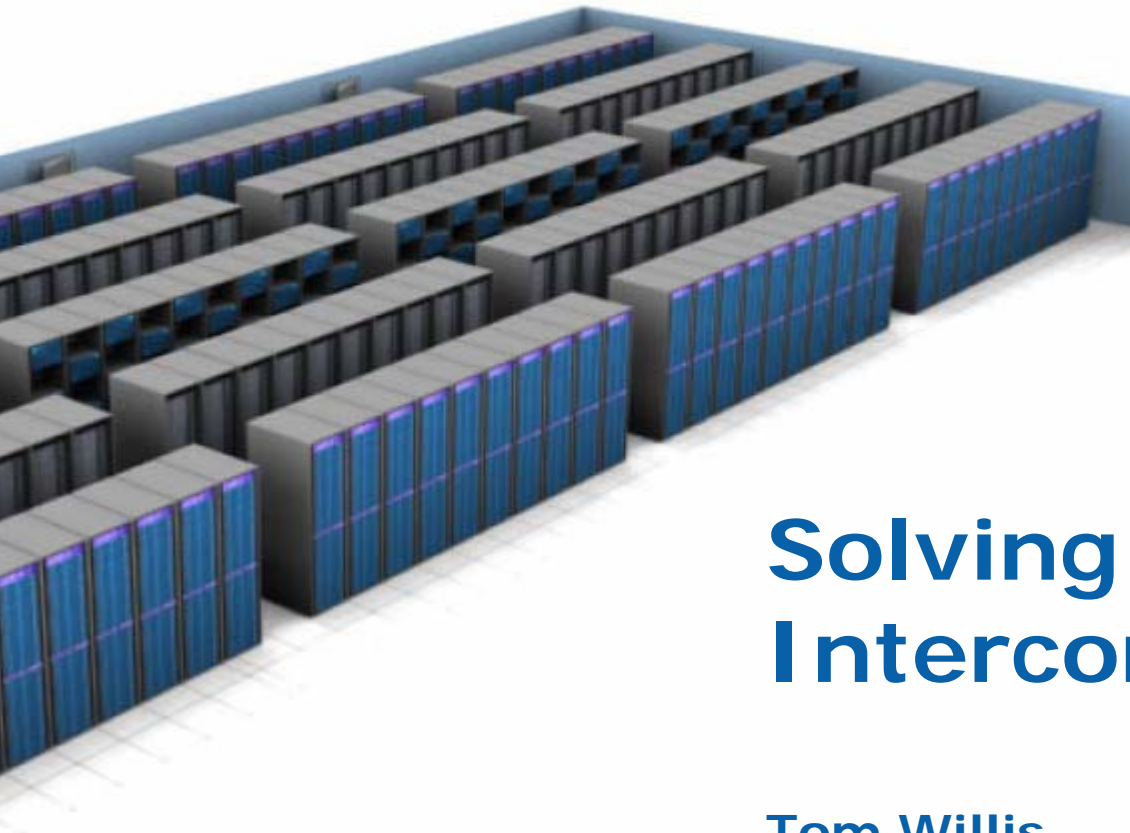
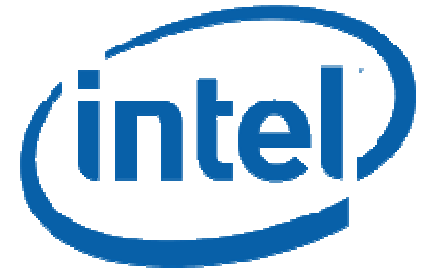

Solving the Cluster Interconnect Problem

Tom Willis

General manager, Intel® Connects Cables

The Cluster Interconnect Problem



24 AWG Copper Cables

- **Distance Limited @DDR:** 8-10 meters*
- **Heavy:** 1.2 Kg for a 10 meter cable
- **Bulky:** Blocks airflow, affects cooling

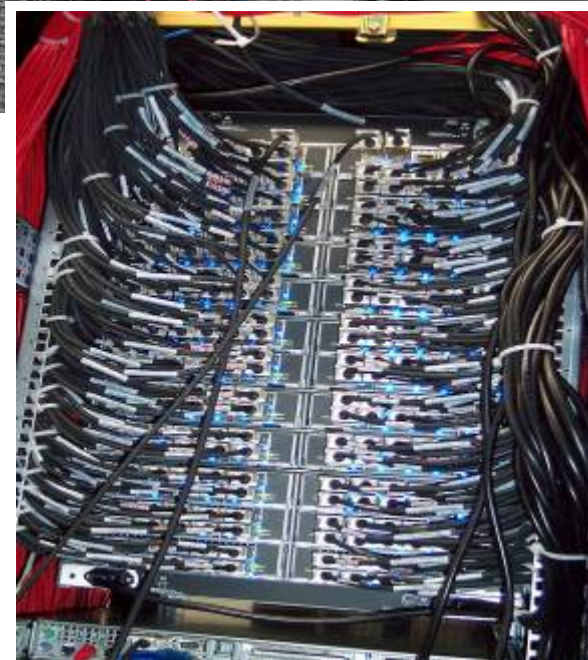

Copper cables limit HPC cluster design

*Depends on Bit Error Rate requirement



Introducing Intel® Connects Cables

High-performance 20 Gbps Optical Cables



Intel® Connects Cables

What Are They ?

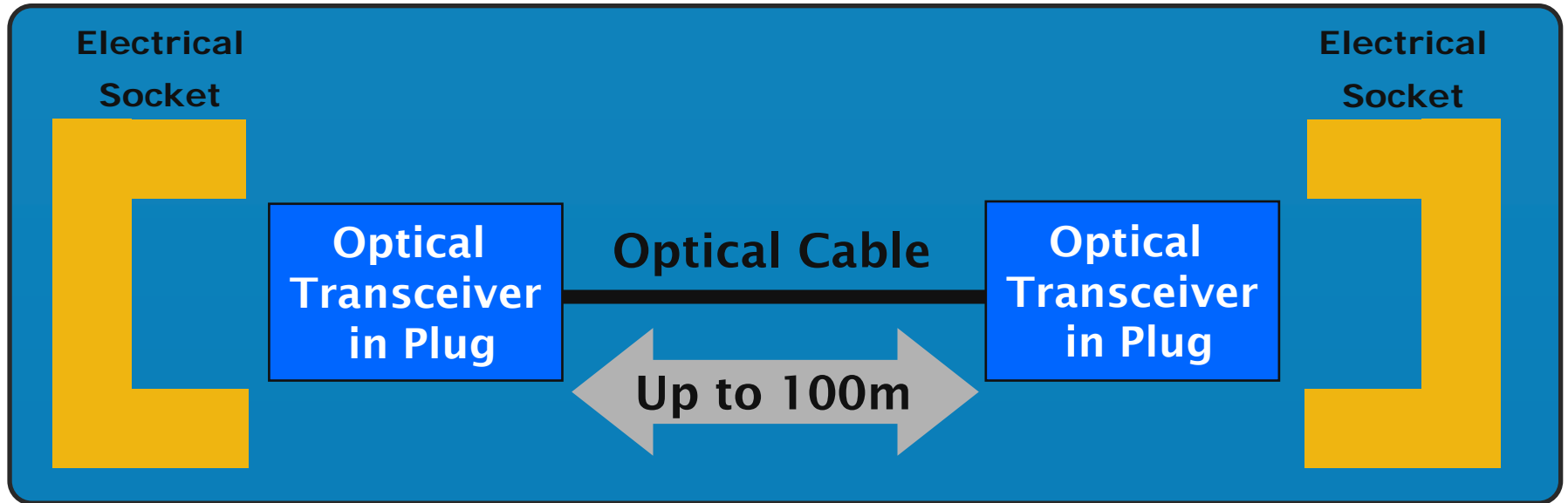

A Drop In Replacement for Copper Cables

- **Compatible:** Use existing copper sockets
- **Reliable:** No user accessible optical interface
- **Low Cost:** No separate optical transceivers

*Source: Intel internal testing

Intel® Connects Cables

High-Performance 20 Gbps Optical Cables



Enable Large Cluster Scale Out

- High data rate: 20 Gbps per cable*
- Long distance: Up to 100 meters
- Low bit error rate: 10^{-15} BER
- Low conversion latency: 550 picoseconds**

Reduced Installation, Maintenance

- Less weight: 84% lighter
- Less volume, better airflow: 83% smaller
- Smaller bend radius: 40% less
- Low Electro Magnetic Interference
- No ground loops



*Source: All claims based on Intel Internal testing

**Per pair of connectors



Longer: 100m for Cluster Scaling



- Build larger clusters with 20 Gbps DDR
- Design clusters based on needs not on cable lengths

- Locate and consolidate CPUs, switches and storage
- Improve airflow
- Simplify cluster installation and maintenance

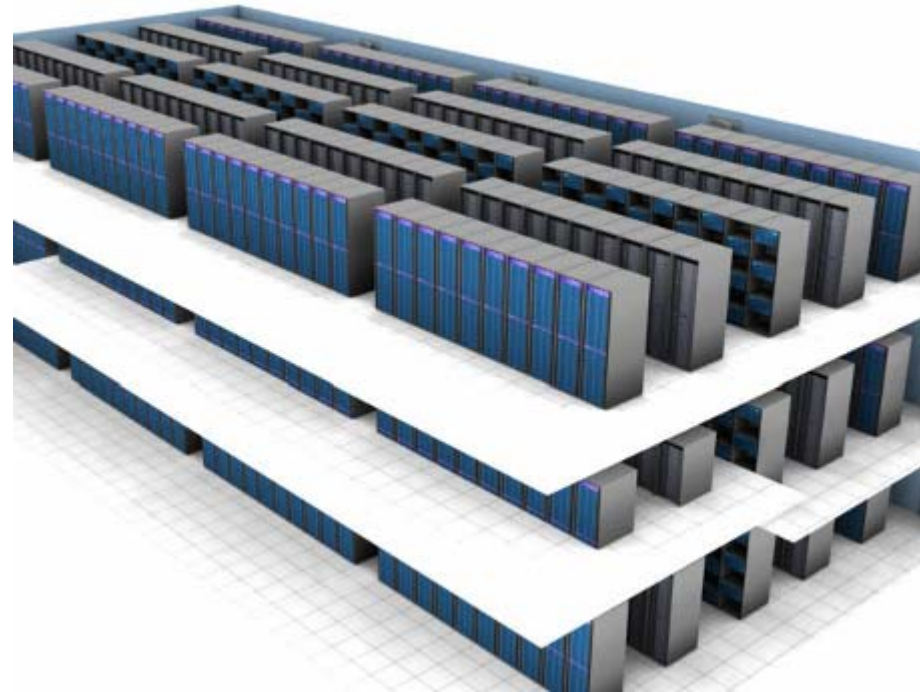

*10X longer than 24 AWG copper cables***

*Fat Tree Architecture

**for double data rates

Lighter: The 10 Meter Challenge

Intel® Connects Cable

24 AWG Copper Cable



.18 Kg

1.135
Kg

- Less weight to bend pins on servers
- No need to reinforce floors and cable ladders

*84 % lighter than 24 AWG copper cables**

*Source: Intel internal testing

Intel® Connects Cables

Thinner: Better Airflow in Racks, Floors

Volume Comparison of 10 m Cables*

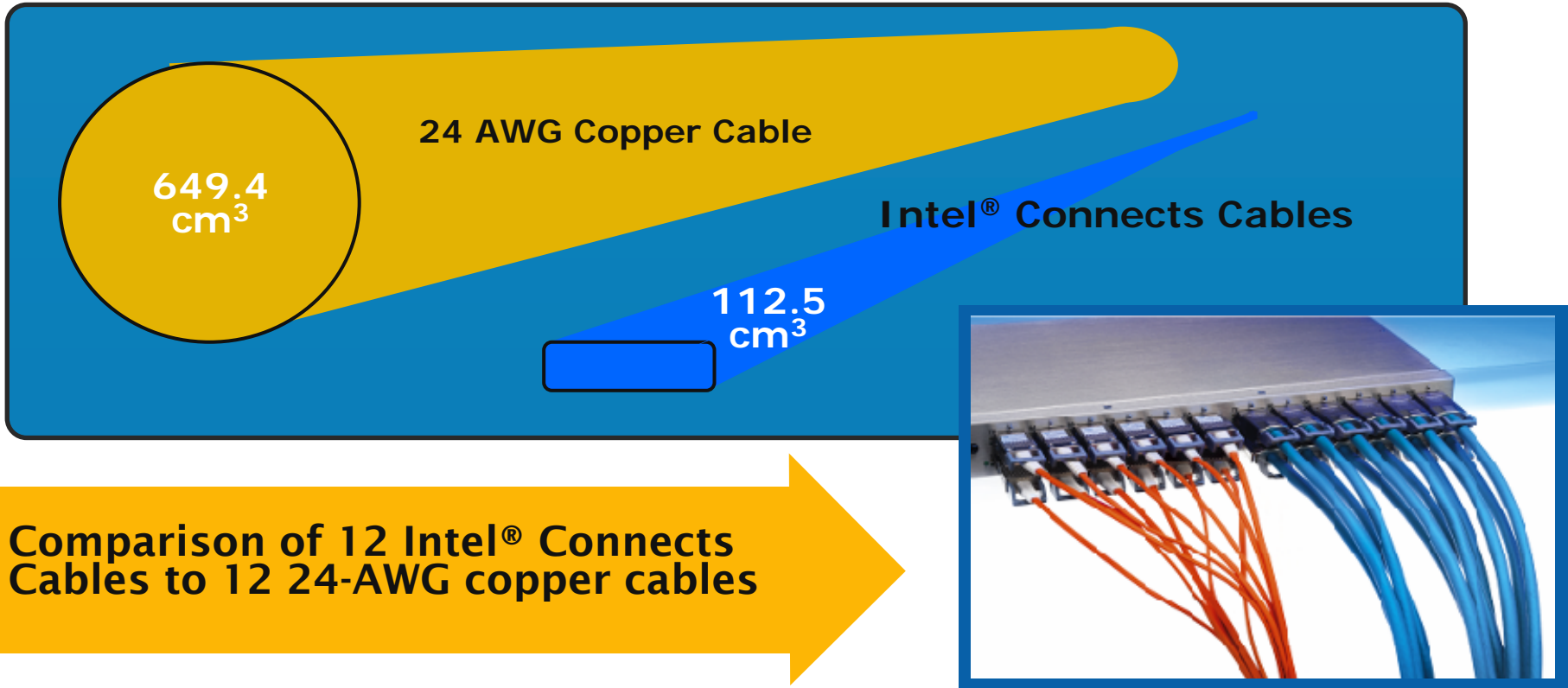

Comparison of 12 Intel® Connects Cables to 12 24-AWG copper cables

*83% smaller than 24 AWG copper cables***

*Does not include connectors

**Source: Intel internal testing



Intel® Connects Cables

More Flexible: Easier Install, Maintenance

“Cable Assembly Bend Radius**”

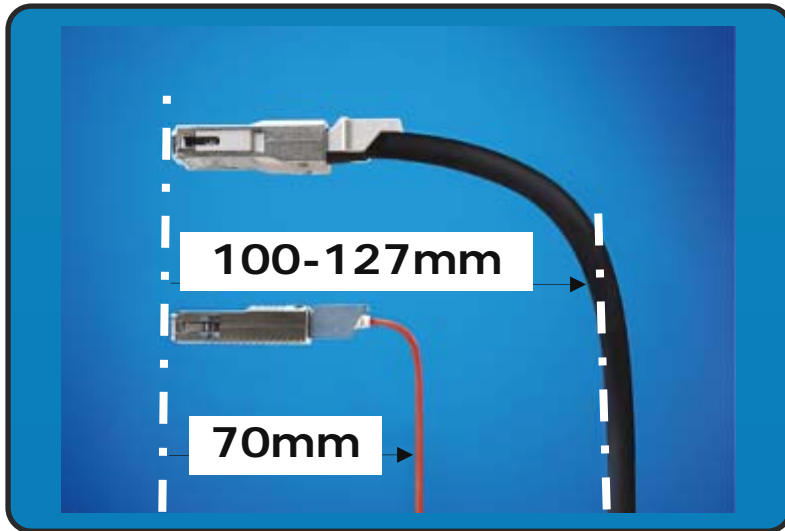

Smaller Connectors**

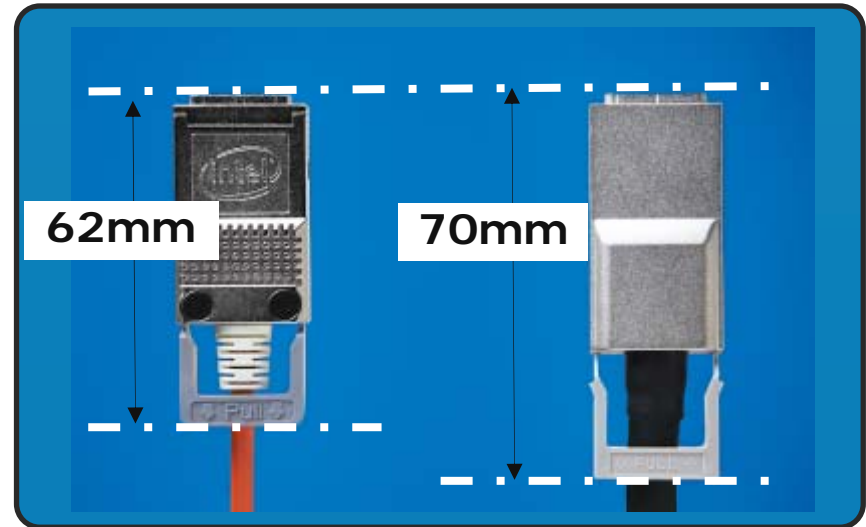

- Tighter bending cable
- Shorter connectors
- More flexible cable

40% smaller “Cable Assembly Bend Radius”

*Source: Intel internal testing. Note: The cable assembly bend radius is measured in a direction perpendicular to the plane defined by the bail, and in a direction away from the bail.

**Connectors in closed position

Intel® Connects Cables

More Reliable: 10^{-15} Bit Error Rate*

Bit Error Rate at 20 Gbps per link

	10^{-12} BER @20Gbps	10^{-15} BER @20Gbps
Errors Per Day for a single link	1728	1.7
Errors Per Day For 1000 links	1,728,000	1,728

10^{-12} interconnects
BER/day for 1000 links

Intel® Connects Cable
BER/day for 1000 links

1000 times less BER than interconnects at 10^{-12}

*Source: Tektronix Lab Evaluation

Intel® Connects Cables Actual Bit Error Rates May Even Be Lower*

10 Meter Intel® Connects Cable** 100 Meter Intel® Connects Cable**

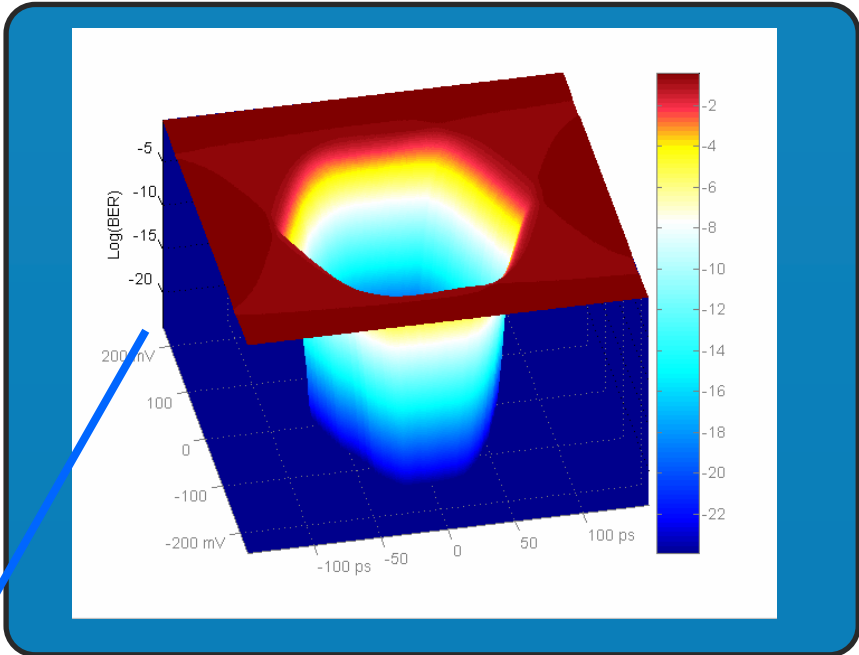
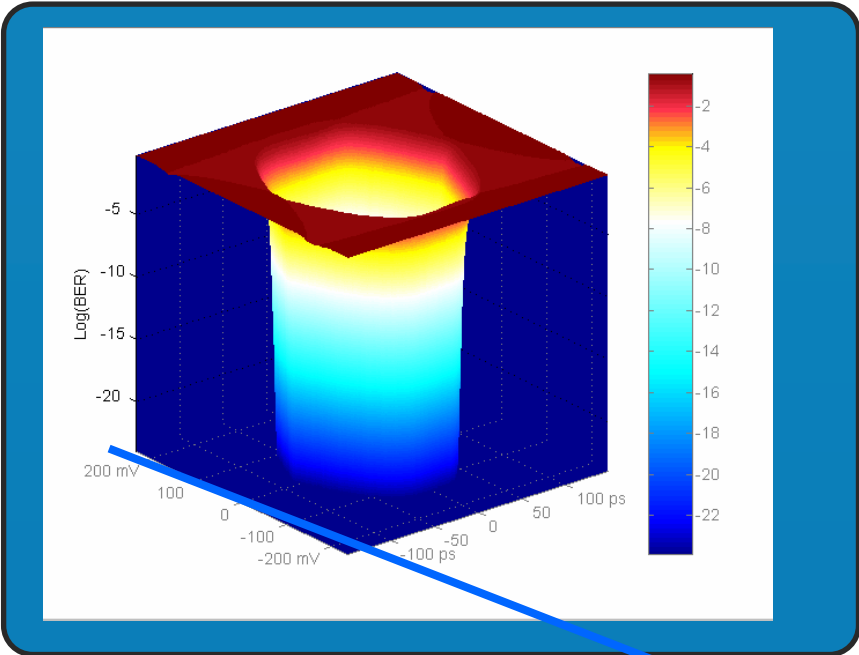

10⁻²⁵

Extremely low BER for high HPC compute fabric stability

*Note: Specified BER for Intel® Connects Cables is 10⁻¹⁵

**Source: Tektronix Lab Evaluation



Intel® Connects Cables

Better Quality: At 10m .. at 100m

1 Meter
Intel®
Connects
Cable

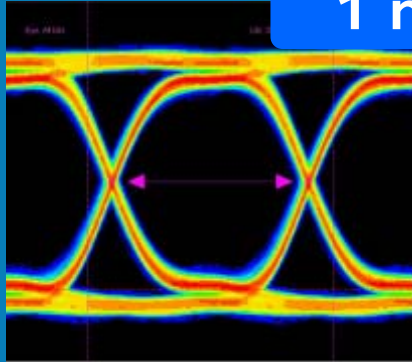

100 Meter
Intel®
Connects
Cable

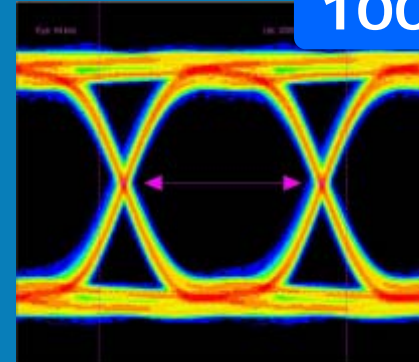

10 Meter
Intel®
Connects
Cable

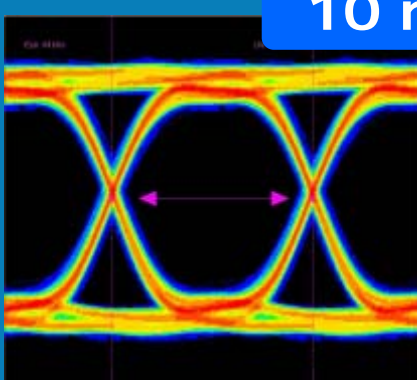

5 Meter
24 AWG
Copper
Cable

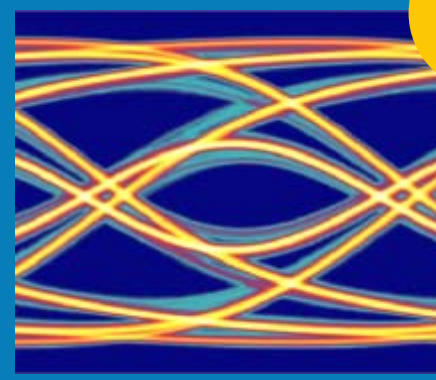

Superior signal quality from 1 to 100 meters

Intel® Connects Cables

Participation in the ISC '07 Network

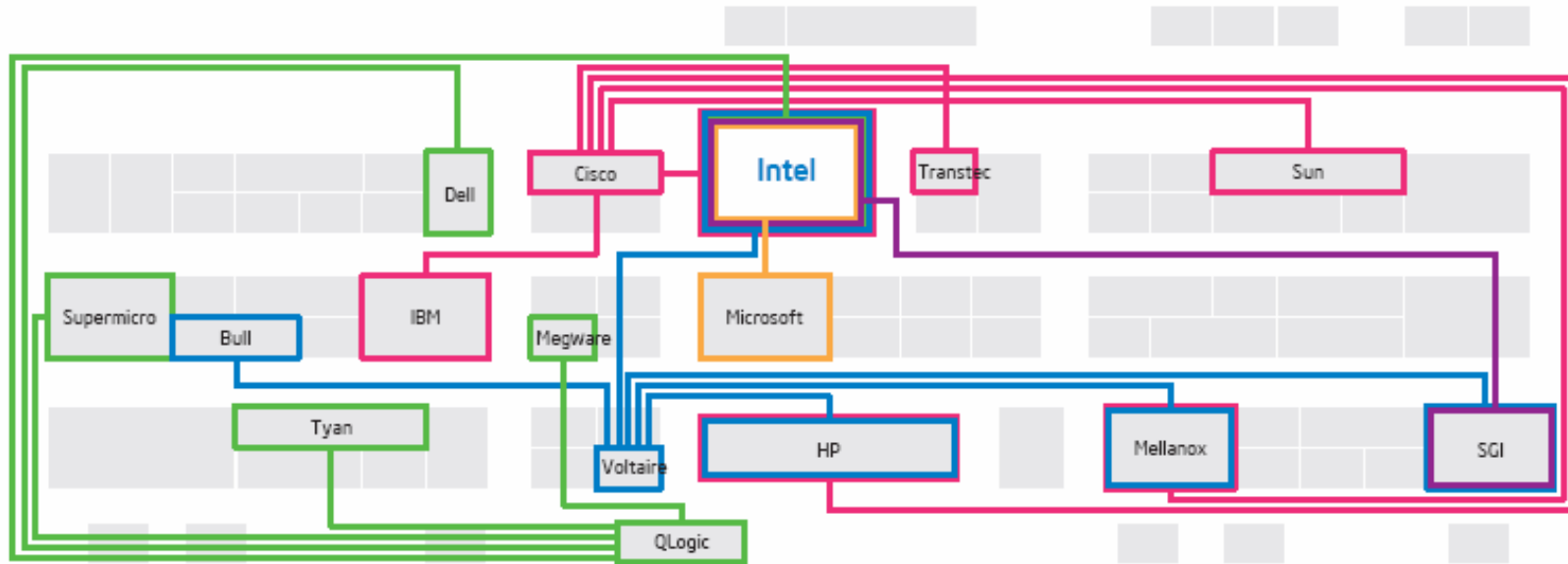

Key

- Cisco Fabric
- Voltaire Fabric
- QLogic Fabric
- Microsoft Demo
- SGI Demo

Be sure to visit the Intel booth for live tests of Intel Connects Cable performed by Tektronix. Ciara Technologies HPC systems will also be demonstrated at the Intel booth.

Copyright © 2007 Intel Corporation. All rights reserved. Intel and the Intel logo are trademarks of Intel Corporation in the U.S. and other countries. Other names and brands may be claimed as the property of others.



20 Gbps at 100 meters across the ISC '07 show floor

Intel® Connects Cables

ISC '07 Network Participation*



*Other names and brands may be claimed as the property of others.



Intel® Connects Cables Availability



- **Launch:** 6/27 at ISC '07, Dresden, GR
- **Production Release:** 2nd Half '07
- **Pricing:** Comparable to 24 AWG copper
- **Distributors:**



A coiled red optical fiber cable is shown against a blue background. The cable is thick and flexible, with a silver metal connector at the end. The connector has the Intel logo on it and a small label that reads "2.5/125 OPTICAL FIBER". The cable is coiled in a large loop, and the connector is positioned in the center of the loop. The background is a solid blue color.

Intel® Connects Cables
Longer, Lighter, Thinner, More Reliable

For more information visit...
*www.intelconnects.com**

*Site will be live on 6/27



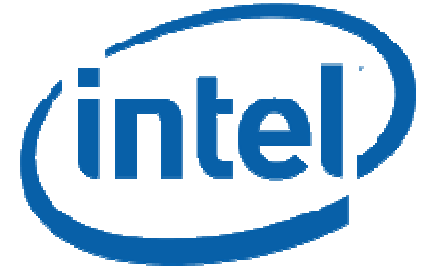

Intel® Cluster Ready Overview Intel WW HPC – Volume

**Dr. Herbert Cornelius
Director of the Intel Advanced Computing Center**

Press / Analyst Briefings

Agenda

- What are we targeting and why?
 - High Performance Computing (HPC) Volume Marketplace
- What is Intel Cluster Ready?
- Summary

HPC Market Dynamics*

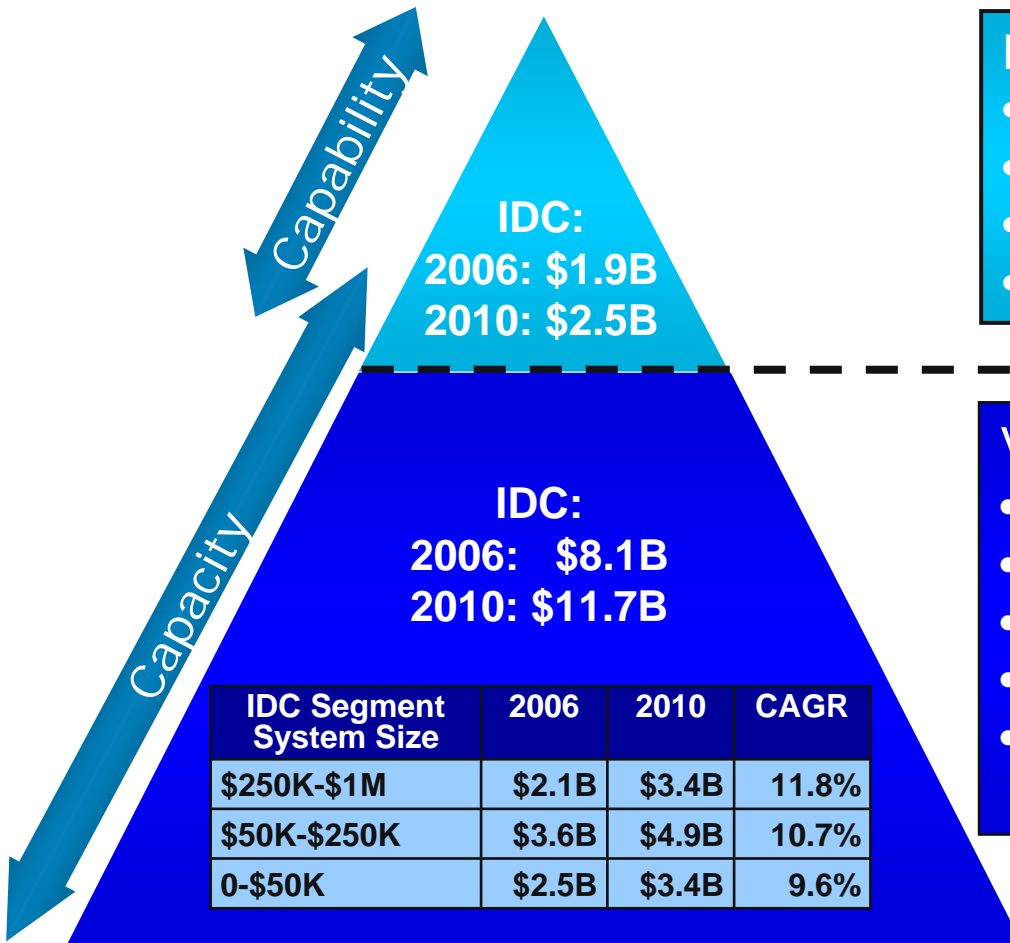

High End (>\$1M system)

- Maps to “Top 150”
- Mainly capability & constellations
- Risk takers, early adopters
- Almost all custom SW (HW too)

Volume

- Mainly capacity, <250 nodes
- Clusters >50% of revenue & growing
- Custom and ISV apps
- Ease of use valued
- Rapid growth driven by broader commercial HPC usage

IDC Segment System Size	2006	2010	CAGR
\$250K-\$1M	\$2.1B	\$3.4B	11.8%
\$50K-\$250K	\$3.6B	\$4.9B	10.7%
0-\$50K	\$2.5B	\$3.4B	9.6%

Total segment > \$10.0B in 2006
Forecast > \$14.2B in 2010

Intel Cluster Ready will Focus on the Fast Growing Volume Segment

* All data from IDC Worldwide Technical Computing Systems Revenue 2006-2010 #201733 May 2006.

HPC MSS: Growth In Clusters

Cluster Market Penetration

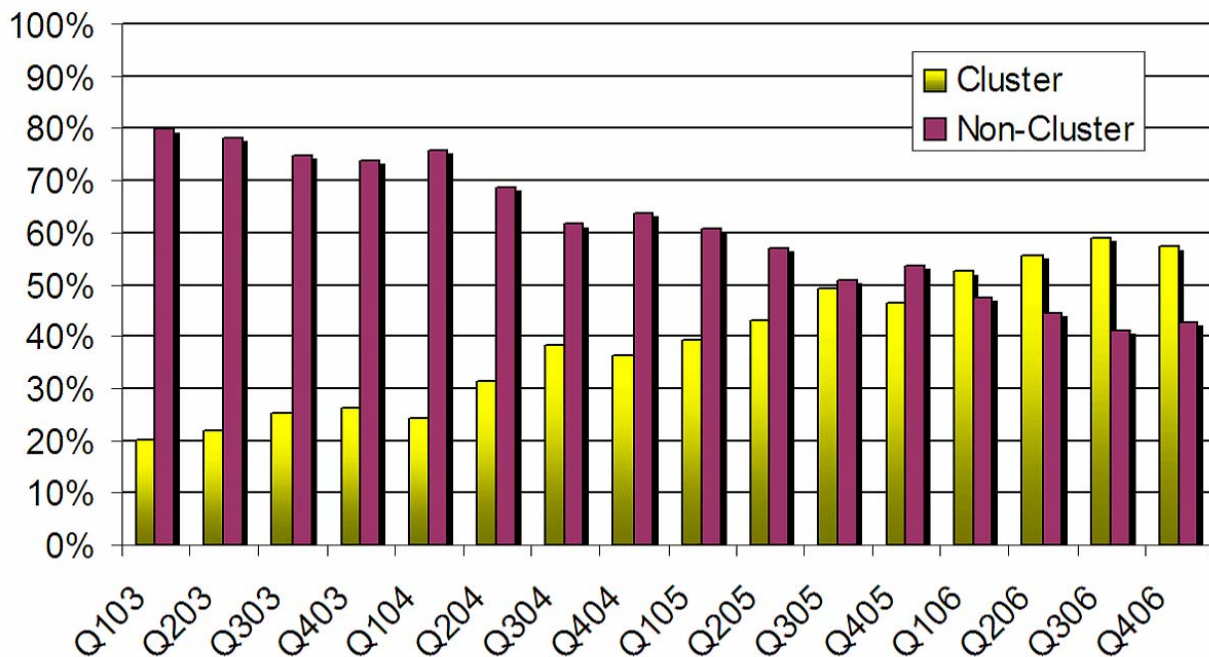

Clusters @ 2010
\$11b HPC revenue
75-85% of total HPC revenue

- **NOTE:** Per IDC Program Vice President – HPC, Earl Joseph @ IDC’s annual analyst briefing @ ISC 2006
- Predicted cluster growth would continue at CAGR of 13% through 2010
- Reaching \$11b in 2010 ...of total HPC systems revenue @ \$14b in 2010
- From 2010, Cluster system revenues settling out over time to 75% to 85% of total HPTC market revenue

What Do Most HPC Buyers Really Want?

To get their job done

- Complete their task using HPC applications
e.g. Modeling products, fluid flow, chemical analysis, etc.
- Hardware specifics do not matter but ...
 - ✓ *must "just work" [very positive out of box experience]*
 - ✓ *must be cost effective*
 - ✓ *must scale*

SMP Solutions

- Get Job Done
- Limited in Scale
- Expensive

Cluster Solutions

- Cost Effective
- Scale Well
- Harder to Deploy and Use

A cluster with characteristics of an Enterprise server

- Turn it on, it works
- Does not need dedicated staff to keep it running

Our response is called Intel® Cluster Ready



Cluster Solutions Platform Vision

Proposed Solution

- Comprehensive specification
- Develop series of recipes, for each Intel HPC node platform
- Validation & Certification tools and program for “Intel Cluster Ready” platforms
- ISV validates and release apps for “Intel Cluster Ready” systems
- ➔ **The ISV will know that their code will work on the “Intel Cluster Ready” platforms and the HW System Players will know that the “Intel Cluster Ready” ISV codes will run on their platform.**

Process

- Knowledge of experienced cluster architects
- Inputs of our strategic partners
- Defines a baseline system and allows the ecosystem to promote their value add

Products

- New: the Cluster Validation Tool (“Intel Cluster Checker”)
 - ✓ Verify that the cluster was built according to the specification
 - ✓ Verify that the cluster is operational before the ISV code is loaded
 - ✓ Verify that delivered cluster is materially identical to Certified Cluster
 - ✓ Post deployment, utilized by OEM/Channel, ISVs, Buyers as fault isolation tool

Results

- Faster cluster deployment
- Reduce staffing requirements
- Greater reliability



Intel® Cluster Ready is...

A Program to make it easier for end users to buy, deploy and use clusters.

- Backed by reference implementations on Intel server platforms
- Including tools to confirm compliance

A three-way collaboration between ISVs, OEMs/Channels, and Intel

- HW System Players solutions certified as compliant with the specification
 - Specification encourages HW Systems Players to add “Secret Sauce”
 - ✓ Process facilitating HW Systems Players easily define compliant recipes
- ISVs applications registered as compliant with the specification
 - Registered applications will run out-of-the box
 - ✓ ...on any compliant Intel Ready Cluster
- Buyers will be requesting Intel Cluster Ready solutions

More than a Cluster Solution Specification



Intel® Cluster Ready

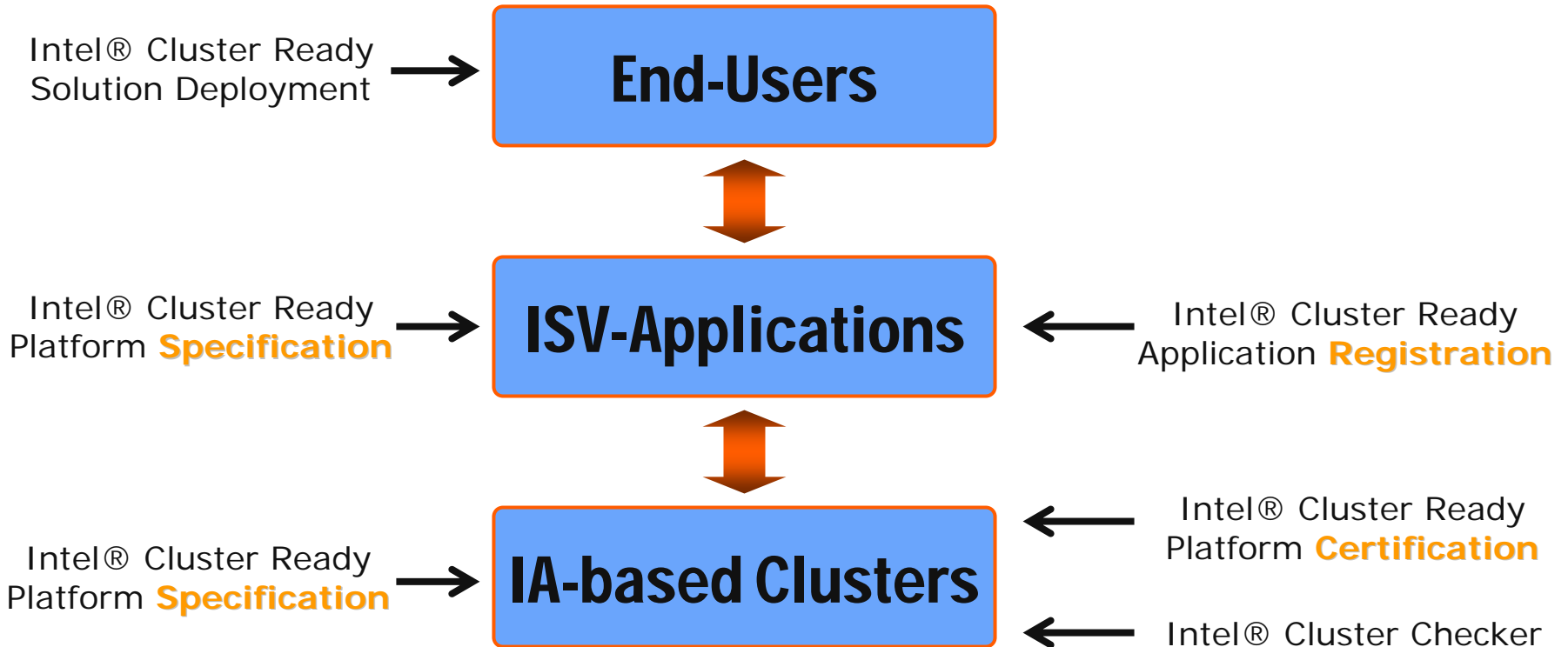

Intel Cluster Ready - Abstract

Who does what?

Intel

1. Publishes cluster specification
2. Makes reference cluster available to ISVs for testing & verification
3. Makes reference recipes available to HW System Providers
4. Provide "Intel Cluster Checker" tool to help HW System Providers verify systems for specification compliance

HW System Providers

1. Design & build systems to meet Intel Cluster Ready specification
2. Use Intel Cluster Checker to "certify" system configuration is compliant to the specification
3. "Certified" cluster configuration becomes a repeatable recipe
4. OEM/VAR & Channel Partners use recipes to build compliant clusters

ISVs

1. Write applications stack to the Intel Cluster Ready specification
2. Test applications against reference clusters
3. "Register" their application software

Testimonials

"**Dell** has always been focused on delivering standards-based HPC solutions to meet customers' needs as the industry has moved away from high-cost, proprietary systems," said **Kevin Noreen, Senior Product Marketing Manager, Dell Product Group**. "We're taking the next logical step by working with industry leaders such as Intel and Platform to deliver Cluster Ready solutions that will drive simplification and reduce the complexity associated with HPC solution deployments."

"...with the introduction of the Intel® Cluster Ready program, **Platform's** collaboration with Intel over the past several years delivers a standardized recipe for the next generation of servers," said **Songnian Zhou, CEO of Platform Computing**

"**ANSYS, Inc.**, a global innovator of simulation software and technologies designed to optimize product development processes, is excited to be a charter member of the Intel Cluster Ready Program. High performance clusters are a key technology for our customers, and we expect that the Intel Cluster Ready program will make it easier for ANSYS software to deploy seamlessly on cluster systems from a variety of our OEM partners. This will benefit our customers, who should be able to implement a combined hardware and software solution faster and with less risk and cost," said **Chris Reid, VP Marketing, ANSYS, Inc.**

"**LSTC** is confident that Intel's newly announced Intel® Cluster Ready program will be welcomed by LS-DYNA worldwide users. Our MPP customers and their IT support staffs will no longer be required to expend resources bringing their clusters online. Set-up and configuration time will be significantly decreased or eliminated entirely as a result of Intel's certification solution," said **John O. Hallquist, President & Founder, LSTC**

"Intel Cluster Ready recipes give customers yet another great reason to deploy **SGI** Altix XE clusters. Because Intel Cluster Ready makes it easier for ISVs to run their optimized software on the Altix XE platform, customers can rapidly and cost-effectively implement industry-specific solutions that meet the demanding requirements of high-performance computing," said **Bill Mannel, Senior Director, SGI Server Marketing**.

*Other names and brands may be claimed as the property of others.



Partners – Intel Cluster Ready Community



*Other names and brands may be claimed as the property of others.



Intel Cluster Ready - Summary

- **Easier for end-users to deploy Intel based clusters**
- **More efficient for HW vendors to build Intel based clusters**
- **Easier for ISV's to develop Cluster applications on Intel architecture**
- **What is the "Intel Cluster Solutions Platform"**
 - Comprehensive specification of a core cluster platform architecture
 - TTM cluster integration and testing for each relevant node platform
 - Reference systems, with recipes, to enable OEMs and channel
 - Intel® Cluster Checker tool to validate clusters
 - 'Certification' of OEM & Channel HPC cluster systems as "Intel® Cluster Ready"
 - 'Registration' of HPC ISV applications as "Intel® Cluster Ready"

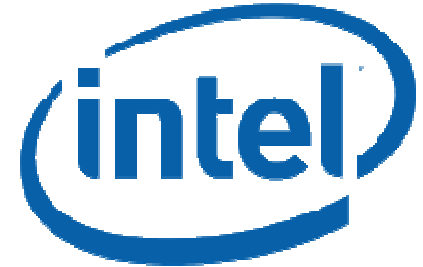

Intel Cluster Tools

Dr. Herbert Cornelius
Director of the Intel Advanced Computing Center

Press / Analyst Briefings

Cluster Software & Technologies
Enterprise Solutions Software
Division

Intel Cluster Ready and Intel Software Tools

Intel Cluster Ready:

- Intel's new program to make building, deploying, using cluster easier

Intel Software Tools:

- Support developers, to create, optimize, and scale out parallel applications
 - Multi-threading (Intel Threading tools)
 - Clustering (Intel Cluster tools)

Combined: Intel Software tools are part of Intel Cluster Ready systems

- Validated run-time versions are available on every system, to ensure consistency
- For developers: Intel Cluster tools ensure application portability, performance, and scalability on Intel Cluster Ready systems



Intel Software Tools

...for all phases in Software Development

Visualization and insight

Architectural Analysis

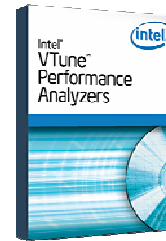

Scalable solutions

Introduce Parallelism



Latent Error Detection

Confidence / Correctness



Optimize for parallelism

Optimize / Tune

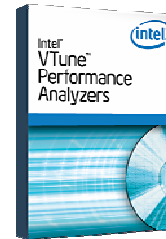

Intel Trace Analyzer 7.0 Features

- User can quickly focus at the appropriate level of detail to find performance hotspots and bottlenecks
- Use of hierarchical displays to address scalability in time and processor–space
- High–performance graphics, excellent zooming and filtering
- MPI Checking - correctness checking library

New

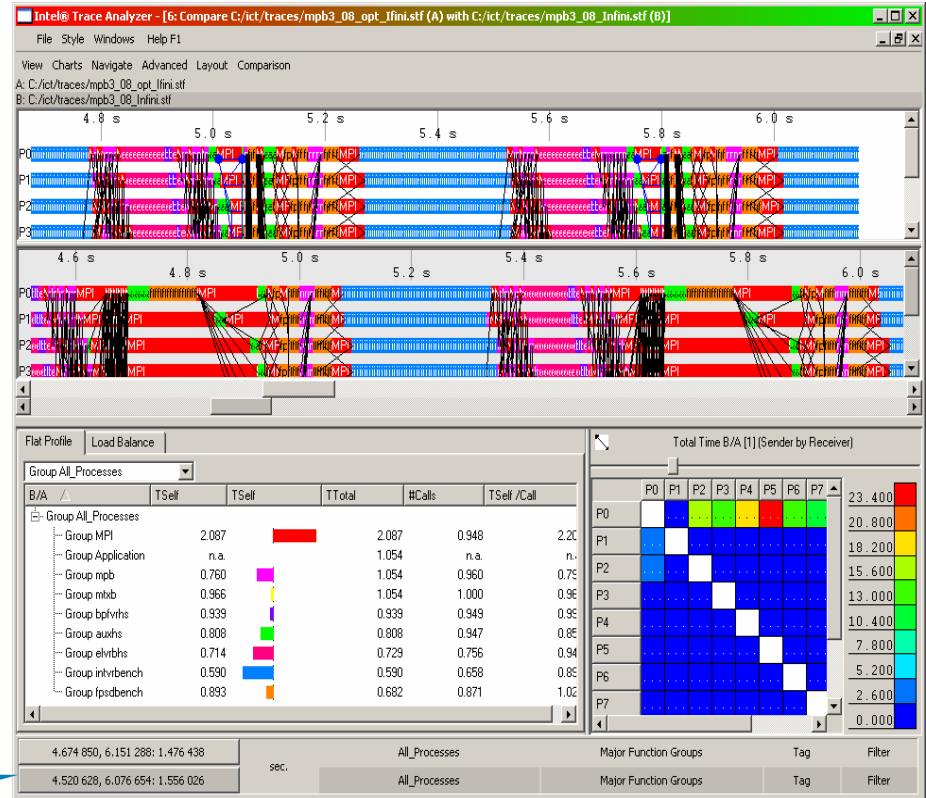

Intel® MPI Library

A simple solution for the use and development of applications running on different networks

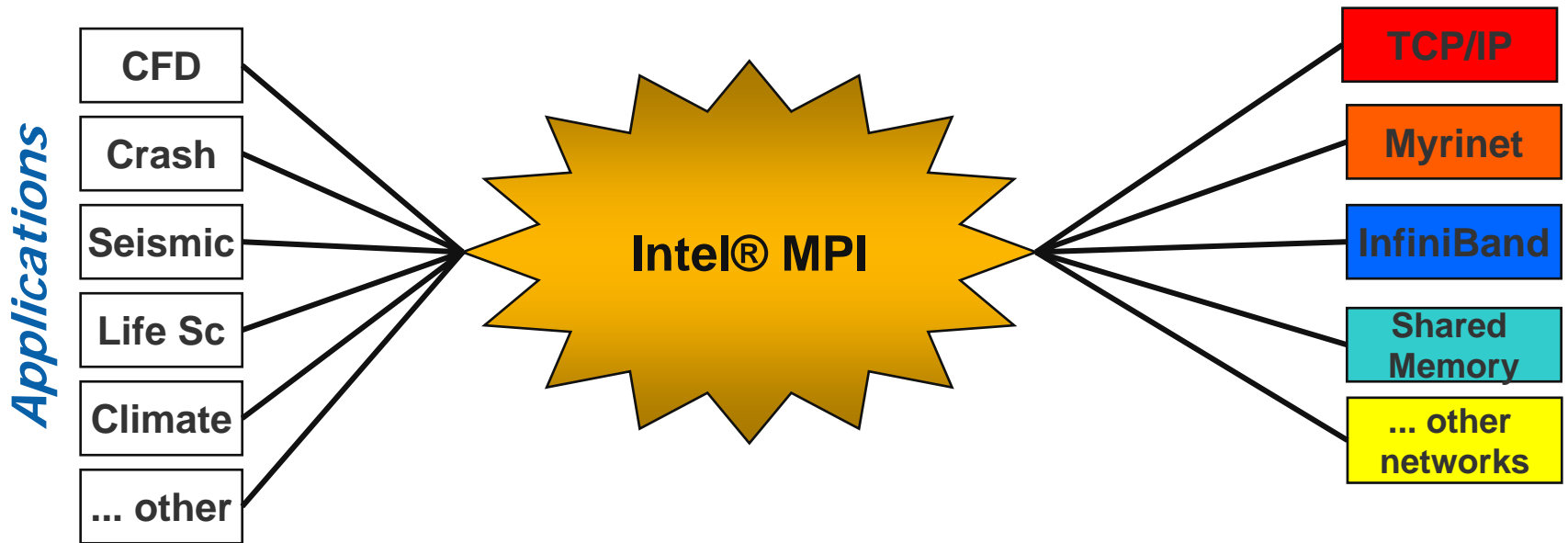

Develop applications on a single interconnect

Run applications on a chosen interconnect

Intel MPI Advantage

Portability

Cluster applications executables run on any interconnect

→ greatly reduced effort for development, testing, and validation

Performance

Optimized algorithms for collective operations

→ leading performance demonstrated in many industry benchmarks

Productivity

Unique toolkit for error checking and performance tuning

→ faster time to achieve robust and optimized applications

Used and supported by many ISVs: LSTC-Dyna, Fluent, MSC.MARC,
ESI PAM-CRASH, STAR-CD, ...

Cluster OpenMP

Runs (slightly modified) OpenMP codes on a commodity cluster

- No need to rewrite the code it in MPI
- Exploit existing OpenMP codes which run on SMP machines on cheaper clusters
- Supports C, C++ and Fortran

Suitable applications

- scale successfully with OpenMP on SMP
- have good data locality
- use synchronization sparingly

What's new at ISC'07?

Technical Preview of Intel Cluster Toolkit 3.1

- Start beta evaluation with HPC community
- Release planned for Q4/2007

Intel Software Tools are OS independent

- Traditionally leading on Linux clusters
- Intel Cluster Toolkit 3.1 supports Linux and Windows

A blue starburst graphic with the word "New" in white text inside it.

New

New product bundles

- All necessary developer tools in one bundle: compilers, libraries, and cluster tools

More information: www.intel.com/software



