

# Intel® Server System H2000JF & H2000WP Quick Installation User's Guide

Thank you for buying an Intel® Server System. The following information will help you assemble your Intel® Server System and install components.

If you are not familiar with ESD [Electrostatic Discharge] procedures used during system integration, see the complete ESD procedures described in your Service Guide.

This guide and other supporting documents are located on the web at:  
<http://www.intel.com/support>.

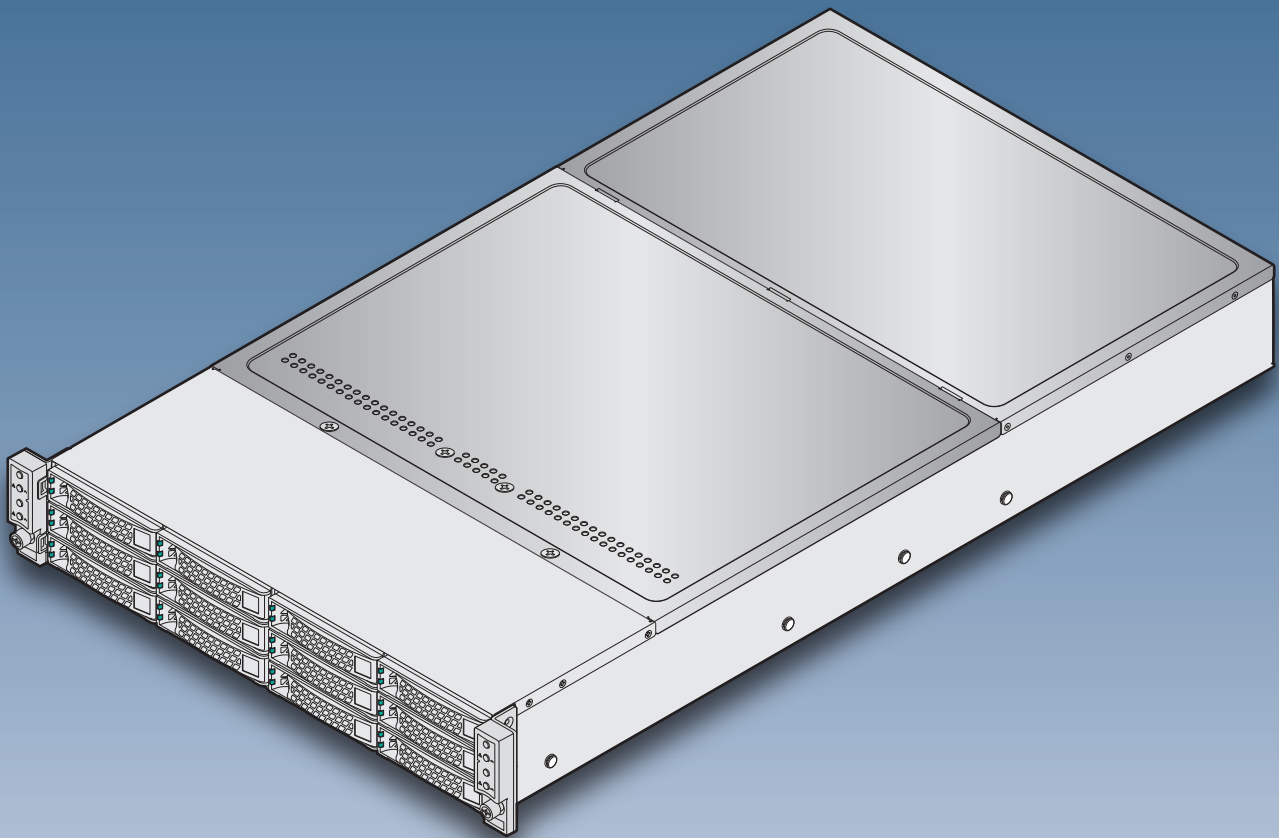

\* 12 x 3.5" hard drive bay system as shown

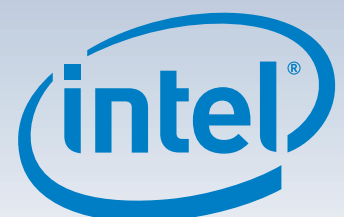

G54451-002

( This page is intentionally left blank. )

# Table of Contents

System Overview (Intel® Server System H2000JF Family).....	1
System Overview (Intel® Server System H2000WP Family) .....	2
General Installation Process .....	3
Preparing the System .....	3
Install/Remove the Power Supply Unit .....	3
Install/Remove Computer Node Tray .....	3
Install/Remove Node Tray Air Duct .....	4
Remove Processor Heat Sink(s) .....	4
Install the Processor(s) .....	5
Install Processor Heat Sink(s) .....	6
Install Memory Modules .....	6
Install/Remove the Front Bezel .....	7
Install Hard Drives .....	7
Installing PCI Riser Assembly and Add-in Card on Riser Slot 1 .....	8
Install I/O Module Riser and Carrier Assembly on Riser Slot 2 .....	9
Install Intel® RAID C600 Upgrade Key (optional) .....	9
Install Intel® Remote Management Module 4 (optional) .....	9
Remove the Top Cover .....	10
Install Top Cover .....	10
Software .....	10
Assembling the Server System with Server Chassis H2000 .....	11
Removing a Node Tray from a Chassis .....	11
Reference .....	12
Intel® Server Board S2600JF Component Layout.....	12
Intel® Server Board S2600WP Component Layout .....	12
Front Panel Controls and Indicators .....	13
Cable Routing inside Server System H2000JF Node Tray .....	13
Optional Accessories .....	13
Cable Routing inside Server System H2000WP Node Tray .....	14
Optional Accessories .....	14
Intel® Server System RAID Options .....	14
Intel® Server System RAID Options .....	15

## Warning



Read all caution and safety statements in this document before performing any of the instructions. Also see the *Intel® Server Board and Server Chassis Safety Information* document at: <http://www.intel.com/support/motherboards/server/sb/cs-010770.htm> for complete safety information.

## Warning



Installation and service of this product to be performed only by qualified service personnel to avoid risk of injury from electrical shock or energy hazard.

## Caution



Observe normal ESD [Electrostatic Discharge] procedures during system integration to avoid possible damage to server board and/or other components.

## Tools Required

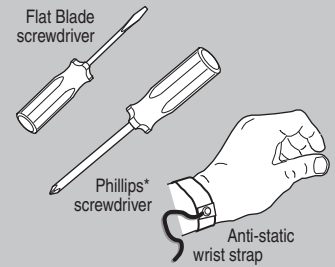

Intel is a registered trademark of Intel Corporation or its subsidiaries in the United States and other countries. \*Other names and brands may be claimed as the property of others. Copyright © 2012, Intel Corporation. All rights reserved.

## Thermal Operation and Configuration Requirements for Server System H2000WP

To keep the system operating within supported maximum thermal limits, the system must meet the following operating and configuration guidelines:

- Ambient in-let temperature cannot exceed 35° C and should not remain at this maximum level for long periods of time. Doing so may affect long term reliability of the system.
- The CPU-1 processor + CPU heatsink must be installed first. The CPU-2 heatsink must be installed at all times, with or without a processor installed.
- **Memory Slot population requirements:**  
NOTE: Specified memory slots either can be populated with a DIMM or supplied DIMM Blank. Memory population rules apply when installing DIMMs.
  - **DIMM Population Rules on CPU-1**  
Install DIMMs in order: channels A1, B1, C1, D1, A2, B2, C2, and D2. Remove only DIMM blanks when populating the slot with a DIMM.
  - **DIMM Population on CPU-2**  
Install DIMMs in order: Channels E1, F1, G1, H1, E2, F2, G2, and H2. Only remove DIMM blanks when populating the slot with a DIMM.
- All hard drive bays must be populated. Hard drive carriers either can be populated with a hard drive or supplied drive blank.
- The air duct must be installed at all times.
- The empty power supply bay must have the supplied filler blank installed at all times.
- The system top-cover must be installed at all times. Remove the top cover only when the system is in power-off state.



## Warning



Read all caution and safety statements in this document before performing any of the instructions. Also see the *Intel® Server Board and Server Chassis Safety Information* document at: <http://www.intel.com/support/motherboards/server/sb/cs-010770.htm> for complete safety information.

## Warning



Installation and service of this product to be performed only by qualified service personnel to avoid risk of injury from electrical shock or energy hazard.

## Caution



Observe normal ESD [Electrostatic Discharge] procedures during system integration to avoid possible damage to server board and/or other components.

## Tools Required

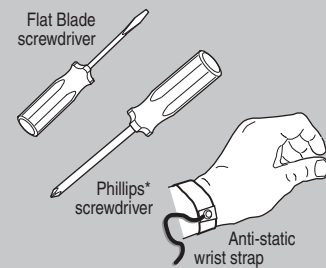

Intel is a registered trademark of Intel Corporation or its subsidiaries in the United States and other countries. \*Other names and brands may be claimed as the property of others. Copyright © 2012, Intel Corporation. All rights reserved.

## Thermal Operation and Configuration Requirements for Server System H2000JF

To keep the system operating within supported maximum thermal limits, the system must meet the following operating and configuration guidelines:

- Ambient in-let temperature cannot exceed 35° C and should not remain at this maximum level for long periods of time. Doing so may affect long term reliability of the system.
- The CPU-1 processor + CPU heatsink must be installed first. The CPU-2 heatsink must be installed at all times, with or without a processor installed.
- **Memory Slot population requirements:**  
NOTE: Specified memory slots either can be populated with a DIMM or supplied DIMM Blank. Memory population rules apply when installing DIMMs.
  - **DIMM Population Rules on CPU-1**  
Install DIMMs in order; Channels A, B, C, and D. Only remove DIMM blanks when populating the slot with a DIMM.
  - **DIMM Population on CPU-2**  
Install DIMMs in order; Channels E, F, G, and H. Only remove DIMM blanks when populating the slot with a DIMM.
- All hard drive bays must be populated. Hard drive carriers either can be populated with a hard drive or supplied drive blank.
- The air duct must be installed at all times.
- The empty power supply bay must have the supplied filler blank installed at all times.
- The system top-cover must be installed at all times. Remove the top cover only when the system is in power-off state.

# System Overview

## Intel® Server System H2000JF Family

### System Features and Components

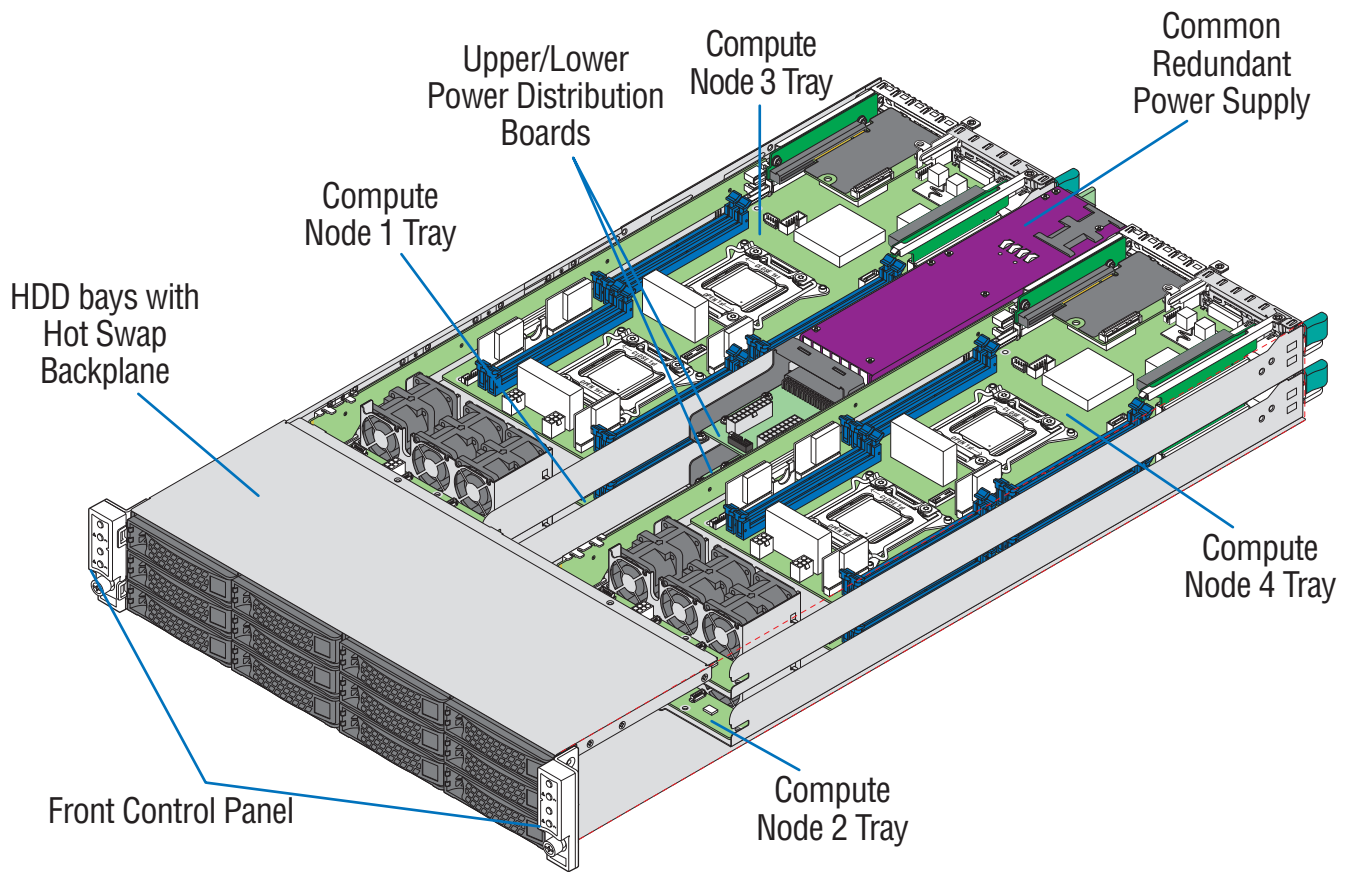

\* 3.5" Hard Drive Bay system as shown

# System Overview

## Intel® Server System H2000WP Family

### System Features and Components

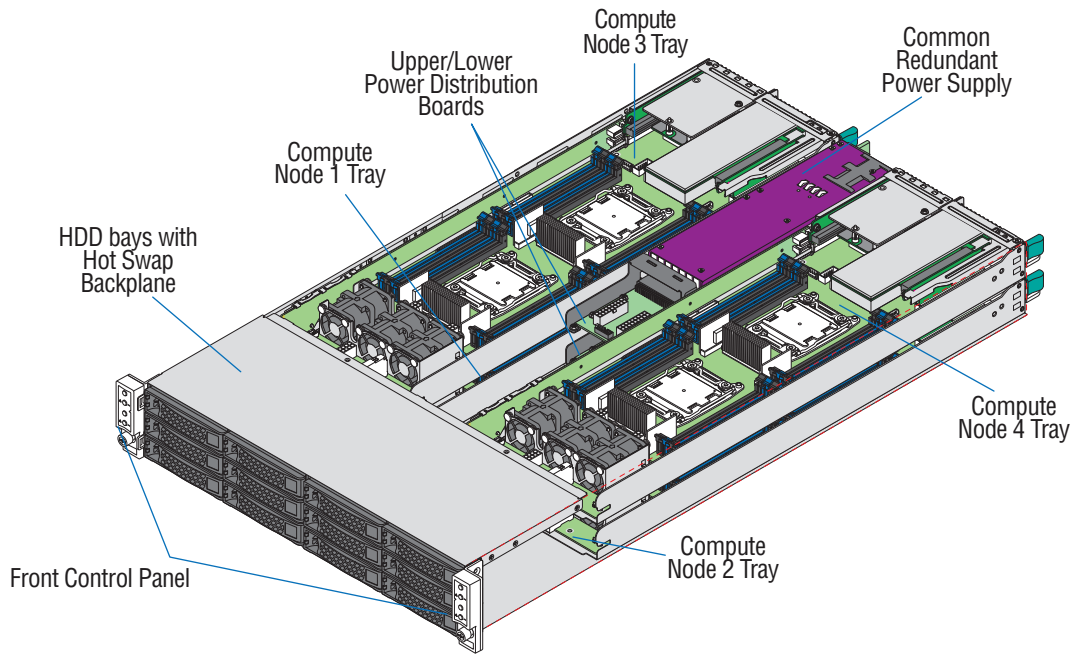

### Intel® Server System H2000JF and H2000WP Hard Drive Numbering Diagram

12X3.5" Hard Drive Bay Option - Front View

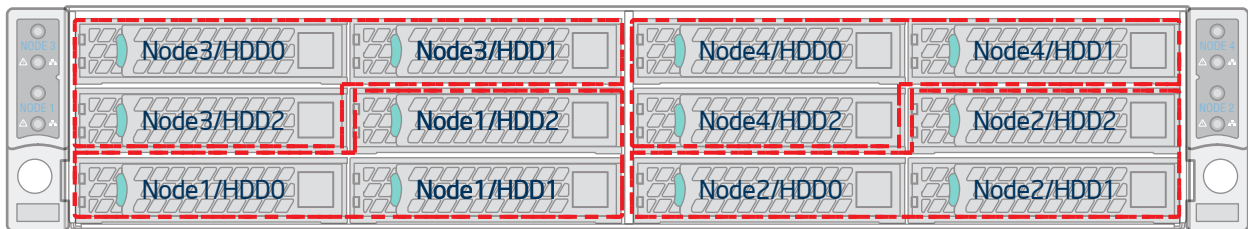

16X2.5" Hard Drive Bay Option - Front View

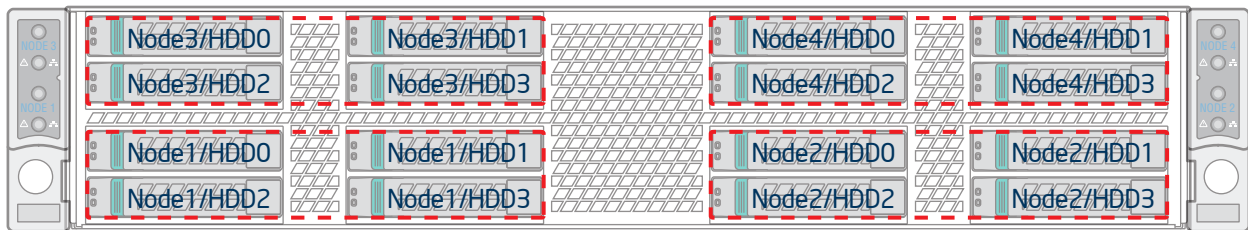

### Intel® Server System H2000JF and H2000WP Compute Node Numbering Diagram - Rear View

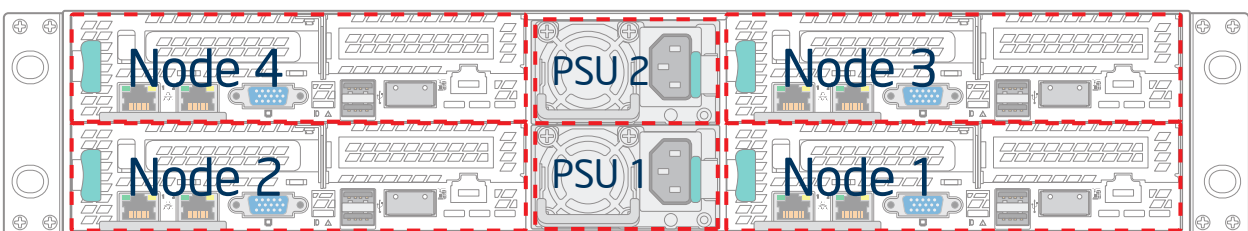

# General Installation Process

The installation instructions in this section are for common components of Intel® Server System H2000JP and H2000WP family.

## Minimum Hardware Requirements

To avoid integration difficulties and possible board damage, your system must meet the following minimum requirements:

- Processor:  
Intel® Xeon® processor E5-2600 product family (TDP 130W or below).
- Memory Type:  
Minimum of one 1GB DDR3 1066/1333/1600 MHz RDIMM.
- Hard Disk Drives: SATA/SAS

For a complete list of compatible processors, heatsinks, and memory, see [http://www.intel.com/p/en\\_US/support](http://www.intel.com/p/en_US/support) (post-production only)

# 1

## Preparing the System

Observe normal ESD (Electrostatic Discharge) procedures.



Place your Intel® Server System on a flat anti-static surface to perform the following integration procedures. Observe ESD procedures before reaching inside to make server board connections or install components.

# 2

## Install/Remove the Power Supply Unit

### Install the Power Supply Unit:

- Align and slide in the Power Supply Unit to the power cage rail.
- Push the Power Supply Unit along the rail until the latch locks in position with a "tick" sound.

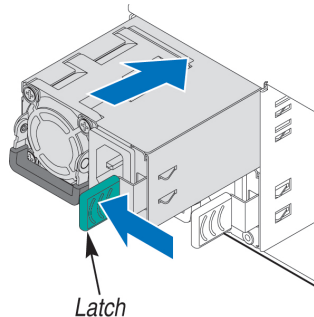

### Remove the Power Supply Unit:

- Carefully push in the latch on the right hand of PSU.
- Pull the handle with the PSU while still press the latch.

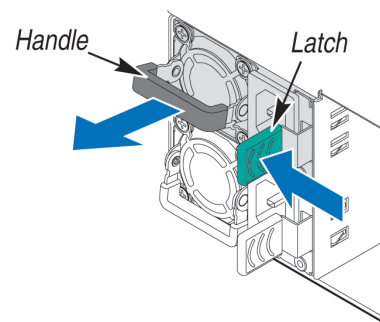

# 3

## Remove/Install Computer Node Tray

### To Remove Node Tray:

- Push-in the latch on the left hand of Node Tray.
- Pull the handle of the Node Tray while pushing the latch.

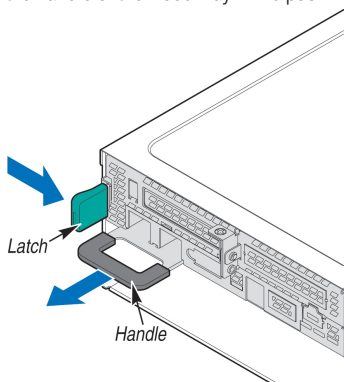

### To Install Node Tray:

- Align and slide in the Node Tray to the chassis rail.
- Push the Node Tray along the rail until the latch locks in position with a tick sound.

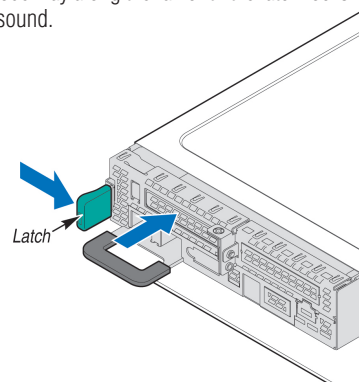

# General Installation Process

The installation instructions in this section are for common components of Intel® Server System H2000JP and H2000WP family.

## 4 Remove/Install Node Tray Air Duct

### Removing the Air Duct

- A** Press and hold both left and right side of rear air duct (see letter "A").
- B** Lift the rear end of the air duct slowly (see letter "B"). Rotate the airduct to more than 45 degrees up, and pull it out.

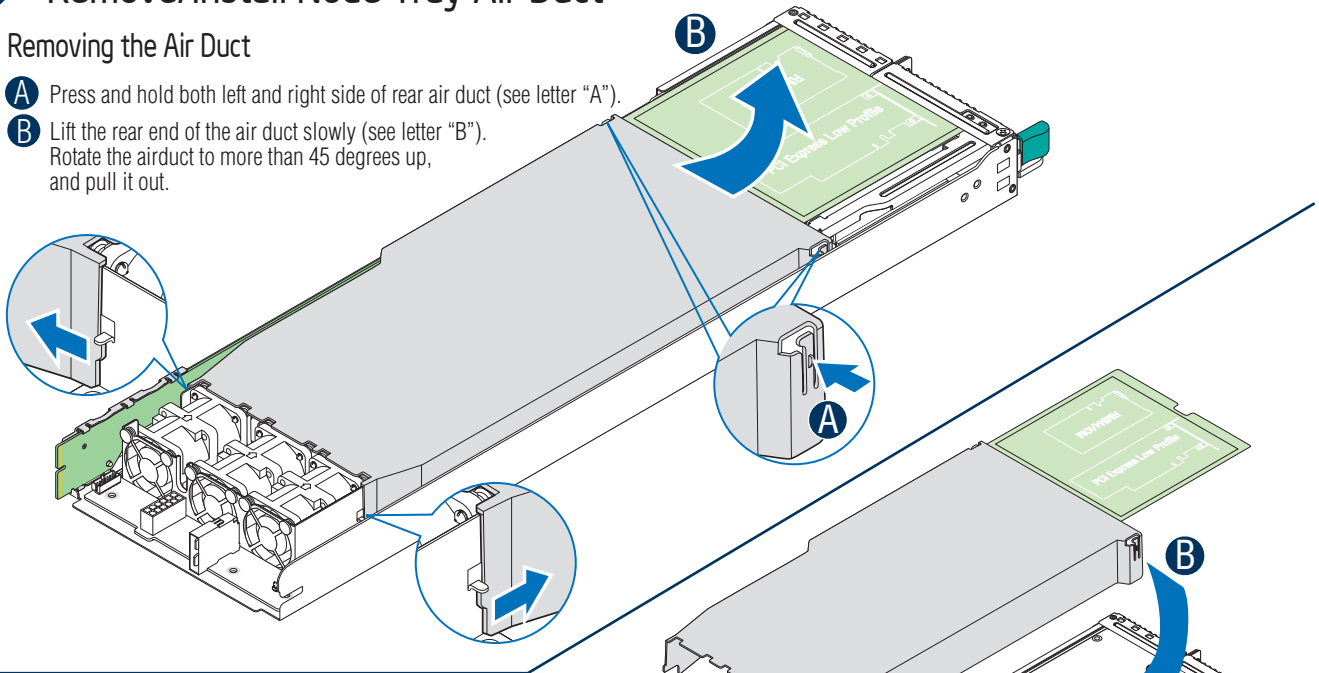

### Installing the Air Duct

- A** Align the front-end of air duct to chassis fixture (see letter "A").
- B** Low down the rear side of the air duct to fixture until a "tick" sound is heard (see letter "B").

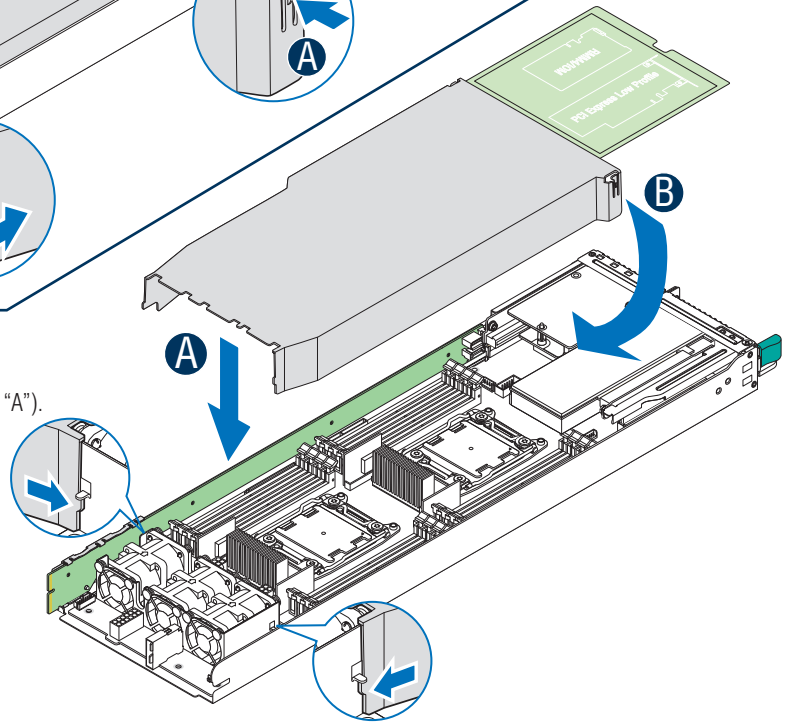

## IMPORTANT!

Before proceeding further, check your Intel® Server System for disconnected or loose cables and components that may have occurred during shipping.

## 5

### Remove Processor Heatsink(s)



**CAUTION:** The heatsink has thermal interface material (TIM) on the underside of it. Use caution so that you do not damage the thermal interface material. Use gloves to avoid sharp edges.

The heatsink is attached to the server board / processor socket with captive fasteners.

Using a #2 Phillips\* screwdriver, loosen the four screws located on the heatsink corners in a diagonal manner using the following procedure:

- A** Using a #2 Phillips\* screwdriver, start with screw 1 and loosen it by giving it two rotations and stop. (IMPORTANT: Do not fully loosen.)
  - B** Proceed to screw 2 and loosen it by giving it two rotations and stop. Similarly, loosen screws 3 and 4.
- Repeat steps A and B by giving each screw two rotations each time until all screws are loosened.
- C** Lift the heatsink straight up.

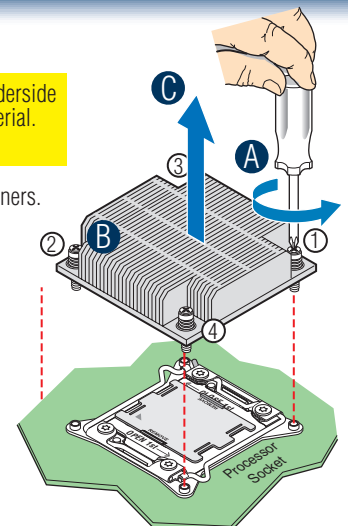



# General Installation Process

## 6

### Install the Processor(s)

#### A. Open the Socket Lever

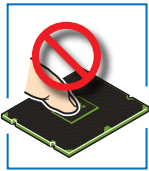
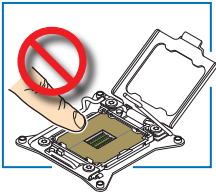

- A** Push down the lever handle on the **OPEN 1st** side and away from the socket to release it.
- B** Repeat the steps to release the lever on the other side.

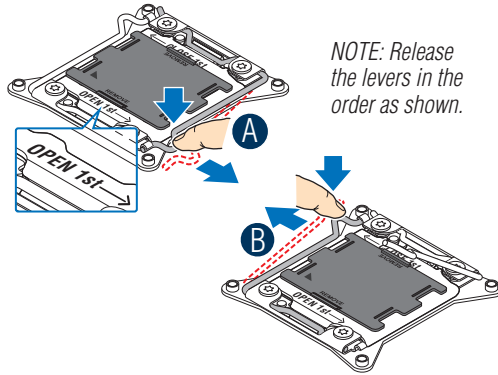

#### B. Open the Load Plate

- A** Press the locking lever slightly to raise the load plate.
- B** Open the load plate all the way.

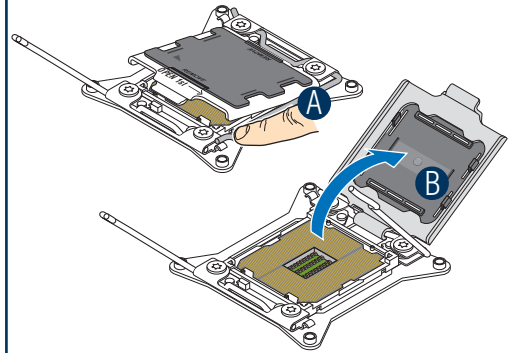

### Install the Processor(s) ... continued

#### C. Install the Processor



**CAUTION:** The underside of the processor has components that may damage the socket pins if installed improperly. Processor must align correctly with the socket opening before installation. **DO NOT DROP** processor into socket!

Components

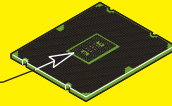

**CAUTION:** When unpacking a processor, hold by the edges only to avoid touching the gold contact pins.



Save the protective cover.

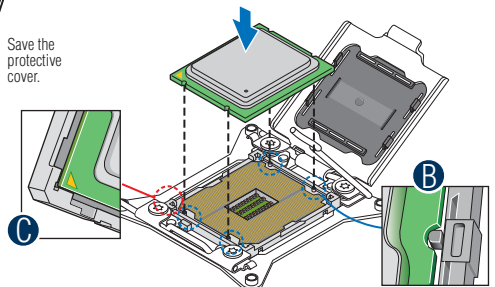

- A** Take the processor out of the box and remove the protective shipping cover.
- B** Orient the processor with the socket so that the processor cutouts match the four orientation posts on the socket.
- C** Note location of gold key at corner of processor.

### Install the Processor(s) ... continued

#### D. Remove the Cover

Press the cover to remove it.

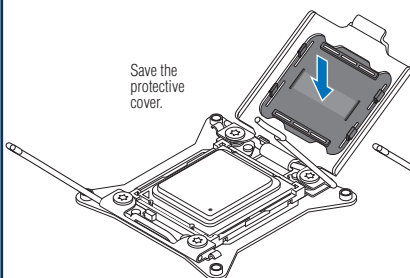

#### E. Close the Load Plate

Carefully lower the load plate over the processor.

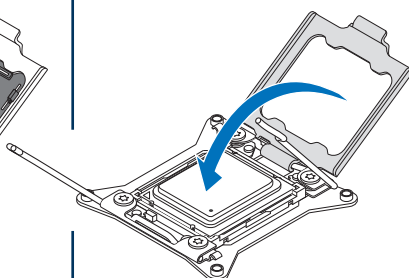

#### F. Latch the Locking Lever

- A** Push down on the locking lever on the **CLOSE 1st** side.
- B** Slide the tip of the lever under the notch in the load plate. *Make sure the load plate tab engages under the socket lever when fully closed.*
- C** Repeat the steps to latch the locking lever on the other side.

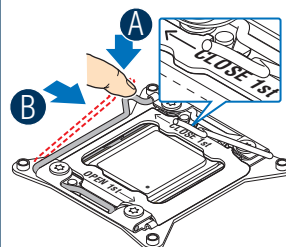

**NOTE:** Latch the levers in the order as shown.

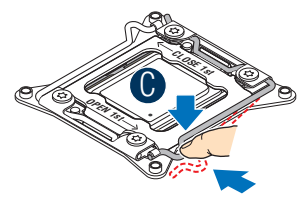

# General Installation Process

## 7

### Install Processor Heatsink(s)

**CAUTION:** The heatsink has thermal interface material (TIM) on the underside of it. Use caution so that you do not damage the thermal interface material. Use gloves to avoid sharp edges. CPU socket 1 heat sink is different from CPU socket 2 heat sink. In the Server System H2000JF family, **FXXA90X90HS** is for CPU socket 1 and **FXXE90X90HS** is for CPU socket 2. In the Server System H2000WP family, **FXXA84X106HS** is for CPU1, while **FXXE84X106HS** is for CPU2.\* Mis-locating the heatsink will cause serious thermal damage!

- A** Remove the protective film on the TIM if present.
- B** Align heatsink fins to the front and back of the chassis for correct airflow. Airflow goes from front-to-back of chassis.
- C** Using a #2 Phillips\* screwdriver, start with screw 1 and engage screw threads by giving it two rotations and stop. (Do not fully tighten.)
- D** Proceed to screw 2 and engage screw threads by giving it two rotations and stop. Similarly, engage screws 3 and 4.
- E** Repeat steps C and D by giving each screw two rotations each time until each screw is lightly tightened up to a maximum of 8 inch-lbs torque.

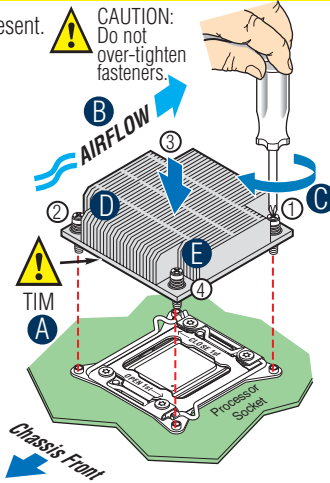

Note: Heatsink styles may vary.

## 8

### Install Memory Modules

#### DDR3 DIMM Memory Identification:

**CAUTION:** Observe normal ESD (ElectroStatic Discharge) procedures to avoid possible damage to system components.

DIMM notch and socket bump must align as shown below.

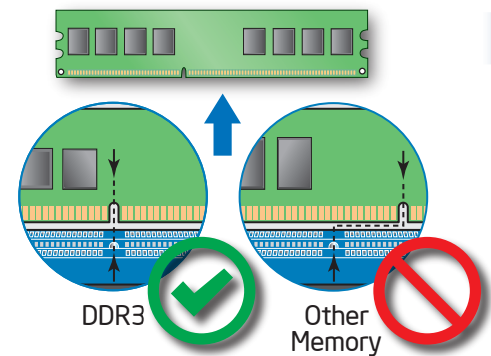

### Install Memory Modules ... Continued

#### Memory Configurations and Population Order:

#### Intel® Server Board S2600JF

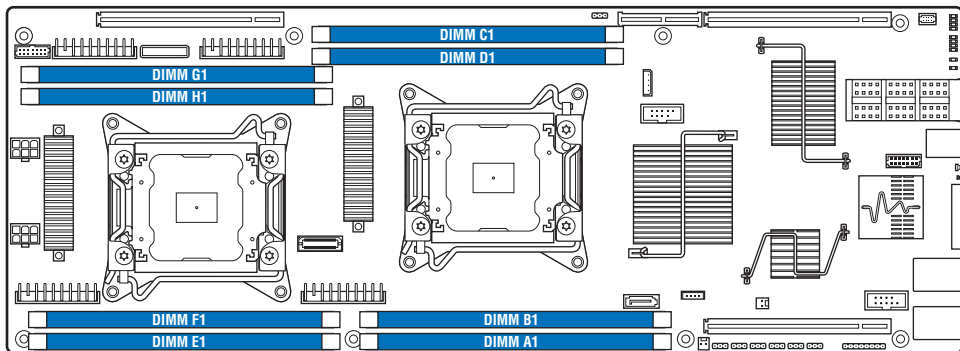

#### Intel® Server Board S2600WP

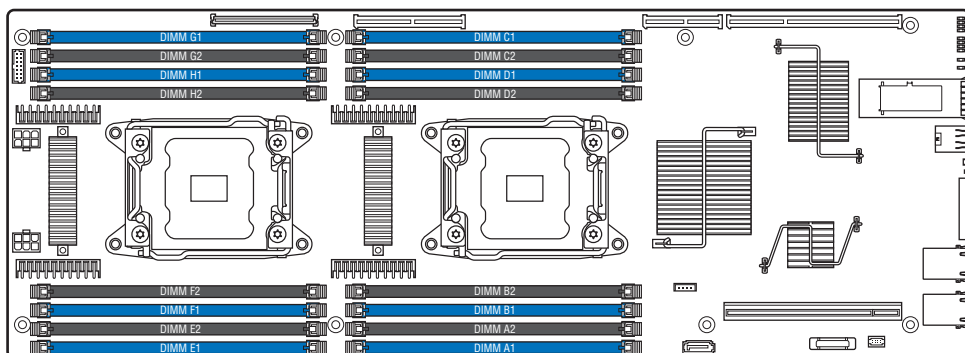

For best performance, a minimum of four DIMMs per CPU is recommended, populated in the blue slot of each memory channel.

In a single-processor configuration, always populate A1 DIMM first.

In a dual-processor configuration, always populate A1 DIMM first for CPU 1 and E1 DIMM first for CPU2.

**Note:** For additional memory configurations, see the Service Guide on the Intel® Server Deployment Toolkit CD that accompanied your Intel® Server Board S2600WP, or go to <http://www.intel.com/support/motherboards/server/>. (post-production)

Memory sizing and configuration is supported only for qualified DIMMs approved by Intel. For a list of supported memory, see the tested memory list at <http://www.intel.com/support/motherboards/server/>. (post-production)

# General Installation Process

## Install Memory Modules ... Continued

To Install DIMMs:

- A** Open both DIMM socket levers.
- B** Note location of alignment notch.
- C** Insert DIMM making sure the connector edge of the DIMM aligns correctly with the slot.
- D** Push down firmly on the DIMM until it snaps into place and both levers close.
- E** IMPORTANT! Visually check that each latch is fully closed and correctly engaged with each DIMM edge slot.

**CAUTION:** Avoid touching contacts when handling or installing DIMMs.

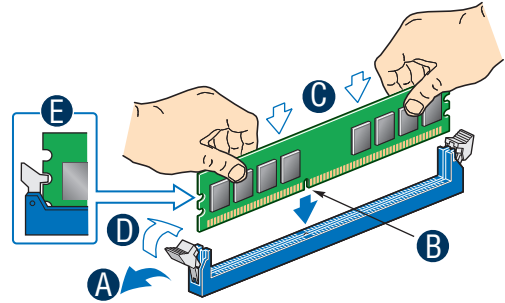

# 9

## Install/Remove the Front Bezel

**Remove the Front Bezel:**

- A** Unlock the bezel if it is locked. Remove the left end of front bezel from rack handle.
- B** Rotate the front bezel anticlockwise to release the latches on the right end from the rack handle.

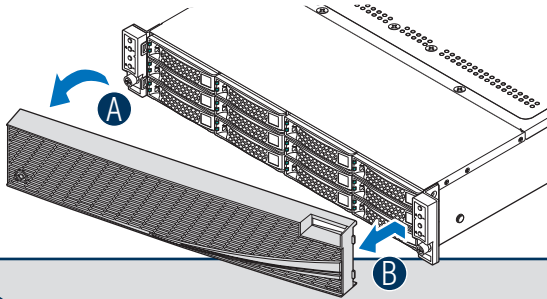

**Install the Front Bezel:**

**Note:** Before installing the bezel, you must install the rack handles.

- A** Lock the right end of the front bezel to the rack handle.
- B** Rotate the front bezel clockwise till the left end clicks into place.
- C** Lock the bezel if needed.

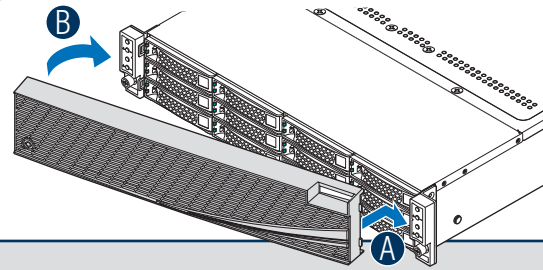

# 10

## Install Hard Drives

### 2.5" Hard Drive Carrier (For system with 2.5" hard drive bay only)

- A** Remove the drive carrier by pressing the green latch to unlock.
- B** Pull out the black lever and slide the carrier out.

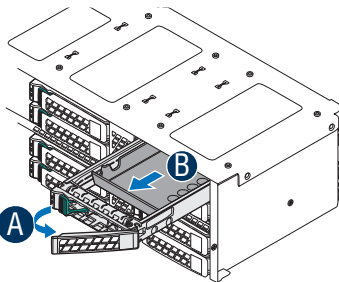

- C** Remove the four screws securing the plastic drive blank from the 2.5" HDD carrier.
- D** Disengage the plastic drive blank from the HDD carrier. Remove the plastic drive blank from the 2.5" HDD carrier.

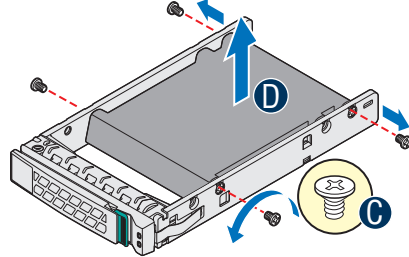

- E** Install the hard disk drive using the four screws as shown. Make Sure the connector end of the drive matches the backplane connector.

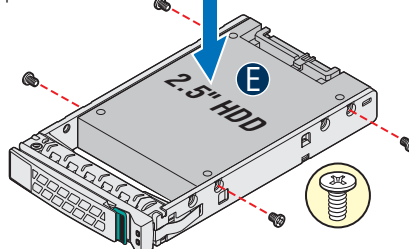

- F** With the lever open, insert the hard disk drive assembly into the chassis, then push in the lever to lock it into place.

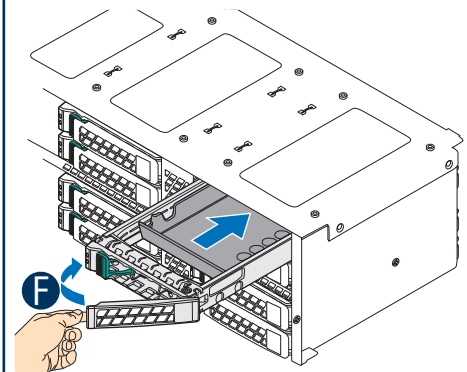

**CAUTION:** If you don't install all drives, empty drive bays must be occupied by carriers with plastic drive blank provided to maintain proper system cooling.



# General Installation Process

## Install Hard Drives ... Continued

### 3.5" Hard Drive Carrier (For system with 3.5" hard drive bay only)

- A** Remove the drive carrier by pressing the **green** button and opening the lever.
- B** Slide the carrier out.

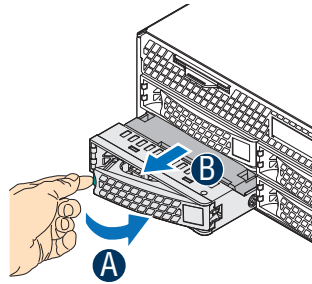

- C** Remove the four screws securing the HDD interface bracket and remove the HDD interface bracket.

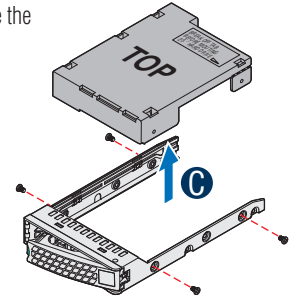

- D** Install the hard disk drive using the same four screws as shown. Make sure the connector end of the drive matches the backplane connector.

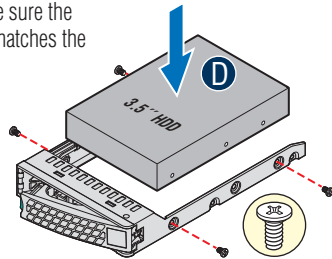

- E** With the lever open, insert the hard disk drive assembly into the chassis.

- F** Push in the lever to lock it into place.

**CAUTION:** If you don't install all drives, empty drive bays must be occupied by carriers with plastic drive blank provided to maintain proper system cooling.

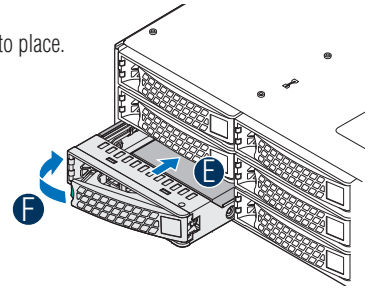

# 11

## Installing PCI Riser Assembly and Add-in Card on Riser Slot 1

- A** Install the riser to bracket by fastening screws in below drawings.

**To remove the PCI Add-in Card from Riser Slot 1:** Perform the five steps in reverse.

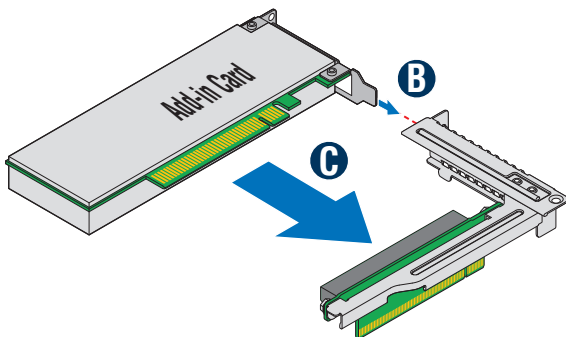

- D** Slide the card guide horizontally to lock in the back edge of the add-in card.
- E** Install the bracket assembly into the chassis with a screw.

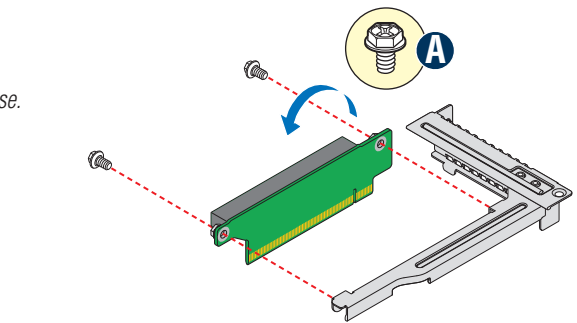

- B** Insert add-in card until it seats in the riser connector.
- C** Install the bracket assembly into the chassis with a screw.

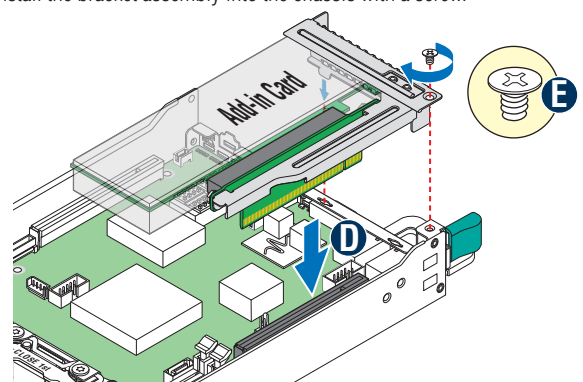

# General Installation Process

## 12 Install I/O Module Riser and Carrier Assembly on Riser Slot 2

1 Install Riser to riser bracket.

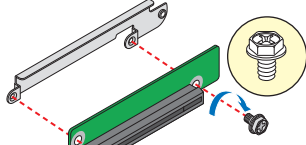

2 Install I/O Module to I/O Carrier and fasten with screw. (See letter "B")

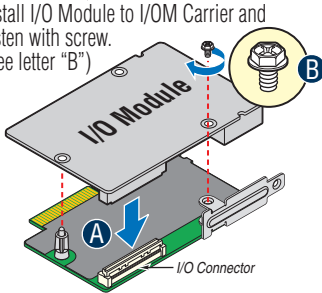

3 Attach IOM bracket to IOM carrier (see letter "D"), and then plug-in the IOM assembly into the riser slot. (See letter "C")

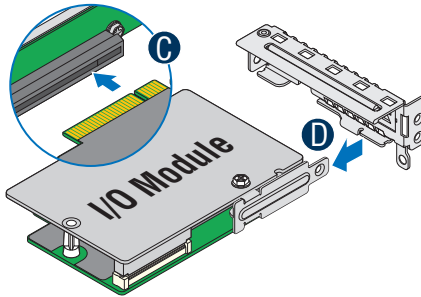

4 Install I/O assembly and add-in card assembly (if any) using screws. (See letters "F", "E", and "G")

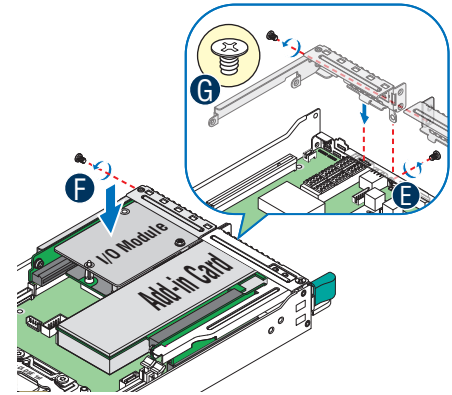

## 13 Install Intel® RAID C600 Upgrade Key (optional)

Locate the white 4-pin key header next to RISER SLOT\_1. Carefully pick up the Intel® RAID C600 Upgrade Key. Match the Key and connector orientation and press down to install.

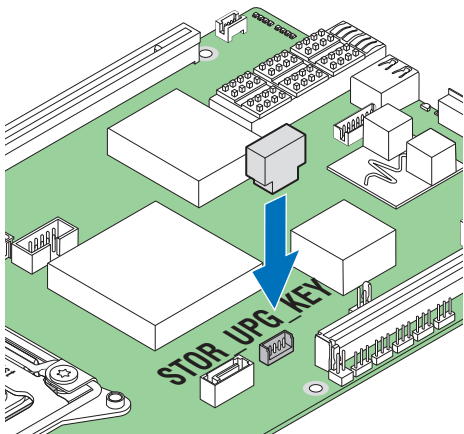

### Intel® RAID C600 Storage Upgrade Key Options for S2600JF and S2600WP

Intel® RAID C600 Upgrade Key Options (Intel Product Codes)	Key Color	Intel® RAID C600 Upgrade Key Description	S2600JF SCU RAID availability Description
Default – No option key installed	N/A	4 Port SATA with Intel® ESRT RAID 0,1,10 and Intel® RSTe RAID 0,1,5,10	4 Port SATA with Intel® ESRT RAID 0,1,10 and Intel® RSTe RAID 0,1,5,10
RKSATA4R5	Black	4 Port SATA with Intel® ESRT2 RAID 0,1, 5, 10 and Intel® RSTe RAID 0,1,5,10	4 Port SATA with Intel® ESRT2 RAID 0,1, 5, 10 and Intel® RSTe RAID 0,1,5,10
RKSAS4	Green	4 Port SAS with Intel® ESRT2 RAID 0,1, 10 and Intel® RSTe RAID 0,1,10	4 Port SAS with Intel® ESRT2 RAID 0,1, 10 and Intel® RSTe RAID 0,1,10
RKSAS4R5	Yellow	4 Port SAS with Intel® ESRT2 RAID 0,1, 5, 10 and Intel® RSTe RAID 0,1,10	4 Port SAS with Intel® ESRT2 RAID 0,1, 5, 10 and Intel® RSTe RAID 0,1,10

**Note:** The 8-port Storage Upgrade Key can also implement the RAID function for S2600JF, but only 4 ports (SCU) can be configured as proper RAID level.

## 14 Install Intel® Remote Management Module 4 (optional)

Locate the RMM4 Lite connector, carefully pick up the Intel® RMM4 Lite module, match the alignment pin of the module and the connector on server board, then press to install.

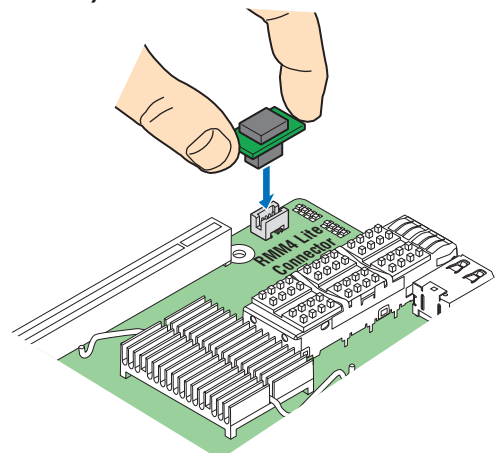

# General Installation Process

15

## Remove the Top Cover

- A Remove four screws.
- B Lift the cover upwards from B edge and pull to detach the latches.

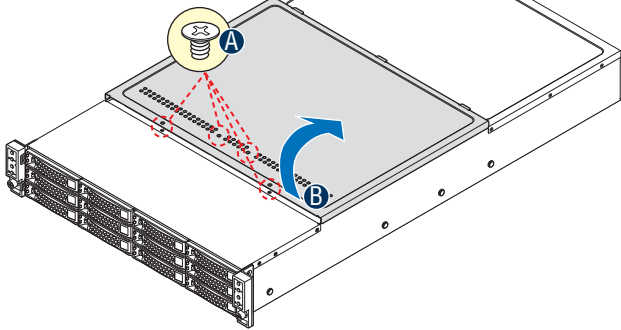

**Note:** Before removing the top cover, turn off all peripheral devices connected to the server, turn off the server, and disconnect the power cord.

16

## Install Top Cover

- A Place system cover onto the chassis and engage recessed edge at rear of cover.
- B Put down the cover from B edge and tighten the screw at front.

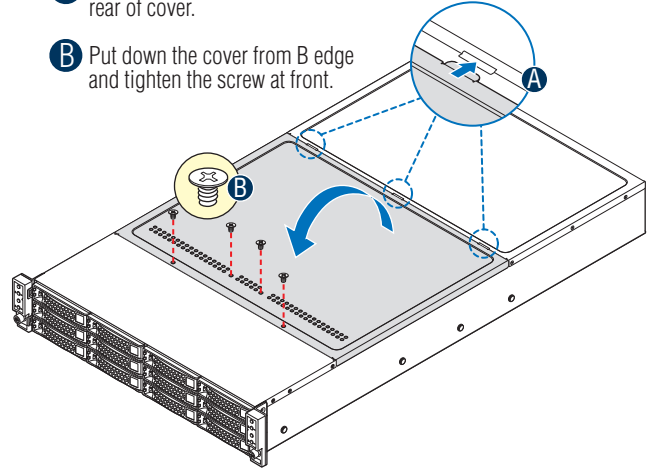

17

## Software • BIOS, Drivers, and Operating System Installation

### A. Update the System Software:

1. Boot from the Intel® Server Deployment Toolkit CD.
2. Use the Wizard to access the latest versions on the Internet and update the BIOS, firmware, FRUSDRs, and Intel® RMM4. *Note: You may also download files on a USB key.*  
*Note: The FRUSDR utility must be run for full server configuration.*

### B. Configure your RAID Controller:

If using a RAID card, use the instructions provided with the RAID controller. If using on-board RAID, you must activate RAID in the BIOS setup. See the *Intel® Server Board S2600GZ/GL Technical Product Specification* for more information.

### C. Install your Operating System:

Use the instructions provided with the RAID controller and with the operating system.

### D. Install Operating System Drivers:

With the operating system running, insert the Intel® Server Deployment Toolkit CD. If using a Microsoft Windows\* operating system, the Express Installer will autorun and allow you to select the appropriate drivers to install. On other operating systems, browse the CD folders to locate and install the driver files.

### E. Install Intel® System Management Software (optional):

Download the latest version of the Intel® System Management Software from <http://www.intel.com/go/servermanagement> and use the instructions provided at that link to install the software.

\* Other brands and names may be claimed as the property of others..

# General Installation Process

## Intel® Server Chassis H2000 Assembly and Disassembly

18

### Assembling the Server System with Server Chassis H2000

A. Removing the Node Dummy Tray

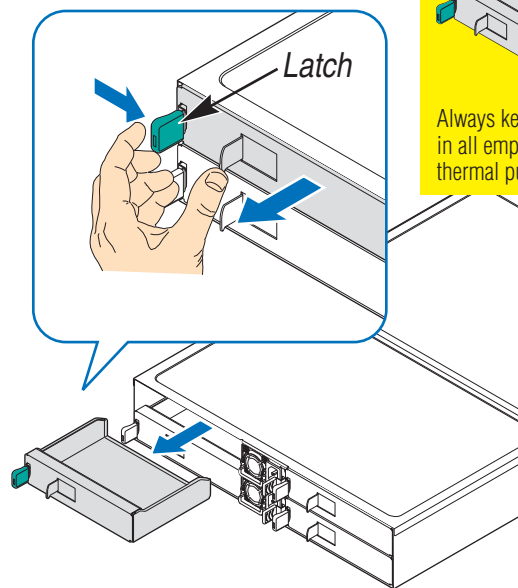

Node Dummy Tray

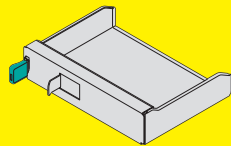

Always keep dummy trays in all empty node slots for thermal purpose.

B. Inserting the Node Tray

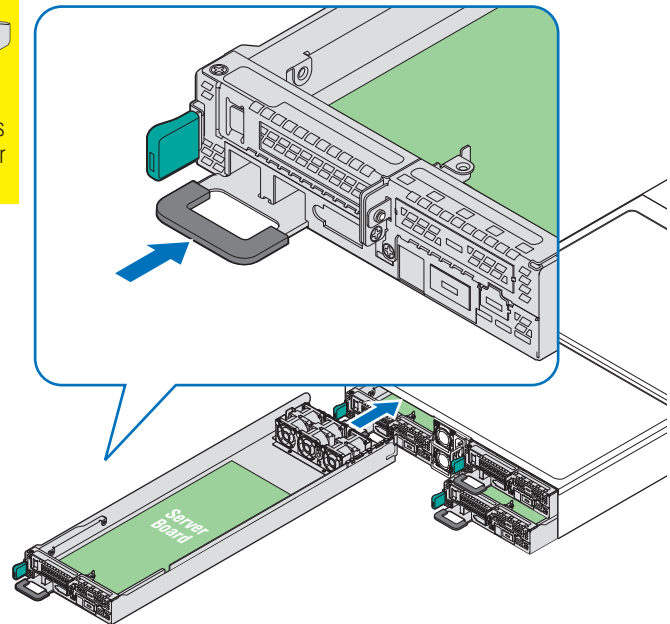

19

### Removing a Node Tray from a Chassis

A. Removing the Node Tray

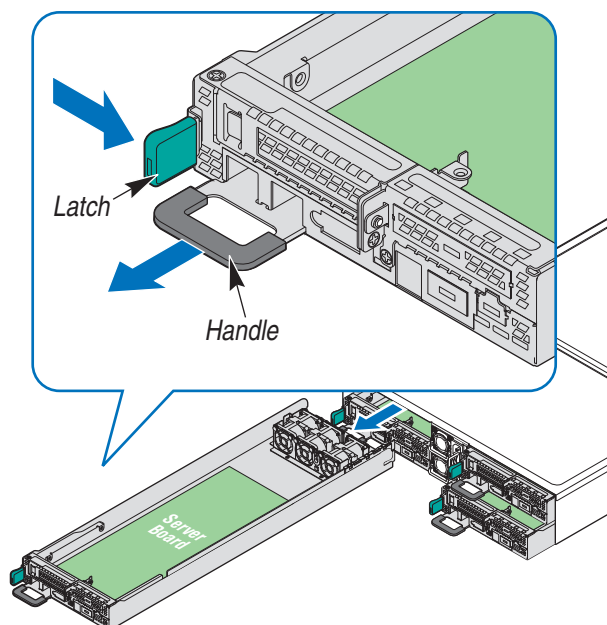

B. Inserting the Dummy Tray back

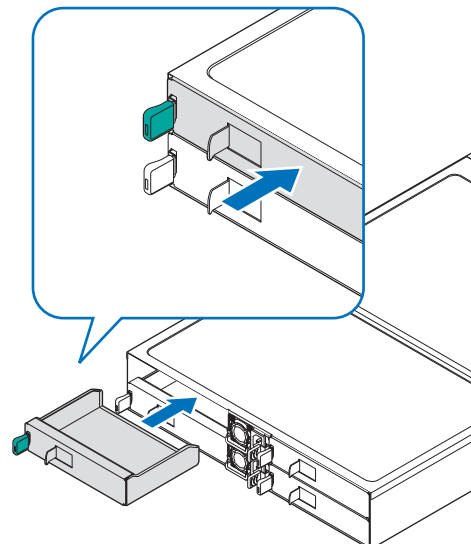

# Reference

## Intel® Server Board S2600JF Component Layout

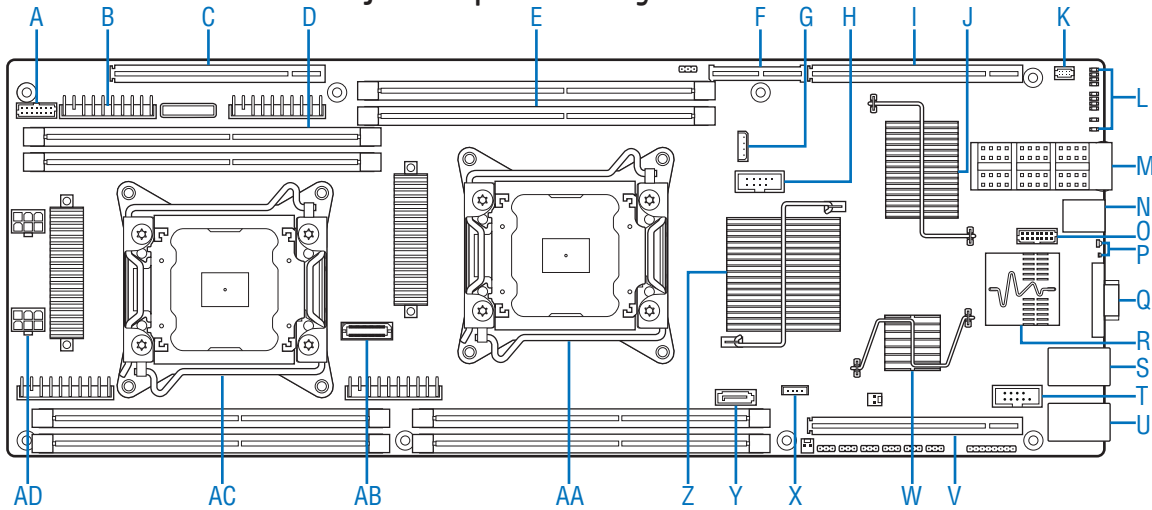

- |                                   |                       |                                   |
|-----------------------------------|-----------------------|-----------------------------------|
| A. 2x7 fan control connector      | K. RMM4 lite          | U. NIC Port 1                     |
| B. VRS (4 total)                  | L. POST and QSFP LED  | V. Riser Slot1 with PCIe Gen3 x16 |
| C. Riser Slot3 with PCIe Gen3 x16 | M. QSFP               | W. Integrated BMC                 |
| D. CPU2 DIMM (4 total)            | N. USB x2             | X. Storage Upgrade key            |
| E. CPU1 DIMM (4 total)            | O. Debug connector    | Y. SATA port 1                    |
| F. Bridge board connector         | P. Status & ID LED    | Z. PCH C600                       |
| G. IPMB                           | Q. VGA out            | AA. CPU 1                         |
| H. 2x5 USB                        | R. Dual port 1Gbe NIC | AB. XDP connector                 |
| I. Riser Slot2 with PCIe Gen3 x16 | S. NIC Port 2         | AC. CPU 2                         |
| J. Infiniband QDR or FDR          | T. Serial Port A      | AD. 2x3 PWR connector (2 total)   |

See your *Intel® Server System H2000JF Service Guide* for expanded component and connection information.

## Intel® Server Board S2600WP Component Layout

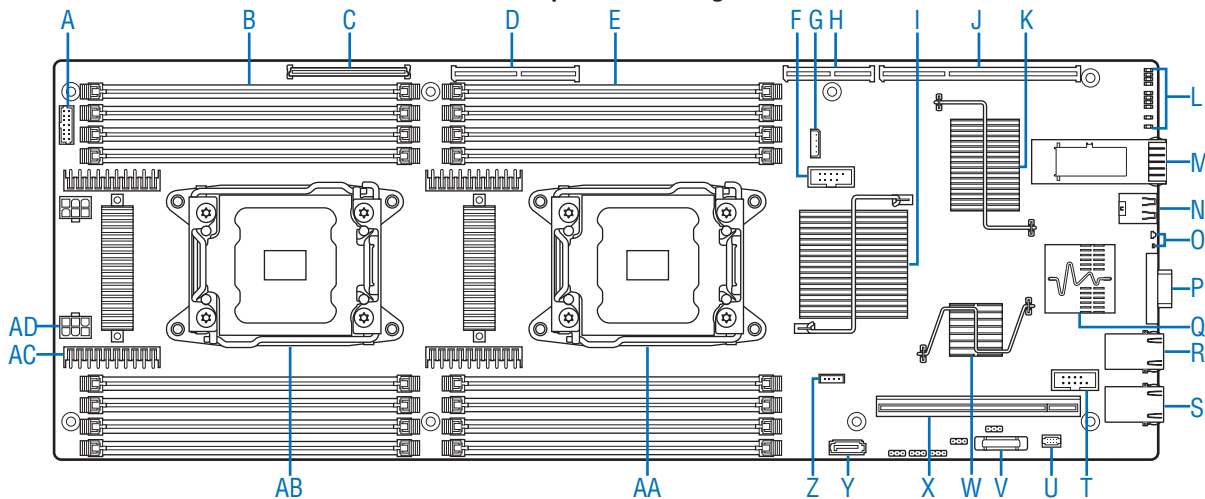

- |                                   |                            |                                 |
|-----------------------------------|----------------------------|---------------------------------|
| A. 2x7 fan control connector      | K. Infiniband QDR          | U. RMM4 lite                    |
| B. CPU2 DIMM (8 total)            | L. POST and QSFP LED       | V. CMOS battery                 |
| C. Riser Slot4 with PCIe Gen3 x16 | M. QSFP Port               | W. Integrated BMC               |
| D. Riser Slot 3 (PCIe Gen3x16)    | N. USB x2                  | X. Riser Slot 1 (PCIe Gen3x16)  |
| E. CPU1 DIMM (8 total)            | O. Status and ID LED       | Y. SATA port 1                  |
| F. 2x5 USB                        | P. VGA out                 | Z. Storage Upgrade key          |
| G. IPMB Connector                 | Q. Dual port 1GbE NIC chip | AA. CPU 1                       |
| H. Bridge board connector         | R. NIC port 2              | AB. CPU 2                       |
| I. PCH C600-A                     | S. NIC Port 1              | AC. VRS (4 total)               |
| J. Riser Slot 2 (PCIe Gen3x16)    | T. Serial Port A           | AD. 2x3 PWR connector (2 total) |

See your *Intel® Server System H2000JF Service Guide* for expanded component and connection information.

# Reference

## Front Panel Controls and Indicators

Your system may include one of two front control panel types. The features of each are as follows:

- A. System Power Button with LED
- B. System ID Button
- C. System Status LED
- D. Network Link/Activity LED

Standard Control Panel

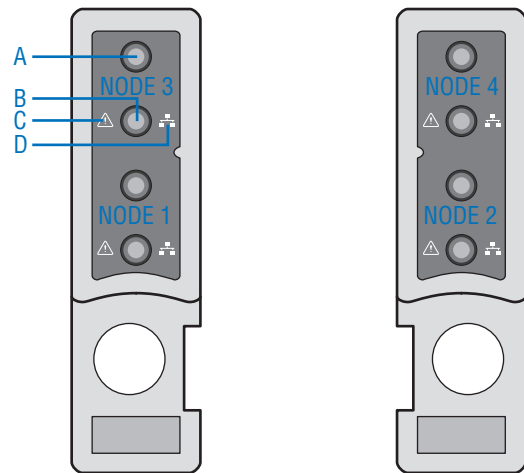

## Cable Routing inside Server System H2000JF Node Tray

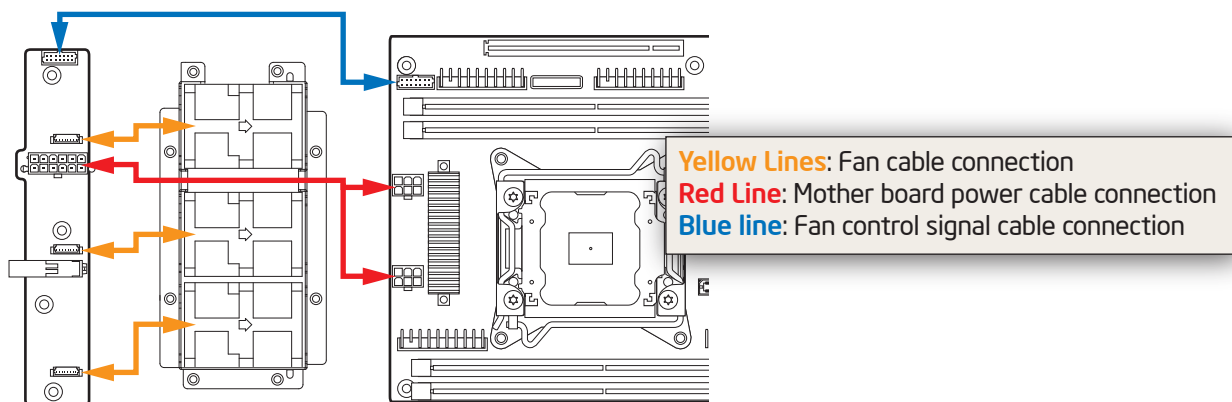

## Optional Accessories

Product Code	MM#	Description
HNS2600JF	918336	Intel Server Board S2600JF; Intel Node Power Board; Intel Bridge Board; 1U PCI Express Low Profile Riser; 1U Cu/AI 91mmx91mm Heat Sink; 1U Ex-AI 91mmx91mm Heat Sink; Three 4056 Dual Rotor Fan; Power Cable, Airduct; 1U Node Tray; Fan Control Signal Cable; No InfiniBand on board
HNS2600JFQ	918335	Intel Server Board S2600JFQ; Intel Node Power Board; Intel Bridge Board; 1U PCI Express Low Profile Riser; 1U Cu/AI 91mmx91mm Heat Sink; 1U Ex-AI 91mmx91mm Heat Sink; Three 4056 Dual Rotor Fan; Power Cable, Airduct; 1U Node Tray; Fan Control Signal Cable; InfiniBand QDR port on board
HNS2600JFF	921301	Intel Server Board S2600JFF; Intel Node Power Board; Intel Bridge Board; 1U PCI Express Low Profile Riser; 1U Cu/AI 91mmx91mm Heat Sink; 1U Ex-AI 91mmx91mm Heat Sink; Three 4056 Dual Rotor Fan; Power Cable, Airduct; 1U Node Tray; Fan Control Signal Cable; InfiniBand FDR port on board
H2312XXJR	919020	12 x 3.5" HDD bay chassis only, with 2 x 1200W PSU and 4 blank node fillers
H2216XXJR	919021	16 x 2.5" HDD bay chassis only, with 2 x 1200W PSU and 4 blank node fillers
H2312XXKR	919022	12 x 3.5" HDD bay chassis only, with 2 x 1600W PSU and 4 blank node fillers
H2216XXKR	919023	16 x 2.5" HDD bay chassis only, with 2 x 1600W PSU and 4 blank node fillers
AXXRMM4IOM	918249	PCI Express x16 rIOM Riser; RMM4/rIOM carrier board

A complete list of accessories and spares can be found at [http://www.intel.com/p/en\\_US/support](http://www.intel.com/p/en_US/support). (post-production only)



# Reference

## Cable Routing inside Server System H2000WP Node Tray

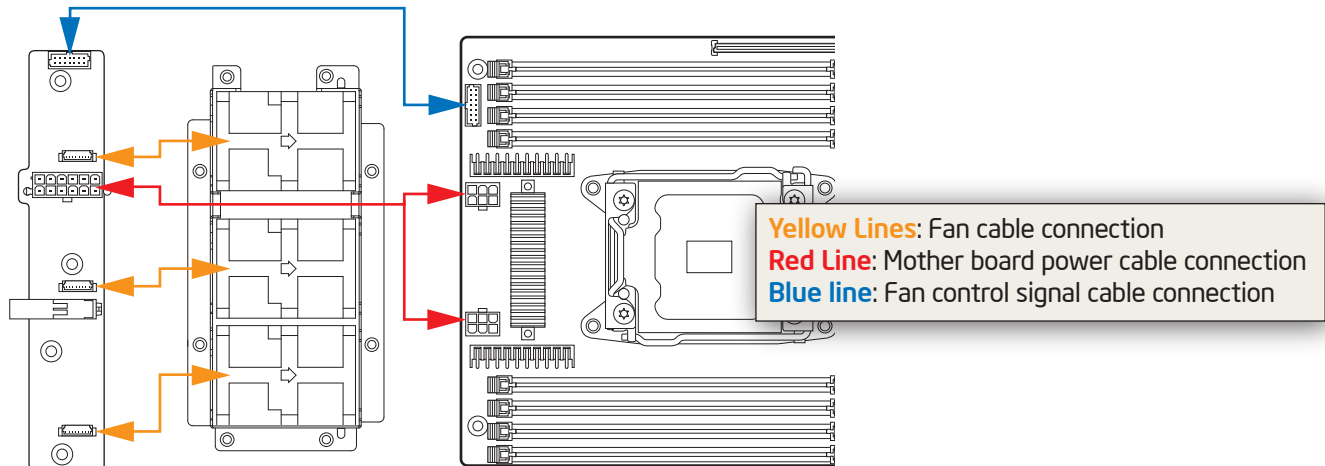

## Optional Accessories

Product Code	MM#	Description
HNS2600WP	918378	Intel Server Board S2600WP; Intel Node Power Board; Intel Bridge Board; 1U PCI Express Low Profile Riser; 1U Cu/Al 84mmx106mm Heat Sink; 1U Ex-Al 84mmx106mm Heat Sink; Three 4056 Dual Rotor Fan; Power Cable, Airduct; 1U Node Tray; Fan Control Signal Cable; No InfiniBand on board
HNS2600WPQ	918377	Intel Server Board S2600WPQ; Intel Node Power Board; Intel Bridge Board; 1U PCI Express Low Profile Riser; 1U Cu/Al 84mmx106mm Heat Sink; 1U Ex-Al 84mmx106mm Heat Sink; Three 4056 Dual Rotor Fan; Power Cable, Airduct; 1U Node Tray; Fan Control Signal Cable; InfiniBand QDR port on board
HNS2600WPF	921314	Intel Server Board S2600WPF; Intel Node Power Board; Intel Bridge Board; 1U PCI Express Low Profile Riser; 1U Cu/Al 84mmx106mm Heat Sink; 1U Ex-Al 84mmx106mm Heat Sink; Three 4056 Dual Rotor Fan; Power Cable, Airduct; 1U Node Tray; Fan Control Signal Cable; InfiniBand FDR port on board
H2312XXJR	919020	12 x 3.5" HDD bay chassis only, with 2 x 1200W PSU and 4 blank node fillers
H2216XXJR	919021	16 x 2.5" HDD bay chassis only, with 2 x 1200W PSU and 4 blank node fillers
H2312XXKR	919022	12 x 3.5" HDD bay chassis only, with 2 x 1600W PSU and 4 blank node fillers
H2216XXKR	919023	16 x 2.5" HDD bay chassis only, with 2 x 1600W PSU and 4 blank node fillers
AXXRMM4IOMW	918304	PCI Express x16 riOM Riser; RMM4/riOM carrier board

A complete list of accessories and spares can be found at: [http://www.intel.com/p/en\\_US/support](http://www.intel.com/p/en_US/support) (post-production only)

## Intel® Server System RAID Options

**Intel® RSTe**

Intel® RSTe (also known as Intel® Rapid Storage Technology Enterprise) is an embedded software RAID solution based on the Intel Chipset RAID Stack for on-server board SAS and SATA ports. It provides pass-through drive support as well as host based RAID 0/1/10 support and RAID 5 support for the SATA ports.

**Intel® ESRT2**

Intel® ESRT2 (also known as Intel® Embedded Server RAID Technology II) is an embedded software RAID solution based on the LSI MegaRAID\* Stack for on-server board SAS and SATA ports. It supports RAID 0/1/10 and optional RAID 5 with the proper Intel® RAID C600 upgrade keys.

**Intel® Integrated RAID Modules**

Intel® Integrated RAID Modules connects to the on-board SAS Module Connector or a module enabled PCI-E slot. This is a cost-effective RAID solution providing more system design flexibility.

**Must be purchased separately**

**Add-in RAID Adapters**

Standard SAS or RAID HBA available from Intel® or 3<sup>rd</sup> Party suppliers. See Intel® Server Configurator Tool (<http://serverconfigurator.intel.com>) for the most up-to-date adapter support list for your system.

**Must be purchased separately**

## Intel® Server System RAID Options

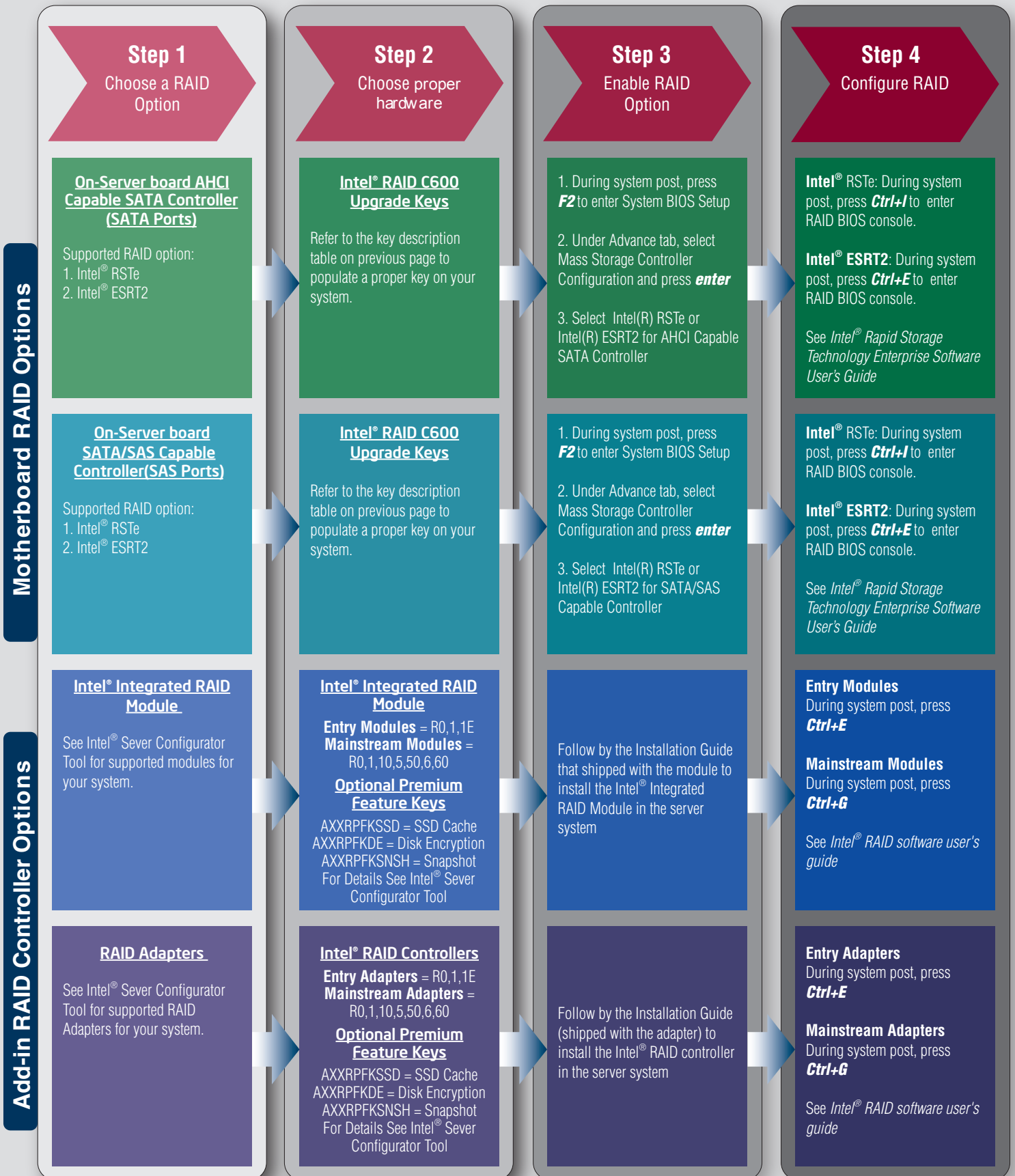





G54451-002

