

Intel® Server Board S3420GP Quick Start User's Guide

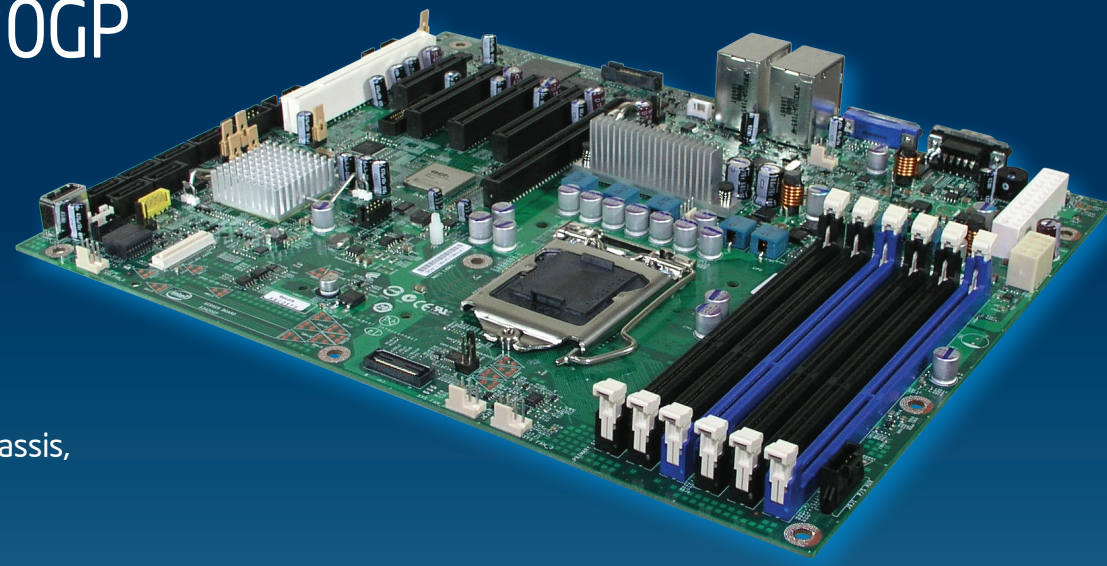

Thank you for buying the Intel® Server Board S3420GP. The following information will help you integrate your new server board into a server chassis. The Intel® Server Board S3420GP is designed for use with the Intel® Server Chassis SC5650UP.

For details on these chassis or to select a third party chassis, please visit <http://www.intel.com/go/serverbuilder> and <http://www.intel.com/support/motherboards/server>.

When installing the server board into a reference chassis, refer to the reference chassis instructions.

User Guides are also available on the Intel® Server Deployment Toolkit CD that accompanied your Intel® Server Board S3420GP.

If you are not familiar with ESD (Electrostatic Discharge) procedures used during system integration, please see the Intel® Server Board S3420GP User's Guide, available on the Intel® Server Deployment Toolkit CD or at <http://www.intel.com/motherboards/server/s3420gp>.

Please boot to the Intel® Server Deployment Toolkit CD first for BIOS and firmware configuration and updates.

Read all cautions and warnings first before starting your server system integration.

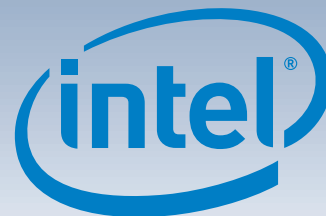

Minimum Hardware Requirements

To avoid integration difficulties and possible board damage, your system must meet the following minimum requirements:

- Processor: Intel® Xeon® Processor 3400 Series with compatible heat sink.
- Memory Type: Minimum of one 1 GB, 240-pin DDR3 800/1066/1333 MHz RDIMM or 1066/1333 MHz UDIMM.
- Power: Minimum of 350 W with 3A of standby current, which meets the SSI EPS 5V specification.

Tools Required

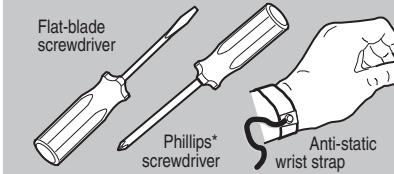

Fastener Identification Guide

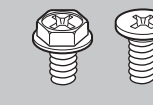

1 Preparing the Chassis

If using a non-Intel server chassis, refer to the documentation that came with your chassis for preparatory steps.

Observe normal ESD (ElectroStatic Discharge) procedures.

Place your Intel® Server Chassis and Intel® Server Board on a flat anti-static surface to perform the following integration procedures. Always touch the chassis frame first, before reaching inside to install the server board, make server board connections or install other components.

2 Installing the I/O Shield and Attach I/O Labels

Note: The I/O shield and label installation procedures shown below apply to the Intel® Server Chassis SC5650UP.

Attach the Labels to the I/O Shield (optional)

Note: Make sure you install the labels on the correct side of the I/O shield. Note the orientation of the cutouts in the drawing before attaching your labels.

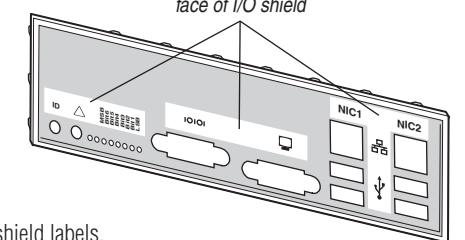

- Remove the backing from one of the three I/O shield labels included with your server board.
- Press the label onto the I/O shield as shown.
- Repeat steps to install the second and third I/O shield labels.

Install the I/O shield

Shield installs from inside of chassis. The labels should be visible from the outside of the chassis.

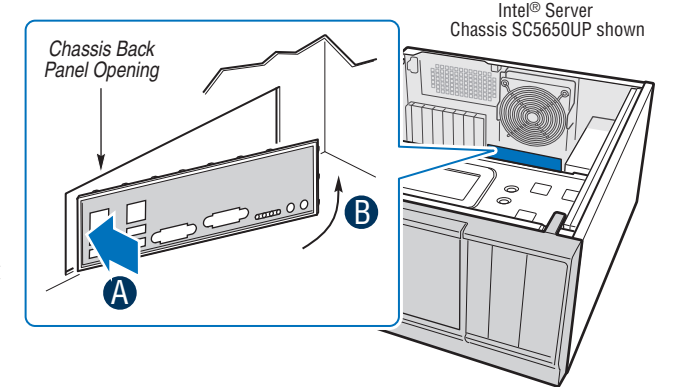

- Insert one side edge of shield as shown.
- Push shield firmly into chassis opening until it clicks into place.

3 Install Server Board Bumpers

IMPORTANT NOTE: If you are using a non-Intel server chassis that includes bumpers, refer to the chassis documentation for bumper installation. If you are using a non-Intel server chassis that does not include bumpers, consult with the chassis vendor to determine if bumpers are required or not. If you are using an Intel® Server Chassis, use the chassis bumpers that came with the chassis.

Prepare Server Board

- Rotate board to show underside and hold upright as shown.

CAUTION: To avoid damage to the server board, do not lay flat with the component side down.

- Locate the six circles as shown.

Attach the Bumpers

- Remove the backing from each bumper.
- Press a bumper onto each of the six circles.

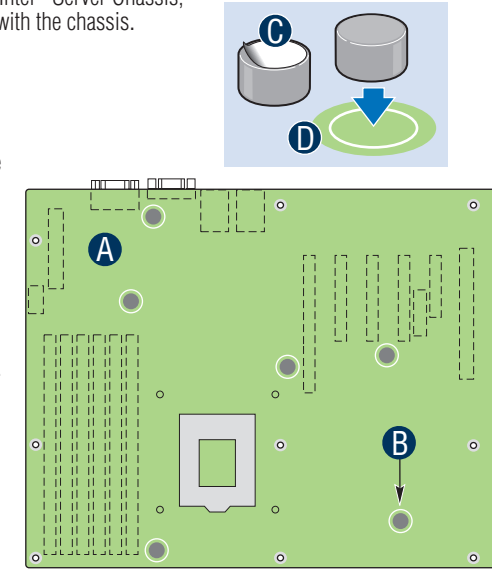

Warning

Read all caution and safety statements in this document before performing any of the instructions. Also see the Intel® Server Board and Server Chassis Safety Information document at: <http://www.intel.com/support/motherboards/server/sb/cs-010770.htm> for complete safety information.

Warning

Installation and service of this product should only be performed by qualified service personnel to avoid risk of injury from electrical shock or energy hazard.

Caution

Observe normal ESD [Electrostatic Discharge] procedures during system integration to avoid possible damage to server board and/or other components.

4 Install the Server Board

IMPORTANT NOTE: If you are using a non-Intel server chassis, see your chassis documentation for preparatory steps prior to server board installation.

A. Insert the Server Board

Place the board into the chassis, making sure that back panel I/O openings and chassis standoffs align correctly.

- When using the Intel® Server Chassis SC5650UP, insert the front of the board first, then slide the board back so the I/O connectors fit through the I/O openings at the rear of the chassis.

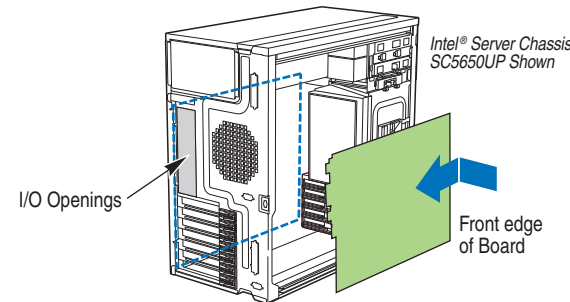

B. Attach the Server Board

The directions below are for the Intel® Server Chassis SC5650UP. For a non-Intel server chassis, use the fasteners that came with your chassis.

Use screws to attach the board to the chassis at the 9 locations indicated by the solid blue arrows in the figure.

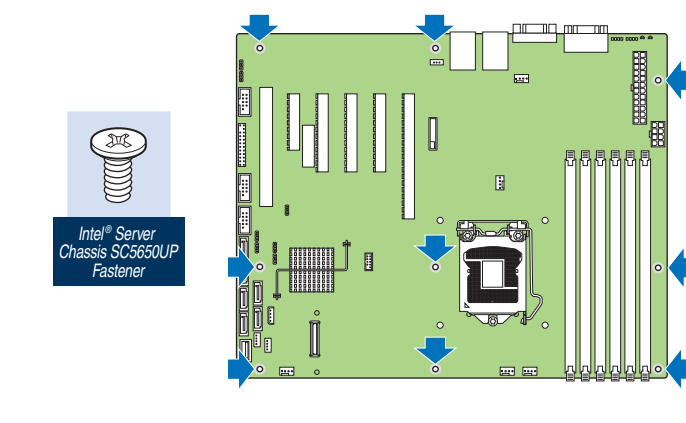

5 Install the Processor

Cautions:

- A** When removing the protective cover, DO NOT TOUCH the gold socket wires.
- B** To avoid damage, DO NOT DROP the cover onto the socket wires or components.
- C** When unpacking a processor, hold by the edges only to avoid touching the gold contact wires.

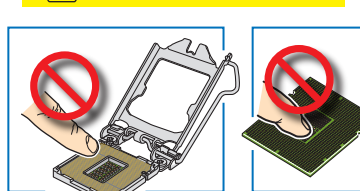

A. Open the Socket Lever

- Push the lever handle down and away from the socket to release it.

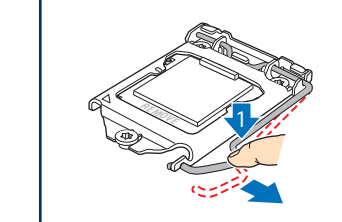

B. Open the Load Plate

- Open the load plate as shown.

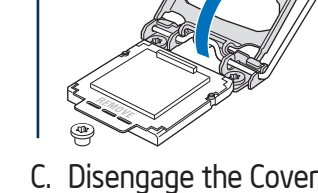

D. Remove the Cover

- Carefully lift the cover straight up as shown.

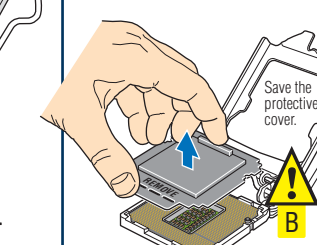

C. Disengage the Cover

- Place thumb and finger as shown and tilt up slightly at front.

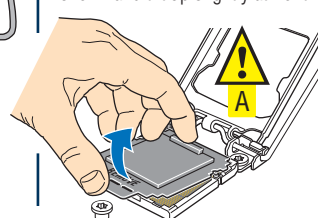

E. Unpack the Processor

- Carefully remove protective cover as shown.



F. Install the Processor

CAUTION: The underside of the processor has components that may damage the socket wires if installed improperly. Processor must align correctly with the socket opening before installation. DO NOT DROP processor into socket!

- Orient the processor with the socket so that the processor cutouts match the two socket pins.

- Note location of gold key at corner of processor.

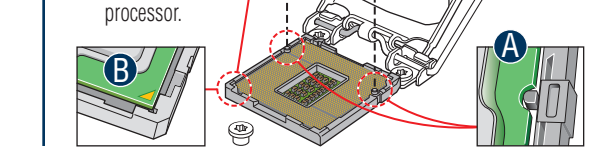

Install the Processor ... continued

G. Close the Load Plate

Carefully lower the load plate over the processor.

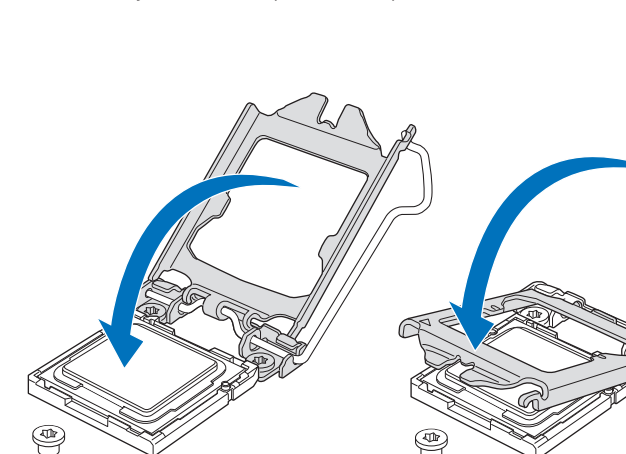

H. Engage the Load Plate

- Make sure the front edge of the load plate slides under the shoulder screw as the lever is lowered.

- Close the load plate locking lever.

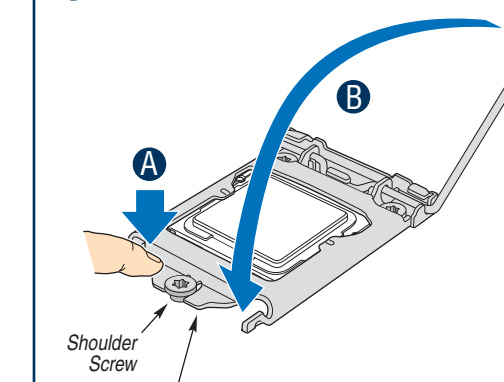

I. Latch the Locking Lever

- Push down on the locking lever.

CAUTION: DO NOT damage the server board with the tip of the locking lever.

- Slide the tip of the lever under the notch in the load plate. Make sure the lever is securely latched.

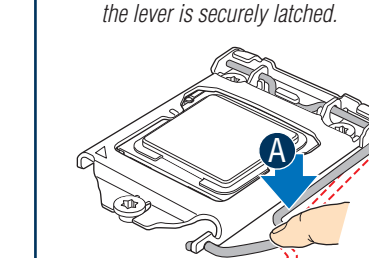

6 Install Active Heat Sink(s)

An active heat sink is required for the Intel® Entry Server Chassis SC5650UP. A typical active heat sink is shown at right. Rotate the active heat sink so that the power connector can reach the CPU fan header on the server board.

CAUTION: The heat sink has thermal interface material (TIM) on the underside of it. Use caution so that you do not damage the thermal interface material. Use gloves to avoid sharp edges.

- Make sure the screwdriver slot at the top of each fastener is rotated perpendicular to the blades of the heat sink as shown.

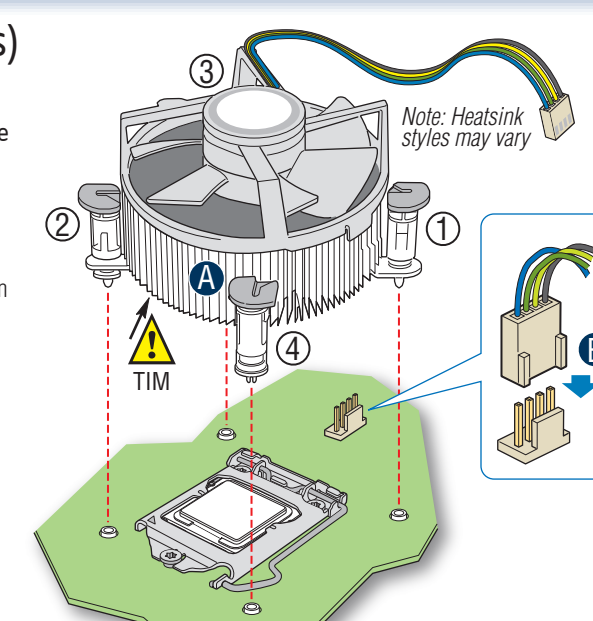

- Align heat sink with holes in board and lower assembly to board. Snaps go through holes in server board.

Repeat B-D for each fastener in the numerical order shown at left.

- Press downward on top of cap.

- Fastener snaps into final position.

- Plug the fan cable into the CPU fan header.

E73397-003



Intel is a registered trademark of Intel Corporation or its subsidiaries in the United States and other countries. *Other names and brands may be claimed as the property of others. Copyright © 2009, Intel Corporation. All rights reserved.