



# **Intel<sup>®</sup> Server Systems SR1530CL / SR1530HCL / SR1530HCLS and SR1530CLR / SR1530HCLR / SR1530HCLSR**

## ***Technical Product Specification***

*Intel order number D71005-004*

**Revision 2.1**

**September 2007**

**Enterprise Platforms and Services Division - Marketing**

---

## Revision History

# Revision History

Date	Revision Number	Modifications
Sept. 2006	1.0	Initial release.
Jan. 2007	2.0	Added Intel® Server Systems SR1530HCL / SR1530HCLS and made regulatory updates.
Sept. 2007	2.1	Updated product codes and processor information.

## Disclaimers

Information in this document is provided in connection with Intel® products. No license, express or implied, by estoppel or otherwise, to any intellectual property rights is granted by this document. Except as provided in Intel's Terms and Conditions of Sale for such products, Intel assumes no liability whatsoever, and Intel disclaims any express or implied warranty, relating to sale and/or use of Intel products including liability or warranties relating to fitness for a particular purpose, merchantability, or infringement of any patent, copyright or other intellectual property right. Intel products are not intended for use in medical, life saving, or life sustaining applications. Intel may make changes to specifications and product descriptions at any time, without notice.

Designers must not rely on the absence or characteristics of any features or instructions marked "reserved" or "undefined." Intel reserves these for future definition and shall have no responsibility whatsoever for conflicts or incompatibilities arising from future changes to them.

This document contains information on products in the design phase of development. Do not finalize a design with this information. Revised information will be published when the product is available. Verify with your local sales office that you have the latest datasheet before finalizing a design.

The server boards / systems referenced in this document may contain design defects or errors known as errata which may cause the product to deviate from published specifications. Current characterized errata are available on request.

Intel, Pentium, Itanium, and Xeon are trademarks or registered trademarks of Intel Corporation.

\*Other brands and names may be claimed as the property of others.

Copyright © Intel Corporation 2007. All rights reserved.

## Table of Contents

<b>1. Introduction</b>	<b>1</b>
1.1 System Views	1
1.2 System Dimensions	2
1.3 System Components	3
1.4 System Boards	5
1.5 Hard Drive and Peripheral Bays	5
1.6 Power Sub-System	7
1.7 System Cooling	8
1.8 Rack and Cabinet Mounting Options	8
<b>2. Power Sub-System</b>	<b>9</b>
2.1 Mechanical Overview	9
2.2 Output Connectors	10
2.2.1 P1 – Main Power Connector	10
2.2.2 P2 – Processor Power Connector	11
2.2.3 P3 – Baseboard Signal Connector	11
2.2.4 P4 and P5 – SATA Hard Drive Power Connectors	11
2.2.5 P6 – CD Power Connector	12
2.2.6 P7 – HSBP Power Connector	12
2.3 Efficiency	12
2.4 AC Input Voltage Requirement	12
2.5 Protection Circuits	13
2.5.1 Over-current Protection (OCP)	13
2.5.2 Over-voltage Protection (OVP)	13
2.5.3 Over-temperature Protection (OTP)	14
2.6 AC Power Cord Specification Requirements	14
<b>3. Cooling Sub-System</b>	<b>15</b>
3.1 Power Supply Fans	16
3.2 Processor Air Duct and Air Baffle	16
<b>4. Peripheral and Hard Drive Support</b>	<b>18</b>
4.1 Optical Drive Support	19
4.1.1 Optical Drive Support	19
4.2 Hard Disk Drive Support	20

## Table of Contents

4.2.1	Hot-Swap Hard Disk Drive Trays .....	20
4.2.2	Drive Blanks.....	21
4.2.3	System Fan Connectors .....	22
<b>5.</b>	<b>Front Control Panel.....</b>	<b>23</b>
5.1.1	Power / Sleep LED .....	25
5.1.2	System Status LED.....	25
5.1.3	Drive Activity LED .....	26
<b>6.</b>	<b>PCI Riser Cards and Assembly .....</b>	<b>27</b>
<b>7.</b>	<b>Backplane Board .....</b>	<b>28</b>
7.1.1	Hard Drive Activity LED .....	30
<b>8.</b>	<b>Supported Intel® Server Boards.....</b>	<b>32</b>
8.1	Intel® Server Board S5000VCL Feature Set.....	32
<b>9.</b>	<b>Environmental and Regulatory Specifications .....</b>	<b>33</b>
9.1	System Level Environmental Limits .....	33
9.2	Serviceability and Availability.....	33
9.3	Replacing the CMOS Battery.....	34
9.4	Product Regulatory Compliance .....	35
9.5	Use of Specified Regulated Components.....	35
9.6	Electromagnetic Compatibility Notices .....	37
9.6.1	USA .....	37
9.6.2	FCC Verification Statement .....	38
9.6.3	ICES-003 (Canada) .....	38
9.6.4	Europe (CE Declaration of Conformity) .....	38
9.6.5	Japan EMC Compatibility .....	39
9.6.6	BSMI (Taiwan) .....	39
9.6.7	RRL (Korea).....	39
9.6.8	CNCA (CCC-China) .....	40
9.7	Product Ecology Compliance.....	40
9.8	Other Markings .....	42
<b>Appendix A: Integration and Usage Tips.....</b>		<b>44</b>
<b>Appendix B: POST Code Diagnostic LED Decoder .....</b>		<b>45</b>
<b>Appendix C: POST Error Beep Codes.....</b>		<b>49</b>
<b>Glossary.....</b>		<b>50</b>
<b>Reference Documents .....</b>		<b>51</b>

## List of Figures

Figure 1. Intel® Server System SR1530CL/SR1530CLR (SATA) .....	1
Figure 2. Intel® Server Systems SR1530HCL/SR1530HCLR (SATA) and SR1530HCLS/SR1530HCLSR (SAS) .....	2
Figure 3. Major System Components - SR1530CL/SR1530CLR (SATA).....	3
Figure 4. Major System Components - SR1530HCL/SR1530HCLR (SATA) and SR1530HCLS/SR1530HCLSR (SAS) .....	4
Figure 5. Back Panel Features .....	5
Figure 6. Drive Bays (SR1530CL/SR1530CLR) .....	6
Figure 7. Drive Bays - SR1530HCL/SR1530HCLR (SATA) and SR1530HCLS/SR1530HCLSR (SAS).....	7
Figure 8. Power Supply Mechanical Drawing .....	9
Figure 9. Fan Module Assembly - SR1530CL/SR1530CLR (SATA).....	15
Figure 10. Fan Module Assembly - SR1530HCL/SR1530HCLR (SATA) and SR1530HCLS/SR1530HCLSR (SAS) .....	16
Figure 11. Air Baffle (SR1530CL/SR1530CLR) .....	17
Figure 12. Air Baffle (SR1530HCL/SR1530HCLR) .....	17
Figure 13. Drive Bays SR1530CL/SR1530CLR (SATA).....	18
Figure 14. Drive Bays - SR1530HCL/SR1530HCLR (SATA) and SR1530HCLS/SR1530HCLSR (SAS).....	19
Figure 15. Hard Drive Tray Assembly .....	21
Figure 16. Drive Tray with Drive Blank .....	21
Figure 17. Front Control Panel - SR1530CL/SR1530CLR (SATA).....	23
Figure 18. Front Control Panel - SR1530HCL/SR1530HCLR (SATA) and SR1530HCLS/SR1530HCLSR (SAS) .....	24
Figure 19. PCI Riser Card Assembly .....	27
Figure 20. Hot Swap Passive Backplane - SR1530HCL/SR1530HCLR (SATA) and SR1530HCLS/SR1530HCLSR (SAS) .....	28
Figure 21. Diagnostic LED Placement Diagram Example .....	45

## List of Tables

Table 1. Intel® Server System SR1530CL/SR1530CLR Dimensions .....	2
Table 2. Intel® Server Systems SR1530HCL/SR1530HCLR and SR1530HCLS/SR1530HCLSR Dimensions.....	2
Table 3. Cable Harness Definition .....	10
Table 4. P1 – Main Power Connector Pin-out.....	10
Table 5. P2 – Processor Power Connector Pin-out .....	11
Table 6. P3 – Baseboard Signal Connector Pin-out .....	11
Table 7. P4 and P5 – SATA Hard Drive Power Connector Pin-out.....	11
Table 8. P6 – CD Power Connector Pin-out .....	12
Table 9. P7 – CD Power Connector Pin-out .....	12
Table 10. Power Supply Efficiency .....	12
Table 11. AC Input Rating.....	13
Table 12. Over-current Protection (OCP) .....	13
Table 13. Over-Voltage Protection (OVP) Limits .....	14
Table 14. Cooling Zones.....	16
Table 15. 44-pin Internal IDE Connector Pin-out.....	20
Table 16. System Fan Connector Pin-outs .....	22
Table 17. Control Panel LED Functions.....	24
Table 18. SSI Power LED Operation .....	25
Table 19. Control Panel LED Operation .....	25
Table 20. Passive SATA/SAS Backplane Power Connector Pin-out (J7).....	28
Table 21. Passive SATA/SAS Backplane Connector to Hard Drive Pin-out (J1, J2, J3) .....	29
Table 22. Passive SATA/SAS Backplane I/O Connector to Baseboard Pin-out (J4, J5, J6) .....	29
Table 23. System Environmental Limits Summary .....	33
Table 24. Product Safety & Electromagnetic (EMC) Compliance .....	36
Table 25: POST Progress Code LED Example .....	45
Table 26. Diagnostic LED POST Code Decoder .....	46
Table 27. POST Error Beep Codes .....	49
Table 28. BMC Beep Codes .....	49



# 1. Introduction

---

The Intel® Server Systems SR1530CL/SR1530CLR and SR1530HCL/SR1530HCLR are 1U server systems that are designed to support the Intel® Server Board S5000VCL/S5000VCLR (SATA). The Intel® Server System SR1530HCLS/SR1530HCLSR is designed to support the Intel® Server Board S5000VCLSASBB/BBS5000VCLSASR (SAS). The server boards and the systems have features that are designed to support the high-density server market. This chapter provides a high-level overview of the system features. Greater detail for each major system component or feature is provided in the following chapters.

## 1.1 System Views



Figure 1. Intel® Server System SR1530CL/SR1530CLR (SATA)





Figure 2. Intel® Server Systems SR1530HCL/SR1530HCLR (SATA) and SR1530HCLS/SR1530HCLSR (SAS)

## 1.2 System Dimensions

Table 1. Intel® Server System SR1530CL/SR1530CLR Dimensions

Height	1.69 inches
Width without rails	17 inches
Depth without CMA	20 inches
Maximum weight	22 pounds

Table 2. Intel® Server Systems SR1530HCL/SR1530HCLR and SR1530HCLS/SR1530HCLSR Dimensions

Height	1.70 inches
Width without rails	16.92 inches
Depth without CMA	25.51 inches (excluding hard drive carriers, front control panel bezel, rack handles and front bezel)
Maximum weight	23 pounds

### 1.3 System Components

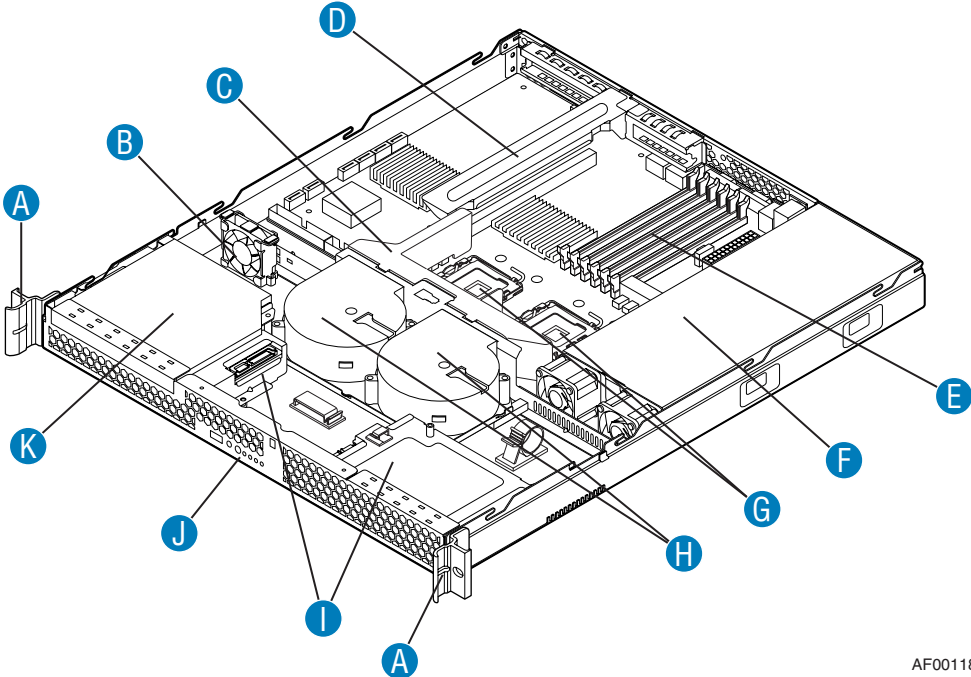

AF001185

A	Rack handles (two)	G	Processor sockets (two)
B	PCI cooling fan	H	System blower fans (two)
C	Processor air duct	I	Hard drives (two)
D	PCI add-in card bracket	J	Control panel
E	System memory DIMM sockets	K	Slimline optical drive
F	Power supply		

Figure 3. Major System Components - SR1530CL/SR1530CLR (SATA)

## Introduction

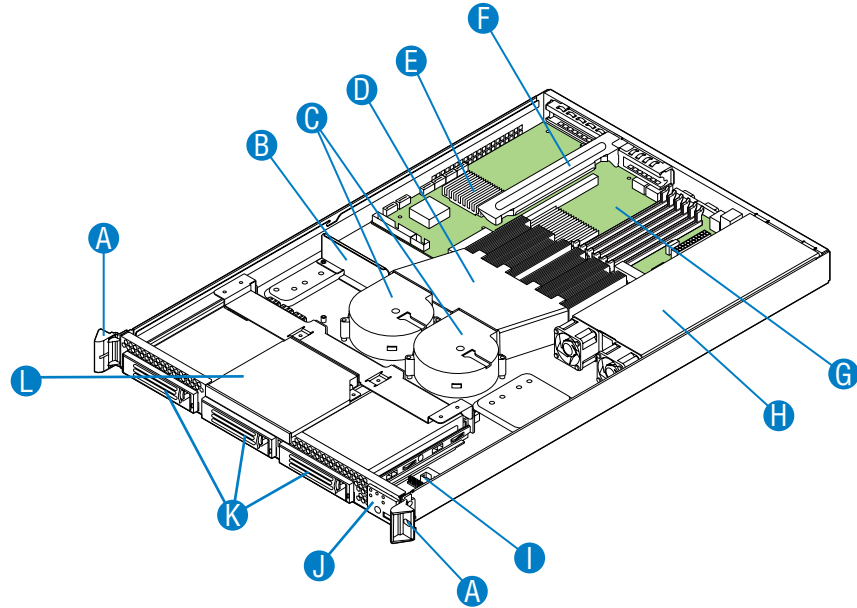

AF001612

A	Rack handles (two)	G	Server board
B	PCI air baffle	H	Power supply
C	System blower fans (two)	I	Front panel board
D	Processor air duct	J	Control panel
E	System memory DIMM sockets	K	Hot-swap hard drives (three)
F	PCI riser assembly	L	Slimline optical drive

**Figure 4. Major System Components - SR1530HCL/SR1530HCLR (SATA) and SR1530HCLS/SR1530HCLSR (SAS)**

**Note:** The I/O connector locations on the back of the chassis are pre-cut, making an I/O shield unnecessary. The supplied EMI gasket must be installed to maintain electromagnetic interference (EMI) compliance levels.

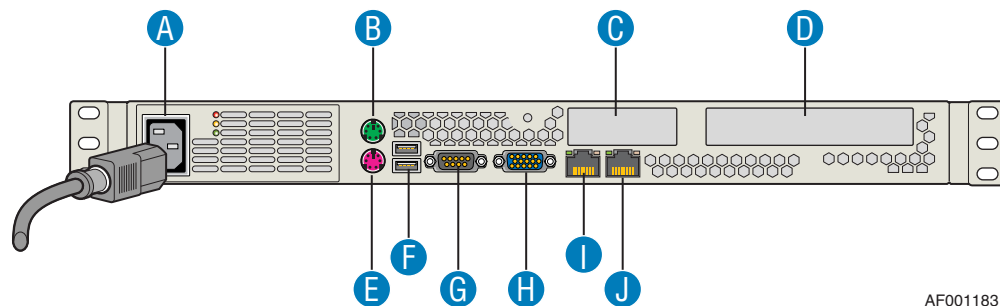

AF001183

A	AC Power Connector	F	USB Ports 0 and 1
B	Mouse Socket	G	Serial Port A
C	PCI Express* Slot	H	Video Connector
D	PCI-X* Slot	I	NIC 1 Connector (10 / 100 / 1000 Mb)
E	Keyboard Socket	J	NIC 1 Connector (10 / 100 / 1000 Mb)

**Figure 5. Back Panel Features**

## 1.4 System Boards

The system includes system boards that are used as internal interconnects and provide feature accessibility. The following provides a brief description for each.

Riser card – The system supports one PCI riser card that supports up to two add-in cards:

- One low-profile PCI Express\* x8 and one mid-height PCI-X\* 133
- Or one low-profile PCI Express\* x4 and one mid-height PCI Express\* x4.

## 1.5 Hard Drive and Peripheral Bays

The Intel® Server System SR1530CL/SR1530CLR is designed to support up to two fixed 3.5-inch SATA (Serial ATA) hard drives and one slimline optical device.

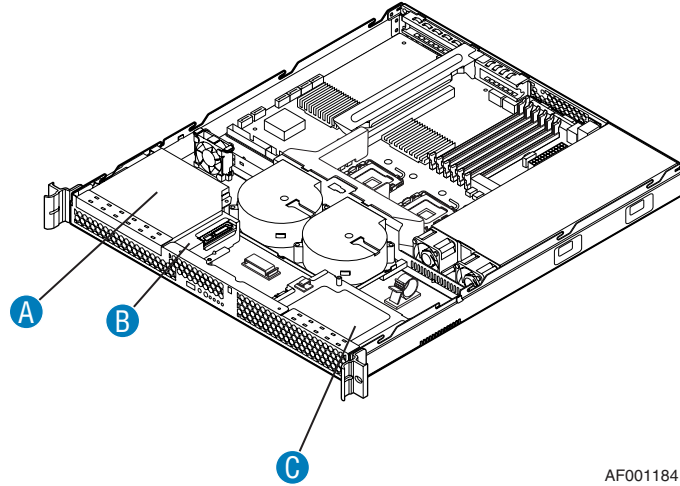

AF001184

A	Slimline optical drive bay
B	Hard drive bay HDD0 (located under the slimline optical drive bay)
C	Hard drive bay HDD1

**Figure 6. Drive Bays (SR1530CL/SR1530CLR)**

The Intel® Server Systems SR1530HCL/SR1530HCLR and SR1530HCLS/SR1530HCLSR are designed to support up to three hot-swap SATA (Serial ATA) or SAS hard drives and one slimline optical device.

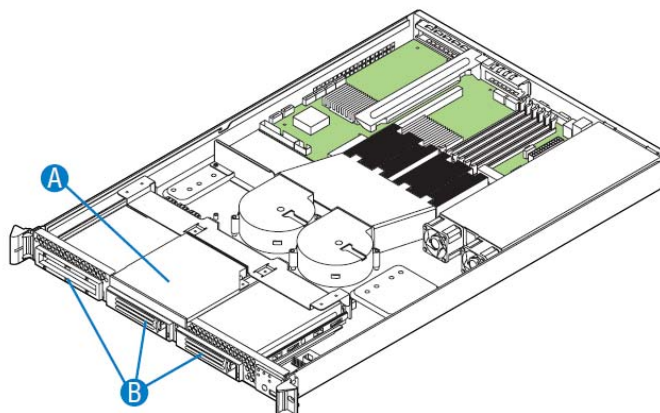

AF001611

A	Slimline optical drive bay
B	Hot Swap Hard Drive Bay

**Figure 7. Drive Bays - SR1530HCL/SR1530HCLR (SATA) and SR1530HCLS/SR1530HCLSR (SAS)**

## 1.6 Power Sub-System

The power sub-system consists of one non-redundant 400-watt power supply. It provides integrated management features, including over-temperature protection circuitry and over-voltage protection circuitry.

The power supply operates within the following voltage ranges and ratings:

Parameter	Minimum	Rated	Maximum	Start up VAC	Power Off VAC
Voltage (110)	90 Vrms	100-127 Vrms	140 Vrms	85Vac +/-4Vac	75Vac +/-5Vac
Voltage (220)	180 Vrms	200-240 Vrms	264 Vrms		
Frequency	47 Hz		63 Hz		

The power supply must operate within all specified limits over the input voltage ranges shown in the table. Harmonic distortion of up to 10% THD must not cause the power supply to exceed the specified limits.

The power supply shall power off if the AC input is less than 75 VAC +/- 5 VAC range. The power supply shall start up if the AC input is greater than 85 VAC +/- 4 VAC. Application of an input voltage below 85 VAC shall not cause damage to the power supply, including a fuse blow.

### 1.7 System Cooling

The system provides two non-redundant blower fans. The Intel® Server System SR1530CL/SR1530CLR (SATA) also includes an additional PCI cooling fan. When external ambient temperatures remain within specified limits, the cooling system will provide sufficient air flow for all drive configurations, processors, supported memory, and add-in cards.

### 1.8 Rack and Cabinet Mounting Options

The Intel® Server System SR1530CL/SR1530CLR (SATA) can be installed in 19-inch wide by up to 30-inch deep server cabinets. The system supports three rack mount options:

- A fixed mount relay rack / cabinet mount kit which can be configured to mount the system into either a 2-post or 4-post rack cabinet. (Product order code for the cabinet mount kit: AXXBRACKETS).
- A tool-less full extracting slide rail kit designed to support an optional cable management arm. (Product order code for the sliding rail kit: AXXHERAIL. Product order code for the cable management arm: AXXRACKCARM).
- A basic slide rail kit designed to mount the chassis into a standard 19-inch by up to 30-inch deep EIA-310D compatible server cabinet. (Product order code for the slide rail kit: AXXBASICRAIL).

## 2. Power Sub-System

This specification defines a 400-watt non-redundant power supply that supports a 1U rack mount server system. The power supply and the power supply sub-system shall have five outputs; 3.3 V, 5 V, 12 V, -12 V, and 5 VSB. The input shall be auto-ranging and power factor corrected. The form factor is SSI EPS1U at 300 mm depth and wire harness output.

The power supply provides two non-redundant 40 mm fans for self-cooling. The power supply fans also contribute to the airflow for parts of the system.

### 2.1 Mechanical Overview

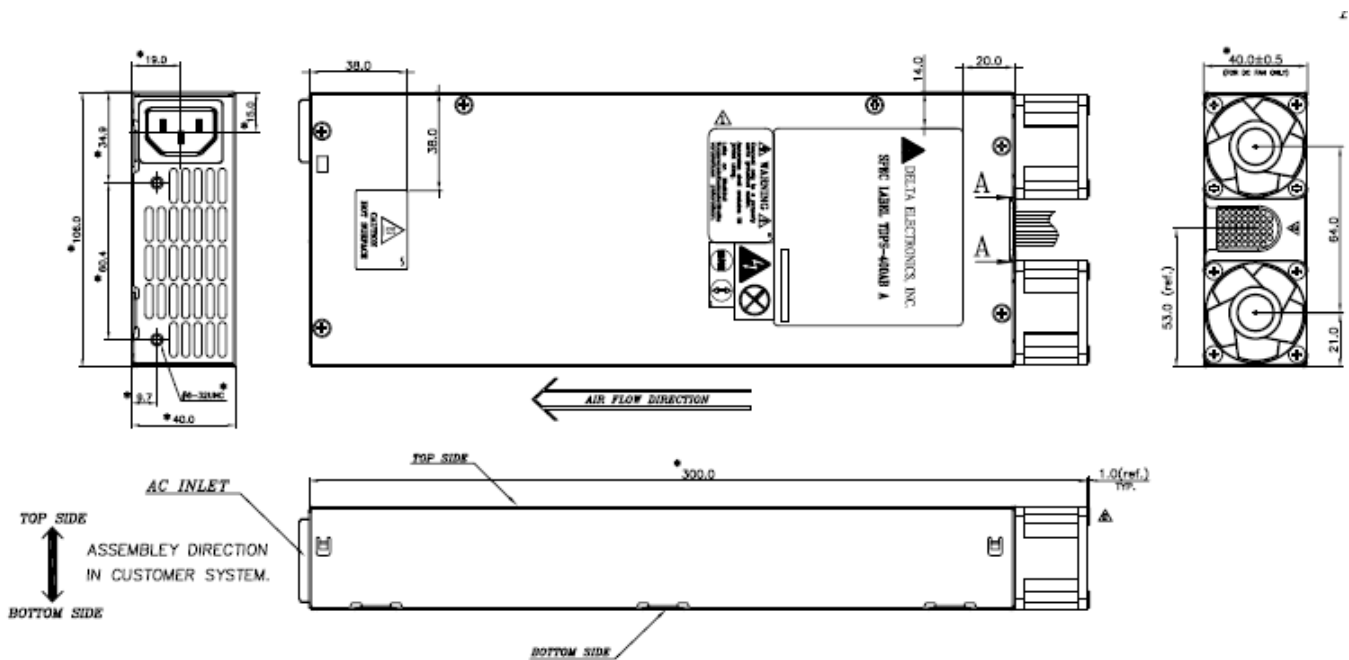

Figure 8. Power Supply Mechanical Drawing



## 2.2 Output Connectors

The power supply has a cable harness with five power connectors used to power various platform sub-systems. The following table defines each power connector.

**Table 3. Cable Harness Definition**

Label		Length (mm)	Description
P1			Main power connector
P2		440	Processor power connector
P3		400	Signal connector
P4,5,6		400+160+205	P4,5:SATA drive power connectors P6:CD connector
From	Length	To	Description
Case	400	P1	Main Power Connector
Case	340	P2	Processor Power Connector
Case	410	P3	Signal Connector
Case	220	P7	2x3 HSBP power connector
P7	100 +145+170	P4,P5,P6	P4,5:SATA drive power connectors P6:CD connector

### 2.2.1 P1 – Main Power Connector

- Connector housing: 24-pin Molex\* Mini-Fit Jr. 39-01-2245 (94V2) or equivalent
- Contact: Molex Mini-Fit, HCS, Female, Crimp 44476 or equivalent

**Table 4. P1 – Main Power Connector Pin-out**

Pin	Signal	18 Awg Color	Pin	Signal	18 Awg Color
1	+3.3 VDC	Orange	13	+3.3 VDC	Orange
2	+3.3 VDC	Orange	14	-12 VDC	Blue
3	COM	Black	15	COM	Black
4	+5 VDC <sup>1</sup>	Red	16	PSON#	Green
5	COM	Black	17	COM	Black
6	+5 VDC	Red	18	COM	Black
7	COM	Black	19	COM	Black
8	PWR OK	Gray	20	Reserved	N.C.
9	5VSB	Purple	21	+5 VDC	Red
10	+12V	Yellow	22	+5 VDC	Red
11	+12V	Yellow	23	+5 VDC	Red
12	+3.3 VDC	Orange	24	COM	Black

**Notes:**

1. 5V Remote Sense double-crimped into pin 4.

### 2.2.2 P2 – Processor Power Connector

- Connector housing: 8-pin Molex\* 39-01-2085 (94V2) or equivalent
- Contact: Molex, Mini-Fit Jr, HCS, 44476-1111 or equivalent

**Table 5. P2 – Processor Power Connector Pin-out**

Pin	Signal	18 Awg Color	Pin	Signal	18 Awg Color
1	COM	Black	5	+12V	Yellow
2	COM	Black	6	+12V	Yellow
3	COM	Black	7	+12V	Yellow
4	COM	Black	8	+12V	Yellow

### 2.2.3 P3 – Baseboard Signal Connector

- Connector housing: 5-pin Molex\* 50-57-9705 (94V2) or equivalent
- Contacts: Molex 16-02-0087 or equivalent

**Table 6. P3 – Baseboard Signal Connector Pin-out**

Pin	Signal	24 Awg Color
1	I2C Clock	White/Green Stripe
2	I2C Data	White/Yellow Stripe
3	Reserved	NC
4	COM	Black
5	3.3RS	White/Brown Stripe

### 2.2.4 P4 and P5 – SATA Hard Drive Power Connectors

- Connector housing: JWT\* A3811H00-5P (94V2) or equivalent
- Contact: JWT A3811TOP-0D or equivalent

**Table 7. P4 and P5 – SATA Hard Drive Power Connector Pin-out**

Pin	Signal	18 Awg Color
1	+3.3V	Orange
2	COM	Black
3	+5VDC	Red
4	COM	Black
5	+12V	Yellow

### 2.2.5 P6 – CD Power Connector

- Connector housing: Molex\* 51065-0400 (94V2) or equivalent
- Contact: Molex 50212-8000 contact or equivalent

**Table 8. P6 – CD Power Connector Pin-out**

Pin	Signal	22 Awg Color
1	+5VDC	Red
2	COM	Black
3	COM	Black
4	+12V	Yellow

### 2.2.6 P7 – HSBP Power Connector

- Connector housing: 8-pin Molex\* 39-01-2085 (94V2) or equivalent
- Contact: Molex 2x4 Mini Fit Jr, HCS, 44476-3111 contact or equivalent

**Table 9. P7 – CD Power Connector Pin-out**

Pin	Signal	18 Awg Color	Pin	Signal	18 Awg Color
1	GND	Black	5	+12V	Blue/White Stripe
2	GND	Black	6	NC	
3	+5V	Red	7	NC	
4	NC		8	3.3V	Orange

## 2.3 Efficiency

The following table provides the required minimum efficiency level at various loading conditions. These are provided at three different load levels; 100%, 50% and 20%. Efficiency shall be tested over an AC input voltage range of 115 VAC to 220 VAC.

**Table 10. Power Supply Efficiency**

Loading	100% of Maximum	50% of Maximum	20% of Maximum
Minimum Efficiency	72%	70%	60%

## 2.4 AC Input Voltage Requirement

The power supply must operate within all specified limits over the following input voltage range, shown in below table. Harmonic distortion of up to 10% THD must not cause the power supply to go out of specified limits. The power supply shall power off if the AC input is less than 75 VAC +/- 5 VAC range. The power supply shall start up if the AC input is greater than 85 VAC +/-

4 VAC. Application of an input voltage below 85 VAC shall not cause damage to the power supply, including a fuse blow.

**Table 11. AC Input Rating**

Parameter	Minimum	Rated	Maximum	Start up VAC	Power Off VAC
Voltage (110)	90 V <sub>rms</sub>	100-127 V <sub>rms</sub>	140 V <sub>rms</sub>	85Vac +/-4Vac	75VAC +/-5VAC
Voltage (220)	180 V <sub>rms</sub>	200-240 V <sub>rms</sub>	264 V <sub>rms</sub>		
Frequency	47 Hz		63 Hz		

## 2.5 Protection Circuits

Protection circuits inside the power supply shall cause only the power supply's main outputs to shut down. If the power supply latches off due to a protection circuit tripping, an AC cycle off for 15 seconds and a PSON<sup>#</sup> cycle high for 1 second shall be able to reset the power supply.

### 2.5.1 Over-current Protection (OCP)

The power supply shall have current limit to prevent the +3.3 V, +5 V, and +12 V outputs from exceeding the values shown in the following table. If the current limits are exceeded the power supply shall shutdown and latch off. The latch will be cleared by toggling the PSON<sup>#</sup> signal or by an AC power interruption. The power supply shall not be damaged from repeated power cycling in this condition. -12 V and 5 VSB shall be protected under over-current or shorted conditions so that no damage can occur to the power supply. Auto-recovery feature is a requirement on 5 VSB rail.

**Table 12. Over-current Protection (OCP)**

Voltage	Over-current Limit (I <sub>out</sub> limit)
+3.3V	110% minimum (= 16.5A) ; 150% maximum (= 22.5A)
+5V	110% min (= 11.0A); 150% max (= 15.0A)
+12V	39.6A min; 54.0A max
-12V	0.625A min; 2.0A max
5VSB	6.0A max

### 2.5.2 Over-voltage Protection (OVP)

The power supply over-voltage protection shall be locally sensed. The power supply shall shut down and latch off after an over-voltage condition occurs. This latch shall be cleared by toggling the PSON<sup>#</sup> signal or by an AC power interruption. The following table contains the over-voltage limits. The values are measured at the output of the power supply's connectors. The voltage shall never exceed the maximum levels when measured at the power pins of the power supply connector during any single point of fail. The voltage shall never trip any lower than the minimum levels when measured at the power pins of the power supply connector.

## Power Sub-System

Exception: +5VSB rail should be able to recover after an over-voltage condition occurs.

**Table 13. Over-Voltage Protection (OVP) Limits**

Output Voltage	Minimum (V)	Maximum (V)
+3.3 V	3.9	4.5
+5 V	5.7	6.2
+12 V	13.3	14.5
-12 V	-13.3	-14.5
+5 VSB	5.7	6.5

### 2.5.3 Over-temperature Protection (OTP)

The power supply will be protected against over temperature conditions caused by loss of fan cooling or excessive ambient temperature. In an OTP condition the power supply will shut down. When the power supply temperature drops to within specified limits, the power supply shall automatically restore power, while the 5 VSB remains always on. The OTP circuit must have built in hysteresis such that the power supply will not oscillate on and off due to temperature recovering condition. The OTP trip level shall have a minimum of 4°C of ambient temperature hysteresis.

## 2.6 AC Power Cord Specification Requirements

The AC power cord must meet the following specification requirements:

Cable Type	SJT
Wire size	16 AWG
Temperature rating	105° C
Amperage rating	13 A
Voltage rating	125 V

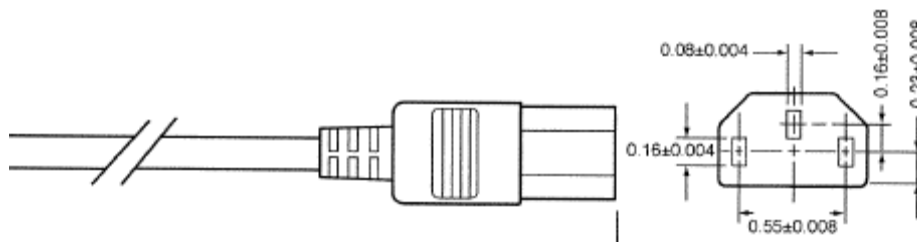

### 3. Cooling Sub-System

---

The cooling sub-system consists of two 97 x 94 x 33 blower fan, a CPU air duct, and a PS / electronics bay isolation air baffle. The SR1530CL also includes one additional 40 x 40 x 15 PCI cooling fan. These components are used to provide the necessary cooling and airflow to the system. A fan on the processor heat sink is not needed.

To maintain the necessary airflow within the system, the air duct and the top cover must be properly installed.

---

**Note:** The Intel® Server Systems SR1530CL/SR1530HCL/SR1530HCLS and SR1530CLR/SR1530HCLR/SR1530HCLSR do not support redundant cooling. Should a fan blower fail, the system should be powered down as soon as possible to replace the failed fan blower.

---

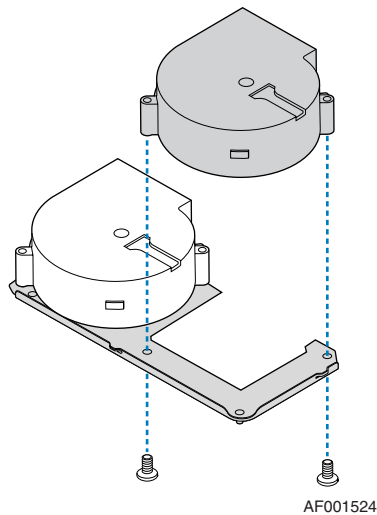

**Figure 9. Fan Module Assembly - SR1530CL/SR1530CLR (SATA)**

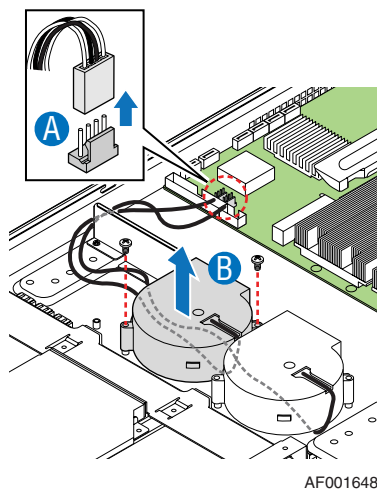

**Figure 10. Fan Module Assembly - SR1530HCL/SR1530HCLR (SATA) and SR1530HCLS/SR1530HCLSR (SAS)**

**Table 14. Cooling Zones**

Fan	Cooling Zone	Greatest Cooling Influence
System fan blower 1	CPU1	Primary cooling for CPU1 and the system memory
System fan blower 2	CPU2	Primary cooling for hard HDD1, CPU2, the MCH, and the low-profile PCI cards
PCI cooling fan (SR1530CL only)	PCI	Primary cooling for HDD0, full-height PCI cards, PXH and the IOP80333 chipset

### 3.1 Power Supply Fans

The power supply supports two non-redundant 40 mm fans. They are responsible for the cooling of the power supply, first hard drive bay, and slimline drive bay.

### 3.2 Processor Air Duct and Air Baffle

The system requires the use of a processor air duct and power supply / electronics bay isolation air baffle to direct airflow and sustain appropriate air pressure.

An air baffle isolates the air flow of the two power supply fans from that of the system fan module. The baffle is mounted into three stand-offs with one end fitting under the back edge of the hard drive bay.

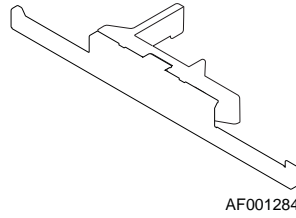

**Figure 11. Air Baffle (SR1530CL/SR1530CLR)**

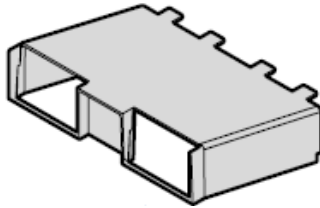
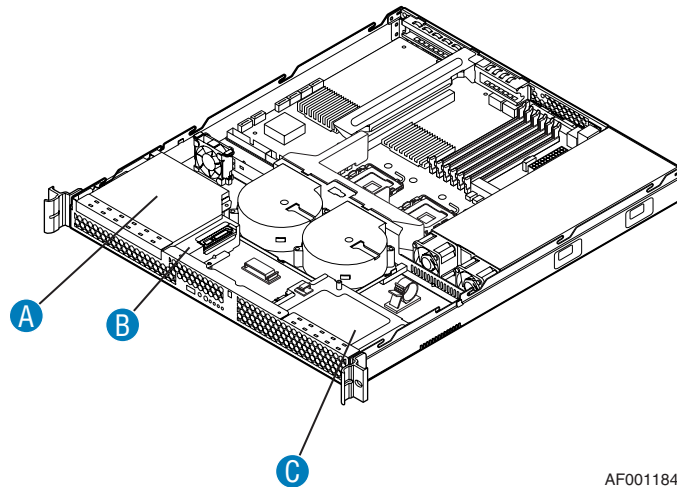

**Figure 12. Air Baffle (SR1530HCL/SR1530HCLR)**



## 4. Peripheral and Hard Drive Support

The Intel® Server System SR1530CL/SR1530CLR (SATA) provides support for two fixed hard drive bays and one slimline peripheral drive bay at the front of the system. The fixed hard drive bays are designed to support SATA drives.



AF001184

A	Slimline optical drive bay
B	Hard drive bay HDD0 (located under the slimline optical drive bay)
C	Hard drive bay HDD1

**Figure 13. Drive Bays SR1530CL/SR1530CLR (SATA)**

The Intel® Server Systems SR1530HCL/SR1530HCLR (SATA) and SR1530HCLS/SR1530HCLSR (SAS) provides support for three hot-swap hard drive bays and one slimline peripheral drive bay at the front of the system. The fixed hard drive bays are designed to support SATA drives.

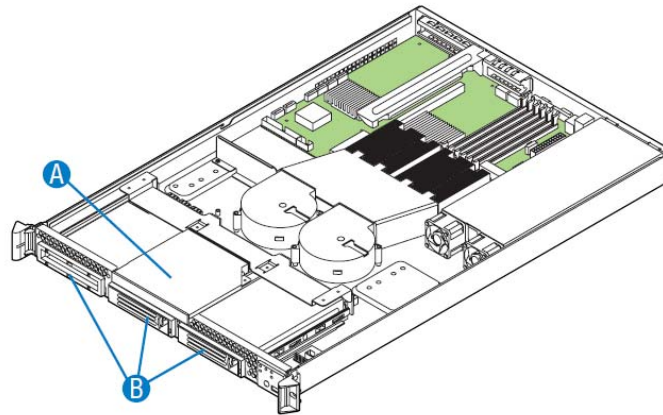

AF001611

**Figure 14. Drive Bays - SR1530HCL/SR1530HCLR (SATA) and SR1530HCLS/SR1530HCLSR (SAS)**

A	Slimline optical drive bay
B	Hot Swap Hard drive bay

## 4.1 Optical Drive Support

The system provides a slimline drive bay that can be configured for an IDE optical CD-ROM, or a DVD / CDR drive. Drives are mounted on a tool-less tray which allows for easy installation into and removal from the system. The slimline devices are not hot-swappable.

### 4.1.1 Optical Drive Support

The systems support a slimline IDE optical drive. The drive is mounted onto a tool-less drive tray and is connected to an interposer card attached to the tray. The drive assembly is then inserted in to the slimline drive bay. A 44-pin ribbon cable is used to connect the drive assembly to a matching IDE connector on the server board.

Table 15. 44-pin Internal IDE Connector Pin-out

Pin	Signal Name	Pin	Signal Name
1	ESB_PLT_RST_IDE_N	2	GND
3	RIDE_DD_7	4	RIDE_DD_8
5	RIDE_DD_6	6	RIDE_DD_9
7	RIDE_DD_5	8	RIDE_DD_10
9	RIDE_DD_4	10	RIDE_DD_11
11	RIDE_DD_3	12	RIDE_DD_12
13	RIDE_DD_2	14	RIDE_DD_13
15	RIDE_DD_1	16	RIDE_DD_14
17	RIDE_DD_0	18	RIDE_DD_15
19	GND	20	KEY
21	RIDE_DDREQ	22	GND
23	RIDE_DIOW_N	24	GND
25	RIDE_DIOR_N	26	GND
27	RIDE_PIORDY	28	GND
29	RIDE_DDACK_N	30	GND
31	IRQ_IDE	32	TP_PIDE_32
33	RIDE_DA1	34	IDE_PRI_CBLSNS
35	RIDE_DA0	36	RIDE_DA2
37	RIDE_DCS1_N	38	RIDE_DCS3_N
39	LED_IDE_N	40	GND
41	P5V	42	P5V
43	GND	44	GND

## 4.2 Hard Disk Drive Support

The Intel® Server System SR1530CL/SR1530CLR (SATA) can support up to two 3.5-inch by 1-inch fixed SATA hard disk drives. The drives are mounted inside the systems. The Intel® Server System SR1530HCL/SR1530HCLR (SATA) can support up to three SATA hot-swap hard disk drives. The Intel® Server System SR1530HCLS/SR1530HCLSR (SAS) can support up to three SATA or three SAS hard disk drives.

### 4.2.1 Hot-Swap Hard Disk Drive Trays

Each hard drive must be mounted to a hot-swap drive tray, making insertion and extraction of the drive from the system very simple. Each drive tray has its own dual purpose latching mechanism which is used to both insert and extract drives from the system and lock the tray in place. Each drive tray supports a light pipe providing a drive status indicator, located on the backplane, to be viewable from the front of the system.

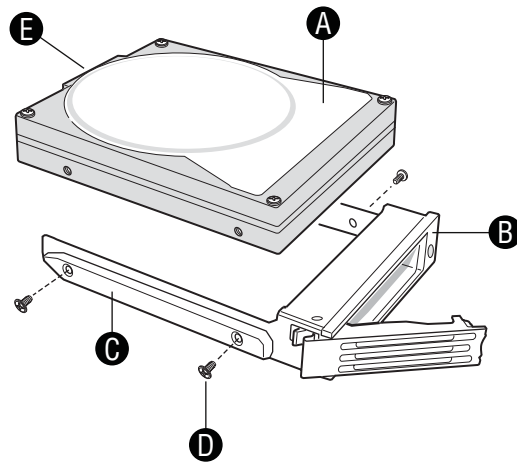

TP02170

**Figure 15. Hard Drive Tray Assembly**

- A. Hard Drive
- B. Drive Carrier
- C. Side Rail
- D. Mounting Screw
- E. Hard Drive Connector

#### 4.2.2 Drive Blanks

Drive blanks must be used when no drive is used in a hard drive bay. Drive blanks simulate the spatial volume of a hard disk which is required to maintain proper air pressure limits necessary to cool the system.

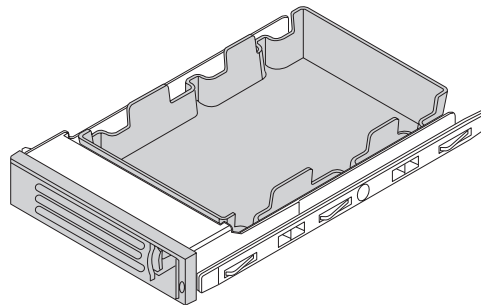

TP02104

**Figure 16. Drive Tray with Drive Blank**

### 4.2.3 System Fan Connectors

The Intel® Server System SR1530CL/SR1530CLR (SATA) supports two system fan blowers and one PCI cooling fan. The pin-out for each connector is provided in the following table. The Intel® Server Systems SR1530HCL/SR1530HCLR and SR1530HCLS/SR1530HCLSR support two system fan blowers.

**Table 16. System Fan Connector Pin-outs**

J1K1 – PCI_FAN		J2K3 - CPU1_FAN		J2K4 - CPU2_FAN	
Pin	Signal Name	Pin	Signal Name	Pin	Signal Name
1	GND	1	GND	1	
2	P12V	2	P12V	2	
3	PCI_Fan_Tach9_R	3	FAN_TACH1_H7_R	3	FAN_TACH3_H7
		4	FAN_PWM_CPU1	4	FAN_PWM_CPU2

## 5. Front Control Panel

The standard control panel supports a power and reset buttons, status LED, hard drive activity LED, and NIC 1 and NIC 2 activity LEDs. The control panel assembly comes pre-assembled into the system. The control panel assembly module slides into a predefined slot on the front of the system. Once installed, communication to the server board can be achieved through a standard 24-pin cable connected directly to the server board.

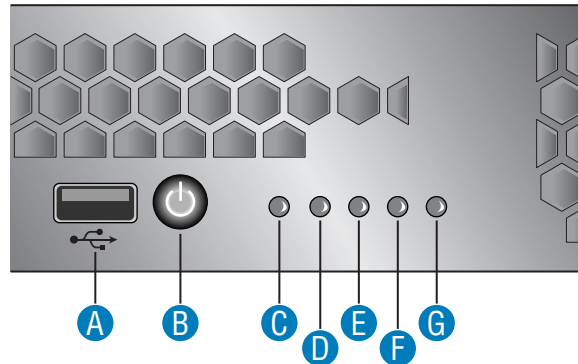

AF001000

Item	Feature
A	USB port
B	Power button. This button also functions as a sleep button if enabled by an ACPI-compliant operating system.
C	Status LED
D	System power LED
E	Hard drive activity LED
F	NIC 1 LED
G	NIC 2 LED

**Figure 17. Front Control Panel - SR1530CL/SR1530CLR (SATA)**

## Front Control Panel

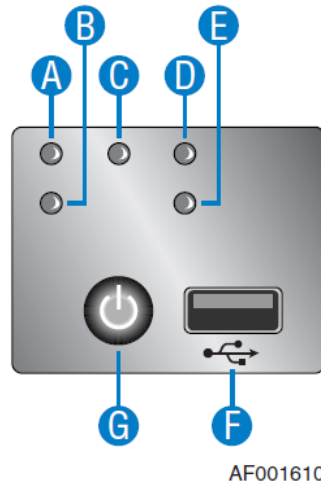

AF001610

**Figure 18. Front Control Panel - SR1530HCL/SR1530HCLR (SATA) and SR1530HCLS/SR1530HCLSR (SAS)**

Item	Feature
A	NIC 1 LED
B	NIC 2 LED
C	System power LED
D	System power LED
E	Hard drive activity LED
F	Hard drive activity LED
G	Power button. This button also functions as a sleep button if enabled by an ACPI-compliant operating system.

**Table 17. Control Panel LED Functions**

LED	Color	State	Description
NIC1 / NIC2 Activity	Green	On	NIC Link/no access
	Green	Blink	LAN access
Power / Sleep (on standby power)	Green	On	Power on
		Blink	Sleep / ACPI S1 state
	Off	Off	Power Off / ACPI S4 state
System Status (on standby power)	Green	On	Running / normal operation
		Blink	System ready, but degraded
	Amber	On	Critical or non-recoverable condition. Possible critical power module failure, critical fan failure, voltage (power supply), voltage and thermal fault
		Blink	Non-critical condition.
	Off	Off	POST / system stop. System not ready
Disk Activity	Green	Random blink	HDD access
	Off	Off	No hard disk activity

The current limiting resistors for the power LED, the system fault LED, and the NIC LEDs are located on the Intel® Server Board S5000VCL.

### 5.1.1 Power / Sleep LED

**Table 18. SSI Power LED Operation**

State	Power Mode	LED	Description
Power Off	Non-ACPI	Off	System power is off, and the BIOS has not initialized the chipset.
Power On	Non-ACPI	On	System power is on, but the BIOS has not yet initialized the chipset.
S5	ACPI	Off	Mechanical is off, and the operating system has not saved any context to the hard disk.
S4	ACPI	Off	Mechanical is off. The operating system has saved context to the hard disk.
S3-S1	ACPI	Slow blink <sup>1</sup>	DC power is still on. The operating system has saved context and gone into a level of low-power state.
S0	ACPI	Steady on	System and the operating system are up and running.

**Note:**

1. The blink rate is ~ 1Hz with at 50% duty cycle.

### 5.1.2 System Status LED

**Table 19. Control Panel LED Operation**

Color	State	Criticality	Description
Off	N/A	Not ready	System not ready: Post error/NMI event/PCI or terminator missing
Green	Solid on	Ok	System booted and ready
Green	Blink	Degraded	System degraded <ul style="list-style-type: none"> <li>▪ Unable to use all of the installed memory (more than one DIMM installed).</li> <li>▪ Correctable errors over a threshold of 10 and migrating to a spare DIMM (memory sparing). This indicates that the user no longer has spared DIMMs indicating a redundancy lost condition. Corresponding DIMM LED should light up.</li> <li>▪ In mirrored configuration, when memory mirroring takes place and system loses memory redundancy.</li> <li>▪ Redundancy loss such as power-supply or fan. This does not apply to non-redundant sub-systems.</li> <li>▪ PCI-e link errors</li> <li>▪ CPU failure / disabled – if there are two processors and one of them fails</li> <li>▪ Fan alarm – Fan failure. Number of operational fans should be more than minimum number needed to cool the system</li> <li>▪ Non-critical threshold crossed – Temperature and voltage</li> </ul>



## Front Control Panel

Amber	Blink	Non-critical	Non-fatal alarm – system is likely to fail <ul style="list-style-type: none"><li>▪ Critical voltage threshold crossed</li><li>▪ VRD hot asserted</li><li>▪ Minimum number of fans to cool the system not present or failed</li><li>▪ In non-sparing and non-mirroring mode if the threshold of ten correctable errors is crossed within the window</li></ul>
Amber	Solid on	Critical, non-recoverable	Fatal alarm – system has failed or shutdown <ul style="list-style-type: none"><li>▪ DIMM failure when there is one DIMM present, no good memory present</li><li>▪ Run-time memory uncorrectable error in non-redundant mode</li><li>▪ IERR signal asserted</li><li>▪ Processor 1 missing</li><li>▪ Temperature (CPU ThermTrip, memory TempHi, critical threshold crossed)</li><li>▪ No power good – power fault</li><li>▪ Processor configuration error (for instance, processor stepping mismatch)</li></ul>

### 5.1.3 Drive Activity LED

The drive activity LED on the front panel indicates drive activity from the onboard hard disk controllers. The Intel® Server Board S5000VCL also provides a header giving access to this LED for add-in controllers.

## 6. PCI Riser Cards and Assembly

---

The Intel® Server Board S5000VCL provides one PCI super slot which supports one riser card with two riser card slots.

- One low-profile (68.9mm X 119.91mm) PCI Express\* x8 and one full height/mid length(106.68mm x 241.3mm) PCI-X\* 133
- Or one low-profile (68.9mm X 119.91mm) PCI Express\* x4 and one full height/mid-length (106.68mm x 241.3mm) PCI Express\* x4.

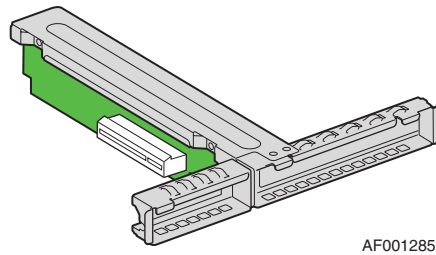

**Figure 19. PCI Riser Card Assembly**

## 7. Backplane Board

---

The Intel® Server Systems SR1530HCL/SR1530HCLR (SATA) and SR1530HCLS/SR1530HCLSR (SAS) supports a passive backplane designed to be compatible with the Intel® Server Board S5000VCL. The Intel® Server Board S5000VCL is connected directly to the SATA/SAS backplane (default) or the backplane may be connected to an add-in SAS or SATA adapter.

The system supports a multifunctional SATA/SAS backplane with the following features:

- Three SATA/SAS compatible hot-swap hard drive connectors.
- Three SATA/SAS connectors to the baseboard.
- Hard Drive Activity LED for each hard drive connector.
- One 2x4-pin power connector.

The Intel® Server Board SC000VCL on-board SATA/SAS controller will support the following RAID Arrays:

- Intel® Embedded Server RAID Technology - RAID 0, RAID 1, or RAID 10

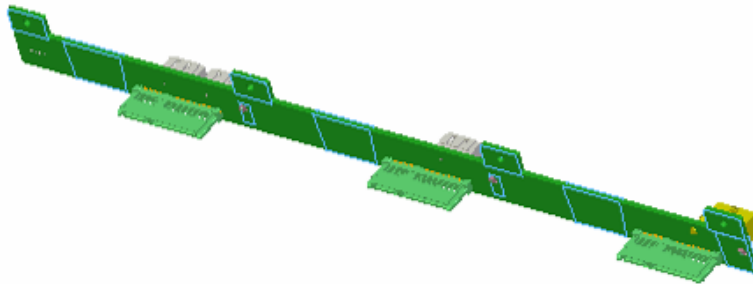

**Figure 20. Hot Swap Passive Backplane - SR1530HCL/SR1530HCLR (SATA) and SR1530HCLS/SR1530HCLSR (SAS)**

**Table 20. Passive SATA/SAS Backplane Power Connector Pin-out (J7)**

Pin #	Signal Name
1	Ground
2	Ground
3	P5V
4	P5V
5	P12V
6	P12V
7	No Connection
8	P3V3

Table 21. Passive SATA/SAS Backplane Connector to Hard Drive Pin-out (J1, J2, J3)

Pin #	Signal Name
S1	Ground
S2	SAS_DRVxA_RX_P
S3	SAS_DRVxA_RX_N
S4	Ground
S5	SAS_DRVxA_TX_N
S6	SAS_DRVxA_TX_P
S7	Ground
P1	TP
P2	TP
P3	TP
P4	Ground
P5	Ground
P6	Ground
P7	P5V_DRVx_PRECHG
P8	P5V
P9	P5V
P10	Ground
P11	LED_DRVx_READY_N
P12	Ground
P13	P12V_DRVx_PRECHG
P14	P12V
P15	P12V

Table 22. Passive SATA/SAS Backplane I/O Connector to Baseboard Pin-out (J4, J5, J6)

Pin #	Signal Name
1	Ground
2	SASx_EP_RX_P
3	SASX_EP_RX_N
4	Ground
5	SASx_EP_TX_N
6	SASx_EP_TX_P
7	Ground

## Backplane Board

### 7.1.1 Hard Drive Activity LED

The drive activity LED on the hard drive carrier for the Intel® Server Systems SR1530HCL/SR1530HCLR (SATA) and SR1530HCLS/SR1530HCLSR (SAS) shows the following status.

For SAS Drives:

Status	LED Color	Description
Good Drive	Solid Green	LED will stay a solid green color during good drive activity. If there is no activity the LED will be off.
Failed Drive	Solid Light Orange	During a drive failure the LED will go from solid green to solid orange.
Drive during Rebuild	Blinking Light Orange	During a drive rebuild the drive LED will go from a solid orange to a blinking orange. Once the rebuild is complete the LED will turn off.

For SATA II Drives:

Status	LED Color	Description
Good Drive	Solid Green	LED will stay a solid green color during good drive activity. If there is no activity the LED will be off.
Failed Drive	Dark Orange	During a drive failure the LED will go from solid green to solid dark orange.
Drive during Rebuild	Light Orange	During a drive rebuild the drive LED will go from a solid dark orange to a light orange. Once the rebuild is complete the LED will turn off.

For SATA I Drives:

<b>Status</b>	<b>LED Color</b>	<b>Description</b>
Good Drive	Solid Green	LED will stay a solid green color during good drive activity. If there is no activity the LED will be off.
Failed Drive	Solid Orange	During a drive failure the LED will go from solid green to solid orange.
Drive during Rebuild	Solid Orange	During a drive rebuild the drive LED will stay solid orange until the rebuild is complete. Once the rebuild is complete the LED will turn off.

## 8. Supported Intel® Server Boards

The systems are mechanically and functionally designed to support the Intel® Server Board S5000VCL. See the technical product specification for the server board for detailed server board information.

### 8.1 Intel® Server Board S5000VCL Feature Set

Feature	Description
Processors	771-pin LGA sockets supporting one or two Dual-Core Intel® Xeon® processors 5100 series and low-voltage Quad-Core® Xeon® processors 5300 series, with system bus speeds of 1066 MHz or 1333 MHz For a complete list of supported processors, see the following link: <a href="http://support.intel.com/support/motherboards/server/S5000VCL">http://support.intel.com/support/motherboards/server/S5000VCL</a>
Memory	Six keyed DIMM slots supporting fully buffered DIMM technology (FBDIMM) memory. 240-pin DDR2-677 FBDIMMs must be used.
Chipset	Intel® 5000V Chipset Family which includes the following components: <ul style="list-style-type: none"> <li>▪ Intel® 5000V Memory Controller Hub</li> <li>▪ Intel® 6321ESB I/O Controller Hub</li> </ul>
On-board Connectors / Headers	External connections: <ul style="list-style-type: none"> <li>▪ Stacked PS/2* ports for keyboard and mouse</li> <li>▪ Two RJ45 NIC connectors for 10/100/1000 Mb connections</li> <li>▪ Two USB 2.0 ports</li> <li>▪ Video connector</li> <li>▪ Com 1 or Serial A (DB9)</li> </ul> Internal connectors/headers: <ul style="list-style-type: none"> <li>▪ One USB port header, capable of providing two USB 2.0 ports</li> <li>▪ One DH10 Serial B header</li> <li>▪ Six SATA ports or four SAS ports via the Intel® 6321ESB I/O Controller Hub. These ports support 3Gb/s and integrated SW RAID 0 or 1</li> <li>▪ One 40-pin (power + I/O) ATA/100 connector for optical drive support</li> <li>▪ SSI-compliant 24-pin control panel header</li> <li>▪ SSI-compliant 24-pin main power connector, supporting the ATX-12 V standard on the first 20 pins</li> <li>▪ 8-pin +12 V processor power connector</li> </ul>
Add-in PCI, PCI-X*, PCI Express* Cards	One PCI super-slot that will support one 1U riser card with one PCI-X* and one PCI Express* connectors
On-board Video	ATI* ES1000 video controller with 16 MB DDR SDRAM
On-board Hard Drive Controller	Six 3 Gb/s SATA ports, or four SAS ports Intel® Embedded Server RAID Technology II with RAID levels 0, 1, 10
LAN	Two 10/100/1000 NICs supporting Intel® I/O Acceleration Technology
System Fans	Two CPU 4-pin fan headers supporting two system blowers and one 3-pin fan header supporting a system fan
System Management	Support for Intel® System Management Software

## 9. Environmental and Regulatory Specifications

### 9.1 System Level Environmental Limits

The table below defines the system level operating and non-operating environmental limits

**Table 23. System Environmental Limits Summary**

Parameter	Limits
Operating Temperature	+10°C to +35°C with the maximum rate of change not to exceed 10°C per hour
Non-Operating Temperature	-40°C to +70°C
Non-Operating Humidity	90%, non-condensing at 35°C
Acoustic noise	Sound power: 7.0 BA in an idle state at typical office ambient temperature. (23 +/- 2 degrees C)
Shock, operating	Half sine, 2 g peak, 11 mSec
Shock, unpackaged	Trapezoidal, 25 g, velocity change 136 inches/sec ( $\geq 40$ lbs to $> 80$ lbs)
Shock, packaged	Non-palletized free fall in height 24 inches ( $\geq 40$ lbs to $> 80$ lbs)
Vibration, unpackaged	5 Hz to 500 Hz, 2.20 g RMS random
Shock, operating	Half sine, 2 g peak, 11 mSec
ESD	+/-15kV except I/O port +/-8KV per Intel Environmental test specification
System Cooling Requirement in BTU/Hr	2550 BTU/hour

### 9.2 Serviceability and Availability

The system is designed to be serviced by qualified technical personnel only.

The desired Mean Time To Repair (MTTR) of the system is 30 minutes including diagnosis of the system problem. To meet this goal, the system enclosure and hardware have been designed to minimize the MTTR.

Following are the maximum times that a trained field service technician should take to perform the listed system maintenance procedures, after diagnosis of the system and having identified the failed component.

Activity	Time Estimate
Remove cover	1 min
Remove and replace hard disk drive	5 min
Remove and replace power supply module	1 min
Remove and replace system fan	7 min
Remove and replace control panel module	2 min
Remove and replace baseboard	15 min



### 9.3 Replacing the CMOS Battery

The lithium battery on the server board powers the real time clock (RTC) for several years in the absence of power. When the battery starts to weaken, it loses voltage, and the server settings stored in CMOS RAM in the RTC (for example, the date and time) may be wrong. Contact your customer service representative or dealer for a list of approved devices.



#### WARNING

---

**Danger of explosion if battery is incorrectly replaced. Replace only with the same or equivalent type recommended by the equipment manufacturer. Discard used batteries according to manufacturer's instructions.**



#### ADVARSEL!

---

**Lithiumbatteri - Eksplosjonsfare ved feilagtig håndtering. Utskiftning må kun ske med batteri af samme fabrikat og type. Levér det brugte batteri tilbage til leverandøren.**



#### ADVARSEL

---

**Lithiumbatteri - Eksplosjonsfare. Ved utskifting benyttes kun batteri som anbefalt av apparatfabrikanten. Brukt batteri returneres apparatleverandøren.**



#### WARNING

---

**Explosionsfara vid felaktigt batteribyte. Använd samma batterityp eller en ekvivalent typ som rekommenderas av apparattillverkaren. Kassera använt batteri enligt fabrikantens instruktion.**



#### VAROITUS

---

**Paristo voi räjähtää, jos se on virheellisesti asennettu. Vaihda paristo ainoastaan laitevalmistajan suosittelemaan tyyppiin. Hävitä käytetty paristo valmistajan ohjeiden mukaisesti.**

## 9.4 Product Regulatory Compliance

The server chassis product, when correctly integrated per this guide, complies with the following safety and electromagnetic compatibility (EMC) regulations.

**Intended Application** – This product was evaluated as Information Technology Equipment (ITE), which may be installed in offices, schools, computer rooms, and similar commercial type locations. The suitability of this product for other product categories and environments (such as: medical, industrial, telecommunications, NEBS, residential, alarm systems, test equipment, etc.), other than an ITE application, may require further evaluation.

### Notifications to Users on Product Regulatory Compliance and Maintaining Compliance

To ensure regulatory compliance, you must adhere to the assembly instructions in this guide to ensure and maintain compliance with existing product certifications and approvals. Use only the described, regulated components specified in this guide. Use of other products / components will void the UL listing and other regulatory approvals of the product and will most likely result in noncompliance with product regulations in the region(s) in which the product is sold.

To help ensure EMC compliance with your local regional rules and regulations, before computer integration, make sure that the chassis, power supply, and other modules have passed EMC testing using a server board with a microprocessor from the same family (or higher) and operating at the same (or higher) speed as the microprocessor used on this server board. The final configuration of your end system product may require additional EMC compliance testing. For more information please contact your local Intel Representative. This is an FCC Class A device and its use is intended for a commercial type market place.

## 9.5 Use of Specified Regulated Components

To maintain the UL listing and compliance to other regulatory certifications and/or declarations, the following regulated components must be used and conditions adhered to. Interchanging or use of other component will void the UL listing and other product certifications and approvals. Updated product information for configurations can be found on the Intel Server Builder Web site at the following URL:

<http://channel.intel.com/go/serverbuilder>

If you do not have access to Intel's Web address, please contact your local Intel representative.

**Server chassis** (base chassis is provided with power supply and fans)—UL listed.

**Server board**—you must use an Intel server board—UL recognized.

**Add-in boards**—must have a printed wiring board flammability rating of minimum UL94V-1. Add-in boards containing external power connectors and/or lithium batteries must be UL recognized or UL listed. Any add-in board containing modem telecommunication circuitry must be UL listed. In addition, the modem must have the appropriate telecommunications, safety, and EMC approvals for the region in which it is sold.





**Peripheral Storage Devices** - must be UL recognized or UL listed accessory and TUV or VDE licensed. Maximum power rating of any one device or combination of devices can not exceed manufacturers specifications. Total server configuration is not to exceed the maximum loading conditions of the power supply.



## Environmental and Regulatory Specifications

The following table references Server Chassis Compliance and markings that may appear on the product. Markings below are typical markings however, may vary or be different based on how certification is obtained.

Note: Certifications Emissions requirements are to Class A

**Table 24. Product Safety & Electromagnetic (EMC) Compliance**

Compliance Regional Description	Compliance Reference	Compliance Reference Marking Example
Australia / New Zealand	AS/NZS 3548 (Emissions)	 N232
Argentina	IRAM Certification (Safety)	
Belarus	Belarus Certification	None Required
Canada / USA	CSA 60950 – UL 60950 (Safety)	
	Industry Canada ICES-003 (Emissions)	CANADA ICES-003 CLASS A CANADA NMB-003 CLASSE A
	FCC CFR 47, Part 15 (Emissions)	This device complies with Part 15 of the FCC Rules. Operation of this device is subject to the following two conditions: (1) This device may not cause harmful interference, and (2) This device must accept interference receive, including interference that may cause undesired operation.
China	CNCA – CB4943 (Safety) GB 9254 (Emissions) GB17625 (Harmonics)	
CENELEC Europe	Low Voltage Directive 93/68/EEC; EMC Directive 89/336/EEC EN55022 (Emissions) EN55024 (Immunity) EN61000-3-2 (Harmonics) EN61000-3-3 (Voltage Flicker) CE Declaration of Conformity	
Germany	GS Certification – EN60950	
International	CB Certification – IEC60950 CISPR 22 / CISPR 24	None Required

Compliance Regional Description	Compliance Reference	Compliance Reference Marking Example
Japan	VCCI Certification	この装置は、クラス A 情報技術装置です。この装置を家庭環境で使用すると電波妨害を引き起こすことがあります。この場合には使用者が適切な対策を講ずるよう要求されることがあります。VCCI-A
Korea	RRL Certification MIC Notice No. 1997-41 (EMC) & 1997-42 (EMI)	 인증번호: CPU-Model Name (A)
Russia	GOST-R Certification GOST R 29216-91 (Emissions) GOST R 50628-95 (Immunity)	
Ukraine	Ukraine Certification	None Required
Taiwan	BSMI CNS13438	 R33025  警告使用者： 這是甲類的資訊產品，在居住的環境中使用時，可能會造成射頻干擾，在這種情況下，使用者會被要求採取某些適當的對策

## 9.6 Electromagnetic Compatibility Notices

### 9.6.1 USA

This device complies with Part 15 of the FCC Rules. Operation is subject to the following two conditions: (1) this device may not cause harmful interference, and (2) this device must accept any interference received, including interference that may cause undesired operation.

For questions related to the EMC performance of this product, contact:

Intel Corporation  
5200 N.E. Elam Young Parkway  
Hillsboro, OR 97124  
1-800-628-8686

This equipment has been tested and found to comply with the limits for a Class A digital device, pursuant to Part 15 of the FCC Rules. These limits are designed to provide reasonable protection against harmful interference in a residential installation. This equipment generates, uses, and can radiate radio frequency energy and, if not installed and used in accordance with the instructions, may cause harmful interference to radio communications. However, there is no guarantee that interference will not occur in a particular installation. If this equipment does cause harmful interference to radio or television reception, which can be determined by turning the equipment off and on, the user is encouraged to try to correct the interference by one or more of the following measures:

## Environmental and Regulatory Specifications

- Reorient or relocate the receiving antenna.
- Increase the separation between the equipment and the receiver.
- Connect the equipment to an outlet on a circuit other than the one to which the receiver is connected.
- Consult the dealer or an experienced radio/TV technician for help.

Any changes or modifications not expressly approved by the grantee of this device could void the user's authority to operate the equipment. The customer is responsible for ensuring compliance of the modified product.

Only peripherals (computer input/output devices, terminals, printers, etc.) that comply with FCC Class B limits may be attached to this computer product. Operation with noncompliant peripherals is likely to result in interference to radio and TV reception.

All cables used to connect to peripherals must be shielded and grounded. Operation with cables, connected to peripherals that are not shielded and grounded may result in interference to radio and TV reception.

### 9.6.2 FCC Verification Statement

Product Type: SR1530; S5000VCL

This device complies with Part 15 of the FCC Rules. Operation is subject to the following two conditions: (1) This device may not cause harmful interference, and (2) this device must accept any interference received, including interference that may cause undesired operation.

For questions related to the EMC performance of this product, contact:

Intel Corporation  
5200 N.E. Elam Young Parkway  
Hillsboro, OR 97124-6497

Phone: 1 (800)-INTEL4U or 1 (800) 628-8686

### 9.6.3 ICES-003 (Canada)

Cet appareil numérique respecte les limites bruits radioélectriques applicables aux appareils numériques de Classe A prescrites dans la norme sur le matériel brouilleur: "Appareils Numériques", NMB-003 édictée par le Ministre Canadien des Communications.

(English translation of the notice above) This digital apparatus does not exceed the Class A limits for radio noise emissions from digital apparatus set out in the interference-causing equipment standard entitled "Digital Apparatus," ICES-003 of the Canadian Department of Communications.

### 9.6.4 Europe (CE Declaration of Conformity)

This product has been tested in accordance too, and complies with the Low Voltage Directive (73/23/EEC) and EMC Directive (89/336/EEC). The product has been marked with the CE Mark to illustrate its compliance.

### 9.6.5 Japan EMC Compatibility

Electromagnetic Compatibility Notices (International)

この装置は、情報処理装置等電波障害自主規制協議会（VCCI）の基準に基づくクラス A 情報技術装置です。この装置を家庭環境で使用すると電波妨害を引き起こすことがあります。この場合には使用者が適切な対策を講ずるよう要求されることがあります。

English translation of the notice above:

This is a Class A product based on the standard of the Voluntary Control Council For Interference (VCCI) from Information Technology Equipment. If this is used near a radio or television receiver in a domestic environment, it may cause radio interference. Install and use the equipment according to the instruction manual.

### 9.6.6 BSMI (Taiwan)

The BSMI Certification number and the following warning is located on the product safety label which is located on the bottom side (pedestal orientation) or side (rack mount configuration).

警告使用者：

這是甲類的資訊產品，在居住的環境中使用時，可能會造成射頻干擾，在這種情況下，使用者會被要求採取某些適當的對策。

### 9.6.7 RRL (Korea)

Following is the RRL certification information for Korea.

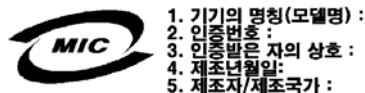

English translation of the notice above:

1. Type of Equipment (Model Name): On License and Product
2. Certification No.: On RRL certificate. Obtain certificate from local Intel representative
3. Name of Certification Recipient: Intel Corporation
4. Date of Manufacturer: Refer to date code on product
5. Manufacturer/Nation: Intel Corporation/Refer to country of origin marked on product

## Environmental and Regulatory Specifications

### 9.6.8 CNCA (CCC-China)



The CCC Certification Marking and EMC warning is located on the outside rear area of the product.

#### 声明





此为A级产品，在生活环境中，该产品可能会造成无线电干扰。在这种情况下，可能需要用户对其干扰采取可行的措施。

## 9.7 Product Ecology Compliance

Intel has a system in place to restrict the use of banned substances in accordance with world wide product ecology regulatory requirements. The following is Intel's product ecology compliance criteria.

Compliance Regional Description	Compliance Reference	Compliance Reference Marking Example
California	California Code of Regulations, Title 22, Division 4.5; Chapter 33: Best Management Practices for Perchlorate Materials.	Special handling may apply. See <a href="http://www.dtsc.ca.gov/hazardouswaste/perchlorate">www.dtsc.ca.gov/hazardouswaste/perchlorate</a> This notice is required by California Code of Regulations, Title 22, Division 4.5; Chapter 33: Best Management Practices for Perchlorate Materials. This product / part includes a battery which contains Perchlorate material.
China	<p><b>China RoHS</b> Administrative Measures on the Control of Pollution Caused by Electronic Information Products” (EIP) #39. Referred to as China RoHS. Mark requires to be applied to retail products only. Mark used is the Environmental Friendly Use Period (EFUP). Number represents years.</p>	
	<p><b>China Recycling (GB18455-2001)</b> Mark requires to be applied to be retail product only. Marking applied to bulk packaging and single packages. Not applied to internal packaging such as plastics, foams, etc.</p>	

**Environmental and Regulatory Specifications**

Compliance Regional Description	Compliance Reference	Compliance Reference Marking Example
Intel Internal Specification	All materials, parts and subassemblies must not contain restricted materials as defined in Intel's <b><i>Environmental Product Content Specification</i></b> of Suppliers and Outsourced Manufacturers – <a href="http://supplier.intel.com/ehs/environmental.htm">http://supplier.intel.com/ehs/environmental.htm</a>	None Required
Europe	<b>Waste Electrical and Electronic Equipment (WEEE) Directive 2002/96/EC</b> – Mark applied to system level products only.	
	<b>European Directive 2002/95/EC - Restriction of Hazardous Substances (RoHS)</b> Threshold limits and banned substances are noted below. Quantity limit of 0.1% by mass (1000 PPM) for: Lead, Mercury, Hexavalent Chromium, Polybrominated Biphenyls Diphenyl Ethers (PBB/PBDE) Quantity limit of 0.01% by mass (100 PPM) for: Cadmium	None Required
Germany	<b>German Green Dot</b> Applied to Retail Packaging Only for Boxed Boards	
Intel Internal Specification	All materials, parts and subassemblies must not contain restricted materials as defined in Intel's <b><i>Environmental Product Content Specification</i></b> of Suppliers and Outsourced Manufacturers – <a href="http://supplier.intel.com/ehs/environmental.htm">http://supplier.intel.com/ehs/environmental.htm</a>	None Required
International	<b>ISO11469</b> - Plastic parts weighing >25gm are intended to be marked with per ISO11469.	>PC/ABS<
	Recycling Markings – Fiberboard (FB) and Cardboard (CB) are marked with international recycling marks. Applied to outer bulk packaging and single package.	
Japan	<b>Japan Recycling</b> Applied to Retail Packaging Only for Boxed Boards	



## 9.8 Other Markings

Compliance Description	Compliance Reference	Compliance Reference Marking Example
Stand-by Power	60950 Safety Requirement Applied to product is stand-by power switch is used.	
Multiple Power Cords	60950 Safety Requirement Applied to product if more than one power cord is used.	<p>English: This unit has more than one power supply cord. To reduce the risk of electrical shock, disconnect (2) two power supply cords before servicing.</p> <p>Simplified Chinese: 注意： 本设备包括多条电源系统电缆。为避免遭受电击，在进行维修之前应断开两（2）条电源系统电缆。</p> <p>Traditional Chinese: 注意： 本設備包括多條電源系統電纜。為避免遭受電擊，在進行維修之前應斷開兩（2）條電源系統電纜。</p> <p>German: Dieses Geräte hat mehr als ein Stromkabel. Um eine Gefahr des elektrischen Schlages zu verringern trennen sie beide (2) Stromkabeln bevor Instandhaltung.</p>
Ground Connection	60950 Deviation for Nordic Countries	<p>Line1 : "WARNING:"</p> <p>Swedish on line2: "Apparaten skall anslutas till jordat uttag, när den ansluts till ett nätverk."</p> <p>Finnish on line 3: "Laite on liitettävä suojamaadoituskoskettimilla varustettuun pistorasiaan."</p> <p>English on line 4: "Connect only to a properly earth grounded outlet."</p>
Country of Origin	Logistic Requirements Applied to products to indicate where product was made.	Made in XXXX

**This page intentionally left blank**

## ***Appendix A: Integration and Usage Tips***

This section provides a list of useful information that is unique to the Intel® Server Systems SR1530CL / SR1530HCL / SR1530HCLS and should be kept in mind while integrating and server system.

- Only low-profile (1.2 inch or 30.48 mm) FBDIMMs can be used in the server systems.
- Processor fans are not needed and are not supported. The system fan blowers and power supply fans provide the necessary cooling needed for the system. Using a processor fan in these systems may cause Intel® System Management Software to incorrectly monitor the system fans.
- The air duct must be used to maintain system thermals.
- System fan blowers are not hot swappable
- A screw on the front edge of the top cover is required when the unit is installed in a user-accessible environment.
- The FRUSDR utility must be run to load the proper sensor data records for the server system onto the server board.
- Make sure the latest system software is loaded. This includes system BIOS, FRUSDR, and BMC firmware. The latest system software can be downloaded from <http://support.intel.com/support/motherboards/server/S5000VCL/>

## Appendix B: POST Code Diagnostic LED Decoder

During the system boot process, BIOS executes a number of platform configuration processes, each of which is assigned a specific hex POST code number. As each configuration routine is started, BIOS will display the given POST code to the POST Code Diagnostic LEDs found on the back edge of the server board. To assist in troubleshooting a system hang during the POST process, the Diagnostic LEDs can be used to identify the last POST process to be executed.

Each POST code will be represented by a combination of colors from the four LEDs. The LEDs are capable of displaying three colors: green, red, and amber. The POST codes are divided into two nibbles, an upper nibble and a lower nibble. Each bit in the upper nibble is represented by a red LED and each bit in the lower nibble is represented by a green LED. If both bits are set in the upper and lower nibbles then both red and green LEDs are lit, resulting in an amber color. If both bits are clear, then the LED is off.

In the below example, BIOS sends a value of ACh to the diagnostic LED decoder. The LEDs are decoded as follows:

- red bits = 1010b = Ah
- green bits = 1100b = Ch

Since the red bits correspond to the upper nibble and the green bits correspond to the lower nibble, the two are concatenated to be ACh.

**Table 25: POST Progress Code LED Example**

LEDs	8h		4h		2h		1h	
	Red	Green	Red	Green	Red	Green	Red	Green
ACh	1	1	0	1	1	0	0	0
Result	Amber		Green		Red		Off	
	MSB				LSB			

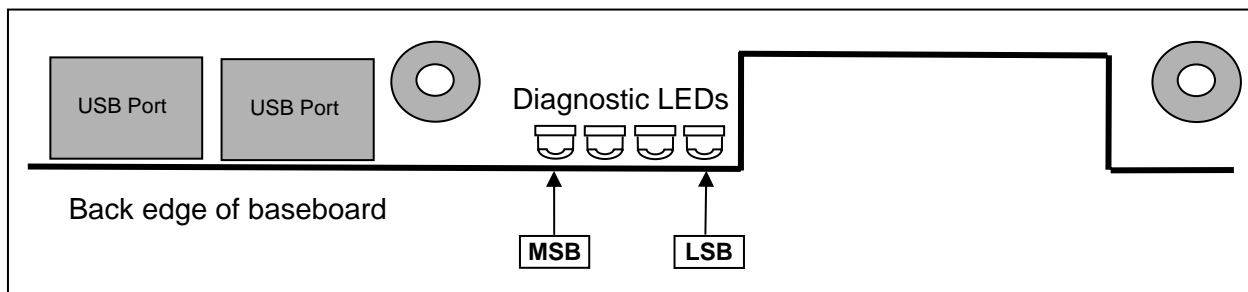

**Figure 21. Diagnostic LED Placement Diagram Example**

Table 26. Diagnostic LED POST Code Decoder

Checkpoint	Diagnostic LED Decoder				Description
	G=Green, R=Red, A=Amber				
	MSB			LSB	
<b>Host Processor</b>					
0x10h	OFF	OFF	OFF	R	Power-on initialization of the host processor (bootstrap processor)
0x11h	OFF	OFF	OFF	A	Host processor cache initialization (including AP)
0x12h	OFF	OFF	G	R	Starting application processor initialization
0x13h	OFF	OFF	G	A	SMM initialization
<b>Chipset</b>					
0x21h	OFF	OFF	R	G	Initializing a chipset component
<b>Memory</b>					
0x22h	OFF	OFF	A	OFF	Reading configuration data from memory (SPD on DIMM)
0x23h	OFF	OFF	A	G	Detecting presence of memory
0x24h	OFF	G	R	OFF	Programming timing parameters in the memory controller
0x25h	OFF	G	R	G	Configuring memory parameters in the memory controller
0x26h	OFF	G	A	OFF	Optimizing memory controller settings
0x27h	OFF	G	A	G	Initializing memory, such as ECC init
0x28h	G	OFF	R	OFF	Testing memory
<b>PCI Bus</b>					
0x50h	OFF	R	OFF	R	Enumerating PCI busses
0x51h	OFF	R	OFF	A	Allocating resources to PCI busses
0x52h	OFF	R	G	R	Hot Plug PCI controller initialization
0x53h	OFF	R	G	A	Reserved for PCI bus
0x54h	OFF	A	OFF	R	Reserved for PCI bus
0x55h	OFF	A	OFF	A	Reserved for PCI bus
0x56h	OFF	A	G	R	Reserved for PCI bus
0x57h	OFF	A	G	A	Reserved for PCI bus
<b>USB</b>					
0x58h	G	R	OFF	R	Resetting USB bus
0x59h	G	R	OFF	A	Reserved for USB devices
<b>ATA / ATAPI / SATA</b>					
0x5Ah	G	R	G	R	Resetting PATA / SATA bus and all devices
0x5Bh	G	R	G	A	Reserved for ATA
<b>SMBUS</b>					
0x5Ch	G	A	OFF	R	Resetting SMBUS
0x5Dh	G	A	OFF	A	Reserved for SMBUS
<b>Local Console</b>					
0x70h	OFF	R	R	R	Resetting the video controller (VGA)
0x71h	OFF	R	R	A	Disabling the video controller (VGA)
0x72h	OFF	R	A	R	Enabling the video controller (VGA)
<b>Remote Console</b>					
0x78h	G	R	R	R	Resetting the console controller
0x79h	G	R	R	A	Disabling the console controller
0x7Ah	G	R	A	R	Enabling the console controller
<b>Keyboard (PS2 or USB)</b>					
0x90h	R	OFF	OFF	R	Resetting the keyboard
0x91h	R	OFF	OFF	A	Disabling the keyboard

Checkpoint	Diagnostic LED Decoder				Description
	G=Green, R=Red, A=Amber				
	MSB			LSB	
0x92h	R	OFF	G	R	Detecting the presence of the keyboard
0x93h	R	OFF	G	A	Enabling the keyboard
0x94h	R	G	OFF	R	Clearing keyboard input buffer
0x95h	R	G	OFF	A	Instructing keyboard controller to run Self Test (PS2 only)
<b>Mouse (PS2 or USB)</b>					
0x98h	A	OFF	OFF	R	Resetting the mouse
0x99h	A	OFF	OFF	A	Detecting the mouse
0x9Ah	A	OFF	G	R	Detecting the presence of mouse
0x9Bh	A	OFF	G	A	Enabling the mouse
<b>Fixed Media</b>					
0xB0h	R	OFF	R	R	Resetting fixed media device
0xB1h	R	OFF	R	A	Disabling fixed media device
0xB2h	R	OFF	A	R	Detecting presence of a fixed media device (IDE hard drive detection, etc.)
0xB3h	R	OFF	A	A	Enabling / configuring a fixed media device
<b>Removable Media</b>					
0xB8h	A	OFF	R	R	Resetting removable media device
0xB9h	A	OFF	R	A	Disabling removable media device
0xBAh	A	OFF	A	R	Detecting presence of a removable media device (IDE CDROM detection, etc.)
0xBCh	A	G	R	R	Enabling / configuring a removable media device
<b>Boot Device Selection</b>					
0xD0	R	R	OFF	R	Trying boot device selection
0xD1	R	R	OFF	A	Trying boot device selection
0xD2	R	R	G	R	Trying boot device selection
0xD3	R	R	G	A	Trying boot device selection
0xD4	R	A	OFF	R	Trying boot device selection
0xD5	R	A	OFF	A	Trying boot device selection
0xD6	R	A	G	R	Trying boot device selection
0xD7	R	A	G	A	Trying boot device selection
0xD8	A	R	OFF	R	Trying boot device selection
0xD9	A	R	OFF	A	Trying boot device selection
0XDA	A	R	G	R	Trying boot device selection
0xDB	A	R	G	A	Trying boot device selection
0xDC	A	A	OFF	R	Trying boot device selection
0xDE	A	A	G	R	Trying boot device selection
0xDF	A	A	G	A	Trying boot device selection
<b>Pre-EFI Initialization (PEI) Core</b>					
0xE0h	R	R	R	OFF	Started dispatching early initialization modules (PEIM)
0xE2h	R	R	A	OFF	Initial memory found, configured, and installed correctly
0xE1h	R	R	R	G	Reserved for initialization module use (PEIM)
0xE3h	R	R	A	G	Reserved for initialization module use (PEIM)
<b>Driver Execution Environment (DXE) Core</b>					
0xE4h	R	A	R	OFF	Entered EFI driver execution phase (DXE)
0xE5h	R	A	R	G	Started dispatching drivers
0xE6h	R	A	A	OFF	Started connecting drivers
<b>DXE Drivers</b>					

## Appendix B: POST Code Diagnostic LED Decoder

Checkpoint	Diagnostic LED Decoder				Description
	G=Green, R=Red, A=Amber				
	MSB			LSB	
0xE7h	R	A	A	G	Waiting for user input
0xE8h	A	R	R	OFF	Checking password
0xE9h	A	R	R	G	Entering BIOS setup
0xEAh	A	R	A	OFF	Flash Update
0xEEh	A	A	A	OFF	Calling Int 19. One beep unless silent boot is enabled.
0xEFh	A	A	A	G	Unrecoverable boot failure / S3 resume failure
<b>Runtime Phase / EFI Operating System Boot</b>					
0xF4h	R	A	R	R	Entering Sleep state
0xF5h	R	A	R	A	Exiting Sleep state
0xF8h	A	R	R	R	Operating system has requested EFI to close boot services (ExitBootServices ( ) has been called)
0xF9h	A	R	R	A	Operating system has switched to virtual address mode (SetVirtualAddressMap ( ) has been called)
0xFAh	A	R	A	R	Operating system has requested the system to reset (ResetSystem ( ) has been called)
<b>Pre-EFI Initialization Module (PEIM) / Recovery</b>					
0x30h	OFF	OFF	R	R	Crisis recovery has been initiated because of a user request
0x31h	OFF	OFF	R	A	Crisis recovery has been initiated by software (corrupt flash)
0x34h	OFF	G	R	R	Loading crisis recovery capsule
0x35h	OFF	G	R	A	Handing off control to the crisis recovery capsule
0x3Fh	G	G	A	A	Unable to complete crisis recovery.

## Appendix C: POST Error Beep Codes

The following table lists POST error beep codes. Prior to system video initialization, BIOS uses these beep codes to inform users on error conditions. The beep code is followed by a user visible code on POST Progress LEDs.

**Table 27. POST Error Beep Codes**

Beeps	Error Message	POST Progress Code	Description
3	Memory error		System halted because a fatal error related to the memory was detected.
6	BIOS rolling back error		The system has detected a corrupted BIOS in the flash part, and is rolling back to the last good BIOS.

The BMC may generate beep codes upon detection of failure conditions. Beep codes are sounded each time the problem is discovered, such as on each power-up attempt, but are not sounded continuously. Codes that are common across all Intel® Server Boards and systems that use the Intel® 5000 Chipset are listed in Table 28. Each digit in the code is represented by a sequence of beeps whose count is equal to the digit.

**Table 28. BMC Beep Codes**

Code	Reason for Beep	Associated Sensors	Supported?
1-5-2-1	CPU: Empty slot / population error – Processor slot 1 is not populated.	CPU Population Error	Yes
1-5-2-2	CPU: No processors (terminators only)	N/A	No
1-5-2-3	CPU: Configuration error (e.g., VID mismatch)	N/A	No
1-5-2-4	CPU: Configuration error (e.g., BSEL mismatch)	N/A	No
1-5-4-2	Power fault: DC power unexpectedly lost (power good dropout)	Power Unit – power unit failure offset	Yes
1-5-4-3	Chipset control failure	N/A	No
1-5-4-4	Power control fault	Power Unit – soft power control failure offset	Yes



## Glossary

<b>Word / Acronym</b>	<b>Definition</b>
ACA	Australian Communication Authority
ANSI	American National Standards Institute
BMC	Baseboard Management Controller
CMOS	Complementary Metal Oxide Silicon
D2D	DC-to-DC
EMP	Emergency Management Port
FP	Front Panel
FRB	Fault Resilient Boot
FRU	Field Replaceable Unit
LCD	Liquid Crystal Display
LPC	Low-Pin Count
MTBF	Mean Time Between Failure
MTTR	Mean Time to Repair
OTP	Over-temperature Protection
OVP	Over-voltage Protection
PFC	Power Factor Correction
PSU	Power Supply Unit
RI	Ring Indicate
SCA	Single Connector Attachment
SDR	Sensor Data Record
SE	Single-Ended
UART	Universal Asynchronous Receiver Transmitter
USB	Universal Serial Bus
VCCI	Voluntary Control Council for Interference

## ***Reference Documents***

See the following documents for additional information:

- Intel® Server Board S5000VCL Technical Product Specification
- Intel® S5000 Series Chipsets Server Board Family Data Sheet
- Intel® Server Board S5000VCL Tested Hardware and OS List
- Intel® Server Board S5000VCL / Intel® Server Chassis SR1530CL Spares/Parts List and Configuration Guide