

Intel[®] Server System SR1600UR Service Guide

**A Guide for Technically Qualified Assemblers of Intel[®] Identified Subassemblies/
Products**

Intel Order Number E52880-005

Disclaimer

Information in this document is provided in connection with Intel® products. No license, express or implied, by estoppel or otherwise, to any intellectual property rights is granted by this document. Except as provided in Intel's Terms and Conditions of Sale for such products, Intel assumes no liability whatsoever, and Intel disclaims any express or implied warranty, relating to sale and/or use of Intel products including liability or warranties relating to fitness for a particular purpose, merchantability, or infringement of any patent, copyright or other intellectual property right. Intel products are not designed, intended or authorized for use in any medical, life saving, or life sustaining applications or for any other application in which the failure of the Intel product could create a situation where personal injury or death may occur. Intel may make changes to specifications and product descriptions at any time, without notice.

Intel server boards contain a number of high-density VLSI and power delivery components that need adequate airflow for cooling. Intel's own chassis are designed and tested to meet the intended thermal requirements of these components when the fully integrated system is used together. It is the responsibility of the system integrator that chooses not to use Intel developed server building blocks to consult vendor datasheets and operating parameters to determine the amount of airflow required for their specific application and environmental conditions. Intel Corporation can not be held responsible if components fail or the server board does not operate correctly when used outside any of their published operating or non-operating limits.

Intel, Intel Pentium, and Intel Xeon are trademarks or registered trademarks of Intel Corporation or its subsidiaries in the United States and other countries.

* Other names and brands may be claimed as the property of others.

Copyright © 2008-2011, Intel Corporation. All Rights Reserved

Preface

About this Manual

Thank you for purchasing and using the Intel® Server System SR1600UR.

This manual is written for system technicians who are responsible for troubleshooting, upgrading, and repairing this server system. This document provides reference information, feature information, and step by step instructions on how to add and replace components on the server system. For the latest version of this manual, see http://www.intel.com/p/en_US/support/highlights/server/s5520ur.

Manual Organization

Chapter 1 provides information on the contents of each server system and a list of reference resources. This includes a list of technical documents that give additional details on the Intel® Server System SR1600UR, and the location where they can be found.

Chapter 2 provides a brief overview of the server system. This includes a list of the server system features, illustrations of the product, and product diagrams to help you identify components and their locations.

Chapter 3 provides instructions on adding and replacing components. It provides step-by-step instructions and diagrams for installing or replacing components such as the fans, power supply, drives, and other components.

Chapter 4 provides instructions on using the utilities that are shipped with the board or that may be required to update the system. This includes information for navigating through the BIOS Setup screens, performing a BIOS update, and resetting the password or BIOS defaults.

The back of this manual provides technical specifications, regulatory information, “getting help” information, and the warranty.

Safety Information

Important Safety Instructions

Read all caution and safety statements in this document before performing any of the instructions. See also Intel Server Boards and Server Chassis Safety Information on the *Intel® Server Deployment Toolkit 3.0 CD* and/or at <http://www.intel.com/support/motherboards/server/sb/cs-010770.htm>.

Wichtige Sicherheitshinweise

Lesen Sie zunächst sämtliche Warn- und Sicherheitshinweise in diesem Dokument, bevor Sie eine der Anweisungen ausführen. Beachten Sie hierzu auch die Sicherheitshinweise zu Intel-Serverplatinen und Servergehäusen auf der *Intel® Server Deployment Toolkit 3.0 CD* oder unter <http://www.intel.com/support/motherboards/server/sb/cs-010770.htm>.

Consignes de sécurité

Lisez attention toutes les consignes de sécurité et les mises en garde indiquées dans ce document avant de suivre toute instruction. Consultez Intel Server Boards and Server Chassis Safety Information sur le *Intel® Server Deployment Toolkit 3.0 CD* ou bien rendez-vous sur le site <http://www.intel.com/support/motherboards/server/sb/cs-010770.htm>.

Instrucciones de seguridad importantes

Lea todas las declaraciones de seguridad y precaución de este documento antes de realizar cualquiera de las instrucciones. Vea Intel Server Boards and Server Chassis Safety Information en el *Intel® Server Deployment Toolkit 3.0 CD* y/o en <http://www.intel.com/support/motherboards/server/sb/cs-010770.htm>.

重要安全指导

在执行任何指令之前，请阅读本文件中的所有注意事项及安全声明。并参阅 <http://www.intel.com/support/motherboards/server/sb/cs-010770.htm> 上的 *Intel Server Boards and Server Chassis Safety Information*（《Intel 服务器主板与服务器机箱安全信息》）。

Warnings

Heed safety instructions: Before working with your server product, whether you are using this guide or any other resource as a reference, pay close attention to the safety instructions. You must adhere to the assembly instructions in this guide to ensure and maintain compliance with existing product certifications and approvals. Use only the described, regulated components specified in this guide. Use of other products/ components will void the UL listing and other regulatory approvals of the product and will most likely result in noncompliance with product regulations in the region(s) in which the product is sold.

System power on/off: The power button DOES NOT turn off the system AC power. To remove power from system, you must unplug the AC power cord from the wall outlet. Make sure the AC power cord is unplugged before you open the chassis, add, or remove any components.

Hazardous conditions, devices and cables: Hazardous electrical conditions may be present on power, telephone, and communication cables. Turn off the server and disconnect the power cord, telecommunications systems, networks, and modems attached to the server before opening it. Otherwise, personal injury or equipment damage can result.

Electrostatic discharge (ESD) and ESD protection: ESD can damage disk drives, boards, and other parts. We recommend that you perform all procedures in this chapter only at an ESD workstation. If one is not available, provide some ESD protection by wearing an antistatic wrist strap attached to chassis ground any unpainted metal surface on your server when handling parts.

ESD and handling boards: Always handle boards carefully. They can be extremely sensitive to ESD. Hold boards only by their edges. After removing a board from its protective wrapper or from the server, place the board component side up on a grounded, static free surface. Use a conductive foam pad if available but not the board wrapper. Do not slide board over any surface.

Installing or removing jumpers: A jumper is a small plastic encased conductor that slips over two jumper pins. Some jumpers have a small tab on top that you can grip with your fingertips or with a pair of fine needle nosed pliers. If your jumpers do not have such a tab, take care when using needle nosed pliers to remove or install a jumper; grip the narrow sides of the jumper with the pliers, never the wide sides. Gripping the wide sides can damage the contacts inside the jumper, causing intermittent problems with the function controlled by that jumper. Take care to grip with, but not squeeze, the pliers or other tool you use to remove a jumper, or you may bend or break the pins on the board.

Table of Contents

Preface	iii
About this Manual	iii
Manual Organization	iii
Safety Information	v
Important Safety Instructions	v
Wichtige Sicherheitshinweise	v
Consignes de sécurité	v
Instrucciones de seguridad importantes	v
Warnings	vii
Chapter 1: Server System Contents and References	1
Server System Contents	1
Intel® Server System SR1600UR Contents	1
Intel® Server System SR1600URHS Contents	2
Additional Information and Software	3
Chapter 2: Server System Features	5
Server System Feature Overview	6
Server System Components	9
Intel® Light-Guided Diagnostics	10
Server Board Components	14
Configuration Jumpers	16
Front of Server System	17
Peripheral Devices	17
Control Panel	19
Bezels	22
Rear of Server System	22
Back Panel Connectors	23
SAS/SATA Backplanes	24
Active Backplane	24
Passive Backplane	25
RAID Support	26
Advanced Management Options	26
Intel® Remote Management Module 3	26
Rack Mount Options	27
Chapter 3: Hardware Installations and Upgrades	29
Before You Begin	29
Tools and Supplies Needed	29
System References	29

Cable Routing	30
Fixed Mount Hard Drive System	30
Hot-swap Hard Drive System	32
Removing and Installing from a Rack	33
Fixed Bracket Rack Mount Removal	34
Fixed Bracket Rack Mount Installation	34
Basic Rail Rack Mount Removal	35
Basic Rail Rack Mount Installation	35
Tool-less Rail Rack Mount Servicing	36
Installing and Removing the Front Bezel	36
Installing the Front Bezel	37
Removing the Front Bezel	38
Removing and Installing the System Cover	38
Removing the System Cover	38
Installing the System Cover	39
Removing and Installing the PCI Riser Assembly	41
Removing the PCI Riser Assembly	41
Installing the PCI Riser Assembly	42
Replacing a PCI Riser Card	43
Removing the PCI Express* Riser Card	43
Installing the Replacement PCI Express* Riser Card	44
Installing and Removing a PCI Add-in Card	44
Installing a PCI Add-in Card	44
Removing a PCI Add-in Card	45
Removing and Installing the Processor Air Duct	46
Removing the Processor Air Duct	46
Installing the Processor Air Duct	47
Installing and Removing Memory	47
Installing DIMMs	48
Removing DIMMs	49
Installing and Removing the Processor	49
Installing the Processor	49
Installing the Heatsink	52
Removing the Heatsink	54
Removing the Processor	55
Removing and Installing the Small Air Baffle	56
Removing the Small Air Baffle	56
Installing the Small Air Baffle	56
Installing and Removing a Fixed Mount Hard Drive (Fixed Mount Hard Drive System Only) .	57
Installing a Fixed Mount Hard Disk Drive	57
Removing a Fixed Mount Hard Disk Drive	60
Installing and Removing a Hot-swap Hard Drive (Hot-swap Hard Drive System Only)	61
Installing a Hot-swap SAS or SATA Hard Disk Drive	61

Removing a Hot-swap SAS or SATA Hard Disk Drive	63
Installing and Removing a Slimline Optical Drive or Internal USB Floppy	63
Installing a Slimline Optical Drive or Internal USB Floppy	64
Removing a Slimline Optical Drive or Internal USB Floppy	66
Filling Empty Server System Bays	67
Installing and Removing the I/O Expansion Module	68
Installing the I/O Expansion Module	68
Removing the I/O Expansion Module	69
Installing and Removing the Intel® Remote Management Module 3	70
Installing the Intel® RMM3	70
Removing the Intel® RMM3	73
Removing and Installing the Fan Board (Fixed Mount Hard Drive System Only)	74
Removing the Fan Board	74
Installing the Fan Board	76
Installing and Removing the Backplane Board (Hot-swap Hard Drive System Only)	77
Installing the Backplane Board	77
Removing the Backplane Board	81
Removing and Installing the Server Board	83
Removing the Server Board	83
Installing the Server Board	84
Replacing the Backup Battery	86
Replacing the Power Supply	87
Replacing the Control Panel Module (Hot-swap Hard Drive System only)	88
Removing and Installing the Fan Assembly	90
Removing the System Fan Assembly	90
Installing the System Fan Assembly	91
Replacing a System Fan	93
Installing and Removing the Rack Handles	94
Installing the Rack Handles	94
Removing the Rack Handles	95
Chapter 4: Server Utilities	97
Using the BIOS Setup Utility	97
Entering BIOS Setup	97
If You Cannot Access Setup	97
Setup Menus	97
Upgrading the BIOS	99
Preparing for the Upgrade	99
Upgrading the BIOS	100
Clearing the Password	100
Restoring the BIOS Defaults	102
Appendix A: Technical Reference	103
600-W Single Power Supply Input Voltages	103
600-W Single Power Supply Output Voltages	104

System Environmental Specifications	105
Appendix B: Intel® Server Issue Report Form	107
Appendix C: LED Decoder	113
Appendix D: Getting Help	121
Warranty Information	121
Appendix E: Regulatory and Certification Information	123
Product Regulatory Compliance	123
Product Safety Compliance	123
Product EMC Compliance - Class A Compliance	124
Product Ecology Compliance	125
Certifications/Registrations/Declarations	125
Product Regulatory Compliance Markings	126
Rack Mount Installation Guidelines	130
Power Cord Usage Guidelines	131
Electromagnetic Compatibility Notices	132
FCC Verification Statement (USA)	132
ICES-003 (Canada)	133
CE Declaration of Conformity (Europe)	133
VCCI (Japan)	133
BSMI (Taiwan)	133
KCC (Korea)	134
Regulated Specified Components	134
Appendix F: Installation/Assembly Safety Instructions	135
English	135
Deutsch	137
Français	139
Español	141
Italiano	143
Appendix G: Safety Information	147
English	147
Server Safety Information	147
Safety Warnings and Cautions	147
Intended Application Uses	148
Site Selection	148
Equipment Handling Practices	148
Power and Electrical Warnings	149
System Access Warnings	150
Rack Mount Warnings	150
Electrostatic Discharge (ESD)	151
Other Hazards	151
Deutsch	152

Sicherheitshinweise für den Server	152
Sicherheitshinweise und Vorsichtsmaßnahmen	152
Zielbenutzer der Anwendung	153
Standortauswahl	153
Handhabung von Geräten	153
Warnungen zu Netzspannung und Elektrizität	154
Warnhinweise für den Systemzugang	155
Warnhinweise für Racks	155
Elektrostatische Entladungen (ESD)	156
Andere Gefahren	156
Français	157
Consignes de securite sur le serveur	157
Sécurité: avertissements et mises en garde	157
Domaines d'utilisation prévus	158
Sélection d'un emplacement	158
Pratiques de manipulation de l'équipement	159
Alimentation et avertissements en matière d'électricité	159
Avertissements sur le cordon d'alimentation	160
Avertissements sur l'accès au système	160
Avertissements sur le montage en rack	161
Décharges électrostatiques (ESD)	162
Autres risques	162
Périphériques laser	163
Español	163
Información de seguridad del servidor	163
Advertencias y precauciones sobre seguridad	163
Aplicaciones y usos previstos	164
Selección de la ubicación	164
Manipulación del equipo	165
Advertencias de alimentación y eléctricas	165
Advertencias sobre el cable de alimentación	165
Advertencias el acceso al sistema	166
Advertencias sobre el montaje en bastidor	167
Descarga electrostática (ESD)	167
Otros riesgos	168

List of Figures

Figure 1. Intel® Server System SR1600UR.....	5
Figure 2. Server System Components	9
Figure 3. Intel® Light-Guided Diagnostic LEDs - Server Board.....	11
Figure 4. Intel® Light-Guided Diagnostic LEDs - Fan Board	12
Figure 5. Intel® Light-Guided Diagnostic LEDs - Hot-swap Backplane (Passive Shown)	12
Figure 6. Intel® Light-Guided Diagnostic LEDs - Standard Control Panel	13
Figure 7. Server Board Connector and Component Locations	15
Figure 8. Configuration Jumpers	16
Figure 9. Optional Peripherals.....	17
Figure 10. Standard Control Panel.....	20
Figure 11. Intel® Local Control Panel.....	21
Figure 12. Server System Back Panel	22
Figure 13. Back Panel Connectors.....	23
Figure 14. Active SAS Backplane Components	24
Figure 15. Passive SAS/SATA Backplane Components.....	25
Figure 16. Cable Routing (Fixed Mount Hard Drive System)	30
Figure 17. Cabling Around the Small Air Baffle (Fixed Mount Hard Drive System)	31
Figure 18. Cable Routing (Hot-swap Hard Drive System).....	32
Figure 19. Cabling Around the Small Air Baffle (Hot-swap Hard Drive System)	33
Figure 20. Front View with Bezel supporting the Standard Control Panel	36
Figure 21. Front View with Bezel supporting the Intel® Local Control Panel	37
Figure 22. Installing the Front Bezel.....	37
Figure 23. Removing the Front Bezel.....	38
Figure 24. Removing the Server System Cover.....	39
Figure 25. Installing the Server System Cover.....	40
Figure 26. Removing PCI Riser Assembly from the Server System	41
Figure 27. Installing PCI Riser Assembly into the Server System.....	42
Figure 28. Removing the PCI Express* Riser Card	43
Figure 29. Installing the Replacement PCI Express* Riser Card	44
Figure 30. Installing a Full-height Add-In Card.....	45
Figure 31. Removing a Full-height Add-In Card.....	46
Figure 32. Removing the Processor Air Duct.....	47
Figure 33. Installing the Processor Air Duct.....	47
Figure 34. Installing the Memory.....	48
Figure 35. Lifting the Processor Socket Lever	50
Figure 36. Opening the Load Plate	50
Figure 37. Removing the Protective Socket Cover	51
Figure 38. Removing the Processor Protective Cover	51
Figure 39. Installing the Processor.....	52
Figure 40. Closing the Load Plate.....	52
Figure 41. Installing the Heatsink (1U Passive Heatsink Shown)	53
Figure 42. Removing the Heatsink.....	55

Figure 43. Removing the Small Air Baffle	56
Figure 44. Installing the Small Air Baffle	57
Figure 45. Removing Fixed Mount Drive Carrier from the Server System.....	58
Figure 46. Removing the Drive Blank from the Fixed Hard Drive Carrier	58
Figure 47. Installing Fixed Hard Drive into the Carrier	59
Figure 48. Installing the Hard Drive Cables	60
Figure 49. Removing Fixed Hard Drive from the Server System.....	60
Figure 50. Removing Hot-swap Disk Carrier from the Server System.....	61
Figure 51. Removing Retention Device from Drive Carrier.....	62
Figure 52. Installing Hard Drive into Carrier.....	62
Figure 53. Installing Drive Assembly into the Server System	62
Figure 54. Installing an Optical Drive into the Drive Tray.....	64
Figure 55. Installing an Optical Drive Assembly into the Server System	65
Figure 56. Connecting the Optical Device Data Cable	65
Figure 57. Removing the Slimline Optical Drive Assembly from the Server System	66
Figure 58. Removing the Slimline Optical Drive from the Tray	67
Figure 59. Installing the I/O Expansion Module to the Server System.....	69
Figure 60. Removing the I/O Expansion Module from the Server System	70
Figure 61. Removing the Intel® RMM3 filler panel.....	71
Figure 62. Installing the Intel® RMM3 to the bracket	71
Figure 63. Connecting the Intel® RMM3 cable	72
Figure 64. Installing the Intel® RMM3 to the Server System	72
Figure 65. Removing the Intel® RMM3 from the Server System	73
Figure 66. Installing the Intel® RMM3 filler panel.....	74
Figure 67. Removing the Fan Board from the Server System	75
Figure 68. Installing the Fan Board into the Server System	76
Figure 69. Installing the Backplane into the Server System	78
Figure 70. Installing the Bridge Board.....	79
Figure 71. Making Cable Connections.....	80
Figure 72. Removing the Bridge Board from the Server System.....	81
Figure 73. Removing the Backplane from the Server System	82
Figure 74. Removing the Server Board	84
Figure 75. Installing the Server Board	85
Figure 76. Replacing the Backup Battery	87
Figure 77. Removing Power Supply Module from the Server System.....	88
Figure 78. Installing Power Supply Module into the Server System	88
Figure 79. Removing the Standard Control Panel Module	89
Figure 80. Installing Control Panel Module into the Server System.....	89
Figure 81. Removing the Fan Assembly.....	91
Figure 82. Installing the System Fan Assembly.....	92
Figure 83. Removing a Fan from the Fan Module	93
Figure 84. Installing a Fan into the Fan Module.....	94
Figure 85. Installing the Rack Handle	94
Figure 86. Removing the Rack Handle	95
Figure 87. Password Clear Jumper	101
Figure 88. BIOS Default Jumper.....	102
Figure 89. Diagnostic LED Placement Diagram	114

List of Tables

Table 1. Server System References	3
Table 2. Intel® Server System SR1600UR Feature Summary	6
Table 3. NIC LED Descriptions	23
Table 4. Setup Menu Key Use	97
Table 5. Power Supply Input Voltages	103
Table 6. Power Supply Output Capability	104
Table 7. System Environmental Specifications	105
Table 8. POST Progress Code LED Example	113
Table 9. Diagnostic LED POST Code Decoder	114
Table 10. Product Regulatory Compliance Markings	126

1 Server System Contents and References

There are two versions of the Intel® Server System SR1600UR:

- Intel® Server System SR1600UR (fixed mount hard drive system)
- Intel® Server System SR1600URHS (hot-swap hard drive system)

Unless noted otherwise, all references to the Intel® Server System SR1600UR refer to both product codes.

Server System Contents

The Intel® Server System SR1600UR ships with the Intel® Server Board S5520UR. For information about the server board, see the *Intel® Server Board S5520UR Technical Product Specification*.

The contents of each server system are listed below.

Intel® Server System SR1600UR Contents

Your Intel® Server System SR1600UR (fixed mount hard drive system) ships with the following items:

- Intel® Server Board S5520UR, installed in the server system
- One 600-W power supply, installed in the server system
- Full-length and full-height PCI Express* riser card assembly, installed in the server system
- Standard control panel module and cables (I/O and USB), installed in the server system
- Three 3.5-inch fixed mount drive trays with drive filler blanks, installed in the server system
- System fan board and fan board I/O cable, installed in the server system
- System fan assembly, including five dual-rotor fans, installed in the server system
- Processor air duct, installed in the server system
- Two processor heatsinks, installed in the server system
- Blue plastic air baffle, installed in the server system
- A box of hardware components, referred to herein as the “hardware box”

- Optical drive tray assembly, in the hardware box
- Optical drive cable, in the hardware box
- Slimline peripheral bay filler panel, in the hardware box
- Three SATA cables, in the hardware box
- Rack handles, in the hardware box
- Attention document, in the server system product box
- Quick Start User's Guide, in the server system product box
- Intel® Server Deployment Toolkit 3.0 CD
- Intel® System Management Software DVD

Intel® Server System SR1600URHS Contents

Your Intel® Server System SR1600URHS (hot-swap hard drive system) ships with the following items:

- Intel® Server Board S5520UR, installed in the server system
- One 600-W power supply, installed in the server system
- Full-length and full-height PCI Express* riser card assembly, installed in the server system
- Standard control panel module and cables (I/O and USB), installed in the server system
- Three 3.5-inch hot-swap drive trays with drive filler blanks, installed in the server system
- System fan assembly, including five dual-rotor fans, installed in the server system
- Processor air duct, installed in the server system
- Two processor heatsinks, installed in the server system
- Blue plastic air baffle, installed in the server system
- A box of hardware components, referred to herein as the "hardware box"
- Bridge board, in the hardware box
- Optical drive tray assembly, in the hardware box
- Optical drive cable, in the hardware box
- Slimline peripheral bay filler panel, in the hardware box
- Rack handles, in the hardware box
- Attention document, in the server system product box
- Quick Start User's Guide, in the server system product box
- Intel® Server Deployment Toolkit 3.0 CD
- Intel® System Management Software DVD

Note: One of the two hot-swap backplane kits must be ordered separately in order to make the system operational. The following kits are available for purchase:

- Passive hot-swap backplane (Product Order Code: ASR1500PASBP)
- Active hot-swap backplane (Product Order Code: ASR1500SASBP)

Additional Information and Software

If you need more information about this product or information about the accessories that can be used with this server system, use the following resources.

Table 1. Server System References

For this information or software	Use this Document or Software
For in-depth technical information about the server system, including subsystem overviews and mechanical drawings	Intel® Server System SR1600UR Technical Product Specification Available at: http://www.intel.com/p/en_US/support/highlights/server/s5520ur
For in-depth technical information about the server board, including board layout, connector pin-outs, timing information, mechanical drawings and LED information	Intel® Server Board S5520UR Technical Product Specification Available at: http://www.intel.com/p/en_US/support/highlights/server/s5520ur
For basic BIOS settings and chipset information	Intel® Server Board S5520UR Technical Product Specification Available at: http://www.intel.com/p/en_US/support/highlights/server/s5520ur
If you just received this product and you need to assemble your system and install components	<i>Intel® Server System SR1600UR Quick Start User's Guide</i> Available in the product box
Accessories or other Intel server products	Spares, Parts List, and Configuration Guide Available at: http://www.intel.com/p/en_US/support/highlights/server/s5520ur or by using the Server Configurator Tool Available at: http://serverconfigurator.intel.com/default.aspx

Table 1. Server System References

For this information or software	Use this Document or Software
<p>Hardware (peripheral boards, adapter cards) and operating systems that have been tested with this product</p> <p>Processors that have been tested with this product</p> <p>DIMMs that have been tested with this product</p> <p>Hard Drives that have been tested with this product</p>	<p>Server Configurator Tool</p> <p>Available at: http://serverconfigurator.intel.com/default.aspx</p>
<p>Latest drivers, firmware updates (BIOS, BMC, FRUSDR), and utilities</p>	<p>Available for download at: http://www.intel.com/p/en_US/support/highlights/server/s5520ur</p> <p>Click the “Software and Drivers” link on the left side of the web page.</p>
<p>To make sure your system falls within the allowed power budget</p>	<p>Power Budget Analysis Tool</p> <p>Available at: http://www.intel.com/p/en_US/support/highlights/server/s5520ur</p>
<p>For software to manage your Intel® server</p>	<p>Intel® System Management Software</p> <p>Available at: http://www.intel.com/go/servermanagement/</p>

2 Server System Features

This chapter briefly describes the main features of the server system. This chapter provides illustrations of the product, a list of the server system features, and diagrams showing the location of important components and connections on the server system.

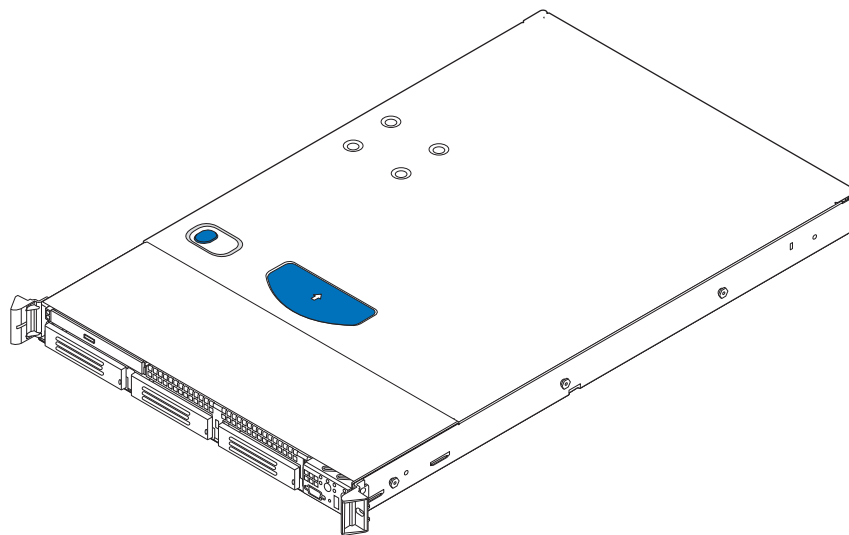

AF002746

Figure 1. Intel® Server System SR1600UR

Server System Feature Overview

Table 2 summarizes the features of the server system.

Table 2. Intel® Server System SR1600UR Feature Summary

Feature	Description
Dimensions	<ul style="list-style-type: none">• 1.703 inches (43.3 mm) high• 16.90 inches (430 mm) wide• 27.19 inches (690.6 mm) deep• 34 pounds (15.4 kg) - max chassis weight
Server Board	Intel® Server Board S5520UR
Processor	Support for one or two Intel® Xeon® Processors in FC-LGA 1366 Socket B package with up to 95 W Thermal Design Power (TDP) <ul style="list-style-type: none">• 4.8 GT/s, 5.86 GT/s and 6.4 GT/s Intel® QuickPath Interconnect (Intel® QPI)• EVRD11.1 For a complete list of supported processors, see http://www.intel.com/support/motherboards/server/s5520ur/compat.htm
Memory	<ul style="list-style-type: none">• Twelve DIMMs across six memory channels (three channels per processor)• Support for 800/1066/1333 MT/s ECC registered (RDIMM) or unbuffered (UDIMM) DDR3 memory
Chipset	<ul style="list-style-type: none">• Intel® 5520 Chipset I/O Hub• Intel® 82801Jx I/O Controller Hub

Table 2. Intel® Server System SR1600UR Feature Summary

Feature	Description
Peripheral Interfaces	<p>External connections:</p> <ul style="list-style-type: none"> • DB-15 video connector (back) • Hot-swap hard drive system only: DB-15 video connector (front) • RJ-45 serial Port A connector • Two RJ-45 10/100/1000 Mb network connections • Four USB 2.0 connectors (back) • One USB 2.0 connector (front) <p>Internal connections:</p> <ul style="list-style-type: none"> • One USB 2x5 pin header, which supports two USB 2.0 ports • One low-profile USB 2x5 pin header to support low-profile USB Solid State drives • One DH-10 Serial Port B header • Six Serial ATA (SATA) II connectors • Two I/O module connectors • One RMM3 connector to support an optional Intel® Remote Management Module 3 • SATA Software RAID 5 Activation Key connector • One SSI-EEB compliant front panel header • One SSI-EEB compliant 24-pin main power connector • One SSI-compliant 8-pin CPU power connector • One SSI-compliant auxiliary power connector
Video	<p>On-board ServerEngines* LLC Pilot II Controller</p> <ul style="list-style-type: none"> • Integrated 2D Video Controller • 32 MB DDR2 Memory
LAN	Two 10/100/1000 Intel® 82575 PHYs
Expansion Capabilities	One x16 PCI Express* Gen 2 PCI riser slot capable of supporting a full-length full-height PCI Express* add-in card
Hard Drive Options	<ul style="list-style-type: none"> • Fixed mount hard drive system: <ul style="list-style-type: none"> – Three SATA drives • Hot-swap hard drive system: <ul style="list-style-type: none"> – Three 3.5 inch hot-swap SATA/SAS drives • Intel® Embedded Server RAID Technology II with SW RAID levels 0/1/10 • Optional support for SW RAID 5 with activation key
Peripherals	<ul style="list-style-type: none"> • Slimline bay for slimline SATA optical drive • One PCI Express* X16 Add-in Card slot (Gen 2)
Control Panel	<ul style="list-style-type: none"> • Standard control panel • Hot-swap hard drive system only: Intel® Local Control Panel

Table 2. Intel® Server System SR1600UR Feature Summary

Feature	Description
LEDs and displays	<p>LEDs with standard control panel:</p> <ul style="list-style-type: none"> • NIC1 Activity • NIC2 Activity • Power/Sleep • System Status • System Identification • Hard Drive Activity <p>Intel® Light-Guided diagnostic LEDs:</p> <ul style="list-style-type: none"> • Fan Fault • DIMM Fault • CPU Fault • 5V-STBY • System Status • System Identification • POST Code Diagnostics
Power Supply	Single 600-W power supply
Fans	<ul style="list-style-type: none"> • Five 40x40x56-mm, non-redundant, variable-speed, dual-rotor system fans • Two non-redundant 40-mm power supply fans
System Management	<p>On-board ServerEngines* LLC Pilot II Controller</p> <ul style="list-style-type: none"> • Integrated Baseboard Management Controller (Integrated BMC), IPMI 2.0 compliant • Integrated Super I/O on LPC interface <p>Support for Intel® System Management Software</p>

Server System Components

This section helps you identify the components of your server system. If you are near the system, you can also use the Quick Reference Label provided on the inside of the chassis cover to assist in identifying components.

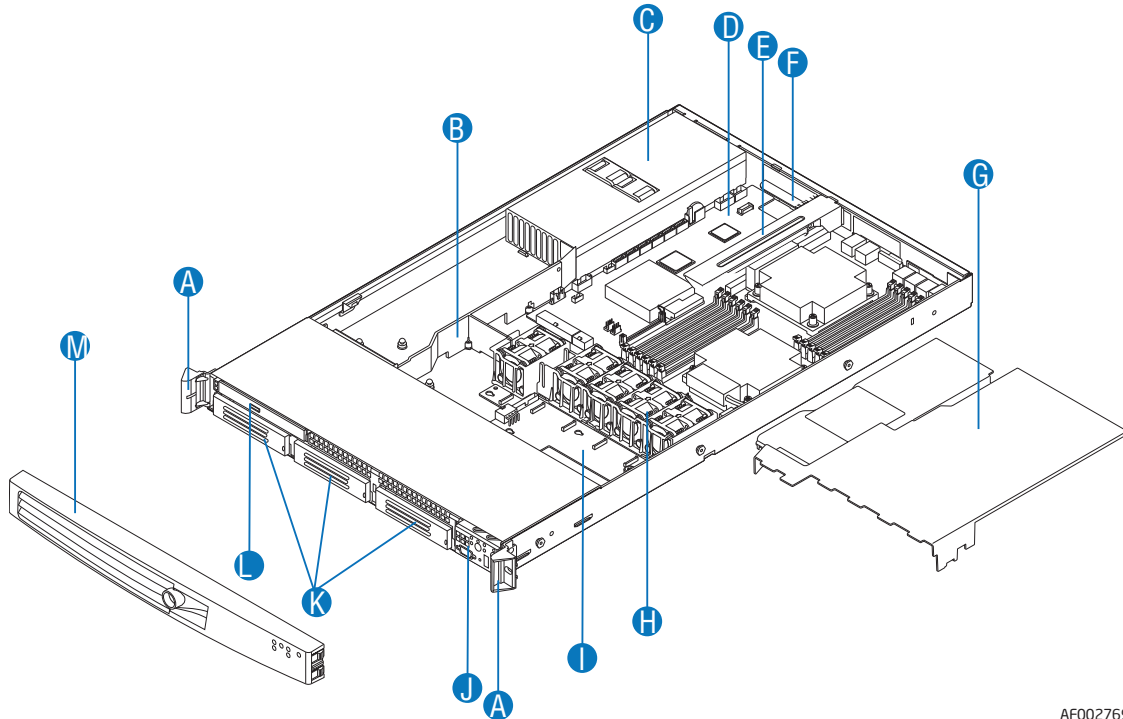

AF002769

A. Rack handles	H. System Fan Assembly
B. Air Baffle	I. Fan Board used in fixed mount hard drive system / Backpane used in hot-swap hard drive system
C. Power Supply	J. Control panel (standard control panel shown)
D. Server Board	K. Hard drive bays (drives not included): <ul style="list-style-type: none"> • Three fixed hard drives supported in fixed mount hard drive system • Three hot-swap drives supported in hot-swap hard drive system
E. PCI add-in riser assembly	L. Slimline Optical Drive Bay (drive not included)
F. PCI card bracket (full-height)	M. Front bezel (optional)
G. Processor air duct	

Figure 2. Server System Components

Intel® Light-Guided Diagnostics

The server system contains the following diagnostic LEDs, each providing the following functions:

- The System Status LED on the front and back panels (see [Figure 3](#) and [Figure 6](#)) shows the overall health of the system (green, blinking green, blinking amber, amber, off) .
- The System Identification LED on the front and back panel (see [Figure 3](#) and [Figure 6](#)) helps identify the server from among several servers. The ID LED is off by default, and blue when activated by button or software.
- DIMM Fault LEDs on the server board (see [Figure 3](#)) help identify failed and failing DIMM slots. The DIMM fault LEDs turn on (amber) if there is a DIMM fault.
- POST Code Diagnostic LEDs on the server board (see [Figure 3](#)) change color or state (off, green, red, amber) according to the POST sequence.
- The 5V-STBY LED on the server board (see [Figure 3](#)) is illuminated (green) when AC power is applied.
- Fan Fault LEDs on the fan board (in the fixed mount hard drive system - see [Figure 4](#)) or hot-swap backplane (in the hot-swap hard drive system - see [Figure 5](#)) help identify failed and failing fans. The fan fault LEDs turn on (amber) if there is a fan fault.

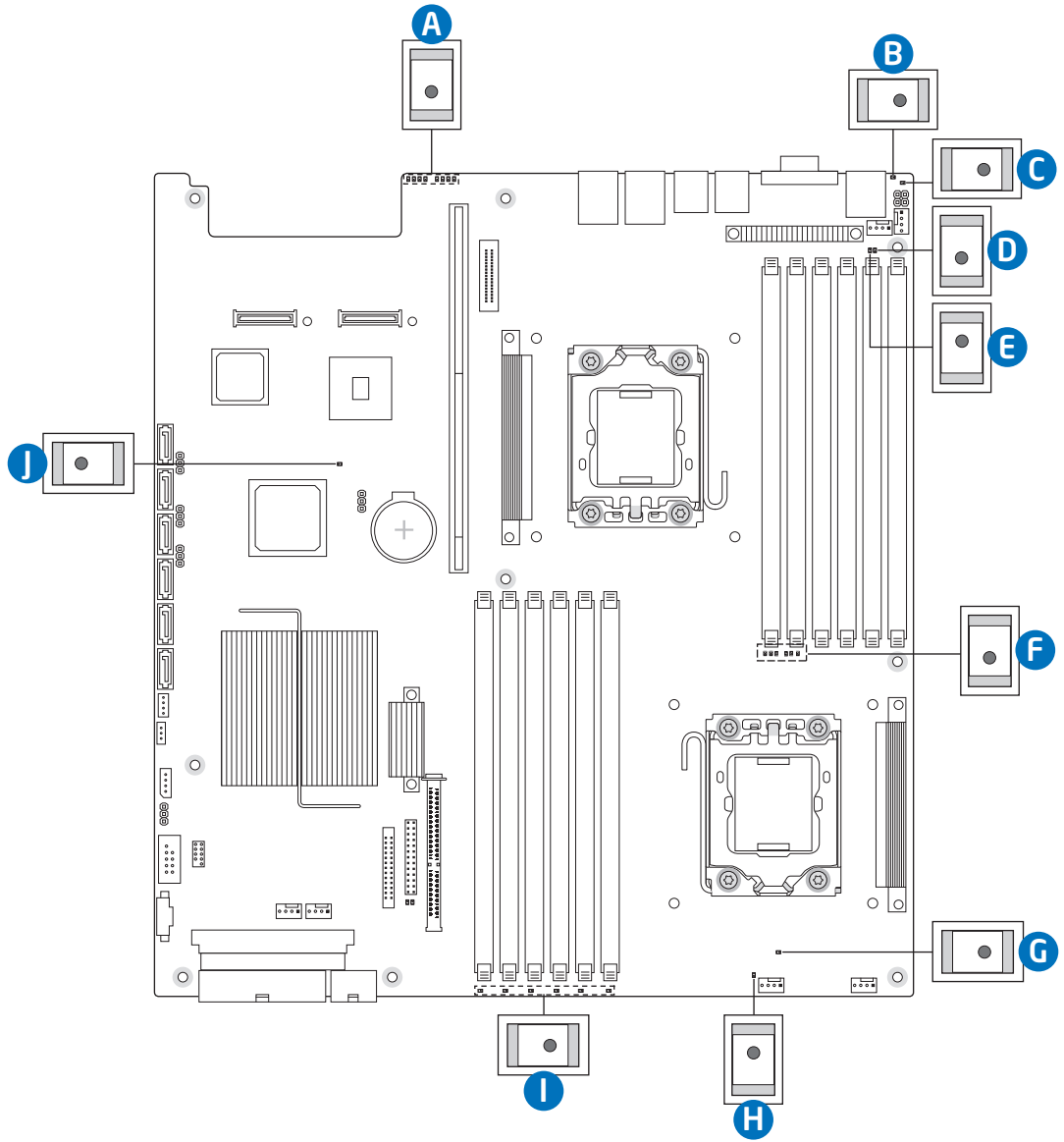

AF002833

A. POST Code Diagnostic LEDs	B. System Identification LED
C. Status LED	D. Memory 1 Fan Fault LED
E. CPU 1 Fan Fault LED	F. CPU 1 DIMM Fault LEDs
G. CPU 2 Fan Fault LED	H. Memory 2 Fan Fault LED
I. CPU 2 DIMM Fault LEDs	J. 5V Standby LED

Figure 3. Intel® Light-Guided Diagnostic LEDs - Server Board

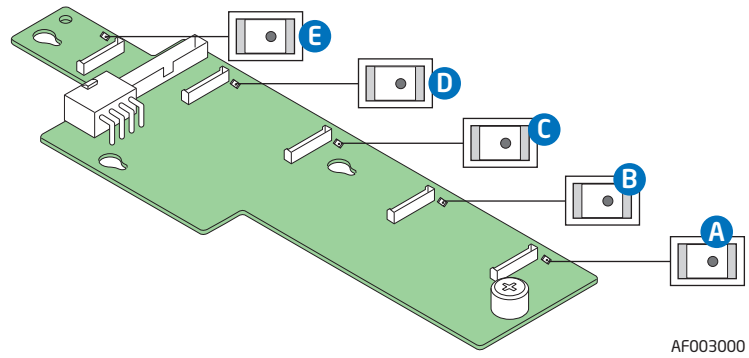

A. Fan 1 Fault LED	B. Fan 2 Fault LED
C. Fan 3 Fault LED	D. Fan 4 Fault LED
E. Fan 5 Fault LED	

Figure 4. Intel® Light-Guided Diagnostic LEDs - Fan Board

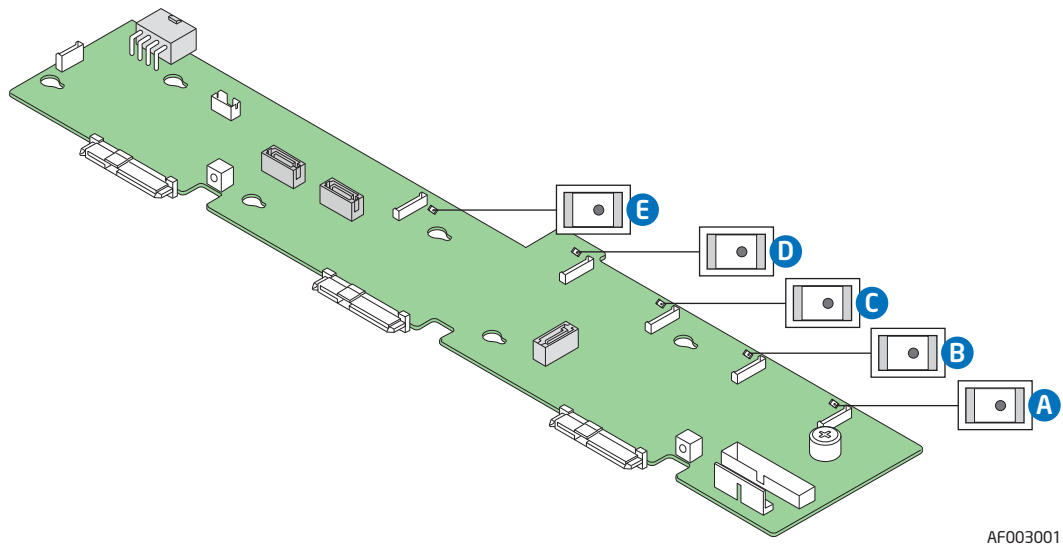

A. Fan 1 Fault LED	B. Fan 2 Fault LED
C. Fan 3 Fault LED	D. Fan 4 Fault LED
E. Fan 5 Fault LED	

Figure 5. Intel® Light-Guided Diagnostic LEDs - Hot-swap Backplane (Passive Shown)

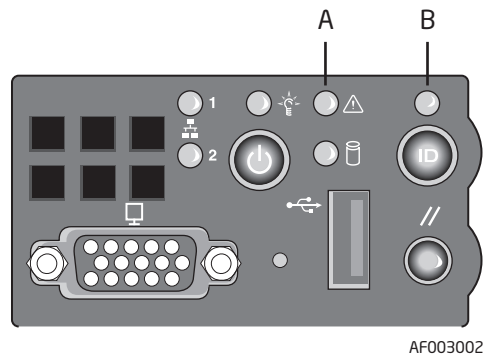

A. Status LED	B. System Identification LED
---------------	------------------------------

Figure 6. Intel® Light-Guided Diagnostic LEDs - Standard Control Panel

Server Board Components

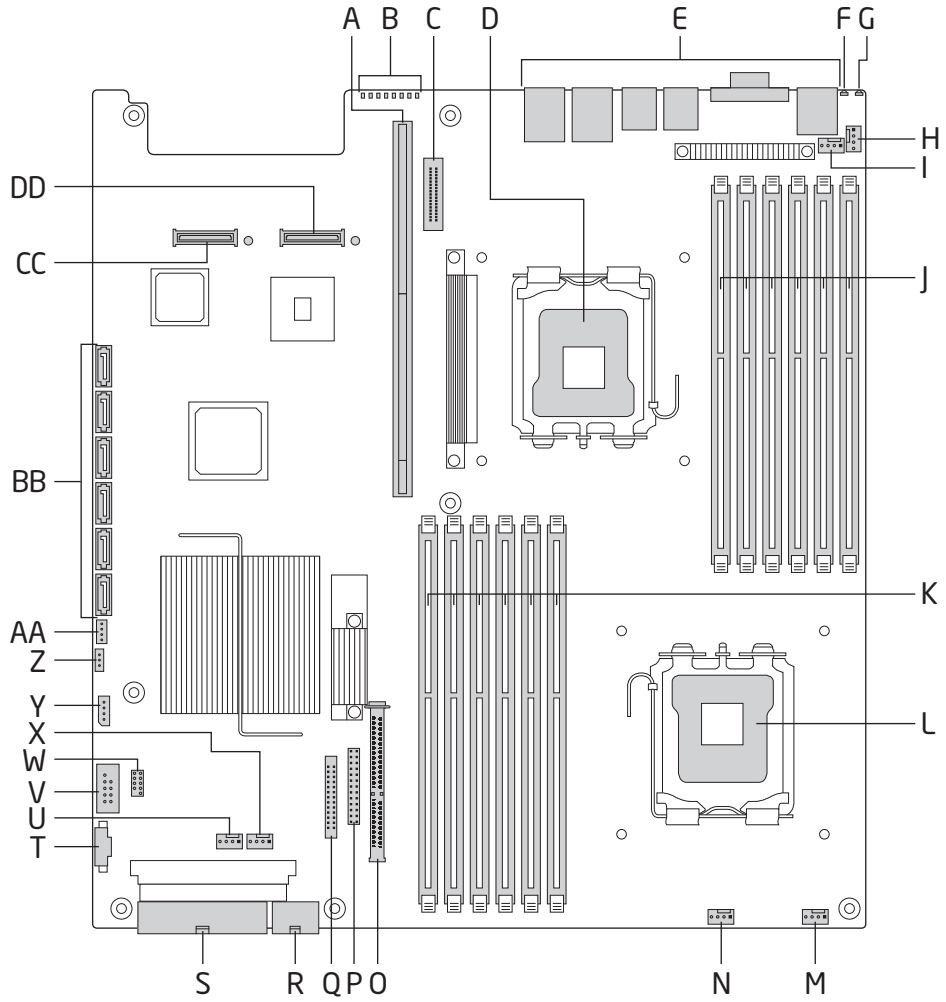

AF002696

A. 280-pin Intel® Adaptive Slot	B. POST Code Diagnostic LEDs	C. Intel® RMM3 Header
D. Processor 1 Socket	E. Back Panel I/O Ports	F. System Identification LED
G. System Status LED	H. Memory 1 Fan Header	I. Processor 1 Fan Header
J. Processor 1 DIMM slots	K. Processor 2 DIMM slots	L. Processor 2 Socket
M. Processor 2 Fan Header	N. Memory 2 Fan Header	O. Bridge Board Connector (Intel® Server Chassis)
P. Front Panel Connector	Q. Fan Board Connector	R. 2x4 Power Connector
S. Main Power Connector	T. Power Supply SMBus Connector	U. System 2 Fan Header
V. USB Header	W. Low-profile USB Solid State Drive Header	X. System 1 Fan Header
Y. LCP IPMB Header	Z. SATA RAID 5 Key Header	AA. SGPIO Header
BB. SATA Connectors	CC. I/O Module Mezzanine Connector 2	DD. I/O Module Mezzanine Connector 1

Figure 7. Server Board Connector and Component Locations

Configuration Jumpers

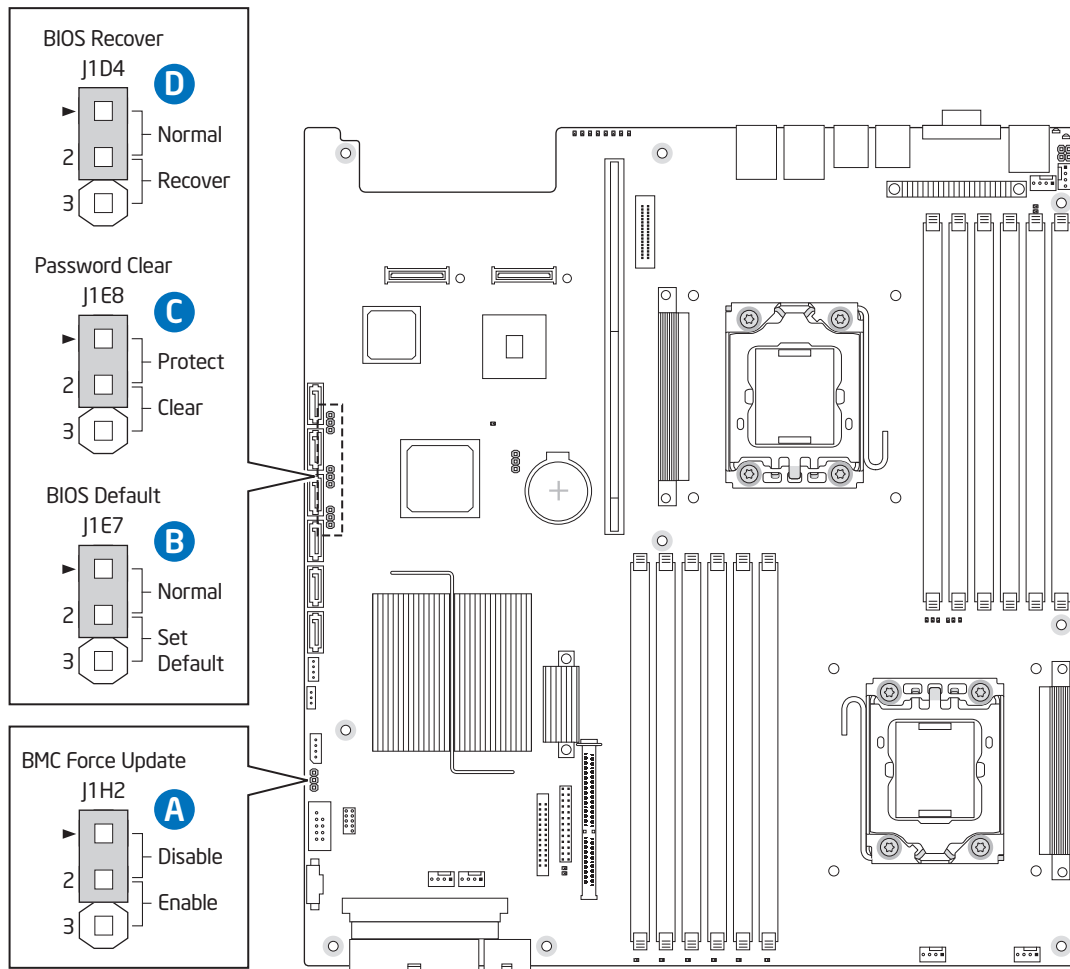

AF002832

	Jumper Name	Jumper Purpose
A.	BMC Force Update (J1H2)	If pins 2-3 are jumpered, the Integrated BMC Force Update Mode is enabled. These pins should be jumpered on 1-2 for normal system operation.
B.	BIOS Default (J1E7)	If pins 2-3 are jumpered, the BIOS settings are cleared on the next reset. These pins should be jumpered on 1-2 for normal operation.
C.	Password Clear (J1E8)	If pins 2-3 are jumpered, administrator and user passwords are cleared within five to ten seconds after the system is powered on. These pins should be jumpered on 1-2 for normal system operation.
D.	BIOS Recover (J1D4)	If pins 2-3 are jumpered, the system can only boot from EFI-bootable recovery media with the recovery BIOS image. The main system BIOS will not boot. These pins should be jumpered on 1-2 for normal system operation.

Figure 8. Configuration Jumpers

Front of Server System

Peripheral Devices

The server system provides locations and hardware for installing hard drives, a USB floppy drive (hot-swap hard drive systems only), and an optical drive. The drives must be purchased separately. The following figure shows the available options.

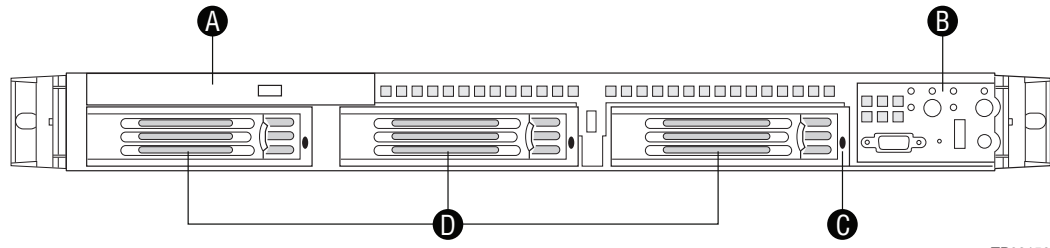

TP02156

A.	Slimline drive bay (drive not included)
B.	Control panel (Standard control panel shown)
C.	Hard Drive Status LEDs (hot-swap drives only)
D.	Hard drive bays (drives not included)

Figure 9. Optional Peripherals

Hard Disk Drive Carriers

The fixed mount hard drive server system (Product Code: SR1600UR) ships with three fixed mount drive carriers for installing three SATA hard drives.

The hot-swap hard drive server system (Product Code: SR1600URHS) ships with three hot-swap drive carriers for installing three SAS or Serial ATA (SATA) drives. The leftmost hard drive bay can be used to support a USB floppy drive this system. To use the bay for a floppy drive, the AXXUSBFLOPPY accessory kit must be used.

Note: *The USB floppy drive kit is supported on the Intel[®] Server System SR1600UR (Product Code: SR1600URHS) only.*

For instructions on installing hard drives, see the following sections:

- [“Installing and Removing a Fixed Mount Hard Drive \(Fixed Mount Hard Drive System Only\)” on page 57](#)
- [“Installing and Removing a Hot-swap Hard Drive \(Hot-swap Hard Drive System Only\)” on page 61](#)

Note: *Drives can consume up to 17 watts of power each. Drives must be specified to run at a maximum ambient temperature of 45C.*

Note: *The Intel[®] Server System SR1600UR does not support all SAS or Serial ATA (SATA) hard drives. For a list of supported hard drives, use the Server Configurator Tool. For a web link to this tool, see [“Additional Information and Software” on page 3](#).*

Slimline Optical Drive Carrier

The system includes a slimline optical drive carrier, which can be used to install an optional SATA optical drive. The optical drive must be purchased separately. You cannot install both an optical drive and a USB floppy drive.

The slimline optical drive carrier can be inserted or removed only when system power is turned off. Drive in the optical drive carrier is NOT hot swappable. For installation instructions on installing an optical drive or USB floppy, see [“Installing and Removing a Slimline Optical Drive or Internal USB Floppy” on page 63](#).

To use one of the drives provided by Intel, use the following order codes:

- Slimline DVD-ROM Drive: AXXSATADVDRM
- Slimline DVD-RW Drive: AXXSATADVDRWROM

Note: *The Intel[®] Server System SR1600UR does not support all slimline optical drives. For a list of supported slimline optical drives, use the Server Configurator Tool. For a web link to this tool, see [“Additional Information and Software” on page 3](#). Intel provides accessory kits for these drives.*

Control Panel

The Intel® Server System SR1600UR supports the following types of control panels:

- Standard Control Panel
- Intel® Local Control Panel (hot-swap hard drive systems only)

Standard Control Panel

The following diagram identifies the features available on the standard control panel. For instructions on installing the standard control panel, see [“Replacing the Control Panel Module \(Hot-swap Hard Drive System only\)”](#) on page 88.

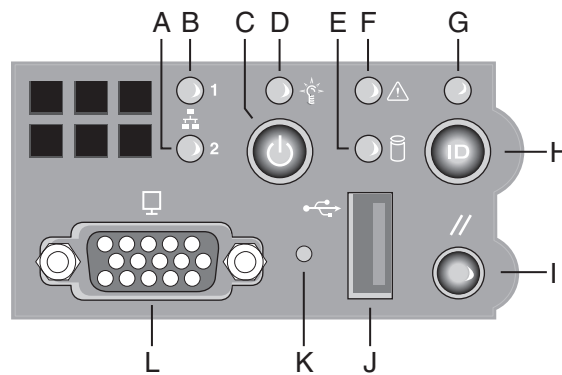

TP02160

Callout	Feature	Function
A. B.	NIC 2 Activity LED NIC 1 Activity LED	Continuous green light indicates a link between the system and the network to which it is connected. Blinking green light indicates network activity.
C.	Power/Sleep Button	Powers on/off the system. If enabled by an ACPI-compliant operating system, this button functions as a Sleep button and puts the system in an ACPI sleep state.
D.	Power/Sleep LED	Continuous green light indicates the system has power applied to it or the system is in ACPI S0 state. Blinking green indicates the system is in sleep or ACPI S1 state. No light indicates the power is off or the system is in ACPI S4 or S5 state.
E.	Hard Disk Drive Activity LED	Random blinking green light indicates hard disk drive activity (SAS or SATA). No light indicates no hard disk drive activity.

Callout	Feature	Function
F.	System Status LED	Solid green indicates normal operation. Blinking green indicates degraded performance. Solid amber indicates a critical or non-recoverable condition. Blinking amber indicates a non-critical condition. No light indicates POST is running or the system is off.
G.	System Identification LED	Solid blue indicates system identification is active. No light indicates system identification is not activated.
H.	System Identification Button	Turns on/off the system identification LED.
I.	Reset Button	Reboots and initializes the system.
J.	USB Port	Allows you to attach a USB component to the front of the system.
K.	NMI Button	Puts the server in a halt-state for diagnostic purposes and allows you to issue a non-maskable interrupt. After issuing the interrupt, a memory download can be performed to determine the cause of the problem.
L.	Video Port	Allows you to attach a video monitor to the front of the system. The front and rear video ports cannot be used at the same time. NOTE: The video port option is only available on the hot-swap hard drive system (Product Code: SR1600URHS).

Figure 10. Standard Control Panel

Intel® Local Control Panel

The following diagram identifies the features available on the Intel® Local Control Panel.

Note: The Intel® Local Control Panel is only supported in the hot-swap hard drive system (Product Code: SR1600URHS).

For instructions on installing the standard control panel, see “[Replacing the Control Panel Module \(Hot-swap Hard Drive System only\)](#)” on page 88.

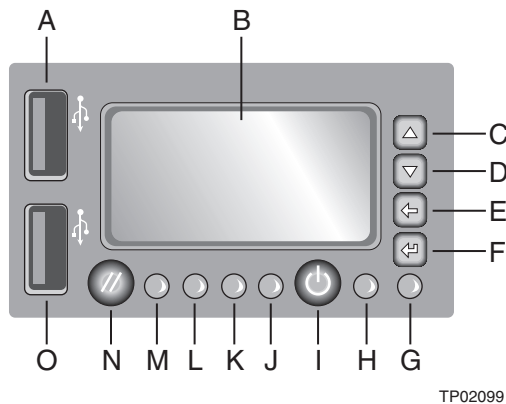

TP02099

Callout	Feature	Function
A.	USB Port	Allows you to attach a USB component to the front of the system.
B.	LCD Display	Screen on which system information is displayed.
C.	Menu Control Button, Scroll Up	Scroll up one option at a time.
D.	Menu Control Button, Scroll Down	Scroll down one option at a time.
E.	Menu Control Button, Scroll Left	Move to the previous option.
F.	Menu Control Button, Enter	Select option.
G.	System Identification LED	Solid blue indicates system identification is active. No light indicates system identification is not activated.
H.	Power/Sleep LED	Continuous green light indicates the system has power applied to it or the system is in S0 state. Blinking green indicates the system is in sleep or ACPI S1 state. No light indicates the power is off or the system is in ACPI S4 or S5 state.
I.	Power/Sleep Button	Powers on/off the system. If enabled by an ACPI-compliant operating system, this button functions as a Sleep button and puts the system in an ACPI sleep state.
J.	System Status LED	Solid green indicates normal operation. Blinking green indicates degraded performance. Solid amber indicates a critical or non-recoverable condition. Blinking amber indicates a non-critical condition. No light indicates POST is running or the system is off.
K. L.	NIC 2 Activity LED NIC 1 Activity LED	Continuous green light indicates a link between the system and the network to which it is connected. Blinking green light indicates network activity.
M.	Hard Disk Activity LED	Random blinking green light indicates hard disk drive activity (SAS or SATA). No light indicates no hard disk drive activity.
N.	Reset Button	Reboots and initializes the system.
O.	USB Port	Allows you to attach a USB component to the front of the system.

Figure 11. Intel® Local Control Panel

Bezels

The optional front bezels provide a snap-on design that allows for maximum airflow through the server system. Two bezels are available. One fits a system that has the standard control panel installed (with or without a video port). The other is used only in a hot-swap hard drive system with the Intel® Local Control Panel installed.

Each bezel provides a lock to secure the hard drive and optical drive area. For instructions on installing either of the front bezels, see [“Installing the Front Bezel” on page 37](#).

The order numbers for the bezels are:

- ADWBEZBLACK: Black bezel for use with the standard control panel.
- ADWLCDBEZEL: Black bezel for use with the Intel® Local Control Panel.

Rear of Server System

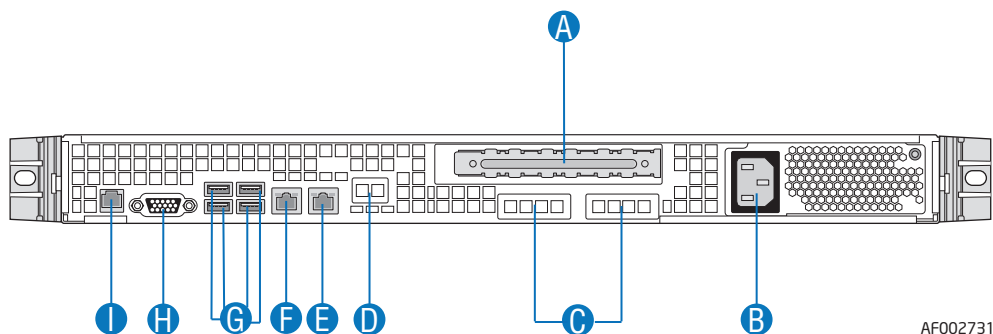

A. Add-in card bracket (full-height)	F. NIC 2 connector
B. AC Power Receptacle	G. Four USB 2.0 connectors
C. IO module external connector (optional)	H. Video connector
D. Management Network Interface (optional)	I. RJ-45 serial B port connector
E. NIC 1 connector	

Figure 12. Server System Back Panel

Back Panel Connectors

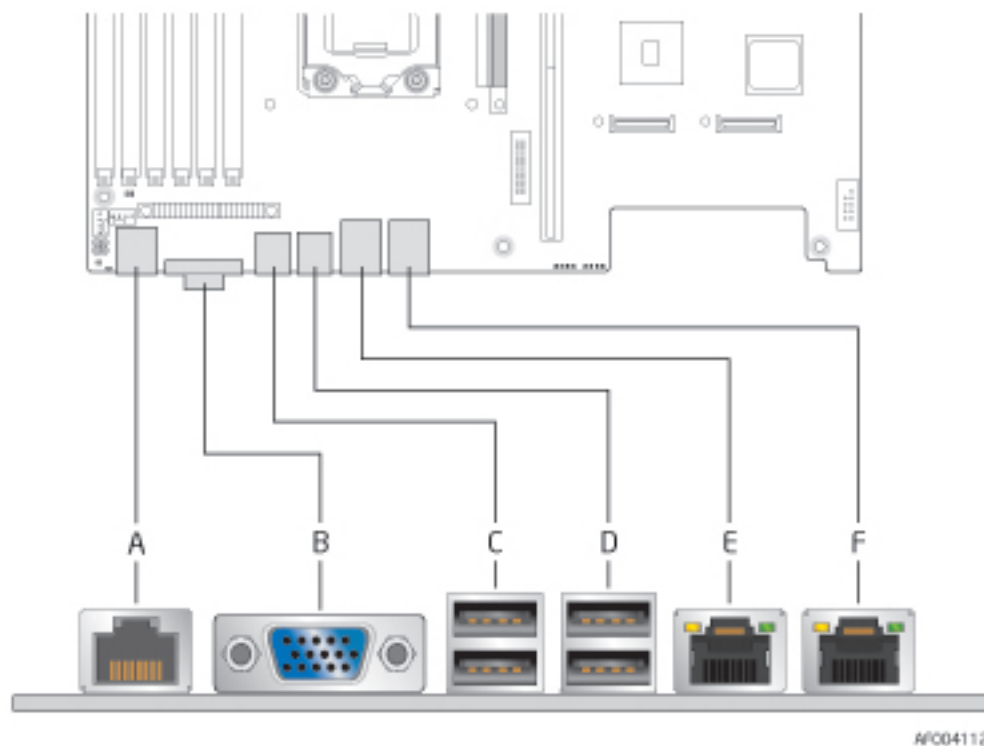

A. Serial Port A (RJ-45)	B. Video
C. USB Ports 0 and 1	D. USB Ports 2 and 3
E. NIC 1 (10/100/1000 Mb)	F. NIC 2 (10/100/1000 Mb)

Figure 13. Back Panel Connectors

The NIC LEDs at the right and left of each NIC provide the following information.

Table 3. NIC LED Descriptions

LED	LED State	Description
Left	Off	No network connection
	Solid Amber	Network connection in place
	Blinking Amber	Transmit/receive activity
Right	Off	10 Mbps connection (if left LED is on or blinking)
	Solid Amber	100 Mbps connection
	Solid Green	1000 Mbps connection

SAS/SATA Backplanes

The hot-swap hard drive system (Product Code: SR1600URHS) can support either an active SAS (Product Order Code: ASR1500SASBP) or a passive SAS/SATA backplane (Product Order Code: ASR1500PASBP). The backplanes provide the platform support for peripheral drives and hot-swap SAS or SATA hard drives. To eliminate several cables, the backplanes are also used as a pathway for signals from the server board to various platform interconnects, including those for the control panel and peripheral drives.

Active Backplane

The active backplane has a built-in SAS controller that does not need communication with the baseboard controller or an add-in card. The following diagram shows the location for each connector found on the active backplane.

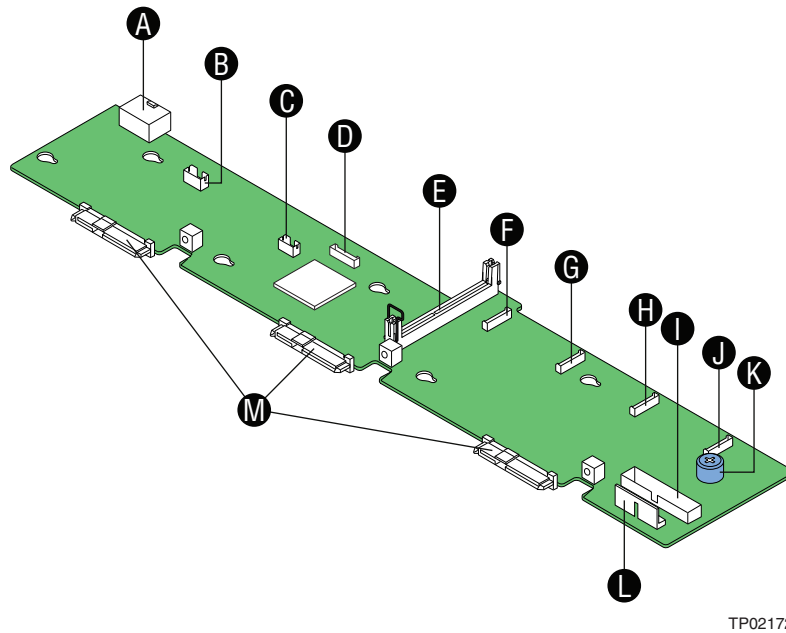

TP02172

A. Backplane Power	H. Fan 2 Power
B. USB Floppy Connector	I. Front Panel Connector
C. SW RAID Activation Key	J. Fan 1 Power
D. Fan 5 Power	K. Screw
E. Bridge Board Connector	L. Front Panel USB
F. Fan 4 Power	M. Hot-swap SAS/SATA Connectors
G. Fan 3 Power	

Figure 14. Active SAS Backplane Components

Passive Backplane

The passive backplane acts as a 'pass-through' for the SAS/SATA data from the drives to the SATA controller on the server board or a SAS/SATA controller add-in card. It provides the physical requirements for the hot-swap capabilities. The following diagram shows the location for each connector found on the passive backplane.

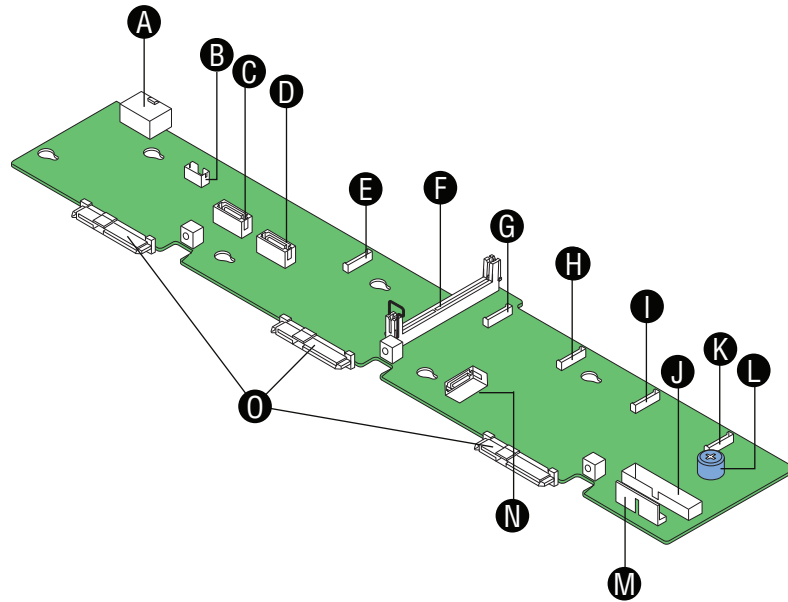

AF002999

A. Backplane Power	I. Fan 2 Power
B. USB Floppy Connector	J. Front Panel Connector
C. SATA 0	K. Fan 1 Power
D. SATA 1	L. Screw
E. Fan 5 Power	M. Front Panel USB
F. Bridge Board Connector	N. SATA 2
G. Fan 4 Power	O. Hot-swap SAS/SATA Connectors
H. Fan 3 Power	

Figure 15. Passive SAS/SATA Backplane Components

RAID Support

The server system provides an embedded SATA controller on the server board that is accessible through the passive backplane. The SATA controller supports both 1.5 and 3.0 Gbps data transfer rates.

The BIOS Setup utility provides multiple drive configuration options on the Advanced | ATA Controller setup page, some of which affect the ability to configure RAID. The Onboard SATA Controller option is enabled by default. When this option is enabled, the SATA Mode option can be set to either Legacy or Enhanced. The Legacy and Enhanced modes affect the RAID configuration as follows:

- Legacy supports four disk drives and does not provide RAID support.
- Enhanced supports six disk drives and is required for RAID configurations.

When the enhanced mode is selected, you can choose to enable or disable “AHCI Mode” or “Configure SATA as RAID”. The Intel® Embedded Server RAID Technology II is enabled by the “Configure SATA as RAID” option. The Intel® Embedded Server RAID Technology II feature provides RAID modes 0, 1, and 10.

For RAID 0, 1, and 10, enclosure management is provided over the bridge board.

If RAID 5 is desired, the optional Intel® RAID Activation Key AXXRAKSW5 can be installed. To enable RAID 5, this activation key is placed on the SATA Key connector that is located at the left side of the server board.

For information on configuring RAID, see the *Intel® RAID Software User's Guide* that is included on the *Intel® Server Deployment Toolkit 3.0 CD*.

Advanced Management Options

Intel® Remote Management Module 3

The Intel® Remote Management Module 3 plugs into a dedicated connector on the server board and provides additional server management functionality to the server board.

This module provides a dedicated web server for viewing server information and remote control of the system. It also provides Remote KVM Redirection and USB Media Redirection allowing USB devices attached to the remote system to be used on the managed server.

For instructions on installing the Intel® Remote Management Module 3, see [“Installing and Removing the Intel® Remote Management Module 3” on page 70](#).

Rack Mount Options

Your Intel® Server System SR1600UR can be mounted into a rack. Intel provides the following three options to mount this server system into a rack:

- Fixed mount relay rack/cabinet mount kit: This kit can be configured to mount the system into either a 2-post rack or 4-post cabinet.
- Tool-less sliding rail kit: This kit is used to mount the system into a standard (19 inches by upto 30 inches deep) EIA-310D compatible server cabinet. An optional cable management arm can be used with this kit.
- Basic three-quarter extension sliding rail kit: This kit is used to mount the system into a standard (19 inches by upto 30 inches deep) EIA-310D compatible server cabinet.

When installing the system into a rack, Intel recommends you install systems from the bottom of the rack to the top. In other words, install the first system in the rack into the bottom position of the rack, the second system in the second position from the bottom, and so on. For instructions on installing your system into a rack, see [“Removing and Installing from a Rack” on page 33](#). These instructions are also included in each rackmount option kit.

3 Hardware Installations and Upgrades

Before You Begin

Before working with your server product, pay close attention to the “[Safety Information](#)” on [page v](#) at the beginning of this manual.

***Note:** Whenever you service the system, you must first power down the server and unplug all peripheral devices and the AC power cord.*

Tools and Supplies Needed

- Phillips* (cross head) screwdrivers (#1 bit and #2 bit)
- Needle nosed pliers
- Antistatic wrist strap and conductive foam pad (recommended)

System References

All references to left, right, front, top, and bottom assume the reader is facing the front of the server system as it would be positioned for normal operation.

Cable Routing

When you add or remove components from your server system, make sure your cables are routed correctly before reinstalling the server system cover. Use caution to make sure no cables or wires are pinched and that the airflow from the fans is not blocked. Use the figures below to determine the correct cable routing.

Fixed Mount Hard Drive System

Use the following figure to determine the correct cable routing for a fixed mount hard drive system.

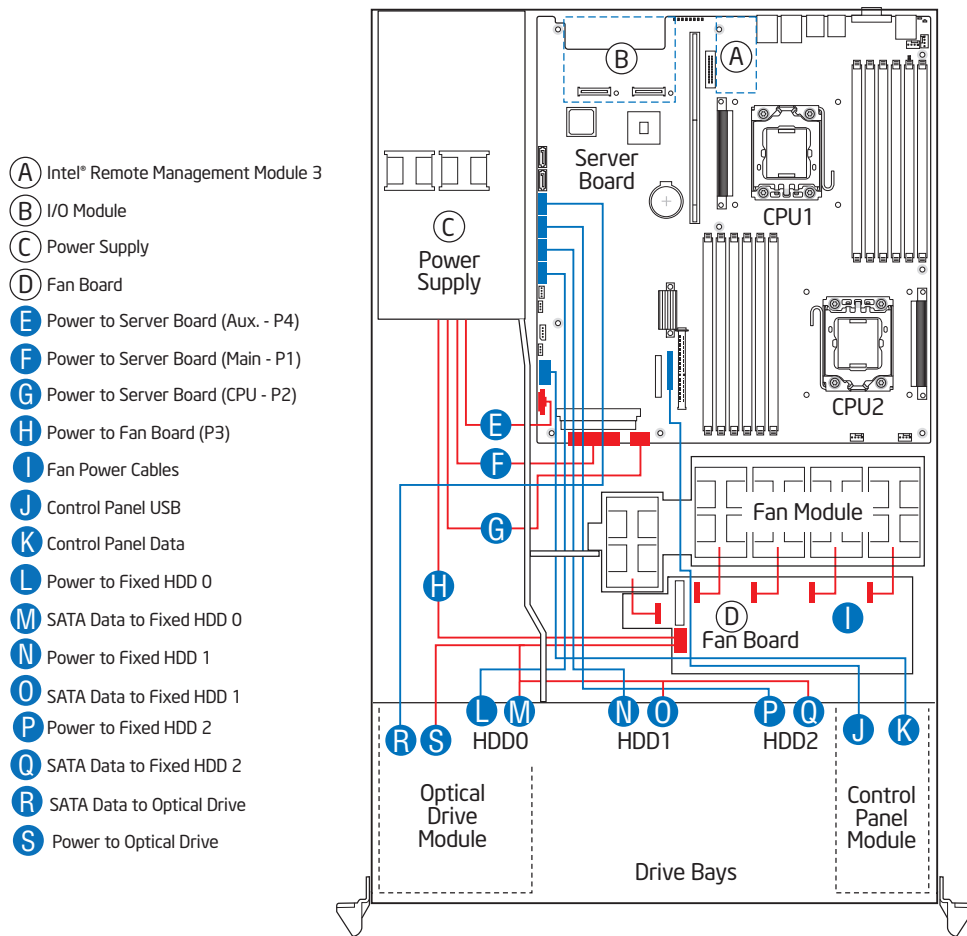

AF002876

Figure 16. Cable Routing (Fixed Mount Hard Drive System)

Cabling Around the Small Air Baffle

In a fixed mount hard drive system, route the following cables through the air baffle notches (as shown in Figure 17):

- Main Power Cable
- CPU Power Cable
- Power Signal Cable
- Optical Drive Data Cable
- SATA 0-2 HDD Data Cables
- SATA 0-2 HDD Power Cables

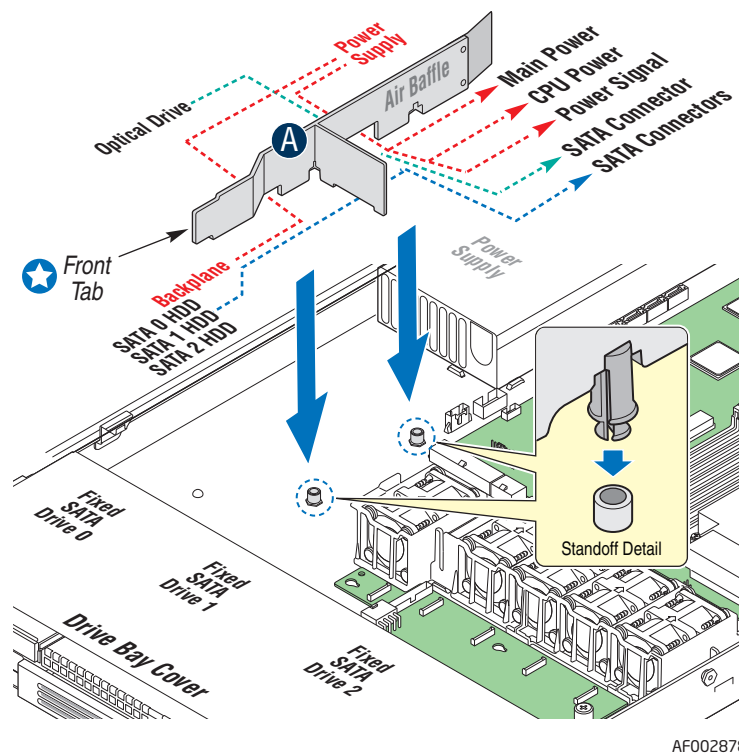

AF002878

Figure 17. Cabling Around the Small Air Baffle (Fixed Mount Hard Drive System)

Hot-swap Hard Drive System

Use the following figure to determine the correct cable routing for a hot-swap hard drive system.

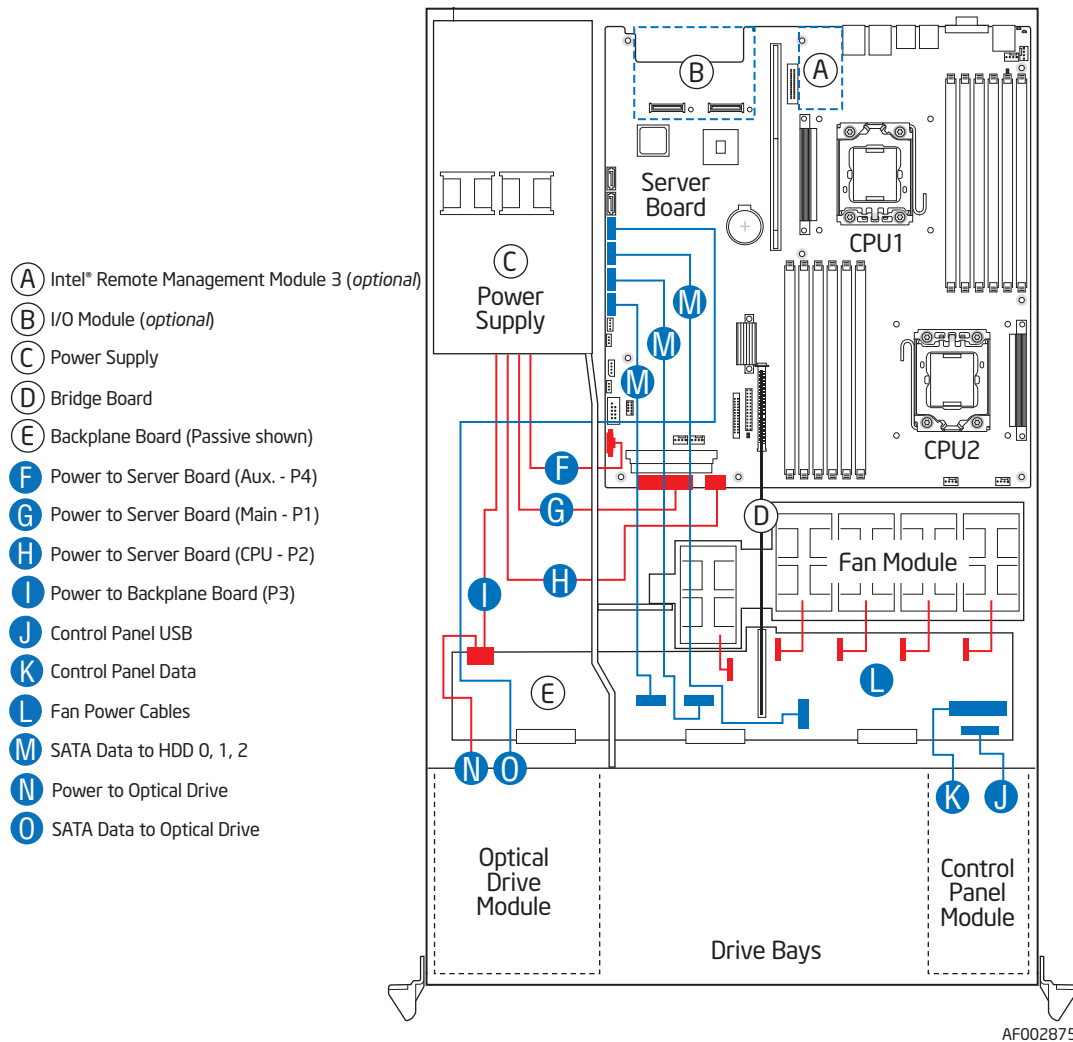

Figure 18. Cable Routing (Hot-swap Hard Drive System)

Cabling Around the Small Air Baffle

In a hot-swap hard drive system, route the following cables through the air baffle notches (as shown in Figure 19):

- Main Power Cable
- CPU Power Cable
- Power Signal Cable

- Optical Drive Data Cable
- SATA 0-2 HDD Data Cables (passive backplane only)

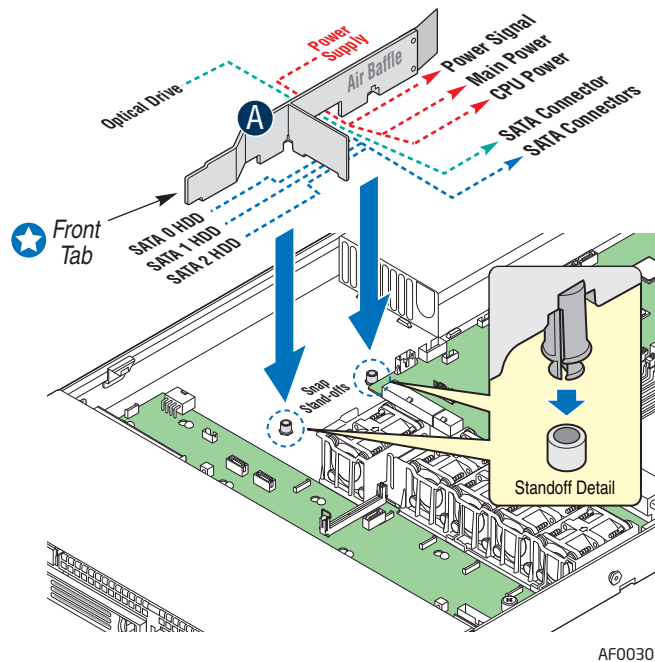

Figure 19. Cabling Around the Small Air Baffle (Hot-swap Hard Drive System)

Removing and Installing from a Rack

To install the Intel® Server System SR1600UR in a rack, three Intel® rack options are available:

- Fixed mount relay rack/cabinet mount kit
This rack option requires the system to be removed from the rack before servicing.
- Basic sliding rail kit
This rack option requires the system to be removed from the rack before servicing.
- Tool-less sliding rail kit
Only the tool-less rail kit allows you to service the server system while installed in a rack.

Note: Follow all safety guidelines while removing a system from a rack to avoid injury.

Fixed Bracket Rack Mount Removal

1. Disconnect all cables from the back of the system.

Note: Remember to use the system LED to properly identify the system you are servicing.

2. Remove screws from the brackets and remove the system from the rack.

Fixed Bracket Rack Mount Installation

1. Fully extend a rail assembly; the finger tab for the extension lock is revealed.
2. Press the finger tab and slide the inside rail from the middle rail until it completely separates.

Note: The middle rail and outer rail cannot be separated.

3. Position an inside rail along one side of the chassis with the finger tab facing outward and located closer to the rear of the chassis.
4. Align the holes in the rail with the tabs on the chassis and place the rail against the chassis.
5. Slide the rail as far as it will go toward the front of the chassis to engage the tabs.
6. Fasten the rail to the chassis using one screw at the front of the chassis.
7. In the same manner, attach the other inside rail to the other side of the chassis.
8. Using two screws, attach one nut bar to the inside of the rack post. Do not completely tighten the screws; leave them loose enough to allow insertion of the brackets in the next step.
9. Insert the slotted foot of a rail bracket between each nut bar and post.
10. Align the face of the bracket foot with the inside edge of the rack post and firmly tighten the screws.
11. Repeat steps 8 to 10 above to install the other 3 brackets (2 front & 2 back). Ensure all brackets are at the same height on the rack.
12. Position a rail assembly (middle and outer rails) with its black plastic end caps toward the rear of the rack and its outer rail closest to the brackets.
13. Align the front screw hole in the outer rail with the threaded hole nearest the front of the front bracket and fit the rail assembly into the front and rear brackets.
14. Slide the middle rail toward the front until the access hole in the middle rail is aligned with the front screw hole in the outer rail.
15. Insert screw through the access hole and loosely attach the outer rail to the front bracket.
16. In a similar manner to steps 13 through 15, install a screw through a slot in the outer rail and into the rear-most threaded hole in the front bracket. Firmly tighten this screw.
17. Firmly tighten the front screw installed loosely in step 15.

18. In the same manner, attach the other rail assembly to the other side.
19. Slide the middle rail toward the front until the rear bracket area is accessible.
20. Attach the rear end of the outer rail to the rear bracket with at least one screw. If possible, attach at two places.
21. In the same manner, attach the other rail assembly to the other side.
22. Fully extend the left and right rails until the extension locks have engaged and the rails will not push back in. The rail system is now ready to receive the chassis.

Caution: *Lifting and placing the chassis in the rails is a two-person job. If needed, use an appropriate lifting device.*

23. With the chassis front facing you, lift the chassis and carefully insert the rails attached to the chassis in the extended rails.
24. Slide the chassis toward the rear of the cabinet until the rails lock together.
25. Depress and hold down the finger tabs on both extension locks while sliding the chassis toward the rear.
26. Slide the chassis all the way into the rack until the chassis handles are against the front posts.

Basic Rail Rack Mount Removal

1. Disconnect all cables from the back of the system.

Note: *Remember to use the system LED to properly identify the system you are servicing.*

2. Pull system from rack until brackets are fully extended.
3. Push in both clips on the brackets and slide the system forward until the inner rail separates from the outer rail.
4. Remove and service the system.

Basic Rail Rack Mount Installation

1. Extend the inner rail until it locks.
2. Depress the spring safety lock to release the inner rail.
3. Remove the inner rail from the rail assembly.
4. Attach the outer rail slides to the rack posts using two #10-32 x 1/2 screws at the front posts, and two #10-32 x 1/2 screws at the rear posts.

Note: *The rail flanges mount to the inside of each post.*

5. Insert the inner rails over the server chassis sidewall studs.
6. Slide the inner rails toward the front of the server chassis.
7. Secure the inner rails with one #6-32 x 1/4 screw for each rail.

8. Align the inner rails (attached to the server chassis) with the outer rail assemblies (attached to the rack).
9. Engage the matching rails and slide the server chassis into the rack until the two safety stops lock into position.
10. Depress the two safety locks (one on each side).
11. Slide the server chassis all the way into the rack.
12. Use the rack screws (#10-32 x 3/4) to secure the chassis and rack handles into the rack.

Tool-less Rail Rack Mount Servicing

1. To service the system, pull the system out from the rack.
2. Disconnect the power cable(s) and proceed with servicing the system.
3. When the servicing is completed, re-connect the power cable(s).
4. Pull up on the green tabs on each rail and slide the system back into the rack.

Note: *Beware of cables when re-installing the system into the rack so that the cables do not get pulled or interfered with.*

Installing and Removing the Front Bezel

The front bezels are available as optional accessories for the Intel® Server System SR1600UR. The following front bezel options are available:

- Bezel for use with the Standard Control Panel (Product Order Code: ADWBEZBLACK)
- Bezel for use with the Intel® Local Control Panel (Product Order Code: ADWLCDBEZEL)

To identify your bezel, see the following figures. Note the orientation in the figures below - the control panel is at the right. If you are installing a bezel on your server system, make sure you position it as shown.

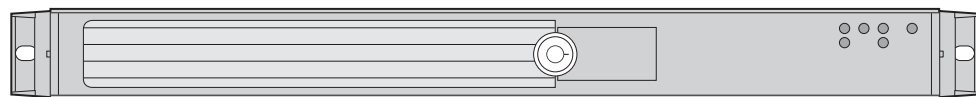

TP02197

Figure 20. Front View with Bezel supporting the Standard Control Panel

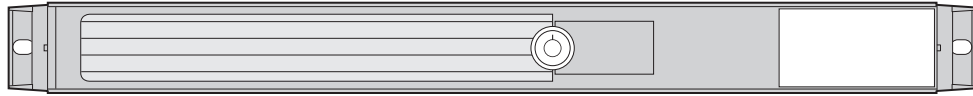

TP02198

Figure 21. Front View with Bezel supporting the Intel Local Control Panel

Installing the Front Bezel

Before installing the bezel, you must install the rack handles. For instructions, see “Installing the Rack Handles” on page 94.

To install the front bezel, follow these steps:

1. At each end of the bezel, line up the center notch on the bezel with the center guide on the rack handles.
2. Push the bezel onto the front of the server system until it clicks into place.

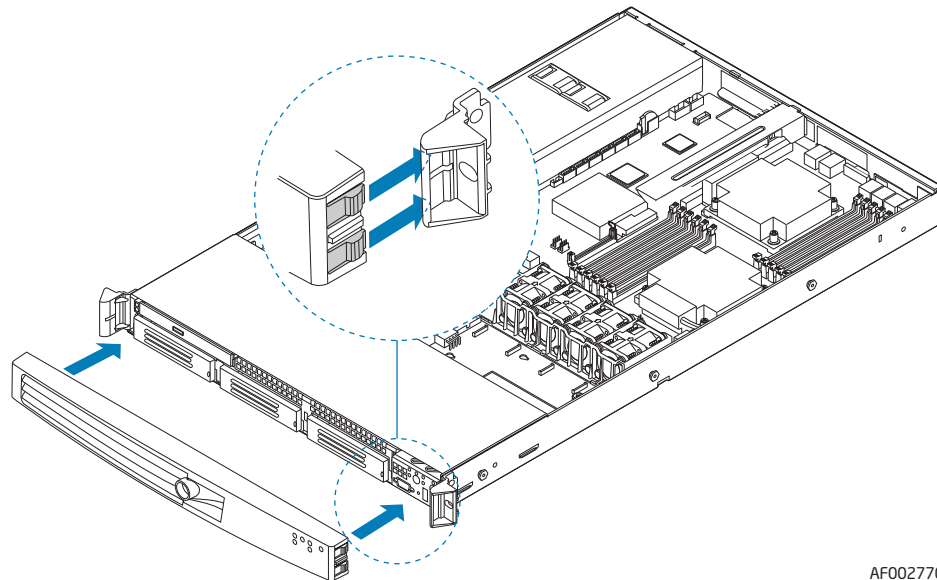

AF002770

Figure 22. Installing the Front Bezel

Removing the Front Bezel

To remove the front bezel, follow these steps:

1. Unlock the bezel.
2. Pull the bezel from the server system.

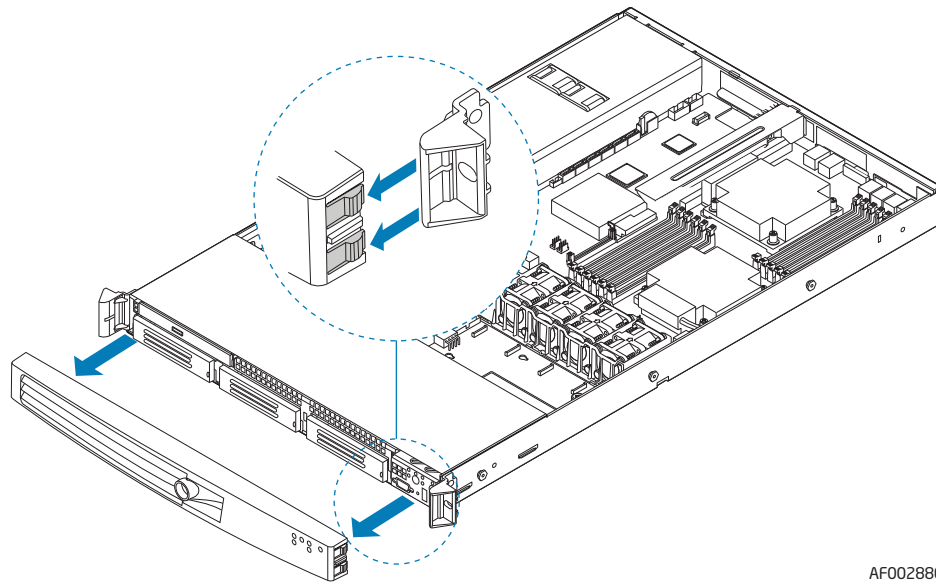

AF002880

Figure 23. Removing the Front Bezel

Removing and Installing the System Cover

Removing the System Cover

The server system must be operated with the system cover in place to ensure proper cooling. You will need to remove the top cover to add or replace components inside of the server. Before removing the system cover, power down the server and unplug all peripheral devices and the AC power cable(s).

Note: A nonskid surface or a stop behind the server system may be needed to prevent the server system from sliding on your work surface.

To remove the server system cover, follow these steps:

1. Remove the safety screw if it is installed (see letter "A" in [Figure 24](#)).
2. While holding in the blue button at the top of the server system in (see letter "B" in [Figure 24](#)), slide the top cover back until it stops (see letter "C" in [Figure 24](#)).
3. Insert your finger in the notch (see letter "D" in [Figure 24](#)) and lift the cover upward to remove it.

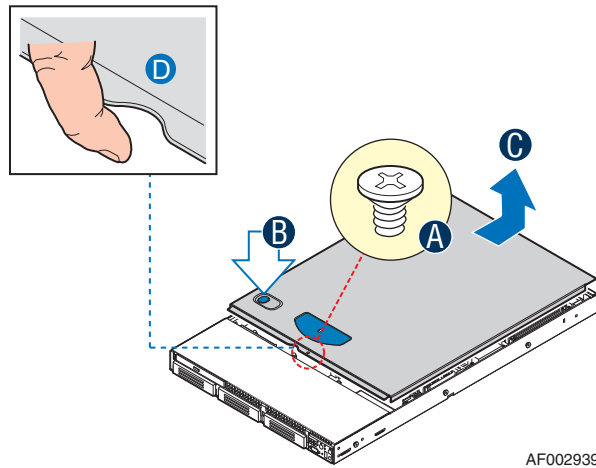

AF002939

Figure 24. Removing the Server System Cover

Installing the System Cover

To install the server system cover, follow these steps:

1. Place the cover over the server system so that the side edges of the cover sit just inside the server system sidewalls.
2. Slide the cover forward until it clicks into place (see letter “A” in [Figure 25](#)).
3. (Optional) Insert the safety screw at the center of the top cover (see letter “B” in [Figure 25](#)) if required.

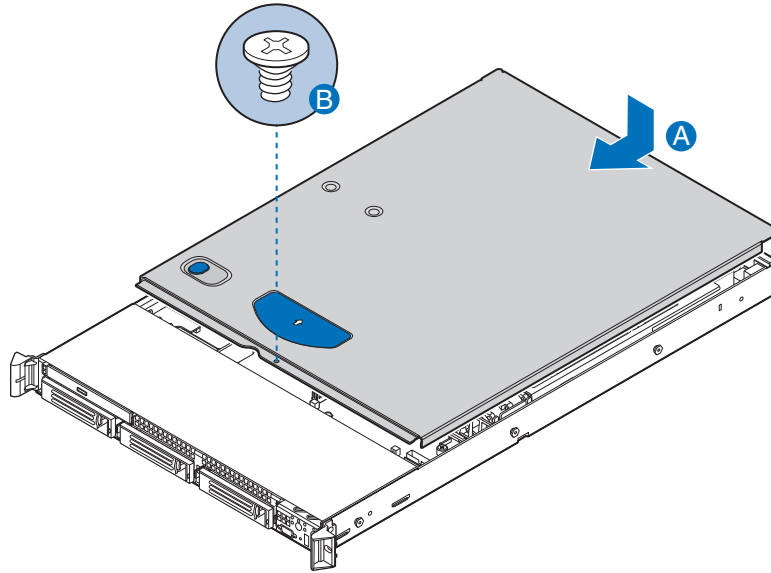

TP02196

Figure 25. Installing the Server System Cover

Removing and Installing the PCI Riser Assembly

Removing the PCI Riser Assembly

To remove the PCI riser assembly, follow these steps:

1. Disconnect any cables attached to any add-in cards.
2. Grasp both riser latches with thumb and forefinger (see letter “A” in [Figure 26](#)), and pull up to release riser assembly.
3. Lift riser assembly straight up (see letter “B” in [Figure 26](#)).

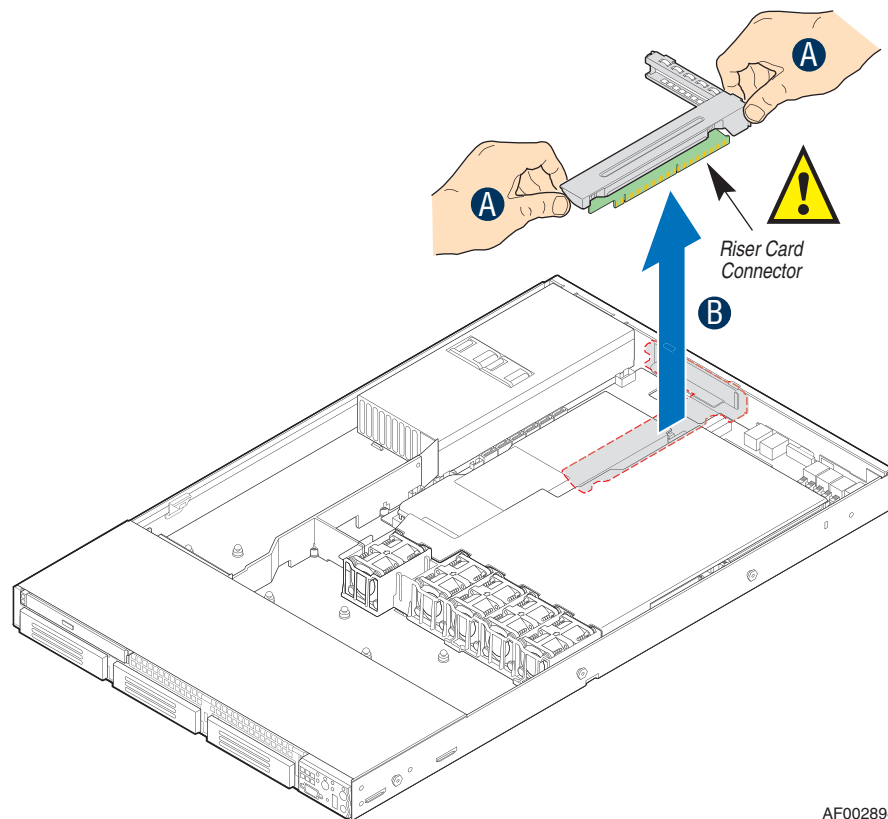

AF002894

Figure 26. Removing PCI Riser Assembly from the Server System

Caution: Place the riser assembly upside down to avoid damage to the riser card connector.

4. Do one of the following:
 - If you need to add or replace a PCI add-in card, see [“Installing and Removing a PCI Add-in Card”](#) on page 44.
 - If you need to add or replace a PCI riser connector, see [“Replacing a PCI Riser Card”](#) on page 43.

- If you removed the PCI riser assembly for another procedure, continue with that procedure.

Installing the PCI Riser Assembly

To install the PCI riser assembly, follow these steps:

1. Lower the riser assembly into place (see letter “A” in [Figure 27](#)).
2. Align the two hooks in the riser assembly with the matching slots at the back of the server system (see letter “B” in [Figure 27](#)).

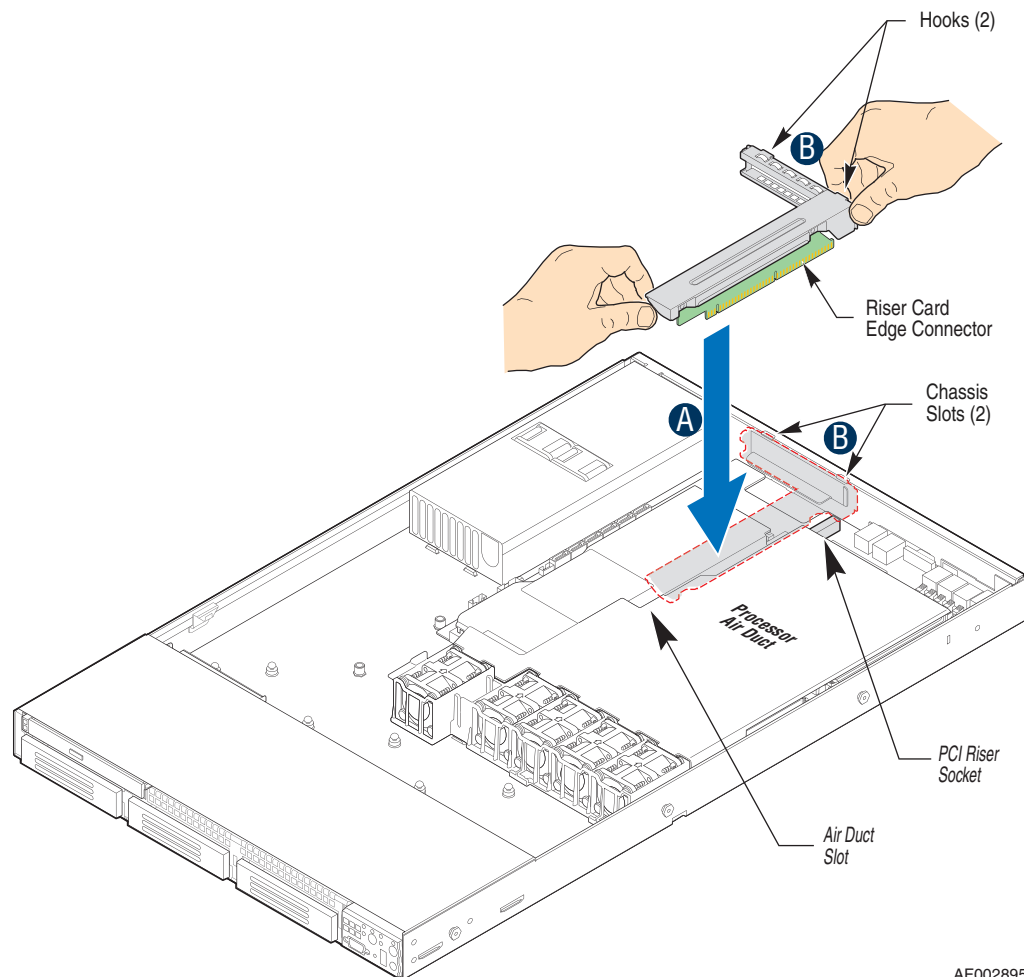

AF002895

Figure 27. Installing PCI Riser Assembly into the Server System

3. Press down uniformly until the two hooks on the rear of the PCI riser assembly engage the server system back panel slots. The riser card seats into the matching sockets on the server board.
4. Connect any cables to add-in cards that require them. See your add-in card documentation for information and add-in card requirements.

Replacing a PCI Riser Card

Caution: PCI riser connectors are NOT hot-swappable. Before removing or replacing the riser connector, you must first take the server out of service, turn off all peripheral devices connected to the system, turn off the system by pressing the power button, and unplug the AC power cord from the system or wall outlet.

Removing the PCI Express* Riser Card

To remove the PCI Express* riser card, follow these steps:

1. Disconnect any cables attached to any add-in cards.
2. Remove the PCI riser assembly. For instructions, see [“Removing the PCI Riser Assembly”](#) on page 41.
3. Remove any add-in cards from the PCI riser connector. For instructions, see [“Removing a PCI Add-in Card”](#) on page 45.
4. Remove the two screws securing the riser card to the riser assembly and remove the riser card (see [Figure 28](#)).

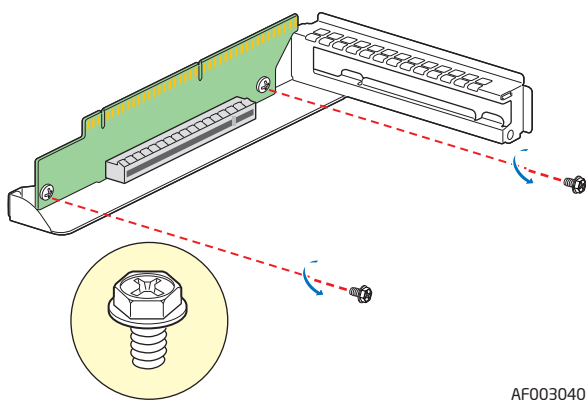

Figure 28. Removing the PCI Express* Riser Card

5. Install the replacement riser connector, if desired. For instructions, see [“Installing the Replacement PCI Express* Riser Card”](#) on page 44.
6. Install the PCI add-in card(s) if desired. For instructions, see [“Installing a PCI Add-in Card”](#) on page 44.
7. Install the PCI riser assembly into the server system. For instructions, see [“Installing the PCI Riser Assembly”](#) on page 42.
8. Connect any cables to add-in cards that require them. See your add-in card documentation for information and add-in card requirements.

Installing the Replacement PCI Express* Riser Card

To install the replacement PCI Express* riser card, follow these steps:

1. Disconnect any cables attached to any add-in cards.
2. Remove the PCI riser assembly. For instructions, see [“Removing the PCI Riser Assembly” on page 41](#).
3. Remove any add-in cards from the PCI riser connector. For instructions, see [“Removing a PCI Add-in Card” on page 45](#).
4. Position the riser card in the assembly such the holes on the card and the assembly align.
5. Secure the riser card using two screws (see [Figure 29](#)).

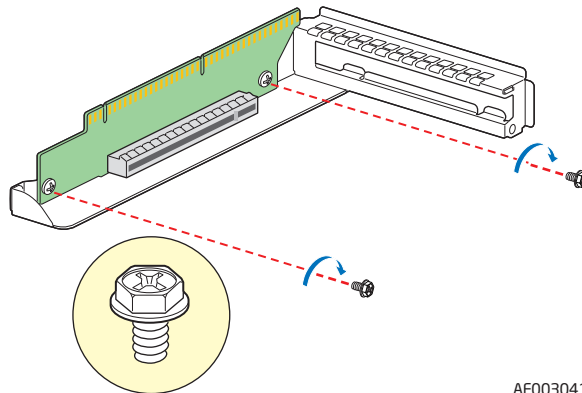

Figure 29. Installing the Replacement PCI Express* Riser Card

6. Install the PCI add-in card(s) if desired. For instructions, see [“Installing a PCI Add-in Card” on page 44](#).
7. Install the PCI riser assembly into the server system. For instructions, see [“Installing the PCI Riser Assembly” on page 42](#).
8. Connect any cables to add-in cards that require them. See your add-in card documentation for information and add-in card requirements.

Installing and Removing a PCI Add-in Card

The instructions below describe how to install and remove a PCI add-in card.

Installing a PCI Add-in Card

To install a PCI add-in card, follow these steps:

1. Remove the PCI riser assembly. For instructions, see [“Removing the PCI Riser Assembly” on page 41](#).

2. Remove the filler panel from the add-in card slot (see letter “A” in [Figure 30](#)).
3. Remove the screw (see letter “B” in [Figure 30](#)).
4. Insert add-in card until it seats in riser card connector (see letter “C” in [Figure 30](#)).
5. Secure the add-in card with screw (see letter “D” in [Figure 30](#)).

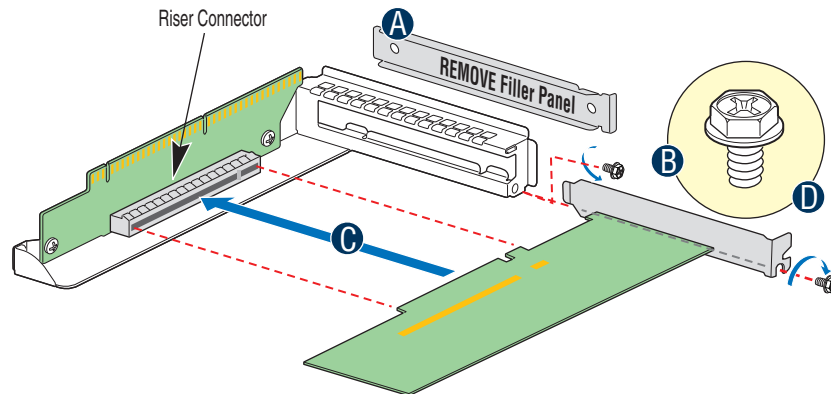

AF002853

Figure 30. Installing a Full-height Add-In Card

6. Install the PCI riser assembly into the server system. For instructions, see “[Installing the PCI Riser Assembly](#)” on page 42.

Removing a PCI Add-in Card

To remove a PCI add-in card, follow these steps:

1. Remove the PCI riser assembly. For instructions, see “[Removing the PCI Riser Assembly](#)” on page 41.
2. Remove the screw securing the add-in card to the add-in card slot (see letter “A” in [Figure 31](#)).
3. Remove the PCI add-in card from the riser card connector (see letter “B” in [Figure 31](#)).

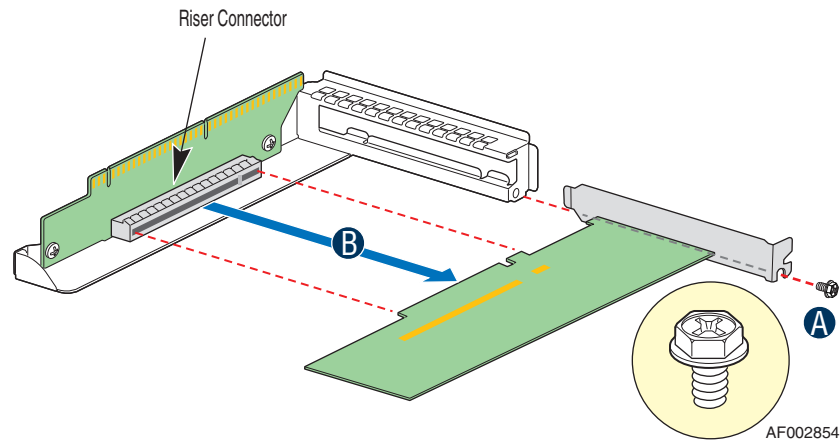

Figure 31. Removing a Full-height Add-In Card

Note: Make sure that the empty add-in card slot has the filler panel installed.

4. Install the PCI riser assembly into the server system. For instructions, see “Installing the PCI Riser Assembly” on page 42.

Removing and Installing the Processor Air Duct

Always operate your server system with the processor air duct in place. The air duct is required for proper airflow within the server system.

For instructions on adding or replacing a processor, first remove the processor air duct, and then see your server board user guide for instructions on processor installations and removals. Return to these instructions to reinstall the processor air duct after installing your processor and heatsink.

Removing the Processor Air Duct

To remove the processor air duct, follow these steps:

1. Remove the PCI riser assembly. For instructions, see “Removing the PCI Riser Assembly” on page 41.
2. Lift the processor air duct from its location over the two processor sockets.

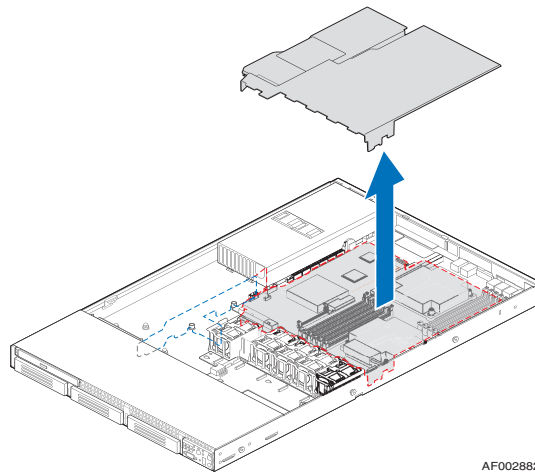

Figure 32. Removing the Processor Air Duct

Installing the Processor Air Duct

Place the processor air duct over the processor socket(s) (see [Figure 33](#)). The front edge of the air duct should align correctly with the notches on the fan module. Use caution not to pinch or disengage cables that may be near or under the air duct.

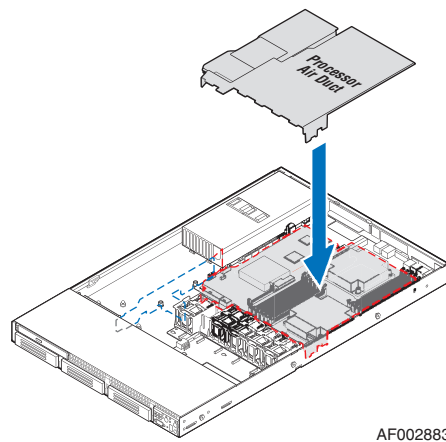

Figure 33. Installing the Processor Air Duct

Installing and Removing Memory

The silkscreen on the board displays DIMM A1, DIMM A2, DIMM B1, DIMM B2, DIMM C1, DIMM C2 for DIMMs on CPU socket 1 and DIMM D1, DIMM D2, DIMM E1, DIMM E2, DIMM F1, DIMM F2 for DIMMs on CPU socket 2.

Installing DIMMs

To install DIMMs, follow these steps:

1. Remove the PCI riser assembly. For instructions, see [“Removing the PCI Riser Assembly”](#) on page 41.
2. Remove the processor air duct. For instructions, see [“Removing the Processor Air Duct”](#) on page 46.
3. Locate the DIMM sockets (see [Figure 34](#)).

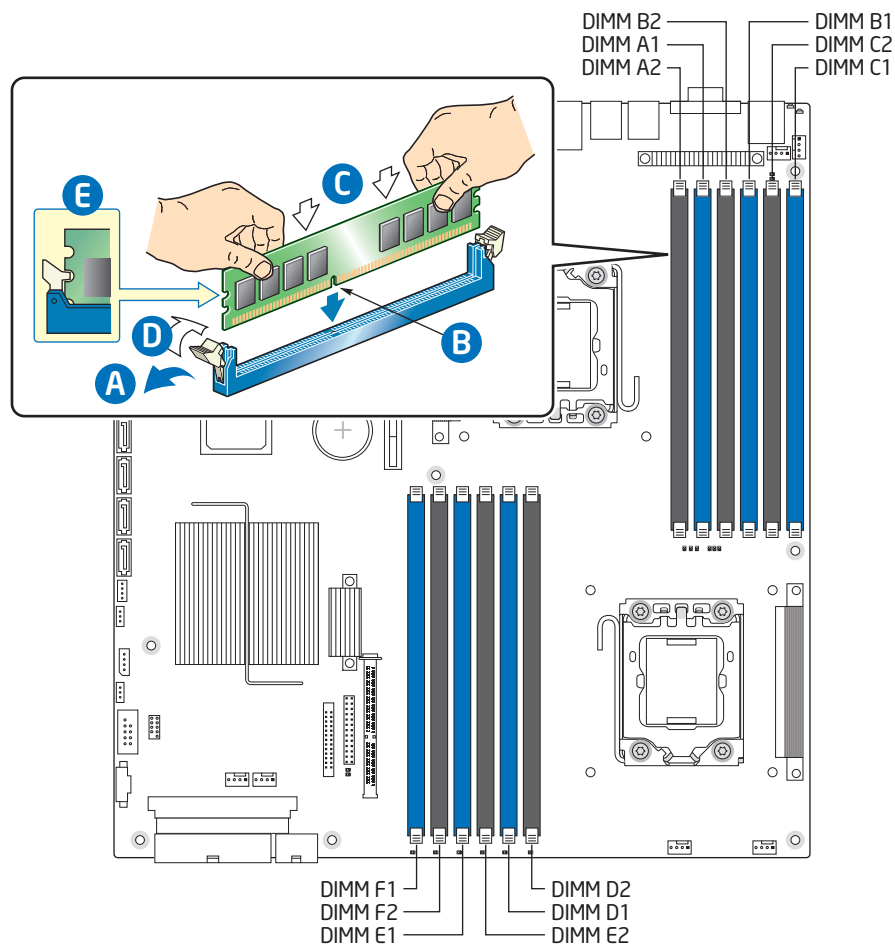

AF002884

Figure 34. Installing the Memory

4. Make sure the clips at either end of the DIMM socket(s) are pushed outward to the open position (see letter “A” in [Figure 34](#)).
5. Holding the DIMM by the edges, remove it from its anti-static package.

6. Position the DIMM above the socket. Align the notch on the bottom edge of the DIMM with the key in the DIMM socket (see letter “B” in [Figure 34](#) - the arrow is pointing to the key in the socket).
7. Insert the bottom edge of the DIMM into the socket.
8. When the DIMM is correctly positioned, push down on the top edge of the DIMM until the retaining clips snap into place (see letter “C” in [Figure 34](#)).
9. Make sure the clips are firmly in place (see letter “D” in [Figure 34](#)).

Removing DIMMs

To remove a DIMM, follow these steps:

1. Remove the PCI riser assembly. For instructions, see [“Removing the PCI Riser Assembly” on page 41](#).
2. Remove the processor air duct. For instructions, see [“Removing the Processor Air Duct” on page 46](#).
3. Locate the DIMM sockets (see [Figure 34](#)).
4. Gently spread the retaining clips at each end of the socket. The DIMM lifts from the socket.
5. Holding the DIMM by the edges, lift it from the socket, and store it in an anti-static package.

Installing and Removing the Processor

Caution: *Processor must be appropriate: You may damage the server board if you install a processor that is inappropriate for your server. See [“Additional Information and Software” on page 3](#) for a web link to the list of compatible processor(s).*

Caution: *ESD and handling processors: Reduce the risk of electrostatic discharge (ESD) damage to the processor by doing the following: (1) Touch the metal chassis before touching the processor or server board. Keep part of your body in contact with the metal chassis to dissipate the static charge while handling the processor. (2) Avoid moving around unnecessarily.*

Caution: *Protective socket cover needs to be removed for proper cooling of the processor; failure to remove the cover could result in damage to the system.*

Installing the Processor

To install a processor, follow these instructions:

1. Remove the PCI riser assembly. For instructions, see [“Removing the PCI Riser Assembly” on page 41](#).

2. Remove the processor air duct. For instructions, see “[Removing the Processor Air Duct](#)” on page 46.
3. Remove the heatsink, if installed. For instructions, see “[Removing the Heatsink](#)” on page 54.
4. Locate the processor socket.
5. Push the lever handle down and away from the socket to release it (see letter “A” in [Figure 35](#)).
6. Rotate the lever open all the way (see letter “B” in [Figure 35](#)).

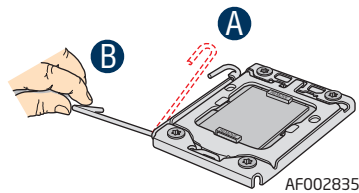

Figure 35. Lifting the Processor Socket Lever

7. Push the rear tab with your finger tip to bring the front end of the load plate open slightly (see letter “A” in [Figure 36](#)).
8. Open the load plate (see letter “B” in [Figure 36](#)).

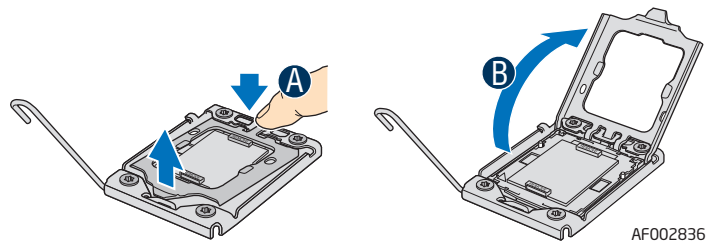

Figure 36. Opening the Load Plate

9. Remove the protective socket cover (see [Figure 37](#)).

Note: Do not touch the orientation posts on the socket; they are very sensitive and easily damaged.

Note: Retain the protective socket cover for use when removing a processor that will not be replaced.

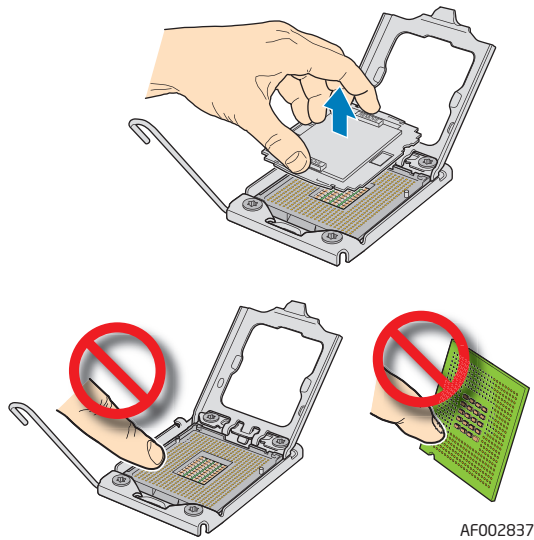

Figure 37. Removing the Protective Socket Cover

10. Remove the processor from the packaging box and remove the protective shipping cover (see [Figure 38](#)).



Figure 38. Removing the Processor Protective Cover

11. Orient the processor with the socket such that the orientation notches on the processor align with the two orientation posts on the socket, and insert the processor into the socket (see [Figure 39](#)).

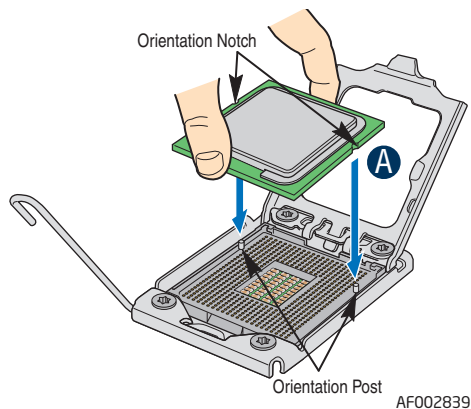

Figure 39. Installing the Processor

12. Close the CPU load plate all the way (see letter “A” in [Figure 40](#)).
13. Close the socket lever completely and ensure that the load plate tab engages under the socket lever when fully closed (see letter “B” in [Figure 40](#)).

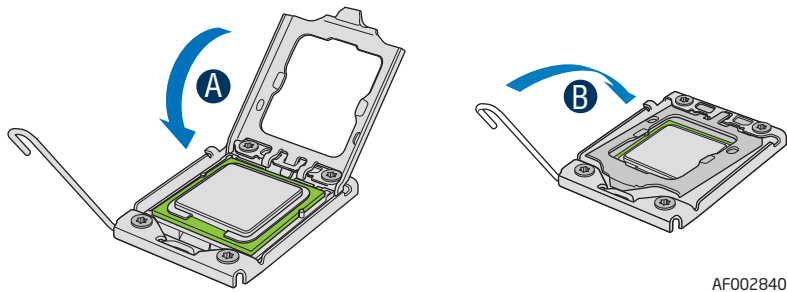

Figure 40. Closing the Load Plate

14. Install the heatsink. For instructions, see [“Installing the Heatsink”](#) on page 52.

Installing the Heatsink

You must install the processor before installing the heatsink. For instructions, see [“Installing the Processor”](#) on page 49.

Caution: *Improper installation can damage the heatsink. Pay close attention to the steps and perform each step exactly as indicated to avoid damage.*

Caution: *The heatsink has Thermal Interface Material (TIM) located on the bottom of it. Use caution when you unpack the heatsink so you do not damage the TIM.*

Note: *New unused heatsinks have adequate TIM on the bottom. If you are reusing a heatsink from replacing a processor, make sure there is adequate TIM present on the heatsink to support processor cooling.*

To install the heatsink, follow these steps:

1. Remove the protective film on the TIM, if present.
2. Orient the heatsink over the processor as shown in [Figure 41](#). The heatsink fins must be positioned as shown to provide correct airflow through the system.
3. Set the heatsink over the processor, lining up the four captive screws with the four posts surrounding the processor.
4. Loosely screw in the captive screws on the heatsink corners in a diagonal manner according to the numbers shown in [Figure 41](#) as follows:
 - a. Starting with the screw at location 1, engage the screw threads by giving it **two rotations** in the clockwise direction and stop. (**IMPORTANT: Do not fully tighten.**)
 - b. Proceed to the screw at location 2 and engage the screw threads by giving it two rotations and stop.
 - c. Engage screws at locations 3 and 4 by giving each screw two rotations and then stop.
 - d. Repeat steps 4a through 4c by giving each screw two rotations each time until all screws are lightly tightened upto a maximum of 8 inch-lbs torque.

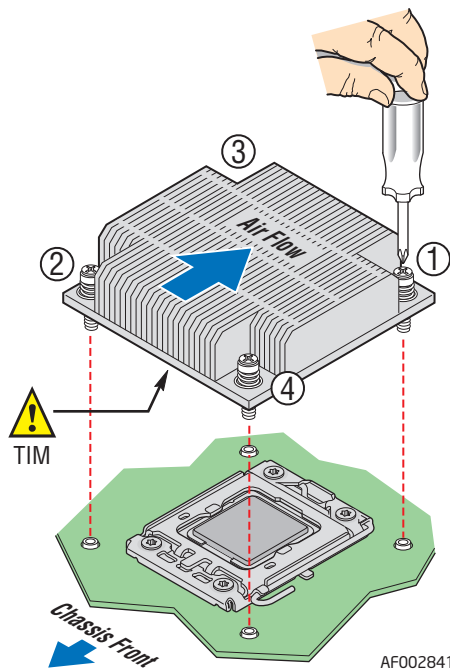

Figure 41. Installing the Heatsink (1U Passive Heatsink Shown)

Removing the Heatsink

To install or remove the processor, you must first remove the heatsink.

Caution: *Improper removal can damage the heatsink. Pay close attention to the steps and perform each step exactly as indicated to avoid damage.*

To remove the heatsink, follow these steps:

1. Remove the PCI riser assembly. For instructions, see [“Removing the PCI Riser Assembly” on page 41](#).
2. Remove the processor air duct. For instructions, see [“Removing the Processor Air Duct” on page 46](#).
3. Loosen the four captive screws on the heatsink corners in a diagonal manner according to the numbers shown in [Figure 42](#) as follows:
 - a. Starting with the screw at location 1, loosen it by giving it **two rotations** in the anticlockwise direction and stop. (**IMPORTANT:** *Do not fully loosen.*)
 - b. Proceed to the screw at location 2 and loosen it by giving it two rotations and stop.
 - c. Loosen screws at locations 3 and 4 by giving each screw two rotations and then stop.
 - d. Repeat steps 3a through 3c by giving each screw two rotations each time until all screws are loosened.
4. Do one of the following:
 - If removing the heatsink for the first time, do the following:
 - i. Lift the heatsink from the board.
 - ii. Remove and discard the spacer (see letter “C” in [Figure 42](#)).

Note: *The system is shipped with a spacer installed between the heatsink and the processor socket to protect the socket protective cover. This spacer will need to be removed and discarded before installing the processor.*

- If a processor is already installed, do the following:
 - i. Twist the heatsink slightly to break the seal between the heatsink and the processor.
 - ii. Lift the heatsink from the processor. If it does not pull up easily, twist the heatsink again. Do not force the heatsink from the processor. Doing so could damage the processor.

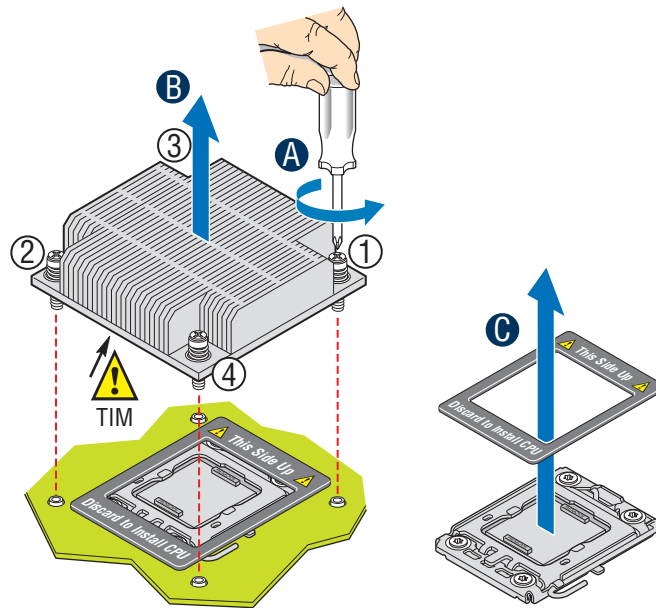

Figure 42. Removing the Heatsink

Removing the Processor

To remove the processor, follow these steps:

1. Remove the PCI riser assembly. For instructions, see [“Removing the PCI Riser Assembly”](#) on page 41.
2. Remove the processor air duct. For instructions, see [“Removing the Processor Air Duct”](#) on page 46.
3. Remove the heatsink. For instructions, see [“Removing the Heatsink”](#) on page 54.
4. Unplug the processor fan cable from the server board.
5. Open the processor socket lever (see [Figure 35](#)).
6. Open the CPU load plate (see [Figure 36](#)).
7. Remove the processor.
8. If installing a replacement processor, see [“Installing the Processor”](#) on page 49 for instructions. Otherwise, install the protective socket cover over the empty processor socket.

Removing and Installing the Small Air Baffle

Some installation processes require that you remove the small air baffle that is placed behind the hard drive bays, near the front of your server. The following sections describe how to remove and then install the small air baffle. Use the steps in these sections only when it is indicated as necessary for a component installation process.

Always operate your server system with the small air baffle in place. The small air baffle is required for proper airflow within the server system.

Removing the Small Air Baffle

Pull up and out on the air baffle to remove it (see [Figure 43](#)).

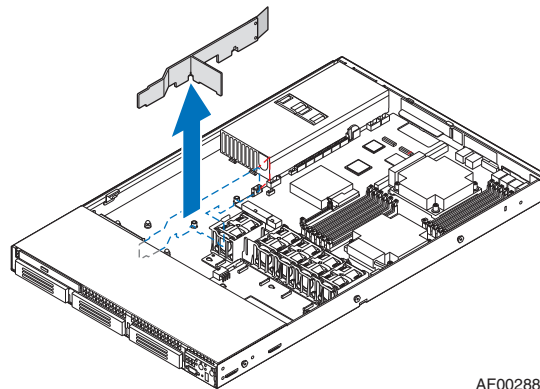

AF002885

Figure 43. Removing the Small Air Baffle

Installing the Small Air Baffle

To install the small air baffle, follow these steps:

1. Lower the baffle into the server system and position the baffle over the two standoff locations.
2. Snap the baffle into place as shown in [Figure 44](#).

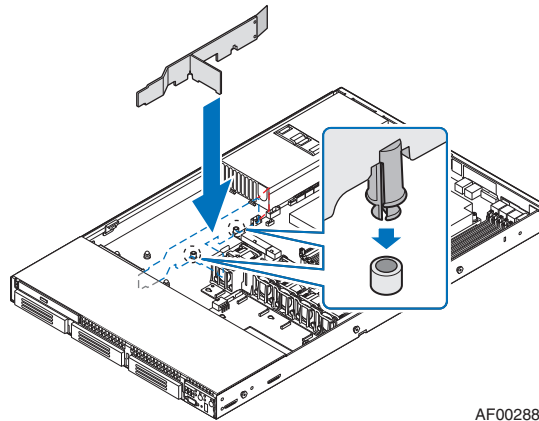

Figure 44. Installing the Small Air Baffle

For information about cabling around the air baffle, see “Cable Routing” on page 30.

Installing and Removing a Fixed Mount Hard Drive (Fixed Mount Hard Drive System Only)

Caution: Fixed mount hard drives are NOT hot-swappable. Before removing or replacing the drive, you must first take the server out of service, turn off all peripheral devices connected to the system, turn off the system by pressing the power button, and unplug the AC power cord from the system or wall outlet.

You can install up to three fixed SATA hard drives in the Intel® Server System SR1600UR (Product Code: SR1600UR).

Note: For a web link to a list of supported hardware, see “Additional Information and Software” on page 3.

Note: The fixed mount hard drives can be extracted only by accessing the drive carrier latch from inside the chassis.

Installing a Fixed Mount Hard Disk Drive

To install a fixed mount hard disk drive, follow these steps:

1. Release the fixed mount drive carrier from the drive bay by pressing the blue carrier latch (from inside the chassis) at the end of the black drive rail (see letter “A” in Figure 45) and pushing it forward.

- Slide the hard drive carrier out of the server system (see letter “B” in [Figure 45](#)).

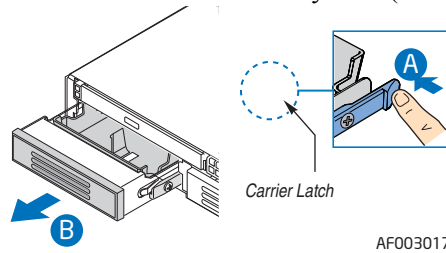

Figure 45. Removing Fixed Mount Drive Carrier from the Server System

- Remove the four screws securing the plastic retention device to the drive carrier (see [Figure 46](#)). Store the plastic retention device for future use. Also, save the screws; you need them to install the hard drive into the carrier.

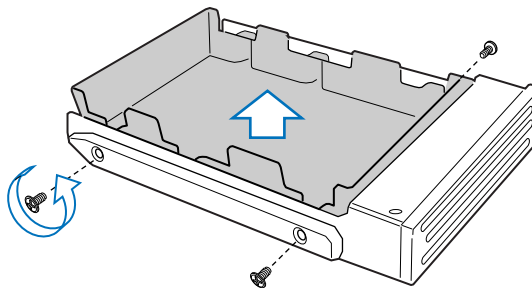
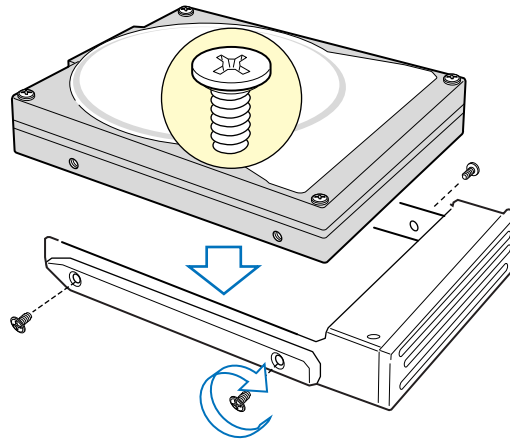

Figure 46. Removing the Drive Blank from the Fixed Hard Drive Carrier

- Remove the hard drive from its wrapper and place it on an antistatic surface.
- Set any jumpers and/or switches on the drive according to the drive manufacturer's instructions.
- With the drive circuit-side down, position the connector end of the drive so that it is facing the rear of the drive carrier.
- Align the holes in the hard disk drive to the holes in the drive carrier and attach it to the carrier with the screws that were attached to the plastic retention device (see [Figure 47](#)).



AF002381

Figure 47. Installing Fixed Hard Drive into the Carrier

8. Slide the hard drive carrier into the server system until it clicks into place.

Note: All hard drive carriers must be installed in the server system and populated with either a drive or a drive blank to maintain system thermals.

9. Connect one end of the SATA data cable(s) to the SATA connector(s) on the server board (see letter “A” in Figure 48).
10. Connect the opposite end of the SATA data cable(s) to the hard drive(s) (see letter “B” in Figure 48).
11. Connect the SATA power connector(s) to each installed hard drive (see letter “C” in Figure 48).

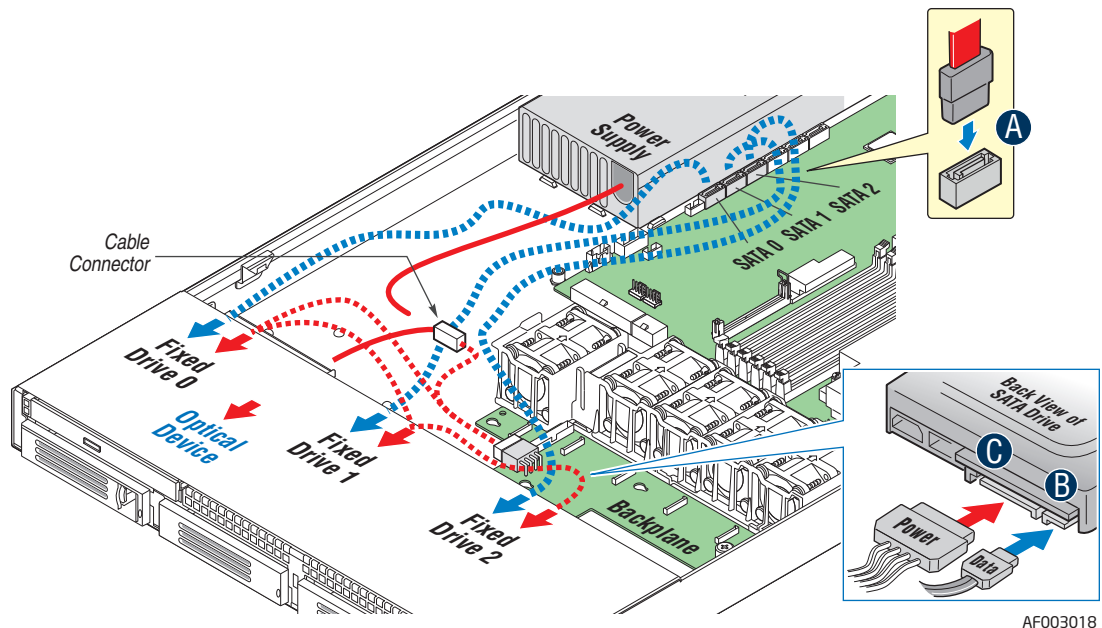

AF003018

Figure 48. Installing the Hard Drive Cables

Removing a Fixed Mount Hard Disk Drive

To remove a fixed mount hard disk drive, follow these steps:

1. Disconnect all cables to the hard drive(s).
1. Release the fixed mount drive carrier from the drive bay by pressing the blue carrier latch (from inside the chassis) at the end of the black drive rail (see letter “A” in [Figure 45](#)) and pushing it forward.
2. Slide the hard drive carrier out of the server system (see letter “B” in [Figure 45](#))
3. Remove the four screws that attach the hard drive to the carrier. Remove the drive from the carrier and store the drive in an anti-static bag.

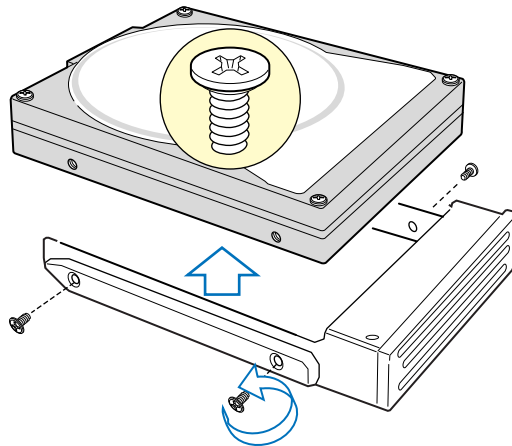

AF002382

Figure 49. Removing Fixed Hard Drive from the Server System

4. Do one of the following:
 - If you want to replace the hard drive, install the replacement drive using the four screws you just removed. For instructions, see [“Installing a Fixed Mount Hard Disk Drive”](#) on page 57.
 - If the hard drive will not be replaced, install a drive blank into the carrier using the four screws you just removed.

Note: To maintain proper system cooling, all hard drive carriers must be installed in the server system and populated with either a drive or a drive blank.

5. Slide the hard drive carrier into the server system until it clicks into place.

Installing and Removing a Hot-swap Hard Drive (Hot-swap Hard Drive System Only)

You may install up to three hot-swap SAS or SATA drives in the Intel® Server System SR1600UR (Product Code: SR1600URHS).

Cautions: *If you install less than three drives or devices, the empty drive bays must be occupied by carriers with baffles to maintain proper system cooling.*

To avoid possible damage to your server system, do not use older style drive carriers.

Note: *The server system does not support all hard drives. For a web link to a list of supported hard drives, see “Additional Information and Software” on page 3”.*

Installing a Hot-swap SAS or SATA Hard Disk Drive

To install a hot-swap SAS or SATA hard disk drive, follow these steps:

1. Press the green latch towards the black lever and pull out on the lever to release the hard drive carrier (see letter "A" in Figure 50).
2. Slide the carrier from the server system (see letter "B" in Figure 50).

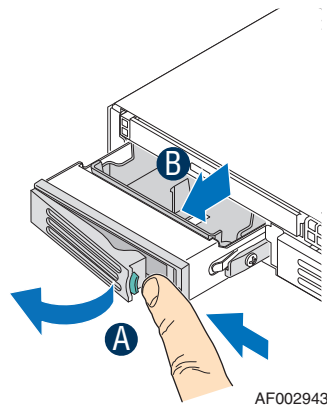
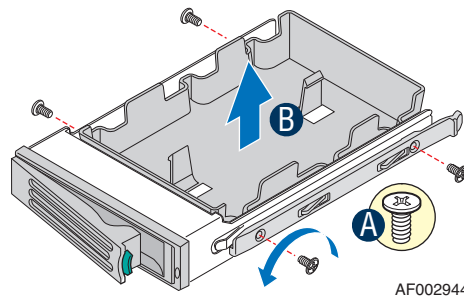

Figure 50. Removing Hot-swap Disk Carrier from the Server System

3. Remove the four screws that attach the plastic retention device or the previously installed hard drive to the drive carrier (see letter "A" in Figure 51). Remove the plastic retention device (see letter "B" in Figure 51) and store it for future use.



AF002944

Figure 51. Removing Retention Device from Drive Carrier

4. Remove the hard drive from its wrapper and place it on an antistatic surface.
5. Set any jumpers and/or switches on the drive according to the drive manufacturer's instructions.
6. With the drive circuit-side down, position the connector end of the drive so that it is facing the rear of the drive carrier.
7. Align the holes in the drive to the holes in the drive carrier and attach it to the carrier with the screws that were attached to the plastic retention device.

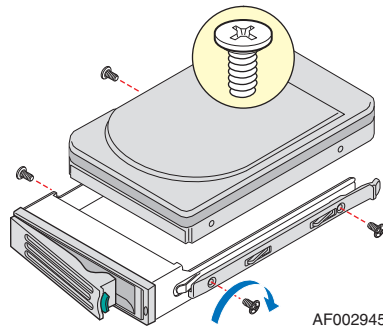

AF002945

Figure 52. Installing Hard Drive into Carrier

8. With the carrier lever in the open position, slide the drive assembly into the server system and push all the way until it stops (see letter "A" in Figure 53).
9. Close the lever to lock the drive assembly into place (see letter "B" in Figure 53).

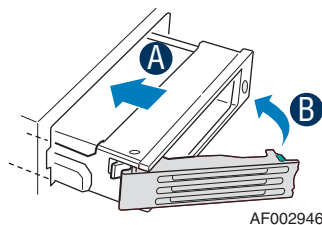

AF002946

Figure 53. Installing Drive Assembly into the Server System

Removing a Hot-swap SAS or SATA Hard Disk Drive

To remove a hot-swap SAS/SATA hard disk drive, follow these steps:

1. Press the green latch towards the black lever and pull out on the lever to release the hard drive carrier.
2. Slide the carrier from the server system.
3. Remove the four screws that attach the hard drive to the drive carrier. Lift the drive from the carrier and store the drive in an anti-static bag.
4. Do one of the following:
 - To install the replacement drive, see [“Installing a Hot-swap SAS or SATA Hard Disk Drive” on page 61](#).
 - If you are not installing a drive, place the plastic retention device into the drive carrier and secure the device by inserting the four screws your removed from the hard drive into the screw locations on the carrier.

Note: *To maintain proper system cooling, all hard drive carriers must be installed in the server system and populated with either a drive or a drive blank.*

5. With the black lever in the fully open position, slide the drive carrier into the server system and push all the way until it stops.
6. Close the lever to lock the drive carrier into place.

Installing and Removing a Slimline Optical Drive or Internal USB Floppy

You can install a SATA optical drive in the slimline optical drive bay.

In the Intel[®] Server System SR1600UR with hot-swap hard drives (Product Code: SR1600URHS), you can also install a slimline USB floppy drive. The USB floppy drive can be inserted into either the slimline bay or hard drive bay directly below the slimline bay.

Cautions: *Slimline optical drives and USB floppy drives are NOT hot-swappable. Before removing or replacing the drive, you must first take the server out of service, turn off all peripheral devices connected to the system, turn off the system by pressing the power button, and unplug the AC power cord from the system or wall outlet.*

To maintain proper system cooling, a filler blank must be installed if you do not install a device at this location.

Note: *A USB Floppy drive is not supported in the Intel[®] Server System SR1600UR with fixed mount hard drives (Product Code: SR1600UR).*

For a web link to a list of supported hardware, see [“Additional Information and Software” on page 3](#).

Installing a Slimline Optical Drive or Internal USB Floppy

To install a slimline optical drive or USB floppy, follow these steps:

1. Remove the slimline drive bay filler panel, if installed.
2. Obtain the optical drive and the drive tray.
3. Align the two holes on the left edge of the optical drive with the two metal tabs in the tray (see letter “A” in [Figure 54](#)).
4. Lower the opposite side of the optical drive into the tray until it clicks into place (see letter “B” in [Figure 54](#)).

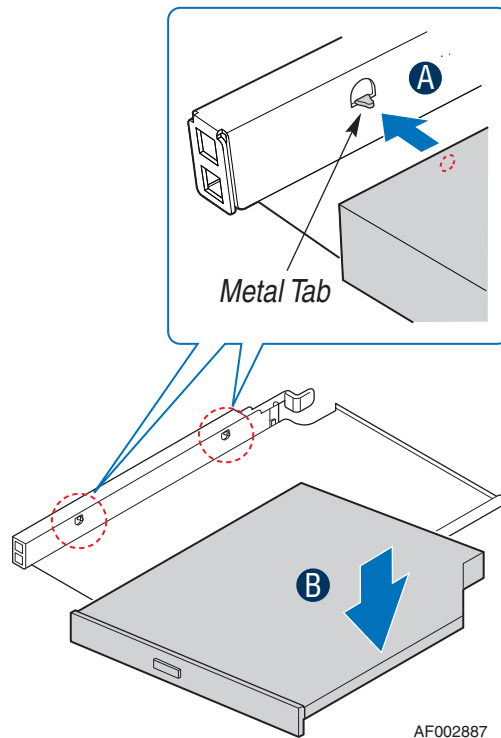
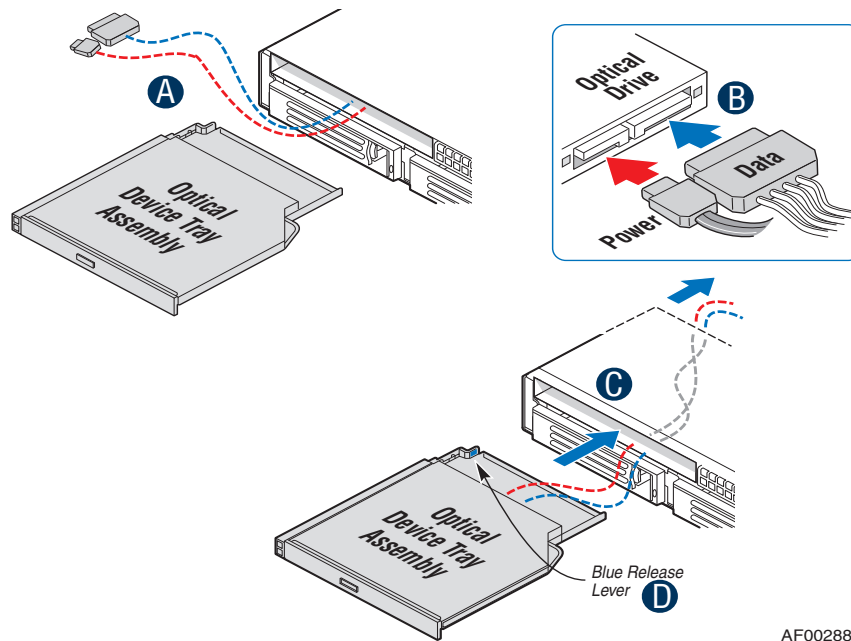

Figure 54. Installing an Optical Drive into the Drive Tray

5. Pull the power and data cables through the front of the chassis opening (see letter “A” in [Figure 55](#)).
6. Connect the cables to the rear of the optical device (see letter “B” in [Figure 55](#)).
7. From the back side of the device bay, pull the cables back into the chassis opening as you insert the device. Push the device all the way from the front until it clicks (see letter “C” in [Figure 55](#)).
8. Verify that the blue release lever on the tray (see letter “D” in [Figure 55](#)) locks into place.



AF002888

Figure 55. Installing an Optical Drive Assembly into the Server System

9. Connect the SATA end of the cable to one of the SATA connectors on the server board (see letter “B” in Figure 56).

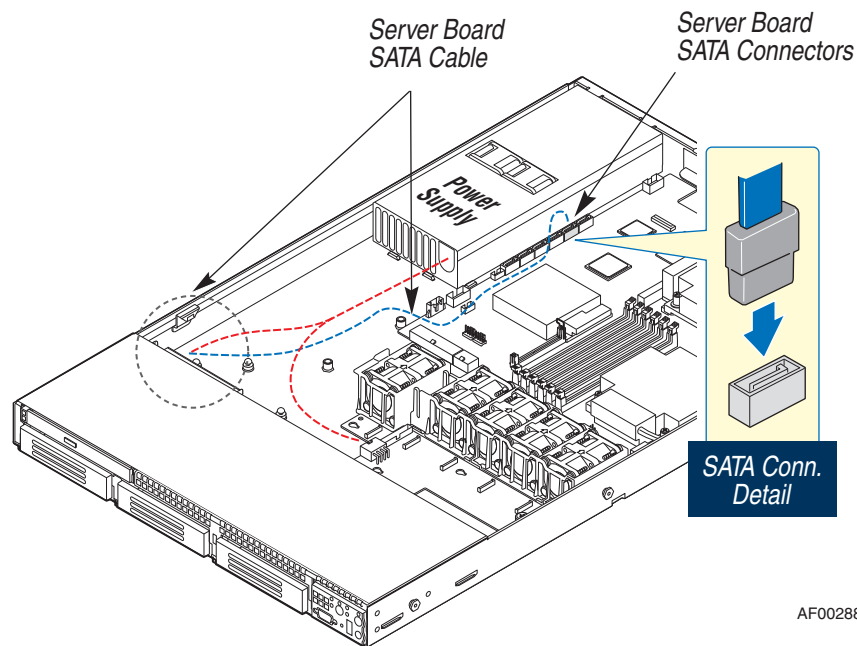

AF002889

Figure 56. Connecting the Optical Device Data Cable

10. (Optional) For installing the optional USB floppy drive, note the location of the USB connector on the backplane and refer to the documentation that came with the device.

Removing a Slimline Optical Drive or Internal USB Floppy

To remove the slimline optical drive or USB floppy, follow these steps:

1. If removing an internal USB floppy drive, unplug it from the backplane.
2. Disconnect the power and data cables from the rear of the optical device.
3. Press the blue release lever (from inside the chassis) to unlock the optical drive tray and remove the slimline optical drive tray assembly from the server system (see [Figure 57](#)).

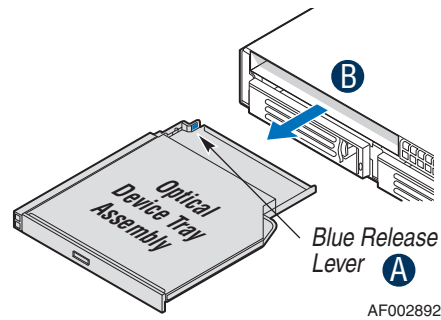
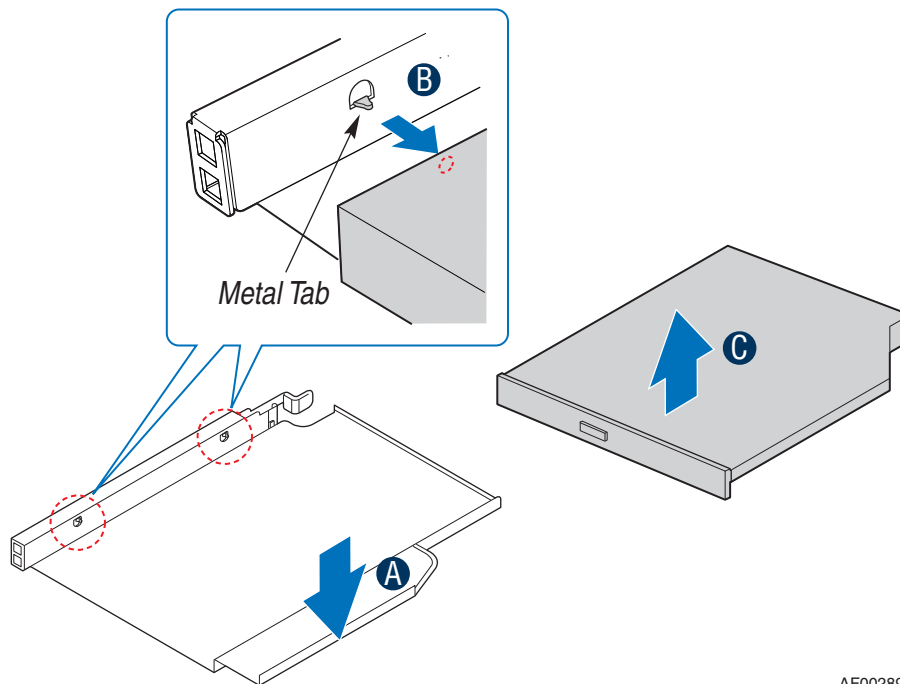

Figure 57. Removing the Slimline Optical Drive Assembly from the Server System

4. Press downward on the side of the tray (see letter “A” in [Figure 58](#)) and disengage the drive from the two metal tabs on the opposite side of the tray (see letter “B” in [Figure 58](#)).
5. Slide the optical drive out (see letter “C” in [Figure 58](#)) to remove it from the tray.



AF002893

Figure 58. Removing the Slimline Optical Drive from the Tray

Filling Empty Server System Bays

You must install either a filler panel, drive blank, or empty drive carrier into an empty drive bay. To access the drive bays, remove the front bezel if it is installed. For instructions, see [“Removing the Front Bezel”](#) on page 38.

With the bezel removed, install the appropriate panel(s), blank, or empty hard drive bay(s) as follows:

- If you do not have an optical drive or floppy drive installed in the slimline bay, install the slimline filler panel.
- If you do not have a hard drive installed, install the drive blank into the hard drive carrier.
- Install empty hard drive carriers into any remaining empty hard drive bays.

Installing and Removing the I/O Expansion Module

Installing the I/O Expansion Module

To install the I/O expansion module, follow these steps:

1. Remove the PCI riser assembly. For instructions, see [“Removing the PCI Riser Assembly” on page 41](#).
2. Remove the processor air duct. For instructions, see [“Removing the Processor Air Duct” on page 46](#).
3. Squeeze the sides of the I/O expansion module filler panel(s) to disengage it from the server system back panel and remove it (see letter “A” in [Figure 59](#)).

Note: *If you are installing an I/O expansion module that uses only one slot, remove the filler panel only from the slot shown so that the module can be attached to I/O connector 1. Do not remove the filler panel from the second slot.*

4. Attach the standoffs to the server board by pressing into the holes (see letter “B” in [Figure 59](#)).

Note: *For the 1-socket expansion module, install the three standoffs shown in gray. For the 2-socket expansion module, also install the fourth standoff shown in red..*

5. Position the I/O expansion module over the server board as shown in [Figure 59](#).
6. First fit the front of the module into the back panel slot(s), and then attach the module to the server board connector and engage the standoffs (see letter “C” in [Figure 59](#)).

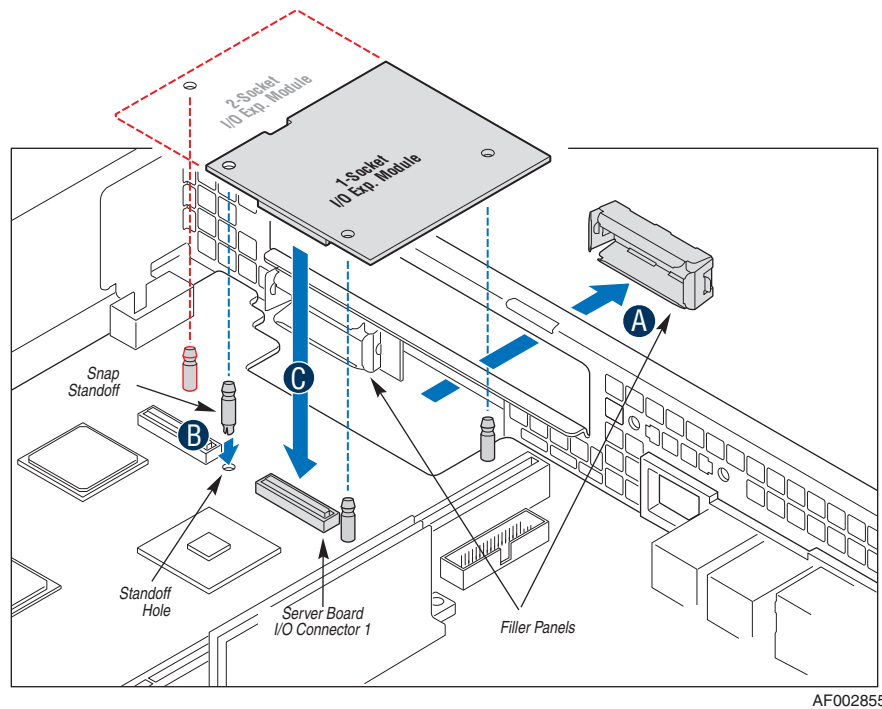

Figure 59. Installing the I/O Expansion Module to the Server System

7. Install the processor air duct. For instructions, see “Installing the Processor Air Duct” on page 47.
8. Install the PCI riser assembly into the server system. For instructions, see “Installing the PCI Riser Assembly” on page 42.

Removing the I/O Expansion Module

To remove the I/O expansion module, follow these steps:

1. Remove the PCI riser assembly. For instructions, see “Removing the PCI Riser Assembly” on page 41.
2. Remove the processor air duct. For instructions, see “Removing the Processor Air Duct” on page 46.
3. Disconnect the I/O expansion module from the server board connector and the standoffs and remove the module out of the server system (see letter “A” in Figure 60).
4. Remove the standoffs from the server board (see letter “B” in Figure 60).

5. Install the I/O expansion module filler panel(s) into the system back panel (see letter “C” in Figure 60).

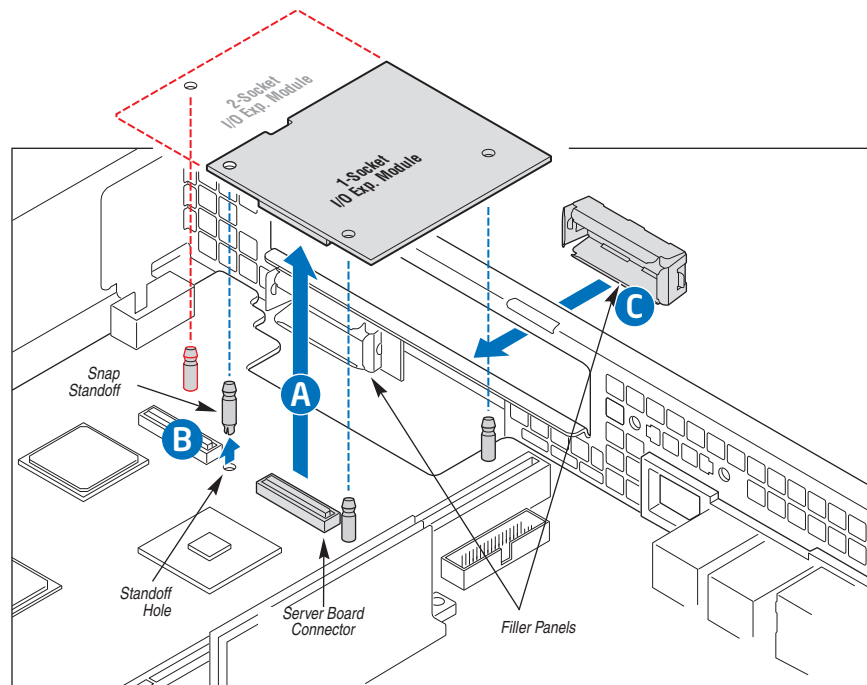

Figure 60. Removing the I/O Expansion Module from the Server System

6. Install the processor air duct. For instructions, see “Installing the Processor Air Duct” on page 47.
7. Install the PCI riser assembly into the server system. For instructions, see “Installing the PCI Riser Assembly” on page 42.

Installing and Removing the Intel® Remote Management Module 3

Installing the Intel® RMM3

To install Intel® Remote Management Module 3, follow these steps:

1. Remove the PCI riser assembly. For instructions, see “Removing the PCI Riser Assembly” on page 41.
2. Remove the processor air duct. For instructions, see “Removing the Processor Air Duct” on page 46.

3. Squeeze the sides of the Intel® RMM3 filler panel to disengage it from the server system back panel and remove it (see [Figure 61](#)).

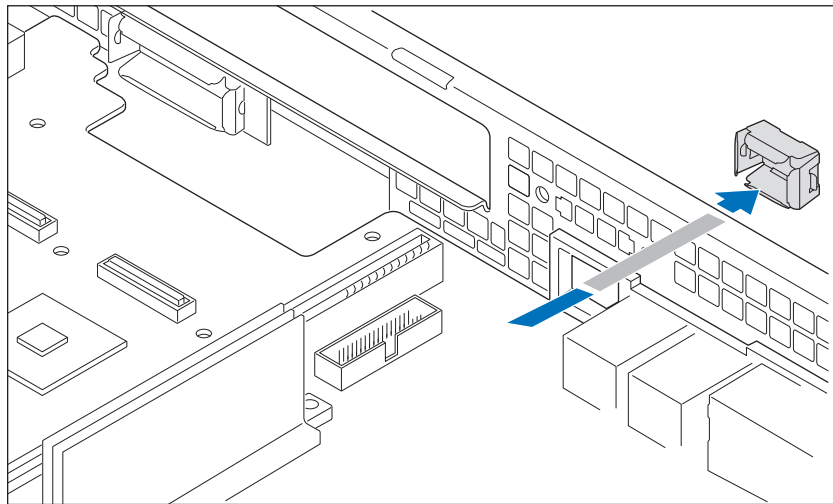

AF002997

Figure 61. Removing the Intel® RMM3 filler panel

4. Attach the Intel® RMM3 to the module bracket with two screws (see [Figure 62](#)).

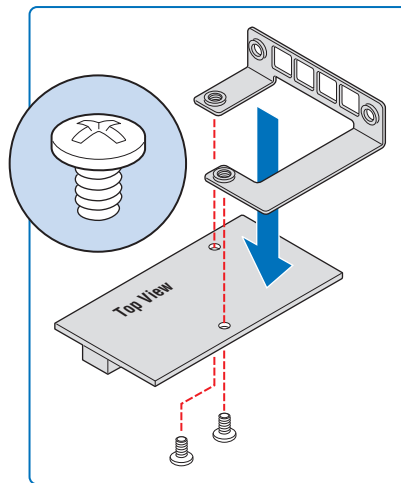

AF002948

Figure 62. Installing the Intel® RMM3 to the bracket

5. Connect one end of the cable (labeled 'RMM3') to the RMM3 connector on the Intel® RMM3 (see [Figure 63](#)).

Note: Cable connectors are keyed and can only go in one way.

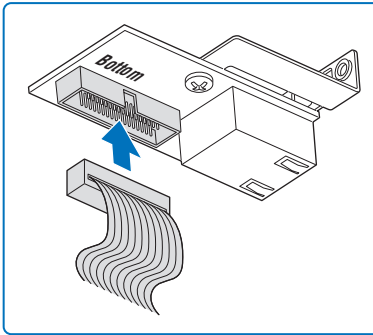

AF002949

Figure 63. Connecting the Intel® RMM3 cable

6. Connect the opposite end of the cable to the RMM3 connector on the server board (see letter “A” in [Figure 64](#)).
7. Attach the module bracket to the chassis with two screws (see letter “B” in [Figure 64](#)).

Note: The screws install from the back of the chassis.

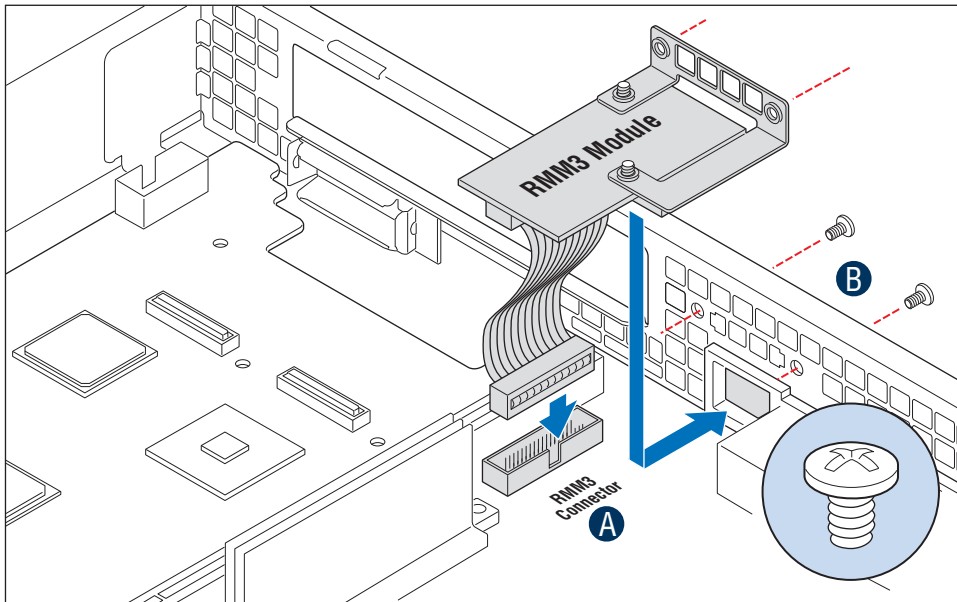

AF002857

Figure 64. Installing the Intel® RMM3 to the Server System

8. Install the processor air duct. For instructions, see [“Installing the Processor Air Duct”](#) on page 47.
9. Install the PCI riser assembly into the server system. For instructions, see [“Installing the PCI Riser Assembly”](#) on page 42.

Removing the Intel® RMM3

To remove Intel® Remote Management Module 3, follow these steps:

1. Remove the PCI riser assembly. For instructions, see “[Removing the PCI Riser Assembly](#)” on page 41.
2. Remove the processor air duct. For instructions, see “[Removing the Processor Air Duct](#)” on page 46.
3. Remove screws from the back of the chassis (see letter “A” in [Figure 65](#))
4. Disconnect the Intel® RMM3 from the connector on the server board (see letter “B” in [Figure 65](#)) and remove the module out of the server system (see letter “C” in [Figure 65](#)).

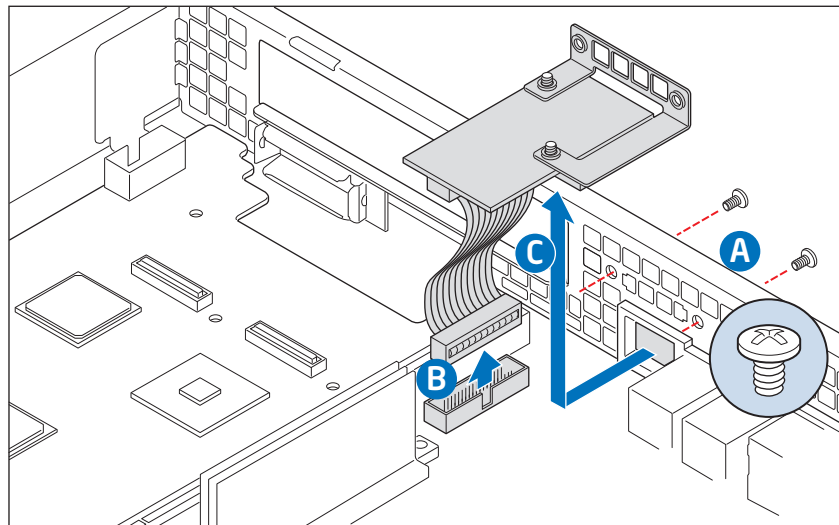

AF002858

Figure 65. Removing the Intel® RMM3 from the Server System

5. Install the Intel® RMM3 filler panel into the system back panel (see [Figure 66](#)).

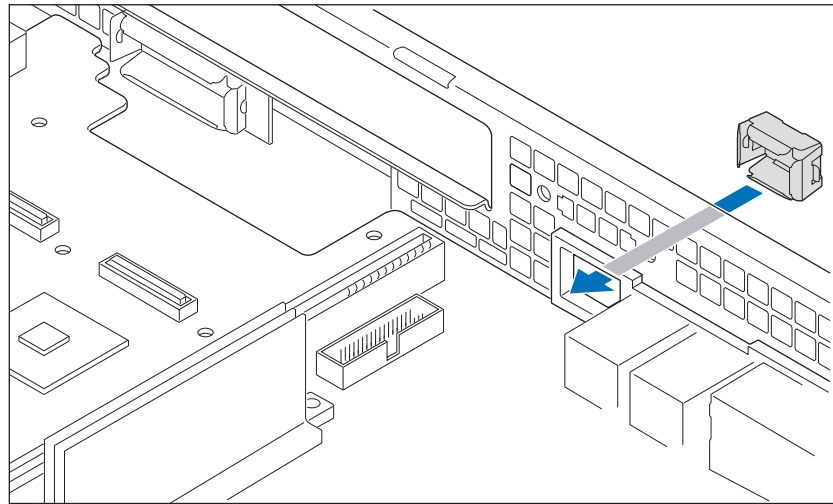

AF002998

Figure 66. Installing the Intel® RMM3 filler panel

6. Install the processor air duct. For instructions, see “[Installing the Processor Air Duct](#)” on page 47.
7. Install the PCI riser assembly into the server system. For instructions, see “[Installing the PCI Riser Assembly](#)” on page 42.

Removing and Installing the Fan Board (Fixed Mount Hard Drive System Only)

The Intel® Server System SR1600UR with fixed mount hard drives (Product Code: SR1600UR) includes a fan board. The following sections describe how to replace the fan board.

Removing the Fan Board

To remove the fan board, follow these steps:

1. Remove the PCI riser assembly. For instructions, see “[Removing the PCI Riser Assembly](#)” on page 41.
2. Remove the processor air duct. For instructions, see “[Removing the Processor Air Duct](#)” on page 46.
3. Disconnect all fan cables from the fan board.
4. Disconnect the power cable from the fan board (see letter “A” in [Figure 67](#)).
5. Remove the screw from the fan board (see letter “B” in [Figure 67](#)).

6. Hold the fan board only by the edges. Slide the fan board in the direction shown to release it and lift it over the retention pins (see letter “C” in [Figure 67](#)).
7. Lift the fan board out of the server system (see letter “D” in [Figure 67](#)).

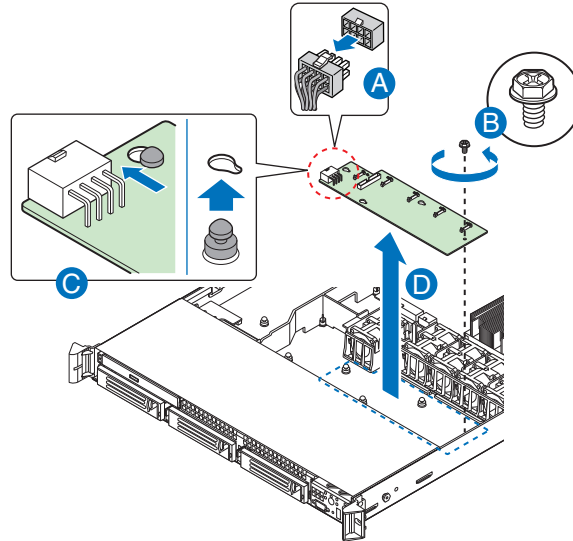

AF002905

Figure 67. Removing the Fan Board from the Server System

8. Install a replacement fan board. For instructions, see [“Installing the Fan Board”](#) on [page 76](#).

Installing the Fan Board

To install the fan board, follow these steps:

1. Lower the fan board into the system (see letter “A” in [Figure 68](#)) and position the fan board over the retention pins as shown.
2. Slide the fan board to the left (see letter “B” in [Figure 68](#)) to lock it in place and install the screw (see letter “C” in [Figure 68](#)).
3. Connect the power cable to the power connector on the fan board (see letter “D” in [Figure 68](#)).

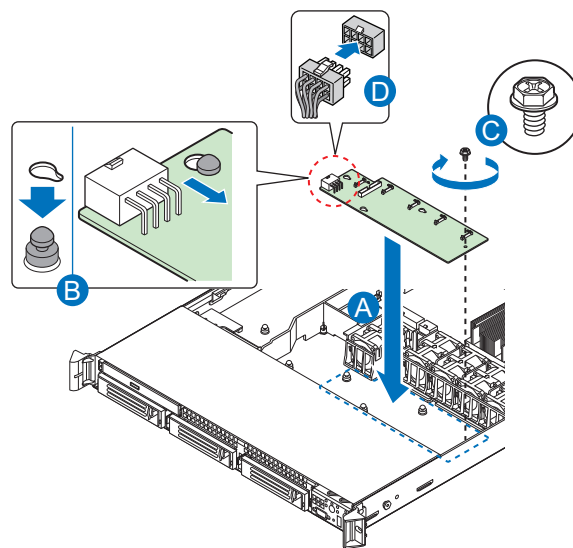

AF002906

Figure 68. Installing the Fan Board into the Server System

4. Connect the fan cables to the fan board.
5. Install the processor air duct. For instructions, see [“Installing the Processor Air Duct”](#) on page 47.
6. Install the PCI riser assembly into the server system. For instructions, see [“Installing the PCI Riser Assembly”](#) on page 42.

Installing and Removing the Backplane Board (Hot-swap Hard Drive System Only)

The Intel® Server System SR1600UR with hot-swap drives (Product Code: SR1600URHS) requires that you install a hot-swap backplane to make the system operational. Two backplane options are supported:

- Active SAS RAID Backplane, capable of supporting SAS hard drives
- Passive SATA Backplane, capable of supporting SATA hard drives.

The steps for installing and replacing both the backplanes are nearly identical. Use the following section for both backplane options. Where necessary, differences between the two backplanes are noted.

Installing the Backplane Board

To install the backplane board, follow these steps:

1. Remove the PCI riser assembly. For instructions, see [“Removing the PCI Riser Assembly” on page 41](#).
2. Remove the processor air duct. For instructions, see [“Removing the Processor Air Duct” on page 46](#).
3. Lower the backplane board into the system and position the backplane board over the six chassis standoffs (see letter “A” in [Figure 69](#)).

Note: *Make sure that all the cables are seated over the backplane.*

4. Press down uniformly until each standoff is inserted into the corresponding hole on the backplane (see letter “B” in [Figure 69](#)).
5. Slide the backplane board in the direction shown (see letter “C” in [Figure 69](#)) to lock it in place.
6. Secure the backplane with the thumbscrew (see letter “D” in [Figure 69](#)).

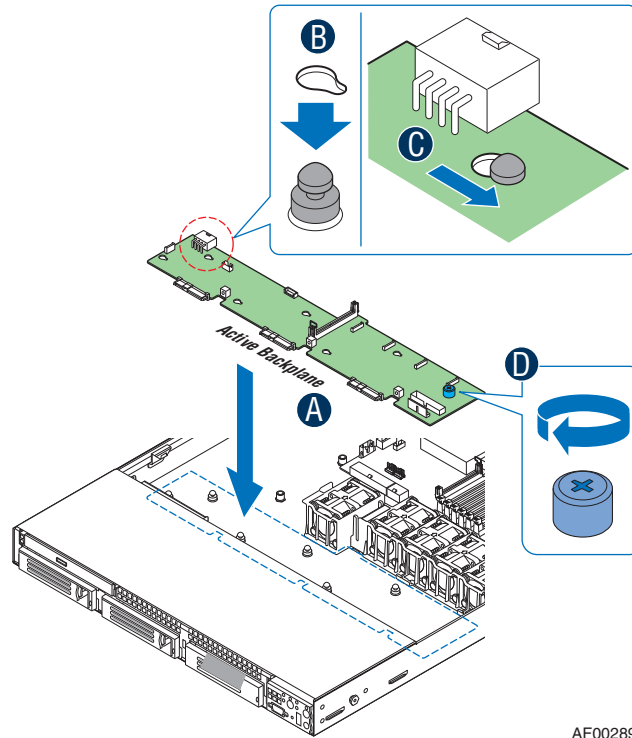

AF002896

Figure 69. Installing the Backplane into the Server System

7. Install the bridge board as follows:
 - a. Open the retention clips on both ends (see letter “A” in [Figure 70](#))
 - b. Insert the bridge board into the bridge board connector on the backplane and server board (see letter “B” in [Figure 70](#)). Make sure that the connector edges on both sides align correctly with the slots.

- c. Close the retention clips on both ends (see letter “C” in [Figure 70](#)).

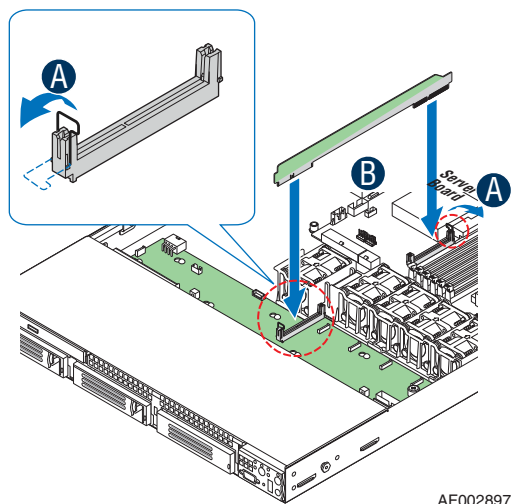

Figure 70. Installing the Bridge Board

8. Connect the fan cables to the corresponding connectors on the backplane (see letter “A” in [Figure 71](#)).
9. Connect the USB and data cables from the control panel to the USB connector and front panel connector on the backplane (see letter “B” in [Figure 71](#)).
10. Connect the power cable to the power connector on the backplane (see letter “C” in [Figure 71](#)).
- 11. Passive backplane only:** Do the following:

- a. Connect the hard drive SATA cables from either the server board or the add-in card to the corresponding SATA connectors on the backplane (see letter “D” in [Figure 71](#) - connection from the server board shown).

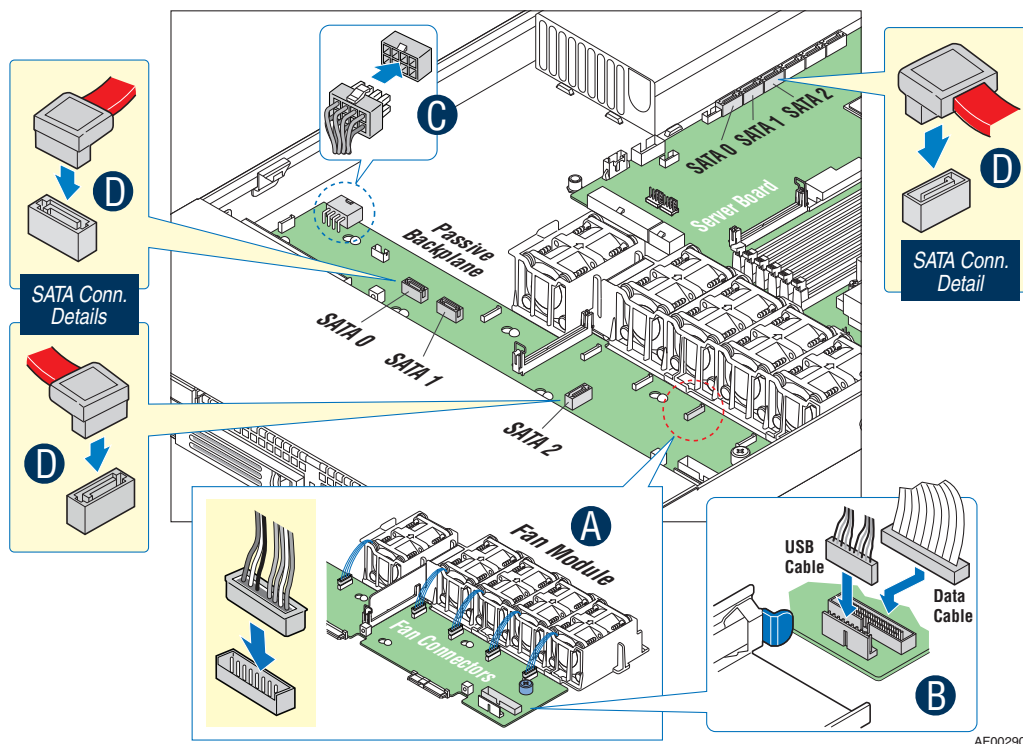

Figure 71. Making Cable Connections

- b. If you connect the SATA cables from the passive backplane to the add-in card, also install the 3-pin white cable between the HBA connector on the backplane and the add-in card to enable fault LED control.

Note: Do NOT connect the HBA cable in a system with an active backplane or when using the SATA connectors on the server board to connect the hard drive SATA cables.

12. Install the processor air duct. For instructions, see [“Installing the Processor Air Duct”](#) on page 47.
13. Install the PCI riser assembly into the server system. For instructions, see [“Installing the PCI Riser Assembly”](#) on page 42.

Removing the Backplane Board

To remove the backplane board, follow these steps:

1. Remove the PCI riser assembly. For instructions, see “[Removing the PCI Riser Assembly](#)” on page 41.
2. Remove the processor air duct. For instructions, see “[Removing the Processor Air Duct](#)” on page 46.
3. Disconnect all cables from the backplane board.
4. Remove the bridge board by opening the retention clips from the backplane and the server board (see letter “A” in [Figure 72](#)), and lifting straight up (see letter “B” in [Figure 72](#))

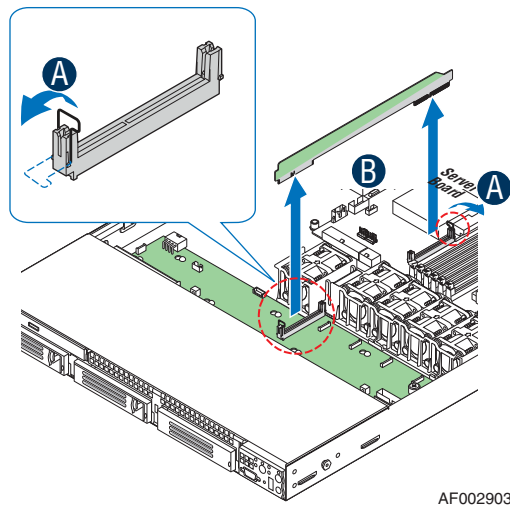
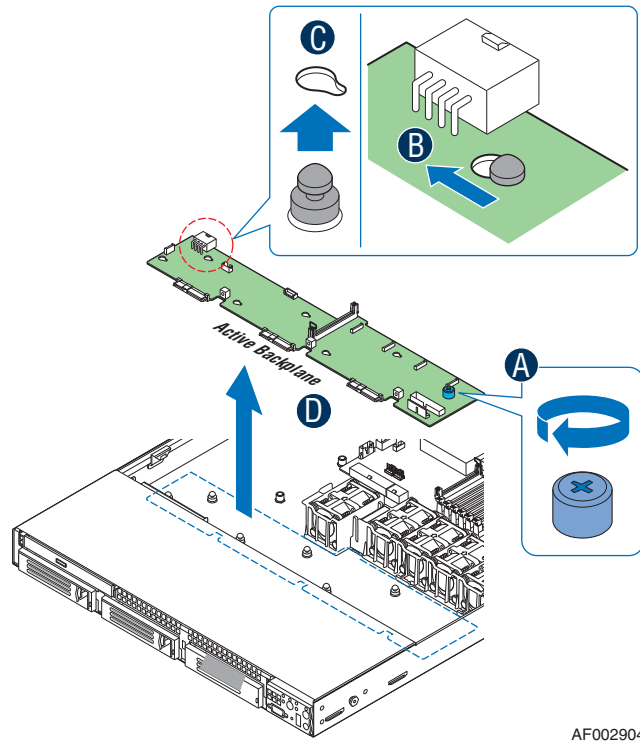

Figure 72. Removing the Bridge Board from the Server System

5. Loosen the thumbscrew on the backplane board (see letter “A” in [Figure 73](#)).
6. Hold the backplane board only by the edges and slide the backplane board in the direction shown to release it (see letter “B” in [Figure 73](#)).

7. Lift the backplane board from over the six standoffs (see letter “C” in [Figure 73](#)) and out of the server system (see letter “D” in [Figure 73](#)).



AF002904

Figure 73. Removing the Backplane from the Server System

8. Install a replacement backplane. For instructions, see “[Installing the Backplane Board](#)” on page 77.

Removing and Installing the Server Board

Removing the Server Board

To remove the server board, follow these steps:

1. If installed, remove the PCI riser assembly. For instructions, see [“Removing the PCI Riser Assembly” on page 41](#).
2. If installed, remove the processor air duct. For instructions, see [“Removing the Processor Air Duct” on page 46](#).
3. If installed, remove the blue air baffle. For instructions, see [“Removing the Small Air Baffle” on page 56](#).
4. **Hot-swap hard drive systems with passive backplane only:** Disconnect the hard drive SATA cables from the server board.
5. **Hot-swap hard drive systems only:** If installed, remove the bridge board. For instructions, see step 4 in [“Removing the Backplane Board” on page 81](#).
6. Remove the system fan assembly. For instructions, see [“Removing the System Fan Assembly” on page 90](#).
7. Disconnect all power cables coming from the power supply to the server board.
8. Remove the I/O expansion module, if installed. For instructions, see [“Removing the I/O Expansion Module” on page 69](#).
9. Remove the Intel[®] RMM3, if installed. For instructions, see [“Removing the Intel[®] RMM3” on page 73](#).
10. If installed, remove memory, processor heatsink(s), and processor(s) from the server board. For instructions, see [“Removing DIMMs” on page 49](#) and [“Removing the Heatsink” on page 54](#).
11. Remove the nine screws from the server board (see letter “A” in [Figure 74](#)) and lift the server board from the server system (see letter “B” in [Figure 74](#)).

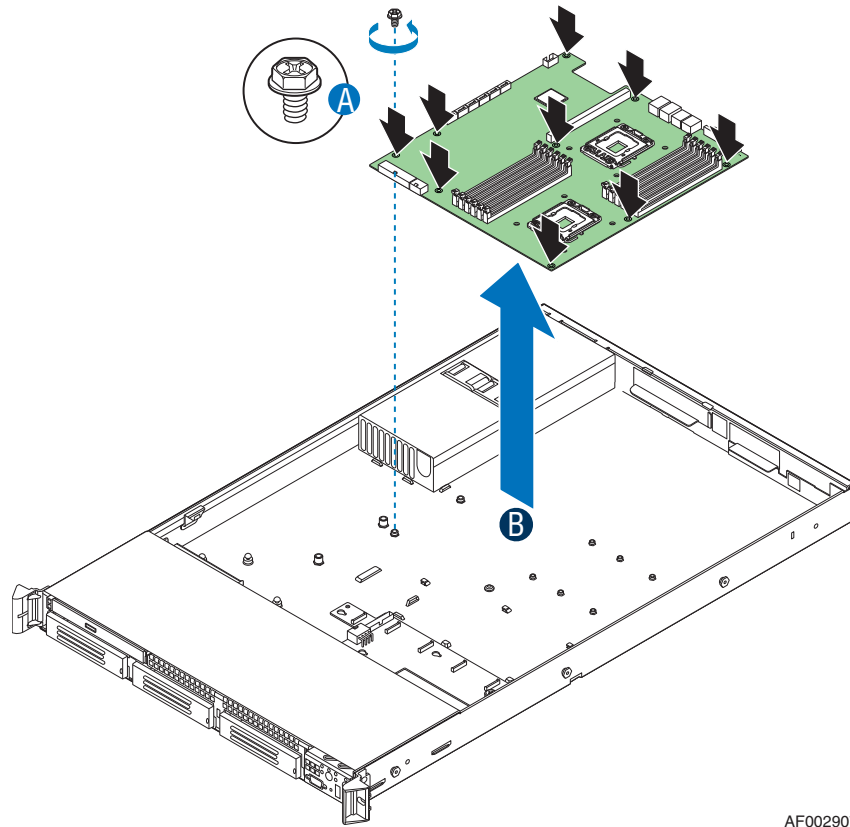

AF002907

Figure 74. Removing the Server Board

12. Install the replacement server board. For instructions, see “[Installing the Server Board](#)” on page 84.

Installing the Server Board

To install the server board, follow these steps:

1. Place the server board into the server system (see letter “A” in [Figure 75](#)).
2. Attach the server board with screws at the nine locations identified by black arrows (see letter “B” in [Figure 75](#)).

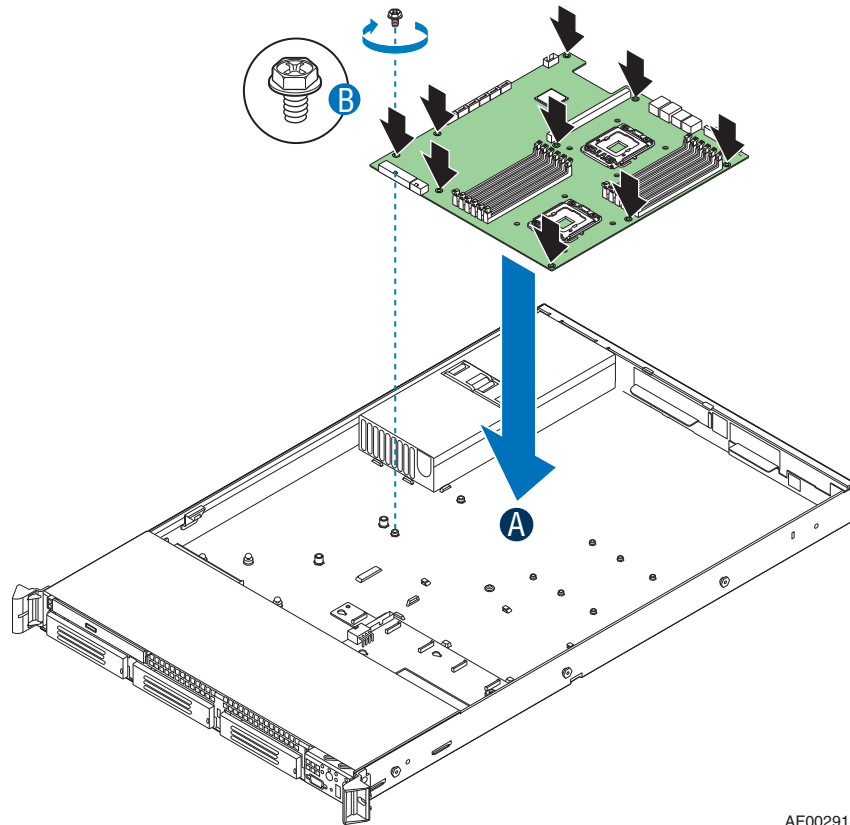

AF002914

Figure 75. Installing the Server Board

3. Connect all the power cables coming from the power supply to the server board.
4. Install memory. For instructions, see [“Installing DIMMs” on page 48](#).
5. Install processor(s). For instructions, see [“Installing the Processor” on page 49](#)
6. Install processor heatsink(s). For instructions, see [“Installing the Heatsink” on page 52](#).
7. Install the system fan assembly. For instructions, see [“Installing the System Fan Assembly” on page 91](#).
8. **Hot-swap hard drive systems only:** Install the bridge board. For instructions, see step 7 in [“Installing the Backplane Board” on page 77](#).
9. **Hot-swap hard drive systems with passive backplane only:** Connect the hard drive SATA cables from the backplane to the server board.
10. Install the blue air baffle. For instructions, see [“Installing the Small Air Baffle” on page 56](#).
11. If necessary, install the I/O expansion module. For instructions, see [“Installing the I/O Expansion Module” on page 68](#).

12. If necessary, install the Intel[®] RMM3. For instructions, see [“Installing the Intel[®] RMM3” on page 70](#).
13. Install the processor air duct. For instructions, see [“Installing the Processor Air Duct” on page 47](#).
14. Install the PCI riser assembly. For instructions, see [“Installing the PCI Riser Assembly” on page 42](#).

Replacing the Backup Battery

The lithium battery on the server board powers the RTC for up to 10 years in the absence of power. When the battery starts to weaken, it loses voltage, and the server settings stored in CMOS RAM in the RTC (for example, the date and time) may be wrong. Contact your customer service representative or dealer for a list of approved devices.

Warning: *Danger of explosion if battery is incorrectly replaced. Replace only with the same or equivalent type recommended by the equipment manufacturer. Discard used batteries according to manufacturer's instructions.*

Advarsel: Lithiumbatteri - Eksplosionsfare ved fejlagtig håndtering. Udskiftning må kun ske med batteri af samme fabrikat og type. Levér det brugte batteri tilbage til leverandøren.

Advarsel: Lithiumbatteri - Eksplosjonsfare. Ved utskifting benyttes kun batteri som anbefalt av apparatfabrikanten. Brukt batteri returneres apparatleverandøren.

Varning: Explosionsfara vid felaktigt batteribyte. Använd samma batterityp eller en ekvivalent typ som rekommenderas av apparattillverkaren. Kassera använt batteri enligt fabrikantens instruktion.

Varoitus: Paristo voi räjähtää, jos se on virheellisesti asennettu. Vaihda paristo ainoastaan laitevalmistajan suosittelemaan tyyppiin. Hävitä käytetty paristo valmistajan ohjeiden mukaisesti.

1. If installed, remove the PCI riser assembly. For instructions, see [“Removing the PCI Riser Assembly” on page 41](#).
2. If installed, remove the processor air duct. For instructions, see [“Removing the Processor Air Duct” on page 46](#).
3. Locate the battery.
4. Insert the tip of a small flat bladed screwdriver, or an equivalent, under the tab in the plastic retainer. Gently push down on the screwdriver to lift the battery.
5. Remove the battery from its socket.

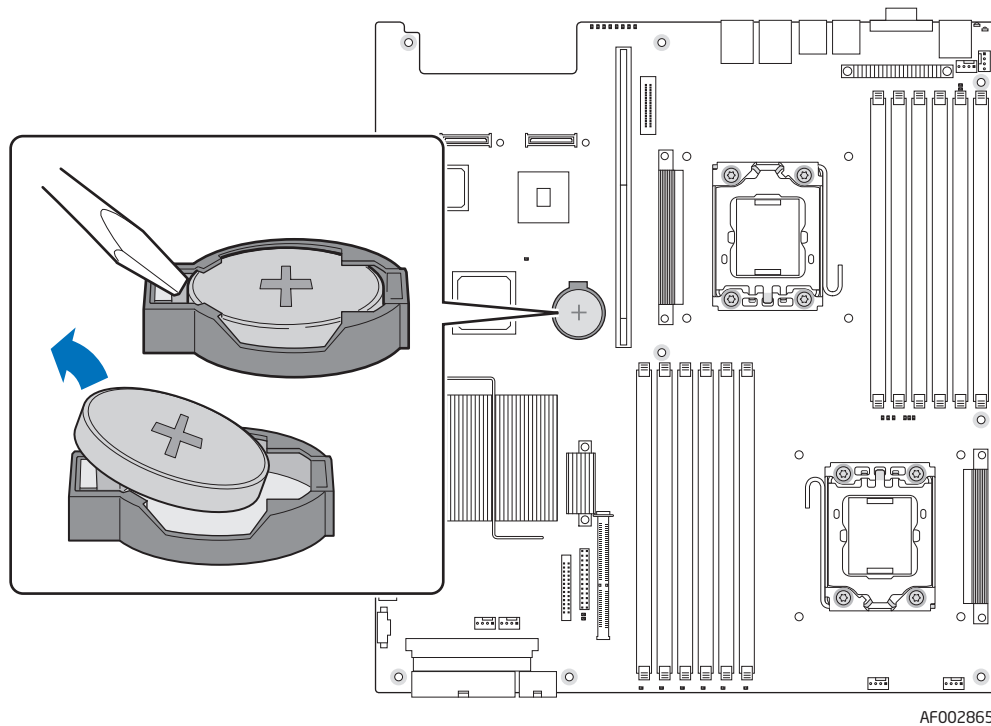

AF002865

Figure 76. Replacing the Backup Battery

6. Dispose of the battery according to local ordinance.
7. Remove the new lithium battery from its package, and, being careful to observe the correct polarity, insert it in the battery socket.

Note: You will need to run the BIOS setup to restore the system configuration settings to the RTC.

Replacing the Power Supply

Caution: The power supply is not hot-swappable. Before removing or replacing the power supply, you must first take the server out of service, turn off all peripheral devices connected to the system, turn off the system by pressing the power button, and unplug the AC power cord from the system or wall outlet.

The power supply can be replaced if it fails or if one of the fans that is integrated into it fails. To replace the power supply, follow these steps:

1. Disconnect all power cables.
2. Lift the power supply to disengage it from the latch (see letter “A” in [Figure 77](#)) and remove the power supply by sliding it out (see letter “B” in [Figure 77](#)).

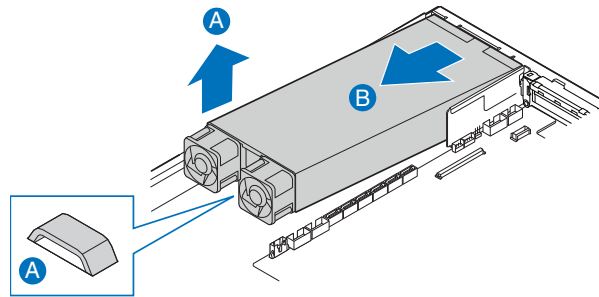

AF000366

Figure 77. Removing Power Supply Module from the Server System

3. Insert the replacement power supply module into the power supply cage until it clicks into place.

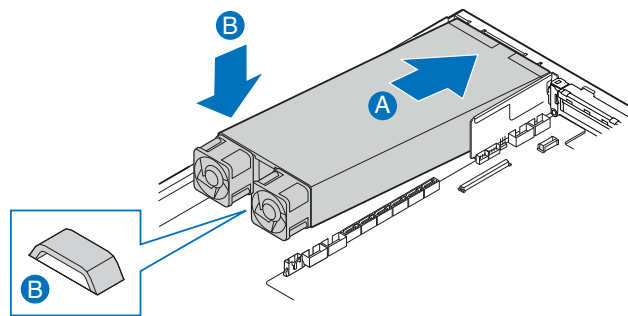

AF000367

Figure 78. Installing Power Supply Module into the Server System

4. Reconnect all power cables.

Replacing the Control Panel Module (Hot-swap Hard Drive System only)

Your server system must be operated with a control panel installed.

Note: The Intel® Local Control Panel is only supported in hot-swap hard drive systems.

Caution: The control panel is NOT hot-swappable. Before removing or replacing the control panel, you must first take the server out of service, turn off all peripheral devices connected to the system, turn off the system by pressing the power button, and unplug the AC power cord from the system or wall outlet.

1. Unplug the front panel and USB cables from the backplane (see letters “A” and “B” in [Figure 79](#)).
2. Press the latch at the back of the control panel and push it forward (see letter “C” in [Figure 79](#)).

- Slide the control panel out through the front of the server system (see letter “D” in Figure 79).

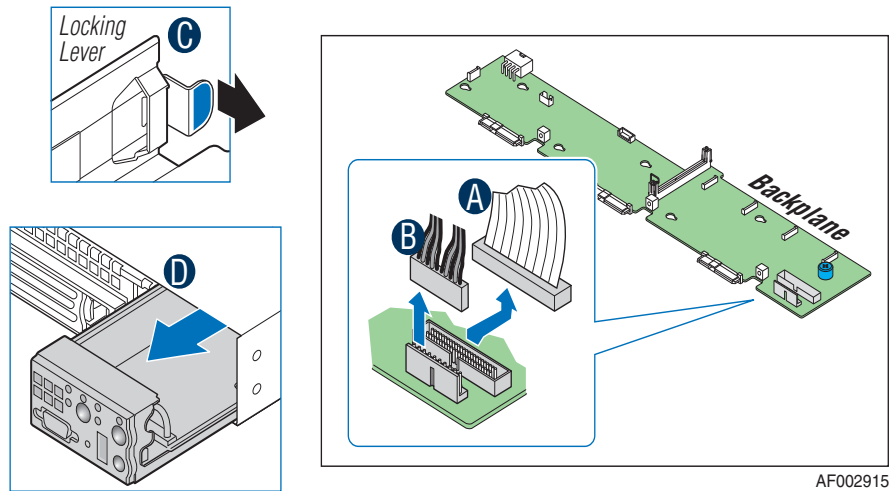

AF002915

Figure 79. Removing the Standard Control Panel Module

- Connect the USB and data cables to the local control panel (see letters “A” and “B” in Figure 80).
- Feed the control panel cables through the chassis opening (see letter “C” in Figure 80).
- Slide the replacement control panel into the server system (see letter “D” in Figure 80) until it clicks into place.
- Connect the two cables to the USB and front panel connectors on the backplane (see letters “E” and “F” in Figure 80).

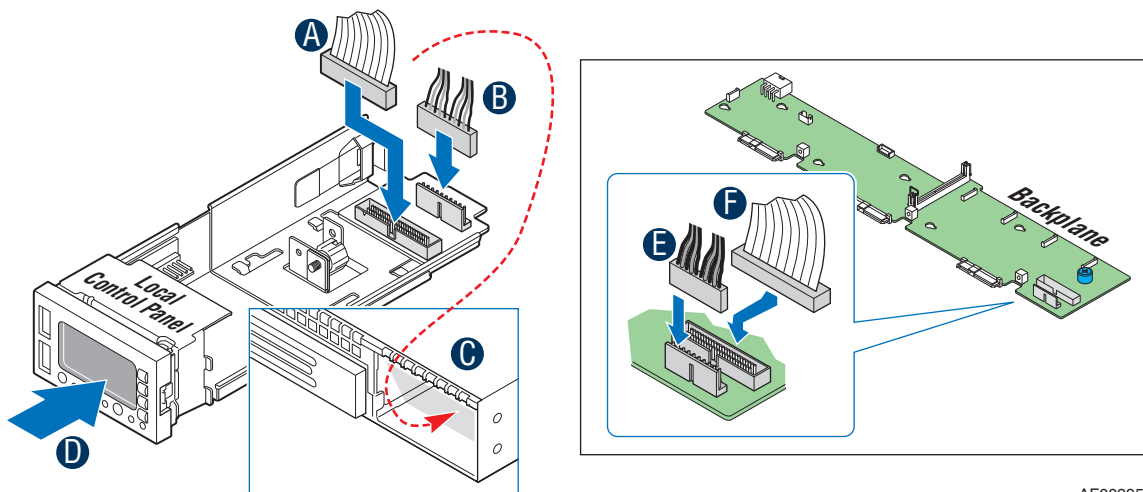

AF002950

Figure 80. Installing Control Panel Module into the Server System

Removing and Installing the Fan Assembly

Removing the System Fan Assembly

To remove the system fan assembly, follow these steps:

1. If installed, remove the PCI riser assembly. For instructions, see [“Removing the PCI Riser Assembly” on page 41](#).
2. If installed, remove the processor air duct. For instructions, see [“Removing the Processor Air Duct” on page 46](#).
3. Remove the small air baffle. For instructions, see [“Removing the Small Air Baffle” on page 56](#).
4. Remove the bridge board. For instructions, see step 4 in [“Removing the Backplane Board” on page 81](#)
5. Disconnect the fan power cables from the backplane board (see letter “A” in [Figure 81](#)).
6. Press latch (see letter “B” in [Figure 81](#)) and slide fan assembly to the left (see letter “C” in [Figure 81](#)).

7. Lift up to remove the fan assembly (see letter “D” in [Figure 81](#)).

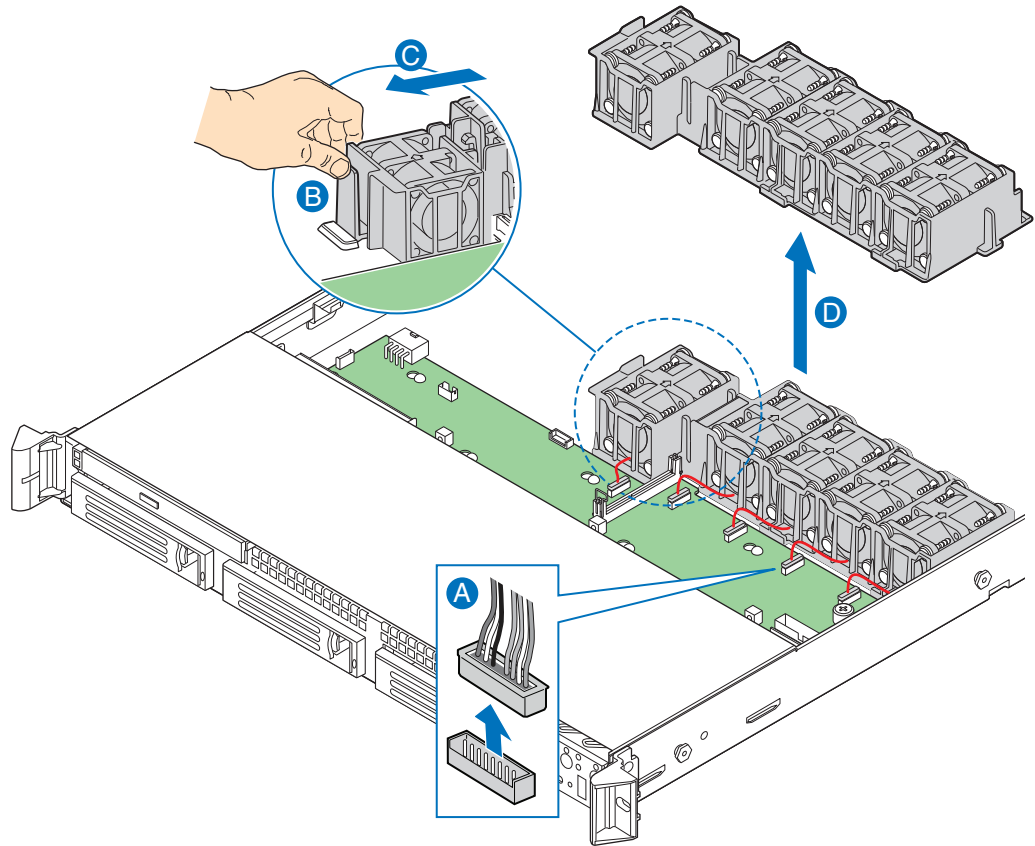

AF003020

Figure 81. Removing the Fan Assembly

Installing the System Fan Assembly

To install the system fan assembly, follow these steps:

1. Lower the system fan assembly into place (see letter “A” in [Figure 82](#)) and slide it to the right (see letter “B” in [Figure 82](#)).

2. Connect the fan cables to the backplane board (see letter “C” in [Figure 82](#)).

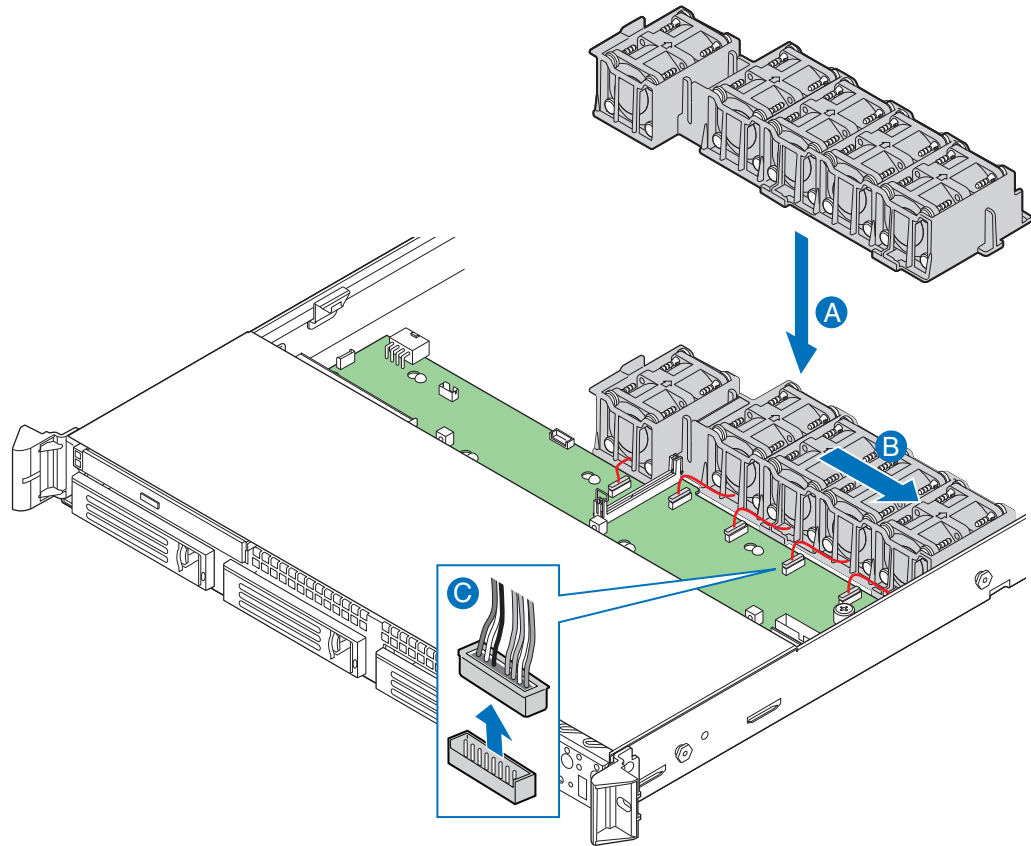

AF003031

Figure 82. Installing the System Fan Assembly

3. Install the bridge board. For instructions, see step 7 in “[Installing the Backplane Board](#)” on page 77.
4. Install the small air baffle. For instructions, see “[Installing the Small Air Baffle](#)” on page 56.
5. Install the processor air duct. For instructions, see “[Installing the Processor Air Duct](#)” on page 47.
6. Install the PCI riser assembly. For instructions, see “[Installing the PCI Riser Assembly](#)” on page 42.

Replacing a System Fan

Caution: The system fans are NOT hot-swappable. Before removing or replacing a fan, you must first take the server out of service, turn off all peripheral devices connected to the system, turn off the system by pressing the power button, and unplug the AC power cord from the system or wall outlet.

Note: The fans that are integrated into the power supply cannot be replaced separately. If one of the fans in the power supply fails, the power supply must be replaced.

The system fans at the front of the Intel® Server System SR1600UR can be individually replaced if one of them fails. Use the following steps to replace a dual rotor fan.

1. If installed, remove the PCI riser assembly. For instructions, see [“Removing the PCI Riser Assembly”](#) on page 41.
2. If installed, remove the processor air duct. For instructions, see [“Removing the Processor Air Duct”](#) on page 46.
3. Disconnect the fan cable from the backplane or fan board (see letter “A” in [Figure 83](#)).
4. Lift the failed fan from the module (see letter “B” in [Figure 83](#)).

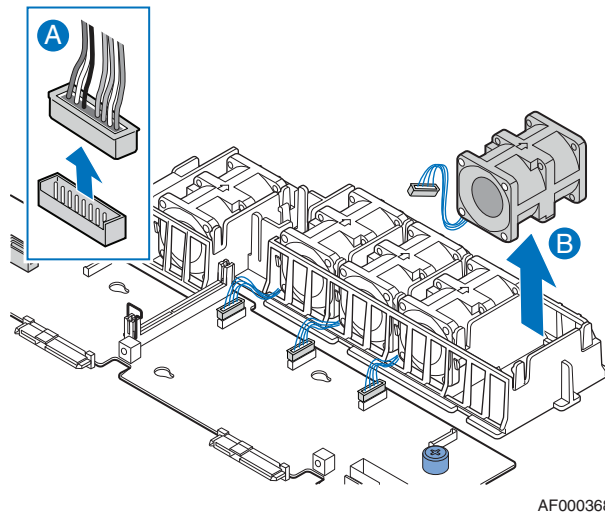
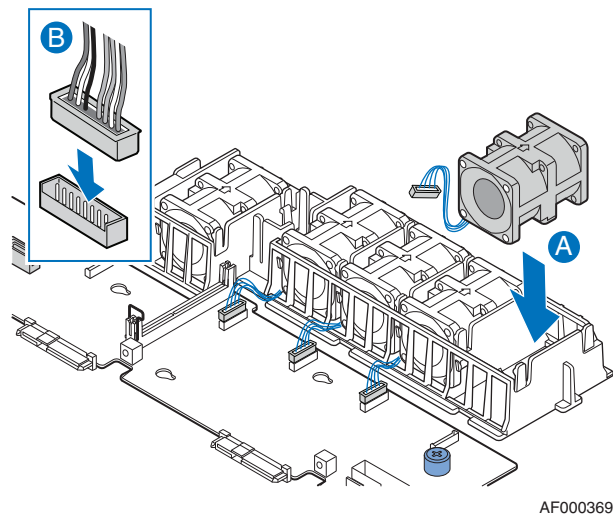

Figure 83. Removing a Fan from the Fan Module

5. Position the replacement fan so the connector on the fan is at the right and pointing down.
6. With the fan oriented correctly, insert the fan into the fan module (see letter “A” in [Figure 84](#)), and insert the fan cable into the matching connector on the backplane or fan board (see letter “B” in [Figure 84](#)).



AF000369

Figure 84. Installing a Fan into the Fan Module

Installing and Removing the Rack Handles

Installing the Rack Handles

Align the rack handle with the two holes on the side of the server system and attach the rack handle to the server system with two screws as shown in [Figure 85](#).

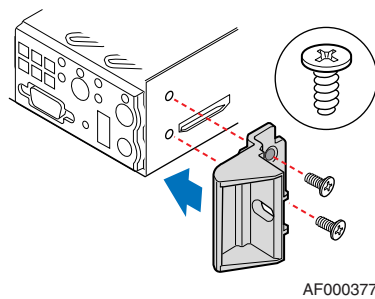

AF000377

Figure 85. Installing the Rack Handle

Removing the Rack Handles

Remove the two screws holding the rack handle in place, and remove the rack handle from the server system as shown in [Figure 86](#).

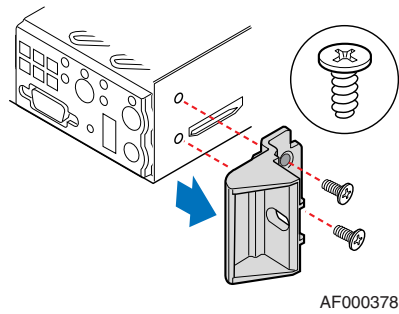

Figure 86. Removing the Rack Handle

4 Server Utilities

Using the BIOS Setup Utility

This section describes the BIOS Setup Utility options, which is used to change server configuration defaults. You can run BIOS Setup with or without an operating system being present. For information about specific BIOS setup screens, see the *Intel® Server Board S5520UR Technical Product Specification*. See [“Additional Information and Software” on page 3](#) for a web link to this document.

Entering BIOS Setup

To enter the BIOS Setup, press the F2 function key when prompted during boot time. You must ensure that all the jumpers are in the normal operating position.

The following prompt appears during the Power-On Self Test (POST) after POST completes the memory test:

```
Press <F2> to enter SETUP
```

When the BIOS setup is entered, the Main screen is displayed.

If You Cannot Access Setup

If you are not able to access the BIOS Setup, you might need to restore the BIOS default settings. For instructions, see [“Restoring the BIOS Defaults” on page 102](#).

Setup Menus

Each BIOS Setup menu page contains a number of features. Except for those features that are provided only to display automatically configured information, each feature is associated with a value field that contains user-selectable parameters. These parameters can be changed if the user has adequate security rights. If a value cannot be changed for any reason, the feature's value field is inaccessible.

The following table describes the keyboard commands you can use in the BIOS Setup menus.

Table 4. Setup Menu Key Use

Key to Press	Description
<F1>	Pressing <F1> on any menu invokes the general help window.

Table 4. Setup Menu Key Use

Key to Press	Description
Left and right arrows	Select Menu - The left and right arrow keys are used to move between the major menu pages. The keys have no affect if a submenu or pick list is displayed.
Up arrow	Select Item up - The up arrow is used to select the previous value in a menu item's option list, or a value field pick list. Pressing the <Enter> key activates the selected item.
Down arrow	Select Item down - The down arrow is used to select the next value in a menu item's option list, or a value field pick list. Pressing the <Enter> key activates the selected item.
<F5> or <->	Change Value - The minus key or the <F5> function key is used to change the value of the current item to the previous value. This key scrolls through the values in the associated pick list without displaying the full list.
<F6> or <+>	Change Value - The plus key or the <F6> function key is used to change the value of the current menu item to the next value. This key scrolls through the values in the associated pick list without displaying the full list. On 106-key Japanese keyboards, the plus key has a different scan code than the plus key on the other keyboard, but it has the same effect.
<Enter>	Execute Command - The <Enter> key is used to activate submenus when the selected feature is a submenu, or to display a pick list if a selected feature has a value field, or to select a sub-field for multi-valued features like time and date. If a pick list is displayed, the <Enter> key undoes the pick list, and allows another selection in the parent menu.
<Esc>	Exit - The <Esc> key provides a mechanism for backing out of any field. This key will undo the pressing of the <Enter> key. When the <Esc> key is pressed while editing any field or selecting features of a menu, the parent menu is re-entered. When the <Esc> key is pressed in any submenu, the parent menu is re-entered. When the <Esc> key is pressed in any major menu, the exit confirmation window is displayed and the user is asked whether changes can be discarded.
<F9>	<p>Setup Defaults - Pressing <F9> causes the following to appear:</p> <pre style="text-align: center;"> Setup Confirmation Load default configuration now? [Yes] [No] </pre> <p>If "Yes" is selected and the <Enter> key is pressed, all Setup fields are set to their default values. If "No" is selected and the <Enter> key is pressed, or if the <Esc> key is pressed, you are returned to the screen you were in before <F9> was pressed without affecting any existing field values.</p>

Table 4. Setup Menu Key Use

Key to Press	Description
<F10>	<p>Save and Exit - Pressing <F10> causes the following message to appear:</p> <pre> Setup Confirmation Save Configuration changes and exit now? [Yes] [No]</pre> <p>If "Yes" is selected and the <Enter> key is pressed, all changes are saved and Setup is exited. If "No" is selected and the <Enter> key is pressed, or the <Esc> key is pressed, you are returned to the screen you were in before <F10> was pressed without affecting any existing values.</p>

Upgrading the BIOS

The upgrade utility allows you to upgrade the BIOS in flash memory. The code and data in the upgrade file include the following:

- On-board system BIOS, including the recovery code, BIOS Setup Utility, and strings.
- On-board video BIOS, and other option ROMs for devices embedded on the server board.
- OEM binary area
- Microcode
- A way to change the BIOS language

Preparing for the Upgrade

The steps below explain how to prepare to upgrade the BIOS, including how to record the current BIOS settings and how to obtain the upgrade utility.

Note: *In the unlikely event that a BIOS error occurs during the BIOS update process, a recovery process may need to be followed to return the system to service. See “[Additional Information and Software](#)” on page 3 for a web link to necessary software and instructions.*

Recording the Current BIOS Settings

1. Boot the computer and press <F2> when you see the message:
Press <F2> Key if you want to run SETUP
2. Write down the current settings in the BIOS Setup program.

Note: Do not skip step 2. You will need these settings to configure your server at the end of the procedure.

Obtaining the Upgrade

Download the BIOS image file to a temporary folder on your hard drive. See [“Additional Information and Software” on page 3](#) for a web link to the update software.

Note: Review the instructions and release notes that are provided in the readme file distributed with the BIOS image file before attempting a BIOS upgrade. The release notes contain critical information regarding jumper settings, specific fixes, or other information to complete the upgrade.

Upgrading the BIOS

Follow the instructions in the readme file that came with the BIOS upgrade. When the update completes, remove the bootable media from which you performed the upgrade.

Caution: Do not power down the system during the BIOS update process! The system will reset automatically when the BIOS update process is completed.

Note: You may encounter a CMOS Checksum error or other problem after reboot. If this happens, shut down the system and boot it again. CMOS checksum errors require that you enter Setup, load BIOS defaults, check your settings, save your settings, and exit Setup.

Clearing the Password

If the user or administrator password(s) is lost or forgotten, moving the password clear jumper into the "clear" position clears both passwords. The password clear jumper must be restored to its original position before a new password(s) can be set.

1. Power down the system; do not disconnect the AC power.
2. Open the server system. For instructions on removing the system cover, see [“Removing the System Cover” on page 38](#).
3. Locate the Password Clear jumper block at board position J1E8.
4. Move the jumper from the normal operation position, that is, Password Clear Protect position (covering pins 1 and 2) to the Password Clear Erase position (covering pins 2 and 3).

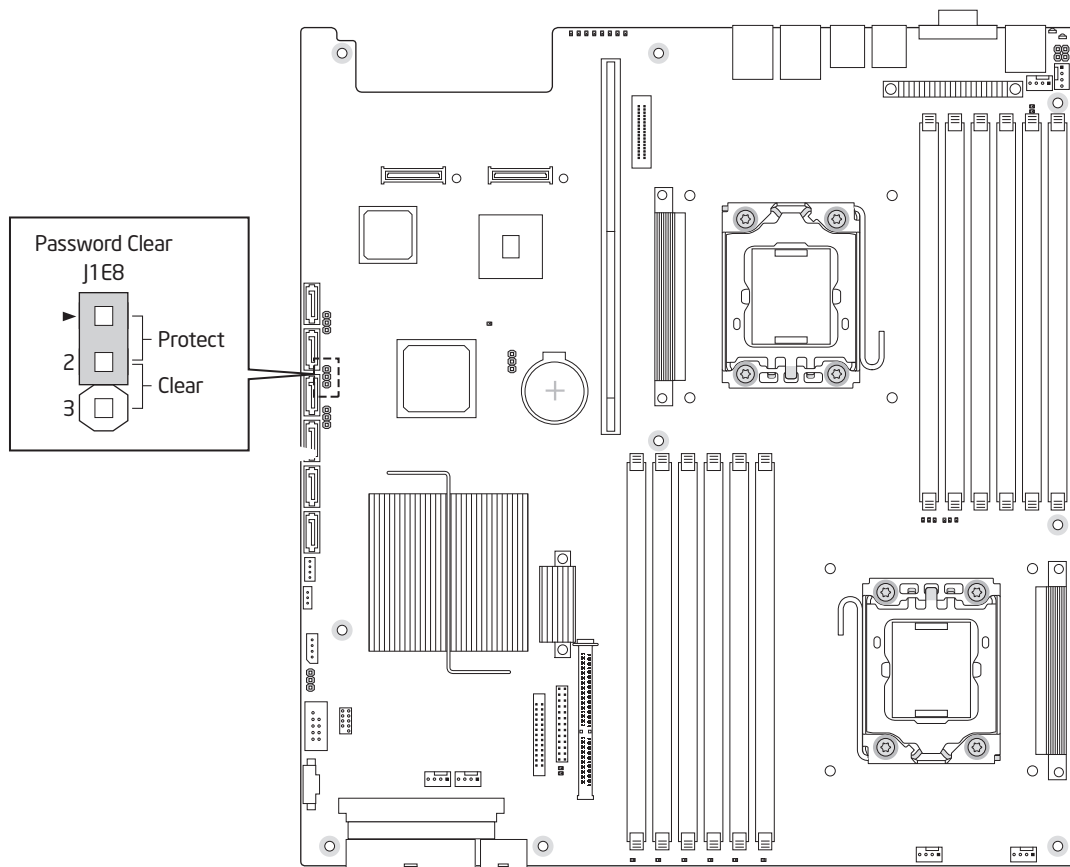

AF003112

Figure 87. Password Clear Jumper

5. Wait ten seconds.
6. Return the Password Clear jumper to the Password Clear Protect position (covering pins 1 and 2).
7. Close the server system.
8. Power up the server.

The password is now cleared and can be reset by going into BIOS setup.

Restoring the BIOS Defaults

If you need to restore the BIOS default settings, the BIOS Default jumper will need to be used.

1. Power down the system; do not disconnect the AC power.
2. Open the server system. For instructions on removing the system cover, see [“Removing the System Cover”](#) on page 38.
3. Locate the BIOS Default jumper block at board position J1E7.
4. Move the jumper from the normal operation position (covering pins 1 and 2) to the Set Default position (covering pins 2 and 3).

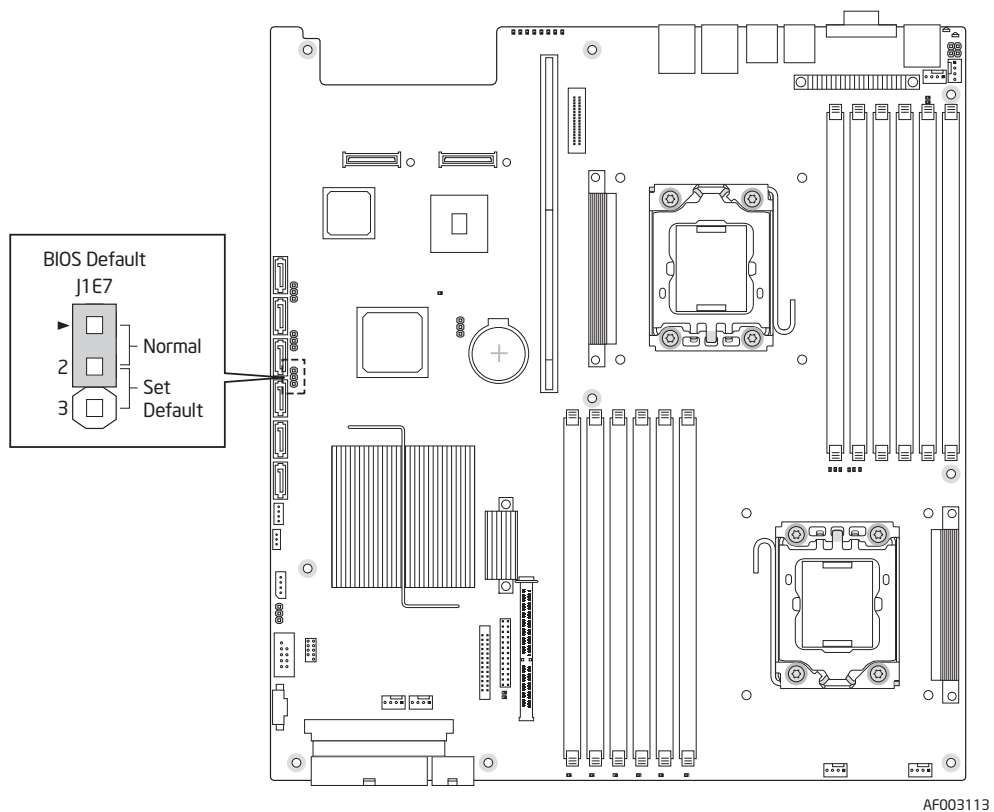

Figure 88. BIOS Default Jumper

5. Wait five seconds.
6. Return the BIOS Default jumper to the normal position (covering pins 1 and 2).
7. Close the server system.
8. Power up the system.

The BIOS defaults settings are now restored and can be reset by going into the BIOS setup.

Appendix A: Technical Reference

600-W Single Power Supply Input Voltages

The power supply must operate within all specified limits over the input voltage range shown in the following table.

Table 5. Power Supply Input Voltages

Parameter	Minimum	Rated	Maximum	Startup VAC	Power-off VAC	Maximum Input AC Current	Maximum Rated Input AC Current
Voltage (110)	90 V _{rms}	100-127 V _{rms}	140 V _{rms}	85 VAC +/- 4 VAC	75 VAC +/- 5 VAC	9.5 A _{rms} ^{1,3}	8.55 A _{rms} ⁴
Voltage (220)	180 V _{rms}	200-240 V _{rms}	264 V _{rms}			4.75 A _{rms} ^{2,3}	4.3 A _{rms} ⁴
Frequency	47 Hz	50/60 Hz	63 Hz				

Note: Maximum input current at low input voltage range is measured at 90 VAC, at maximum load.

Maximum input current at high input voltage range is measured at 180 VAC, at maximum load.

This is not to be used for determining agency input current markings.

Maximum rated input current is measured at 100 VAC and 200 VAC.

600-W Single Power Supply Output Voltages

The following table lists the total wattage available from the power subsystem for each voltage. Ensure that your loads do not exceed the combined total wattage of 600 Watts.

Table 6. Power Supply Output Capability

Voltage	Minimum OCP Limits	Maximum OCP Limits
+3.3 V	115%	150%
+5.0 V	115%	150%
+12.0 V1	18.5 A	20 A
+12.0 V2	18.5 A	20 A
-12.0 V3	25 A	30 A
+12.0 V4	18.5 A	20 A
-12.0 V	0.7 A	3.0 A
5.0 VSB	115%	6 A

Warning: Do not exceed a combined power output of 90 Watts for the +5 V and +3.3 V outputs. Exceeding a combined 90 Watts will overload the power subsystem and may cause the power supplies to overheat and malfunction.

System Environmental Specifications

Table 7. System Environmental Specifications

Temperature	
Non-operating	-40° to 70°C.
Operating	10°C to 35°C with the maximum rate of change not to exceed 10°C per hour
Humidity	
Non-operating	90% relative humidity (non-condensing) at 35°C.
Shock	
Operating	2.0 g, 11 msec, half sine
Packaged	Non-palletized free fall in height 24 inches (> 40 lbs to < 80 lbs)
Unpackaged	Trapezoidal, 25 g, velocity change 136 inches/sec (> 40 lbs to < 80 lbs)
Acoustic noise	Sound Power: 7.0 BA in an idle state at typical office ambient temperature (23 +/- 2°C).
Electrostatic discharge (ESD)	+/-15 KV except I/O port +/- 8 KV per Intel® Environment test specification.
System Cooling Requirement in BTU/Hr	2550 BTU/Hr

Appendix B: Intel® Server Issue Report Form

Issue Report Form (Rev 3.6)

Note: *Filling out this form completely is required for any escalation.*

Customer Contact Information:

Customer Support Case #:

Intel® Server Board or System:

(Example : S5000PSL or SR6850HW4)

Server Chassis:

(Example SC5400. If third-party chassis used, indicate make and model.)

Baseboard Information: (some information maybe found by accessing BIOS & going through the Server Management menu -> System Information)

Baseboard PBA/TA/AA # (Example: 123456-789):

- can be found on the white sticker label on the baseboard

System BIOS Version:

Intel® Remote Management Module Firmware Version (if applicable):

Intel® Management Module BMC Revision (if applicable) :

BMC/mBMC Version:

FRU/SDR Version:

HSC Version:

Has the latest BIOS been tried? (Yes/No):

Has the latest BMC/mBMC been tried? (Yes/No):

Has the latest IMM BMC been tried? (Yes/No):

Has the latest RMM Firmware been tried? (Yes/No):

Has the latest FRU/SDR been tried? (Yes/No):

Has the latest HSC been tried? (Yes/No):

=====

Processor information:

	Type	Speed	sSpec	Thermal Solution
Processor 1				
Processor 2				
Processor 3				
Processor 4				

Thermal solution (Heatsink) examples:

(1U, Passive w/air ducting, Active w/fan, etc.)

=====

Memory:

Manufacturer	Part Number	DRAM Part Number	On Intel tested list?

Add-in adapters (Example: NICs, Management Adapters, Serial Expansion Cards, PCI-Express* Adapters, RAID Controllers, SCSI Controllers, etc.):

Type	Slot	Manufacturer	Model	Firmware

Third party hardware (Example: Example: KVM, Chassis, etc):

Description/Use	Manufacturer	Model	Firmware

Storage Devices (Example: SCSI, SATA, SAS, USB, Tape, etc.):

Manufacturer	Model	Type	Size	Firmware	In Hot-Swap Bay?

Operating System Information (Example: RedHat* Enterprise Linux, Microsoft* Windows* Server 2003, Service pack 1, OEM CD):

Manufacturer:

Version:

Language version (English, Arabic, Chinese (Simplified)):

Service Pack Level or Kernel Revision:

Distribution (OEM/Retail):

Intel® RAID Controller: (Example SRCU42E)

RAID controller part number (PBA number):

RAID controller firmware version:

Has the latest RAID firmware been tried? (Yes/No):

RAID driver version:

Has the latest RAID driver been tried? (Yes/No):

RAID volumes configuration (disks & RAID level):

RAID volume use (Boot device/Data Volume):

Is BBU (Battery Backup Unit) installed? (Yes/No):

BBU part number:
=====

Detailed description of issue:

Troubleshooting tried:

Steps to replicate the issue:

Issue impact statements:

Do you have any potential Intel system, or component purchases that this issue is holding up? If yes, please provide a brief description below.

Do you have systems already purchased that are not being delivered to your customers because of this issue? If yes, please provide a brief description below.

Have you returned systems or components to your place of purchase because of this issue? If yes, please provide a brief description below.

*All other brands and names are property of their respective owners.

Appendix C: LED Decoder

During the system boot process, the BIOS executes a number of platform configuration processes, each of which is assigned a specific hex POST code number. As each configuration routine is started, the BIOS displays the POST code to the POST Code Diagnostic LEDs found on the back edge of the server board. To assist in troubleshooting a system hang during the POST process, the Diagnostic LEDs can be used to identify the last POST process to be executed.

Each POST code is represented by the eight amber Diagnostic LEDs. The POST codes are divided into two nibbles, an upper nibble and a lower nibble. The upper nibble bits are represented by Diagnostic LEDs #4, #5, #6, #7. The lower nibble bits are represented by Diagnostics LEDs #0, #1, #2 and #3. If the bit is set in the upper and lower nibbles, then the corresponding LED is lit. If the bit is clear, then the corresponding LED is off.

The Diagnostic LED #7 is labeled as "MSB", and the Diagnostic LED #0 is labeled as "LSB".

In the following example, the BIOS sends a value of ACh to the diagnostic LED decoder. The LEDs are decoded as follows:

- "Upper nibble bits = 1010b = Ah;
- Lower nibble bits = 1100b = Ch;

The two are concatenated as ACh.

Table 8. POST Progress Code LED Example

LEDs	Upper Nibble LEDs				Lower Nibble LEDs			
	MSB							LSB
	LED #7	LED #6	LED #5	LED #4	LED #3	LED #2	LED #1	LED #0
	8h	4h	2h	1h	8h	4h	2h	1h
Status	ON	OFF	ON	OFF	ON	ON	OFF	OFF
Result	1	0	1	0	1	1	0	0
	Ah				Ch			

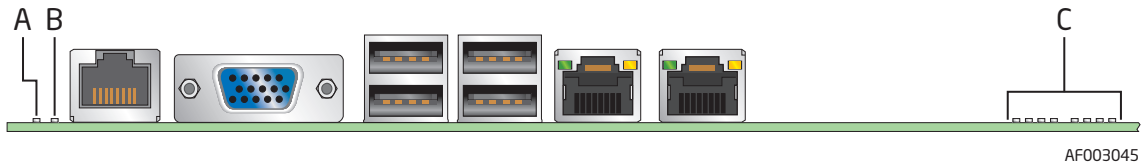

A. System Status LED	B. System Identification LED
C. POST Code Diagnostic LEDs	

Figure 89. Diagnostic LED Placement Diagram

Table 9. Diagnostic LED POST Code Decoder

Checkpoint	Diagnostic LED Decoder								Description
	O=On; X=Off								
	Upper Nibble				Lower Nibble				
	MSB							LSB	
	8h	4h	2h	1h	8h	4h	2h	1h	
LED	#7	#6	#5	#4	#3	#2	#1	#0	
Multi-Use Code (This beep code is used in different contexts)									
0xF2h	O	O	O	O	X	X	O	X	Seen at the start of Memory Reference Code (MRC)
									Start of the very early platform initialization code
									Very late in POST, it is the signal that the OS has switched to virtual memory mode
Memory Error Codes (Accompanied by a beep code)									
0xE8h	O	O	O	X	O	X	X	X	No Usable Memory Error: No memory in the system, or SPD bad so no memory could be detected
0xEAh	O	O	O	X	O	X	O	X	Channel Training Error: DQ/DQS training failed on a channel during memory channel initialization.
0xEBh	O	O	O	X	O	X	O	O	Memory Test Error: memory failed Hardware BIST.

Table 9. Diagnostic LED POST Code Decoder

Checkpoint	Diagnostic LED Decoder								Description
	0=On; X=Off								
	Upper Nibble				Lower Nibble				
	MSB							LSB	
	8h	4h	2h	1h	8h	4h	2h	1h	
LED	#7	#6	#5	#4	#3	#2	#1	#0	
0xEDh	O	O	O	X	O	O	X	O	Population Error: RDIMMs and UDIMMs cannot be mixed in the system
0xEEh	O	O	O	X	O	O	O	X	Mismatch Error: more than 2 Quad Ranked DIMMS in a channel.
Memory Reference Code Progress Codes (Not accompanied by a beep code)									
0xB0h	O	X	O	O	X	X	X	X	Chipset Initialization Phase
0xB1h	O	X	O	O	X	X	X	O	Reset Phase
0xB2h	O	X	O	O	X	X	O	X	DIMM Detection Phase
0xB3h	O	X	O	O	X	X	O	O	Clock Initialization Phase
0xB4h	O	X	O	O	X	O	X	X	SPD Data Collection Phase
0xB6h	O	X	O	O	X	O	O	X	Rank Formation Phase
0xB8h	O	X	O	O	O	X	X	X	Channel Training Phase
0xB9h	O	X	O	O	O	X	X	O	Memory Test Phase
0xBAh	O	X	O	O	O	X	O	X	Memory Map Creation Phase
0xBBh	O	X	O	O	O	X	O	O	RAS Initialization Phase
0xBFh	O	X	O	O	O	O	O	O	MRC Complete
Host Processor									
0x04h	X	X	X	X	X	O	X	X	Early processor initialization where system BSP is selected
0x10h	X	X	X	O	X	X	X	X	Power-on initialization of the host processor (bootstrap processor)
0x11h	X	X	X	O	X	X	X	O	Host processor cache initialization (including AP)
0x12h	X	X	X	O	X	X	O	X	Starting application processor initialization
0x13h	X	X	X	O	X	X	O	O	SMM initialization

Table 9. Diagnostic LED POST Code Decoder

Checkpoint	Diagnostic LED Decoder								Description
	0=On; X=Off								
	Upper Nibble				Lower Nibble				
	MSB							LSB	
	8h	4h	2h	1h	8h	4h	2h	1h	
LED	#7	#6	#5	#4	#3	#2	#1	#0	
Chipset									
0x21h	X	X	O	X	X	X	X	O	Initializing a chipset component
Memory									
0x22h	X	X	O	X	X	X	O	X	Reading configuration data from memory (SPD on DIMM)
0x23h	X	X	O	X	X	X	O	O	Detecting presence of memory
0x24h	X	X	O	X	X	O	X	X	Programming timing parameters in the memory controller
0x25h	X	X	O	X	X	O	X	O	Configuring memory parameters in the memory controller
0x26h	X	X	O	X	X	O	O	X	Optimizing memory controller settings
0x27h	X	X	O	X	X	O	O	O	Initializing memory, such as ECC init
0x28h	X	X	O	X	O	X	X	X	Testing memory
PCI Bus									
0x50h	X	O	X	O	X	X	X	X	Enumerating PCI buses
0x51h	X	O	X	O	X	X	X	O	Allocating resources to PCI buses
0x52h	X	O	X	O	X	X	O	X	Hot Plug PCI controller initialization
0x53h	X	O	X	O	X	X	O	O	Reserved for PCI bus
0x54h	X	O	X	O	X	O	X	X	Reserved for PCI bus
0x55h	X	O	X	O	X	O	X	O	Reserved for PCI bus
0x56h	X	O	X	O	X	O	O	X	Reserved for PCI bus
0x57h	X	O	X	O	X	O	O	O	Reserved for PCI bus
USB									
0x58h	X	O	X	O	O	X	X	X	Resetting USB bus
0x59h	X	O	X	O	O	X	X	O	Reserved for USB devices

Table 9. Diagnostic LED POST Code Decoder

Checkpoint	Diagnostic LED Decoder								Description
	0=On; X=Off								
	Upper Nibble				Lower Nibble				
	MSB							LSB	
	8h	4h	2h	1h	8h	4h	2h	1h	
LED	#7	#6	#5	#4	#3	#2	#1	#0	
ATA/ATAPI/SATA									
0x5Ah	X	O	X	O	O	X	O	X	Resetting SATA bus and all devices
0x5Bh	X	O	X	O	O	X	O	O	Reserved for ATA
SMBUS									
0x5Ch	X	O	X	O	O	O	X	X	Resetting SMBUS
0x5Dh	X	O	X	O	O	O	X	O	Reserved for SMBUS
Local Console									
0x70h	X	O	O	O	X	X	X	X	Resetting the video controller (VGA)
0x71h	X	O	O	O	X	X	X	O	Disabling the video controller (VGA)
0x72h	X	O	O	O	X	X	O	X	Enabling the video controller (VGA)
Remote Console									
0x78h	X	O	O	O	O	X	X	X	Resetting the console controller
0x79h	X	O	O	O	O	X	X	O	Disabling the console controller
0x7Ah	X	O	O	O	O	X	O	X	Enabling the console controller
Keyboard (USB only)									
0x90h	O	X	X	O	X	X	X	X	Resetting the keyboard
0x91h	O	X	X	O	X	X	X	O	Disabling the keyboard
0x92h	O	X	X	O	X	X	O	X	Detecting the presence of the keyboard
0x93h	O	X	X	O	X	X	O	O	Enabling the keyboard
0x94h	O	X	X	O	X	O	X	X	Clearing keyboard input buffer
0x95h	O	X	X	O	X	O	X	O	Instructing keyboard controller to run Self Test (PS2 only)
Mouse (USB only)									

Table 9. Diagnostic LED POST Code Decoder

Checkpoint	Diagnostic LED Decoder								Description
	0=On; X=Off								
	Upper Nibble				Lower Nibble				
	MSB							LSB	
	8h	4h	2h	1h	8h	4h	2h	1h	
LED	#7	#6	#5	#4	#3	#2	#1	#0	
0x98h	O	X	X	O	O	X	X	X	Resetting the mouse
0x99h	O	X	X	O	O	X	X	O	Detecting the mouse
0x9Ah	O	X	X	O	O	X	O	X	Detecting the presence of mouse
0x9Bh	O	X	X	O	O	X	O	O	Enabling the mouse
Fixed Media									
0xB0h	O	X	O	O	X	X	X	X	Resetting fixed media device
0xB1h	O	X	O	O	X	X	X	O	Disabling fixed media device
0xB2h	O	X	O	O	X	X	O	X	Detecting presence of a fixed media device (hard drive detection, etc.)
0xB3h	O	X	O	O	X	X	O	O	Enabling/configuring a fixed media device
Removable Media									
0xB8h	O	X	O	O	O	X	X	X	Resetting removable media device
0xB9h	O	X	O	O	O	X	X	O	Disabling removable media device
0xBAh	O	X	O	O	O	X	O	X	Detecting presence of a removable media device (CDROM detection, etc.)
0xBCh	O	X	O	O	O	O	X	X	Enabling/configuring a removable media device
Boot Device Selection (BDS)									
0xD0	O	O	X	O	X	X	X	X	Trying to boot device selection 0
0xD1	O	O	X	O	X	X	X	O	Trying to boot device selection 1
0xD2	O	O	X	O	X	X	O	X	Trying to boot device selection 2
0xD3	O	O	X	O	X	X	O	O	Trying to boot device selection 3
0xD4	O	O	X	O	X	O	X	X	Trying to boot device selection 4
0xD5	O	O	X	O	X	O	X	O	Trying to boot device selection 5

Table 9. Diagnostic LED POST Code Decoder

Checkpoint	Diagnostic LED Decoder								Description
	0=On; X=Off								
	Upper Nibble				Lower Nibble				
	MSB							LSB	
	8h	4h	2h	1h	8h	4h	2h	1h	
LED	#7	#6	#5	#4	#3	#2	#1	#0	
0xD6	O	O	X	O	X	O	O	X	Trying to boot device selection 6
0xD7	O	O	X	O	X	O	O	O	Trying to boot device selection 7
0xD8	O	O	X	O	O	X	X	X	Trying to boot device selection 8
0xD9	O	O	X	O	O	X	X	O	Trying to boot device selection 9
0xDA	O	O	X	O	O	X	O	X	Trying to boot device selection A
0xDB	O	O	X	O	O	X	O	O	Trying to boot device selection B
0xDC	O	O	X	O	O	O	X	X	Trying to boot device selection C
0xDD	O	O	X	O	O	O	X	O	Trying to boot device selection D
0xDE	O	O	X	O	O	O	O	X	Trying to boot device selection E
0xDF	O	O	X	O	O	O	O	O	Trying to boot device selection F
Pre-EFI Initialization (PEI) Core									
0xE0h	O	O	O	X	X	X	X	X	Started dispatching early initialization modules (PEIM)
0xE1h	O	O	O	X	X	X	X	O	Reserved for initialization module use (PEIM)
0xE2h	O	O	O	X	X	X	O	X	Initial memory found, configured, and installed correctly
0xE3h	O	O	O	X	X	X	O	O	Reserved for initialization module use (PEIM)
Driver Execution Environment (DXE) Core (not accompanied by a beep code)									
0xE4h	O	O	O	X	X	O	X	X	Entered EFI driver execution (DXE) phase
0xE5h	O	O	O	X	X	O	X	O	Started dispatching drivers
0xE6h	O	O	O	X	X	O	O	X	Started connecting drivers
DXE Drivers									
0xE7h	O	O	O	X	O	O	X	O	Waiting for user input

Table 9. Diagnostic LED POST Code Decoder

Checkpoint	Diagnostic LED Decoder								Description
	0=On; X=Off								
	Upper Nibble				Lower Nibble				
	MSB							LSB	
	8h	4h	2h	1h	8h	4h	2h	1h	
LED	#7	#6	#5	#4	#3	#2	#1	#0	
0xE8h	O	O	O	X	O	X	X	X	Checking password
0xE9h	O	O	O	X	O	X	X	O	Entering BIOS setup
0xEAh	O	O	O	X	O	X	O	X	Flash Update
0xEEh	O	O	O	X	O	O	O	X	Calling Int 19. One beep unless silent boot is enabled.
0xEFh	O	O	O	X	O	O	O	O	Unrecoverable boot failure
Runtime Phase/EFI Operating System Boot									
0xF2h	O	O	O	O	X	X	O	X	Signal that the OS has switched to virtual memory mode
0xF4h	O	O	O	O	X	O	X	X	Entering Sleep state
0xF5h	O	O	O	O	X	O	X	O	Exiting Sleep state
0xF8h	O	O	O	O	O	X	X	X	OS has requested EFI to close boot services (ExitBootServices () has been called)
0xF9h	O	O	O	O	O	X	X	O	OS has switched to virtual address mode (SetVirtualAddressMap () has been called)
0xFAh	O	O	O	O	O	X	O	X	OS has requested the system to reset (ResetSystem () has been called)
Pre-EFI Initialization Module (PEIM)/Recovery									
0x30h	X	X	O	O	X	X	X	X	Crisis recovery has been initiated because of a user request
0x31h	X	X	O	O	X	X	X	O	Crisis recovery has been initiated by software (corrupt flash)
0x34h	X	X	O	O	X	O	X	X	Loading crisis recovery capsule
0x35h	X	X	O	O	X	O	X	O	Handing off control to the crisis recovery capsule
0x3Fh	X	X	O	O	O	O	O	O	Unable to complete crisis recovery capsule

Appendix D: Getting Help

If you encounter an issue with your server system, follow these steps to obtain support:

1. Visit the following Intel support web page:
http://www.intel.com/p/en_US/support/server
This web page provides 24x7 support when you need it to get the latest and most complete technical support information on all Intel Enterprise Server and Storage Platforms. Information available at the support site includes:
 - Latest BIOS, firmware, drivers and utilities
 - Product documentation, installation and quick start guides
 - Full product specifications, technical advisories and errata
 - Compatibility documentation for memory, hardware add-in cards, chassis support matrix and operating systems
 - Server and chassis accessory parts list for ordering upgrades or spare parts
 - A searchable knowledgebase to search for product information throughout the support site
2. If you are still unable to obtain a solution to your issue, send an email to Intel's technical support center using the online form available at <http://supportmail.intel.com/scripts-emf/welcome.aspx>
3. Lastly, you can contact an Intel support representative using one of the support phone numbers available at <http://support.intel.com/support/9089.htm> (charges may apply). Intel customer support suggests filling out the issue report form available at “[Intel® Server Issue Report Form](#)” on page 107 to better service the issue.
Intel also offers Channel Program members around-the-clock 24x7 technical phone support on Intel® server boards, server chassis, server RAID controller cards, and Intel® Server Management at <http://www.intel.com/reseller/>.

Note: You will need to log in to the Reseller site to obtain the 24x7 number.

Warranty Information

To obtain warranty information, visit the following Intel web site:
<http://www.intel.com/support/motherboards/server/sb/CS-010807.htm>.

Appendix E: Regulatory and Certification Information

Warning: *To ensure regulatory compliance, you must adhere to the assembly instructions in this guide to ensure and maintain compliance with existing product certifications and approvals. Use only the described, regulated components specified in this guide. Use of other products/components will void the UL listing and other regulatory approvals of the product and will most likely result in noncompliance with product regulations in the region(s) in which the product is sold.*

To help ensure EMC compliance with your local regional rules and regulations, before computer integration, make sure that the server system, power supply, and other modules have passed EMC testing using a server board with a microprocessor from the same family (or higher) and operating at the same (or higher) speed as the microprocessor used on this server board. The final configuration of your end system product may require additional EMC compliance testing. For more information, please contact your local Intel representative.

This is an FCC Class A device. Integration of it into a Class B system does not result in a Class B device.

Product Regulatory Compliance

This server chassis product, when correctly integrated per this guide, complies with the following safety and electromagnetic compatibility (EMC) regulations.

Intended Application - This product was evaluated as Information Technology Equipment (ITE), which may be installed in offices, schools, computer rooms, and similar commercial type locations. The suitability of this product for other product categories and environments (such as: medical, industrial, telecommunications, NEBS, residential, alarm systems, test equipment, etc.), other than an ITE application, may require further evaluation.

Product Safety Compliance

- UL60950 - CSA 60950 (USA/Canada)
- EN60950 (Europe)
- IEC60950 (International)
- CB Certificate & Report, IEC60950 (report to include all country national deviations)
- GS Certification (Germany)

- GOST R 50377-92 - Certification (Russia)
- Belarus Certification (Belarus)
- Ukraine Certification (Ukraine)
- CE - Low Voltage Directive 73/23/EEE (Europe)
- IRAM Certification (Argentina)

Product EMC Compliance - Class A Compliance

- FCC /ICES-003 - Emissions (USA/Canada) Verification
- CISPR 22 - Emissions (International)
- EN55022 - Emissions (Europe)
- EN55024 - Immunity (Europe)
- EN61000-3-2 - Harmonics (Europe)
- EN61000-3-3 - Voltage Flicker (Europe)
- CE - EMC Directive 89/336/EEC (Europe)
- VCCI Emissions (Japan)
- AS/NZS 3548 Emissions (Australia/New Zealand)
- BSMI CNS13438 Emissions (Taiwan)
- GOST R 29216-91 Emissions (Russia)
- GOST R 50628-95 Immunity (Russia)
- Belarus Certification (Belarus)
- Ukraine Certification (Ukraine)
- KCC Certification (EMI) (Korea)

Product Ecology Compliance

Intel has a system in place to restrict the use of banned substances in accordance with world wide regulatory requirements. A Material Declaration Data Sheet is available for Intel products. For more reference on material restrictions and compliance you can view Intel's Environmental Product Content Specification at <http://supplier.intel.com/ehs/environmental.htm>.

- Europe - European Directive 2002/95/EC - Restriction of Hazardous Substances (RoHS)
Threshold limits and banned substances are noted below.
Quantity limit of 0.1% by mass (1000 PPM) for:
Lead, Mercury, Hexavalent Chromium, Polybrominated Biphenyls Diphenyl Ethers (PBB/PBDE)
Quantity limit of 0.01% by mass (100 PPM) for:
Cadmium
- California Code of Regulations, Title 22, Division 4.5, Chapter 33:
Best Management Practices for Perchlorate Materials
- China - Restriction of Hazardous Substances (China RoHS)
- WEEE Directive (Europe)
- Packaging Directive (Europe)

Certifications/Registrations/Declarations

- NRTL Certification (US/Canada)
- CE Declaration of Conformity (CENELEC Europe)
- FCC/ICES-003 Class A Attestation (USA/Canada)
- VCCI Certification (Japan)
- C-Tick Declaration of Conformity (Australia)
- MED Declaration of Conformity (New Zealand)
- BSMI Certification (Taiwan)
- GOST R Certification/Certification (Russia)
- Belarus Certification/Certification (Belarus)
- KCC Certification (Korea)
- IRAM Certification (Argentina)
- Ecology Declaration (International)
- China RoHS Environmental Friendly Use Period
- Packaging & Product Recycling Marks

Product Regulatory Compliance Markings

This Intel Server Chassis product is provided with the following regulatory and safety markings. In the event there is no room for a marking(s) on the chassis, the information is provided here in this guide.

Table 10. Product Regulatory Compliance Markings



Regulatory Compliance	Country	Marking
cULus Listing Marks	USA/Canada	
GS Mark	Germany	
CE Mark	Europe	
FCC Marking (Class A)	USA	This device complies with Part 15 of the FCC Rules. Operation of this device is subject to the following two conditions: (1) This device may not cause harmful interference, and (2) This device must accept any interference received, including interference that may cause undesired operation. Manufactured by Intel Corporation
EMC Marking (Class A)	Canada	CANADA ICES-003 CLASS A CANADA NMB-003 CLASSE A
VCCI Marking (Class A)	Japan	この装置は、クラス A 情報技術装置です。この装置を家庭環境で使用すると電波妨害を引き起こすことがあります。この場合には使用者が適切な対策を講ずるよう要求されることがあります。VCCI-A

Table 10. Product Regulatory Compliance Markings

Regulatory Compliance	Country	Marking
BSMI Certification Number & Class A Warning	Taiwan	 <p data-bbox="906 527 1263 617">警告使用者： 這是甲類的資訊產品，在居住的環境中使用時，可能會造成射頻干擾，在這種情況下，使用者會被要求採取某些適當的對策</p>
GOST R Marking	Russia	
KCC Mark (Korean Communications Commission)	Korea	 <p data-bbox="906 1062 1078 1094">방송통신위원회</p>
Belarus Safety Compliance Mark	Belarus	
Waste of Electronic and Electrical Equipment Recycling Mark	Europe	
China Restriction of Hazardous Substance Environmental Friendly Use Period Mark	China	

Table 10. Product Regulatory Compliance Markings





Regulatory Compliance	Country	Marking
China Recycling Mark	China	
Recycling Marks	International	
Battery Perchlorate Warning Information	California	<p>Perchlorate Material - Special handling may apply. See www.dtsc.ca.gov/hazardouswaste/perchlorate</p> <p>This notice is required by California Code of Regulations, Title 22, Division 4.5, and Chapter 33: Best Management Practices for Perchlorate Materials. This product may include a battery which contains Perchlorate material.</p>

Table 10. Product Regulatory Compliance Markings

Regulatory Compliance	Country	Marking
Safety	Multiple Power Cord Marking	 <p>This unit has more than one power supply cord. To reduce the risk of electrical shock, disconnect (2) two power supply cords before servicing.</p> <p>Simplified Chinese:</p> <div data-bbox="902 758 1421 842" style="border: 1px solid black; padding: 2px;"> <p>注意： 本設備包括多條電源系統電纜。為避免遭受電擊，在進行維修之前應斷開兩（2）條電源系統電纜。</p> </div> <p>Traditional Chinese:</p> <div data-bbox="902 961 1421 1045" style="border: 1px solid black; padding: 2px;"> <p>注意： 本設備包括多條電源系統電纜。為避免遭受電擊，在進行維修之前應斷開兩（2）條電源系統電纜。</p> </div> <p>German:</p> <p>Dieses Geräte hat mehr als ein Stromkabel. Um eine Gefahr des elektrischen Schlages zu verringern trennen sie beide (2) Stromkabeln bevor Instandhaltung.</p>
Nordic Countries	Connection to Proper Ground Outlet	<p>"WARNING:"</p> <p>"Apparaten skall anslutas till jordat uttag, när den ansluts till ett nätverk."</p> <p>"Laite on liitettävä suojamaadoituskoskettimilla varustettuun pistorasiaan."</p> <p>"Connect only to a properly earth grounded outlet."</p>
Safety	Stand-by power	

Rack Mount Installation Guidelines

Anchor the equipment rack: The equipment rack must be anchored to an unmovable support to prevent it from falling over when one or more servers are extended in front of the rack on slides. You must also consider the weight of any other device installed in the rack. A crush hazard exists should the rack tilt forward which could cause serious injury.

Temperature: The temperature, in which the server operates when installed in an equipment rack, must not go below 5 °C (41 °F) or rise above 40 °C (104 °F). Extreme fluctuations in temperature can cause a variety of problems in your server.

Ventilation: The equipment rack must provide sufficient airflow to the front of the server to maintain proper cooling. The rack must also include ventilation sufficient to exhaust a maximum of 1023 BTU's (British Thermal Units) per hour for the server. The rack selected and the ventilation provided must be suitable to the environment in which the server will be used.

If AC power supplies are installed:

Mains AC power disconnection: The AC power cord(s) is considered the mains disconnect for the server and must be readily accessible when installed. If the individual server power cord(s) will not be readily accessible for disconnection then you are responsible for installing an AC power disconnect for the entire rack unit. This main disconnect must be readily accessible, and it must be labeled as controlling power to the entire rack, not just to the server(s).

Grounding the rack installation: To avoid the potential for an electrical shock hazard, you must include a third wire safety ground conductor with the rack installation. If the server power cord is plugged into an AC outlet that is part of the rack, then you must provide proper grounding for the rack itself. If the server power cord is plugged into a wall AC outlet, the safety ground conductor in the power cord provides proper grounding only for the server. You must provide additional, proper grounding for the rack and other devices installed in it.

Overcurrent protection: The server is designed for an AC line voltage source with up to 20 amperes of overcurrent protection per cord feed. If the power system for the equipment rack is installed on a branch circuit with more than 20 amperes of protection, you must provide supplemental protection for the server.

If DC power supplies are installed:

Connection with a DC (Direct Current) source should only be performed by trained service personnel. The server with DC input is to be installed in a Restricted Access Location in accordance with articles 110-16, 110-17, and 110-18 of the National Electric Code, ANSI/NFPA 70. The DC source must be electrically isolated by double or reinforced insulation from any hazardous AC source.

Main DC power disconnect: You are responsible for installing a properly rated DC power disconnect for the server system. This mains disconnect must be readily accessible, and it must be labeled as controlling power to the server. The circuit breaker of a centralized DC power system may be used as a disconnect device when easily accessible and should be rated no more than 10 amps.

Grounding the server: To avoid the potential for an electrical shock hazard, you must reliably connect an earth grounding conductor to the server. The earth grounding conductor must be a minimum 18AWG connected to the earth ground stud(s) on the rear of the server. The safety ground conductor should be connected to the chassis stud with a Listed closed two-hole crimp terminal having 5/8 inch pitch. The nuts on the chassis earth ground studs should be installed with a 10 in/lbs torque. The safety ground conductor provides proper grounding only for the server. You must provide additional, proper grounding for the rack and other devices installed in it.

Overcurrent protection: Overcurrent protection circuit breakers must be provided as part of each host equipment rack and must be incorporated in the field wiring between the DC source and the server. The branch circuit protection shall be rated minimum 75Vdc, 10 A maximum per feed pair. If the DC power system for the equipment rack is installed with more than 10 amperes of protection, you must provide supplemental protection for the server.

Power Cord Usage Guidelines

Warning: Do not attempt to modify or use an AC power cord set that is not the exact type required. You must use a power cord set that meets the following criteria:

- *Rating: In the U.S. and Canada, cords must be UL (Underwriters Laboratories, Inc.) Listed/CSA (Canadian Standards Organization) Certified type SJT, 18-3 AWG (American Wire Gauge). Outside of the U.S. and Canada, cords must be flexible harmonized (<HAR>) or VDE (Verband Deutscher Elektrotechniker, German Institute of Electrical Engineers) certified cord with 3 x 0.75 mm conductors rated 250 VAC (Volts Alternating Current).*
- *Connector, wall outlet end: Cords must be terminated in grounding-type male plug designed for use in your region. The connector must have certification marks showing certification by an agency acceptable in your region and for U.S. must be Listed and rated 125% of overall current rating of the server.*
- *Connector, server end: The connectors that plug into the AC receptacle on the server must be an approved IEC (International Electrotechnical Commission) 320, sheet C13, type female connector.*
- *Cord length and flexibility: Cords must be less than 4.5 meters (14.76 feet) long.*

Electromagnetic Compatibility Notices

FCC Verification Statement (USA)

This device complies with Part 15 of the FCC Rules. Operation is subject to the following two conditions: (1) this device may not cause harmful interference, and (2) this device must accept any interference received, including interference that may cause undesired operation.

For questions related to the EMC performance of this product, contact:

Intel Corporation
5200 N.E. Elam Young Parkway
Hillsboro, OR 97124-6497
1-800-628-8686

This equipment has been tested and found to comply with the limits for a Class A digital device, pursuant to Part 15 of the FCC Rules. These limits are designed to provide reasonable protection against harmful interference in a residential installation. This equipment generates, uses, and can radiate radio frequency energy and, if not installed and used in accordance with the instructions, may cause harmful interference to radio communications. However, there is no guarantee that interference will not occur in a particular installation. If this equipment does cause harmful interference to radio or television reception, which can be determined by turning the equipment off and on, the user is encouraged to try to correct the interference by one or more of the following measures:

- Reorient or relocate the receiving antenna.
- Increase the separation between the equipment and the receiver.
- Connect the equipment to an outlet on a circuit other than the one to which the receiver is connected.
- Consult the dealer or an experienced radio/TV technician for help.

Any changes or modifications not expressly approved by the grantee of this device could void the user's authority to operate the equipment. The customer is responsible for ensuring compliance of the modified product.

Only peripherals (computer input/output devices, terminals, printers, etc.) that comply with FCC Class A or B limits may be attached to this computer product. Operation with noncompliant peripherals is likely to result in interference to radio and TV reception.

All cables used to connect to peripherals must be shielded and grounded. Operation with cables, connected to peripherals that are not shielded and grounded may result in interference to radio and TV reception.

ICES-003 (Canada)

Cet appareil numérique respecte les limites bruits radioélectriques applicables aux appareils numériques de Classe A prescrites dans la norme sur le matériel brouilleur: "Appareils Numériques", NMB-003 édictée par le Ministre Canadien des Communications.

English translation of the notice above:

This digital apparatus does not exceed the Class A limits for radio noise emissions from digital apparatus set out in the interference-causing equipment standard entitled: "Digital Apparatus," ICES-003 of the Canadian Department of Communications.

CE Declaration of Conformity (Europe)

This product has been tested in accordance to, and complies with the Low Voltage Directive (73/23/EEC) and EMC Directive (89/336/EEC). The product has been marked with the CE Mark to illustrate its compliance.

VCCI (Japan)

この装置は、情報処理装置等電波障害自主規制協議会（VCCI）の基準に基づくクラスA情報技術装置です。この装置を家庭環境で使用すると電波妨害を引き起こすことがあります。この場合には使用者が適切な対策を講ずるよう要求されることがあります。

English translation of the preceding notice:

This is a Class A product based on the standard of the Voluntary Control Council for Interference (VCCI) from Information Technology Equipment. If this is used near a radio or television receiver in a domestic environment, it may cause radio interference. Install and use the equipment according to the instruction manual.

BSMI (Taiwan)

警告使用者：
這是甲類的資訊產品，在居住的環境中使用時，可能會造成射頻干擾，在這種情況下，使用者會被要求採取某些適當的對策

The BSMI Certification Marking and EMC warning is located on the outside rear area of the product.

KCC (Korea)

Following is the KCC certification information for Korea.



1. 기기의 명칭(모델명) :
2. 인증번호 :
3. 인증받은 자의 상호 :
4. 제조년월일 :
5. 제조자/제조국가 :

English translation of the notice above:

1. Type of Equipment (Model Name): On License and Product
2. Certification No.: On RRL certificate. Obtain certificate from local Intel representative
3. Name of Certification Recipient: Intel Corporation
4. Date of Manufacturer: Refer to date code on product
5. Manufacturer/Nation: Intel Corporation/Refer to country of origin marked on product

Regulated Specified Components

To maintain the UL listing and compliance to other regulatory certifications and/or declarations, the following regulated components must be used and conditions adhered to. Interchanging or use of other components will void the UL listing and other product certifications and approvals.



Updated product information for configurations can be found on the Intel Server Builder Web site at the following URL: <http://channel.intel.com/go/serverbuilder>

If you do not have access to Intel's Web address, please contact your local Intel representative.

- **Server Chassis:** (base chassis is provided with power supply and fans) - UL listed.
- **Server board:** you must use an Intel server board - UL recognized.
- **Add-in boards:** must have a printed wiring board flammability rating of minimum UL94V-1. Add-in boards containing external power connectors and/or lithium batteries must be UL recognized or UL listed. Any add-in board containing modem telecommunication circuitry must be UL listed. In addition, the modem must have the appropriate telecommunications, safety, and EMC approvals for the region in which it is sold.
- **Peripheral Storage Devices:** must be UL recognized or UL listed accessory and TUV or VDE Certificationd. Maximum power rating of any one device is 19 watts. Total server configuration is not to exceed the maximum loading conditions of the power supply.

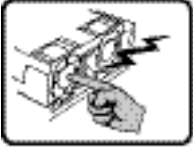
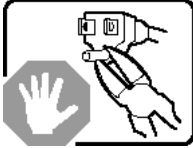
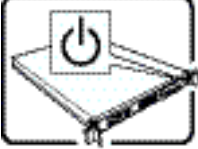

Appendix F: Installation/Assembly Safety Instructions

English

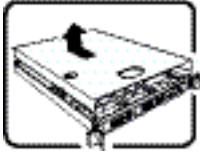
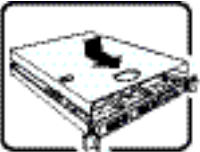
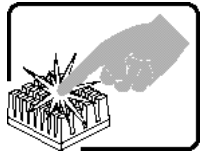
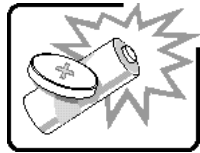
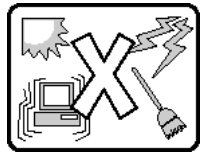
	<p>The power supply in this product contains no user-serviceable parts. There may be more than one supply in this product. Refer servicing only to qualified personnel.</p>
	<p>Do not attempt to modify or use the supplied AC power cord if it is not the exact type required. A product with more than one power supply will have a separate AC power cord for each supply.</p>
	<p>The power button on the system does not turn off system AC power. To remove AC power from the system, you must unplug each AC power cord from the wall outlet or power supply.</p> <p>The power cord(s) is considered the disconnect device to the main (AC) power. The socket outlet that the system plugs into shall be installed near the equipment and shall be easily accessible.</p>
	<p>SAFETY STEPS: Whenever you remove the chassis covers to access the inside of the system, follow these steps:</p> <ol style="list-style-type: none">1. Turn off all peripheral devices connected to the system.2. Turn off the system by pressing the power button.3. Unplug all AC power cords from the system or from wall outlets.4. Label and disconnect all cables connected to I/O connectors or ports on the back of the system.5. Provide some electrostatic discharge (ESD) protection by wearing an antistatic wrist strap attached to chassis ground of the system-any unpainted metal surface-when handling components.6. Do not operate the system with the chassis covers removed.

	<p>After you have completed the six SAFETY steps above, you can remove the system covers. To do this:</p> <ol style="list-style-type: none"> 1. Unlock and remove the padlock from the back of the system if a padlock has been installed. 2. Remove and save all screws from the covers. 3. Remove the cover(s).
	<p>For proper cooling and airflow, always reinstall the chassis covers before turning on the system. Operating the system without the covers in place can damage system parts. To install the covers:</p> <ol style="list-style-type: none"> 1. Check first to make sure you have not left loose tools or parts inside the system. 2. Check that cables, add-in boards, and other components are properly installed. 3. Attach the covers to the chassis with the screws removed earlier, and tighten them firmly. 4. Insert and lock the padlock to the system to prevent unauthorized access inside the system. 5. Connect all external cables and the AC power cord(s) to the system.
	<p>A microprocessor and heat sink may be hot if the system has been running. Also, there may be sharp pins and edges on some board and chassis parts. Contact should be made with care. Consider wearing protective gloves.</p>
	<p>Danger of explosion if the battery is incorrectly replaced. Replace only with the same or equivalent type recommended by the equipment manufacturer. Dispose of used batteries according to manufacturer's instructions.</p>
	<p>The system is designed to operate in a typical office environment. Choose a site that is:</p> <ul style="list-style-type: none"> • Clean and free of airborne particles (other than normal room dust). • Well ventilated and away from sources of heat including direct sunlight. • Away from sources of vibration or physical shock. • Isolated from strong electromagnetic fields produced by electrical devices. • In regions that are susceptible to electrical storms, we recommend you plug your system into a surge suppresser and disconnect telecommunication lines to your modem during an electrical storm. • Provided with a properly grounded wall outlet. • Provided with sufficient space to access the power supply cord(s), because they serve as the product's main power disconnect.

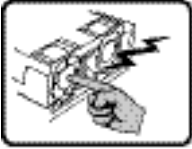
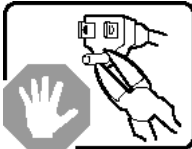
Deutsch

	<p>Benutzer können am Netzgerät dieses Produkts keine Reparaturen vornehmen. Das Produkt enthält möglicherweise mehrere Netzgeräte. Wartungsarbeiten müssen von qualifizierten Technikern ausgeführt werden.</p>
	<p>Versuchen Sie nicht, das mitgelieferte Netzkabel zu ändern oder zu verwenden, wenn es sich nicht genau um den erforderlichen Typ handelt. Ein Produkt mit mehreren Netzgeräten hat für jedes Netzgerät ein eigenes Netzkabel.</p>
	<p>Der Wechselstrom des Systems wird durch den Ein-/Aus-Schalter für Gleichstrom nicht ausgeschaltet. Ziehen Sie jedes Wechselstrom-Netzkabel aus der Steckdose bzw. dem Netzgerät, um den Stromanschluß des Systems zu unterbrechen.</p> <p>Die Stromkabel sind das "Unterbrechungsgerät" zur Hauptstromquelle. Die Steckdose, in die das System gesteckt wird, sollte sich in der Nähe des Gerätes befinden und leicht zugänglich sein.</p>
	<p>SICHERHEITSMASSNAHMEN: Immer wenn Sie die Gehäuseabdeckung abnehmen um an das Systeminnere zu gelangen, sollten Sie folgende Schritte beachten:</p> <ol style="list-style-type: none">1. Schalten Sie alle an Ihr System angeschlossenen Peripheriegeräte aus.2. Schalten Sie das System mit dem Hauptschalter aus.3. Ziehen Sie den Stromanschlußstecker Ihres Systems aus der Steckdose.4. Auf der Rückseite des Systems beschriften und ziehen Sie alle Anschlußkabel von den I/O Anschlüssen oder Ports ab.5. Tragen Sie ein geerdetes Antistatik Gelenkband, um elektrostatische Ladungen (ESD) über blanke Metallstellen bei der Handhabung der Komponenten zu vermeiden.6. Schalten Sie das System niemals ohne ordnungsgemäß montiertes Gehäuse ein.

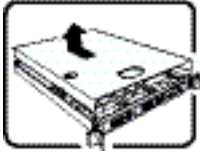
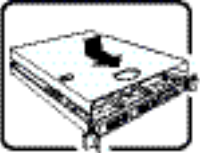
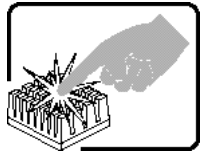
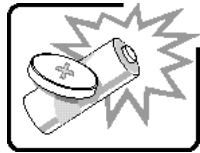
	<p>SICHERHEITSMASSNAHMEN: Immer wenn Sie die Gehäuseabdeckung abnehmen um an das Systeminnere zu gelangen, sollten Sie folgende Schritte beachten:</p> <ol style="list-style-type: none"> 1. Schalten Sie alle an Ihr System angeschlossenen Peripheriegeräte aus. 2. Schalten Sie das System mit dem Hauptschalter aus. 3. Ziehen Sie den Stromanschlußstecker Ihres Systems aus der Steckdose. 4. Auf der Rückseite des Systems beschrifteten und ziehen Sie alle Anschlußkabel von den I/O Anschlüssen oder Ports ab. 5. Tragen Sie ein geerdetes Antistatik Gelenkband, um elektrostatische Ladungen (ESD) über blanke Metallstellen bei der Handhabung der Komponenten zu vermeiden. 6. Schalten Sie das System niemals ohne ordnungsgemäß montiertes Gehäuse ein.
	<p>Zur ordnungsgemäßen Kühlung und Lüftung muß die Gehäuseabdeckung immer wieder vor dem Einschalten installiert werden. Ein Betrieb des Systems ohne angebrachte Abdeckung kann Ihrem System oder Teile darin beschädigen. Um die Abdeckung wieder anzubringen:</p> <ol style="list-style-type: none"> 1. Vergewissern Sie sich, daß Sie keine Werkzeuge oder Teile im Innern des Systems zurückgelassen haben. 2. Überprüfen Sie alle Kabel, Zusatzkarten und andere Komponenten auf ordnungsgemäßen Sitz und Installation. 3. Bringen Sie die Abdeckungen wieder am Gehäuse an, indem Sie die zuvor gelösten Schrauben wieder anbringen. Ziehen Sie diese gut an. 4. Bringen Sie die Verschlusseinrichtung (Padlock) wieder an und schließen Sie diese, um ein unerlaubtes Öffnen des Systems zu verhindern. 5. Schließen Sie alle externen Kabel und den AC Stromanschlußstecker Ihres Systems wieder an.
	<p>Der Mikroprozessor und der Kühler sind möglicherweise erhitzt, wenn das System in Betrieb ist. Außerdem können einige Platinen und Gehäuseteile scharfe Spitzen und Kanten aufweisen. Arbeiten an Platinen und Gehäuse sollten vorsichtig ausgeführt werden. Sie sollten Schutzhandschuhe tragen.</p>
	<p>Bei falschem Einsetzen einer neuen Batterie besteht Explosionsgefahr. Die Batterie darf nur durch denselben oder einen entsprechenden, vom Hersteller empfohlenen Batterietyp ersetzt werden. Entsorgen Sie verbrauchte Batterien den Anweisungen des Herstellers entsprechend.</p>

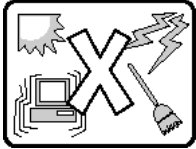
	<p>Das System wurde für den Betrieb in einer normalen Büroumgebung entwickelt. Der Standort sollte:</p> <ul style="list-style-type: none"> • "sauber und staubfrei sein (Hausstaub ausgenommen); • "gut gelüftet und keinen Heizquellen ausgesetzt sein (einschließlich direkter Sonneneinstrahlung); • "keinen Erschütterungen ausgesetzt sein; • "keine starken, von elektrischen Geräten erzeugten elektromagnetischen Felder aufweisen; • "in Regionen, in denen elektrische Stürme auftreten, mit einem Überspannungsschutzgerät verbunden sein; während eines elektrischen Sturms sollte keine Verbindung der Telekommunikationsleitungen mit dem Modem bestehen; • "mit einer geerdeten Wechselstromsteckdose ausgerüstet sein; • "über ausreichend Platz verfügen, um Zugang zu den Netzkabeln zu gewährleisten, da der Stromanschluß des Produkts hauptsächlich über die Kabel unterbrochen wird
---	--

Français

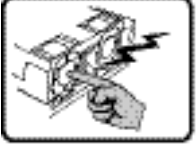
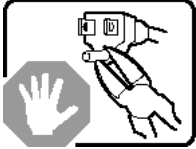
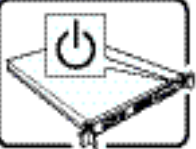

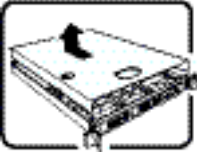
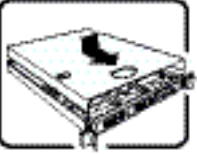
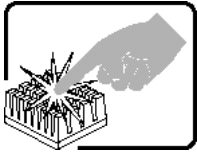

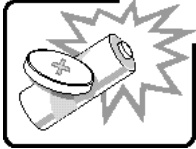
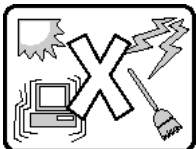
	<p>Le bloc d'alimentation de ce produit ne contient aucune pièce pouvant être réparée par l'utilisateur. Ce produit peut contenir plus d'un bloc d'alimentation. Veuillez contacter un technicien qualifié en cas de problème.</p>
	<p>Ne pas essayer d'utiliser ni modifier le câble d'alimentation CA fourni, s'il ne correspond pas exactement au type requis. Le nombre de câbles d'alimentation CA fournis correspond au nombre de blocs d'alimentation du produit</p>
	<p>Notez que le commutateur CC de mise sous tension /hors tension du panneau avant n'éteint pas l'alimentation CA du système. Pour mettre le système hors tension, vous devez débrancher chaque câble d'alimentation de sa prise.</p> <p>C'est le câble d'alimentation qui est considéré comme le moyen de se déconnecter du CA. La prise à laquelle le système est branché doit se situer à proximité de l'équipement et être facilement accessible.</p>

	<p>CONSIGNES DE SÉCURITÉ -Lorsque vous ouvrez le boîtier pour accéder à l'intérieur du système, suivez les consignes suivantes:</p> <ol style="list-style-type: none"> 1. Mettez hors tension tous les périphériques connectés au système. 2. Mettez le système hors tension en mettant l'interrupteur général en position OFF (bouton-poussoir). 3. Débranchez tous les cordons d'alimentation c.a. du système et des prises murales. 4. Identifiez et débranchez tous les câbles reliés aux connecteurs d'E-S ou aux accès derrière le système. 5. Pour prévenir les décharges électrostatiques lorsque vous touchez aux composants, portez une bande antistatique pour poignet et reliez-la à la masse du système (toute surface métallique non peinte du boîtier). 6. Ne faites pas fonctionner le système tandis que le boîtier est ouvert.
	<p>Une fois TOUTES les étapes précédentes accomplies, vous pouvez retirer les panneaux du système. Procédez comme suit:</p> <ol style="list-style-type: none"> 1. Si un cadenas a été installé sur à l'arrière du système, déverrouillez-le et retirez-le. 2. Retirez toutes les vis des panneaux et mettez-les dans un endroit sûr. 3. Retirez les panneaux.
	<p>Afin de permettre le refroidissement et l'aération du système, réinstallez toujours les panneaux du boîtier avant de mettre le système sous tension. Le fonctionnement du système en l'absence des panneaux risque d'endommager ses pièces. Pour installer les panneaux, procédez comme suit:</p> <ol style="list-style-type: none"> 1. Assurez-vous de ne pas avoir oublié d'outils ou de pièces démontées dans le système. 2. Assurez-vous que les câbles, les cartes d'extension et les autres composants sont bien installés. 3. Revissez solidement les panneaux du boîtier avec les vis retirées plus tôt. 4. Remettez le cadenas en place et verrouillez-le afin de prévenir tout accès non autorisé à l'intérieur du système. 5. Rebranchez tous les cordons d'alimentation c. a. et câbles externes au système.
	<p>Le microprocesseur et le dissipateur de chaleur peuvent être chauds si le système a été sous tension. Faites également attention aux broches aiguës des cartes et aux bords tranchants du capot. Nous vous recommandons l'usage de gants de protection.</p>

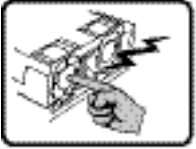
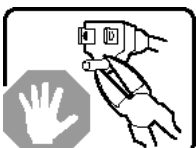
	<p>Danger d'explosion si la batterie n'est pas remontée correctement. Remplacer uniquement avec une batterie du même type ou d'un type équivalent recommandé par le fabricant. Disposez des piles usées selon les instructions du fabricant.</p>
	<p>Le système a été conçu pour fonctionner dans un cadre de travail normal. L'emplacement choisi doit être:</p> <ul style="list-style-type: none"> • "Propre et dépourvu de poussière en suspension (sauf la poussière normale). • "Bien aéré et loin des sources de chaleur, y compris du soleil direct. • "A l'abri des chocs et des sources de vibrations. • "Isolé de forts champs électromagnétiques générés par des appareils électriques. • "Dans les régions sujettes aux orages magnétiques il est recommandé de brancher votre système à un supresseur de surtension, et de débrancher toutes les lignes de télécommunications de votre modem durant un orage. • "Muni d'une prise murale correctement mise à la terre. • "Suffisamment spacieux pour vous permettre d'accéder aux câbles d'alimentation (ceux-ci étant le seul moyen de mettre le système hors tension).

Español

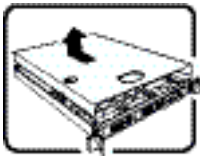
	<p>El usuario debe abstenerse de manipular los componentes de la fuente de alimentación de este producto, cuya reparación debe dejarse exclusivamente en manos de personal técnico especializado. Puede que este producto disponga de más de una fuente de alimentación</p>
	<p>No intente modificar ni usar el cable de alimentación de corriente alterna, si no corresponde exactamente con el tipo requerido. El número de cables suministrados se corresponden con el número de fuentes de alimentación de corriente alterna que tenga el producto</p>

	<p>Nótese que el interruptor activado/desactivado en el panel frontal no desconecta la corriente alterna del sistema. Para desconectarla, deberá desenchufar todos los cables de corriente alterna de la pared o desconectar la fuente de alimentación.</p> <p>Estos cables actúan como dispositivo de desconexión. La toma de corriente deberá estar situada cerca del equipo y ser de fácil acceso.</p>
	<p>INSTRUCCIONES DE SEGURIDAD: Cuando extraiga la tapa del chasis para acceder al interior del sistema, siga las siguientes instrucciones:</p> <ol style="list-style-type: none"> 1. Apague todos los dispositivos periféricos conectados al sistema. 2. Apague el sistema presionando el interruptor encendido/apagado. 3. Desconecte todos los cables de alimentación CA del sistema o de las tomas de corriente alterna. 4. Identifique y desconecte todos los cables enchufados a los conectores E/S o a los puertos situados en la parte posterior del sistema. 5. Cuando manipule los componentes, es importante protegerse contra la descarga electrostática (ESD). Puede hacerlo si utiliza una muñequera antiestática sujeta a la toma de tierra del chasis - o a cualquier tipo de superficie de metal sin pintar. 6. No ponga en marcha el sistema si se han extraído las tapas del chasis.
	<p>Después de completar las seis instrucciones de SEGURIDAD mencionadas, ya puede extraer las tapas del sistema. Para ello:</p> <ol style="list-style-type: none"> 1. Desbloquee y extraiga el bloqueo de seguridad de la parte posterior del sistema, si se ha instalado uno. 2. Extraiga y guarde todos los tornillos de las tapas. Extraiga las tapas.
	<p>Para obtener un enfriamiento y un flujo de aire adecuados, reinstale siempre las tapas del chasis antes de poner en marcha el sistema. Si pone en funcionamiento el sistema sin las tapas bien colocadas puede dañar los componentes del sistema. Para instalar las tapas:</p> <ol style="list-style-type: none"> 1. Asegúrese primero de no haber dejado herramientas o componentes sueltos dentro del sistema. 2. Compruebe que los cables, las placas adicionales y otros componentes se hayan instalado correctamente. 3. Incorpore las tapas al chasis mediante los tornillos extraídos anteriormente, tensándolos firmemente. 4. Inserte el bloqueo de seguridad en el sistema y bloquéelo para impedir que pueda accederse al mismo sin autorización. 5. Conecte todos los cables externos y los cables de alimentación CA al sistema.

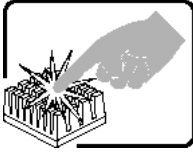
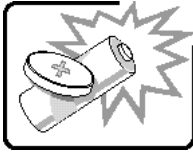
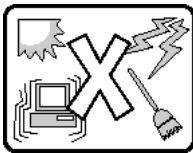
	<p>Si el sistema ha estado en funcionamiento, el microprocesador y el disipador de calor pueden estar aún calientes. También conviene tener en cuenta que en el chasis o en el tablero puede haber piezas cortantes o punzantes. Por ello, se recomienda precaución y el uso de guantes protectores.</p>
	<p>Existe peligro de explosión si la pila no se cambia de forma adecuada. Utilice solamente pilas iguales o del mismo tipo que las recomendadas por el fabricante del equipo. Para deshacerse de las pilas usadas, siga igualmente las instrucciones del fabricante.</p>
	<p>El sistema está diseñado para funcionar en un entorno de trabajo normal. Escoja un lugar:</p> <ul style="list-style-type: none"> • "Limpio y libre de partículas en suspensión (salvo el polvo normal). • "Bien ventilado y alejado de fuentes de calor, incluida la luz solar directa. • "Alejado de fuentes de vibración. • "Aislado de campos electromagnéticos fuertes producidos por dispositivos eléctricos. • "En regiones con frecuentes tormentas eléctricas, se recomienda conectar su sistema a un eliminador de sobrevoltage y desconectar el módem de las líneas de telecomunicación durante las tormentas. • "Provisto de una toma de tierra correctamente instalada. • "Provisto de espacio suficiente como para acceder a los cables de alimentación, ya que éstos hacen de medio principal de desconexión del sistema.

Italiano

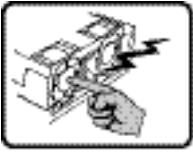
	<p>Rivolgersi ad un tecnico specializzato per la riparazione dei componenti dell'alimentazione di questo prodotto. È possibile che il prodotto disponga di più fonti di alimentazione.</p>
---	--

	<p>Non modificare o utilizzare il cavo di alimentazione in c.a. fornito dal produttore, se non corrisponde esattamente al tipo richiesto. Ad ogni fonte di alimentazione corrisponde un cavo di alimentazione in c.a. separato</p>
	<p>L'interruttore attivato/disattivato nel pannello anteriore non interrompe l'alimentazione in c.a. del sistema. Per interromperla, è necessario scollegare tutti i cavi di alimentazione in c.a. dalle prese a muro o dall'alimentazione di corrente.</p> <p>Il cavo è considerato il dispositivo d'interruzione dell'alimentazione principale (in c.a.). La presa alla quale si collega il sistema deve essere installata vicino all'unità e deve essere facilmente accessibile.</p>
	<p>PASSI DI SICUREZZA: Qualora si rimuovano le coperture del telaio per accedere all'interno del sistema, seguire i seguenti passi:</p> <ol style="list-style-type: none"> 1. Spegnere tutti i dispositivi periferici collegati al sistema. 2. Spegnere il sistema, usando il pulsante spento/acceso dell'interruttore del sistema. 3. Togliere tutte le spine dei cavi del sistema dalle prese elettriche. 4. Identificare e sconnettere tutti i cavi attaccati ai collegamenti I/O od alle prese installate sul retro del sistema. 5. Qualora si tocchino i componenti, proteggersi dallo scarico elettrostatico (SES), portando un cinghia anti-statica da polso che è attaccata alla presa a terra del telaio del sistema - qualsiasi superficie non dipinta - . 6. Non far operare il sistema quando il telaio è senza le coperture.
	<p>Dopo aver seguito i sei passi di SICUREZZA sopracitati, togliere le coperture del telaio del sistema come segue:</p> <ol style="list-style-type: none"> 1. Aprire e rimuovere il lucchetto dal retro del sistema qualora ve ne fosse uno installato. 2. Togliere e mettere in un posto sicuro tutte le viti delle coperture. 3. Togliere le coperture.
	<p>Per il giusto flusso dell'aria e raffreddamento del sistema, rimettere sempre le coperture del telaio prima di riaccendere il sistema. Operare il sistema senza le coperture al loro proprio posto potrebbe danneggiare i componenti del sistema. Per rimettere le coperture del telaio:</p> <ol style="list-style-type: none"> 1. Controllare prima che non si siano lasciati degli attrezzi o dei componenti dentro il sistema. 2. Controllare che i cavi, dei supporti aggiuntivi ed altri componenti siano stati installati appropriatamente. 3. Attaccare le coperture al telaio con le viti tolte in precedenza e avvitarle strettamente. 4. Inserire e chiudere a chiave il lucchetto sul retro del sistema per impedire l'accesso non autorizzato al sistema. 5. Ricollegare tutti i cavi esterni e le prolunghe AC del sistema.

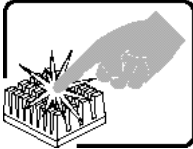
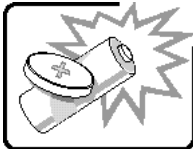
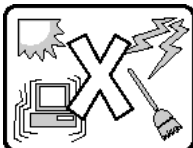
	<p>Se il sistema è stato a lungo in funzione, il microprocessore e il dissipatore di calore potrebbero essere surriscaldati. Fare attenzione alla presenza di piedini appuntiti e parti taglienti sulle schede e sul telaio. È consigliabile l'uso di guanti di protezione.</p>
	<p>Esiste il pericolo di un'esplosione se la pila non viene sostituita in modo corretto. Utilizzare solo pile uguali o di tipo equivalente a quelle consigliate dal produttore. Per disfarsi delle pile usate, seguire le istruzioni del produttore.</p>
	<p>Il sistema è progettato per funzionare in un ambiente di lavoro tipo. Scegliere una postazione che sia:</p> <ul style="list-style-type: none"> • "Pulita e libera da particelle in sospensione (a parte la normale polvere presente nell'ambiente). • "Ben ventilata e lontana da fonti di calore, compresa la luce solare diretta. • "Al riparo da urti e lontana da fonti di vibrazione. • "Isolata dai forti campi magnetici prodotti da dispositivi elettrici. • "In aree soggette a temporali, è consigliabile collegare il sistema ad un limitatore di corrente. In caso di temporali, scollegare le linee di comunicazione dal modem. • "Dotata di una presa a muro correttamente installata. • "Dotata di spazio sufficiente ad accedere ai cavi di alimentazione, i quali rappresentano il mezzo principale di scollegamento del sistema.

Appendix G: Safety Information

English

Server Safety Information

This document applies to Intel® server boards, Intel® server chassis (pedestal and rack-mount) and installed peripherals. To reduce the risk of bodily injury, electrical shock, fire, and equipment damage, read this document and observe all warnings and precautions in this guide before installing or maintaining your Intel® server product.



In the event of a conflict between the information in this document and information provided with the product or on the website for a particular product, the product documentation takes precedence.



Your server should be integrated and serviced only by technically qualified persons.

You must adhere to the guidelines in this guide and the assembly instructions in your server manuals to ensure and maintain compliance with existing product certifications and approvals. Use only the described, regulated components specified in this guide. Use of other products/components will void the UL Listing and other regulatory approvals of the product, and may result in noncompliance with product regulations in the region(s) in which the product is sold.

Safety Warnings and Cautions

To avoid personal injury or property damage, before you begin installing the product, read, observe, and adhere to all of the following safety instructions and information. The following safety symbols may be used throughout the documentation and may be marked on the product and/or the product packaging.

CAUTION	Indicates the presence of a hazard that may cause minor personal injury or property damage if the CAUTION is ignored.
WARNING	Indicates the presence of a hazard that may result in serious personal injury if the WARNING is ignored.
	Indicates potential hazard if indicated information is ignored.
	Indicates shock hazards that result in serious injury or death if safety instructions are not followed.
	Indicates hot components or surfaces.

	Indicates do not touch fan blades, may result in injury.
	Indicates to unplug all AC power cord(s) to disconnect AC power
	Please recycle battery

Intended Application Uses

This product was evaluated as Information Technology Equipment (ITE), which may be installed in offices, schools, computer rooms, and similar commercial type locations. The suitability of this product for other product categories and environments (such as medical, industrial, residential, alarm systems, and test equipment), other than an ITE application, may require further evaluation.

Site Selection

The system is designed to operate in a typical office environment. Choose a site that is:

- Clean, dry, and free of airborne particles (other than normal room dust).
- Well-ventilated and away from sources of heat including direct sunlight and radiators.
- Away from sources of vibration or physical shock.
- Isolated from strong electromagnetic fields produced by electrical devices.
- In regions that are susceptible to electrical storms, we recommend you plug your system into a surge suppresser and disconnect telecommunication lines to your modem during an electrical storm.
- Provided with a properly grounded wall outlet.
- Provided with sufficient space to access the power supply cord(s), because they serve as the product's main power disconnect.

Equipment Handling Practices

Reduce the risk of personal injury or equipment damage:

- Conform to local occupational health and safety requirements when moving and lifting equipment.
- Use mechanical assistance or other suitable assistance when moving and lifting equipment.
- To reduce the weight for easier handling, remove any easily detachable components.

Power and Electrical Warnings

Caution: *The power button, indicated by the stand-by power marking, DOES NOT completely turn off the system AC power; 5V standby power is active whenever the system is plugged in. To remove power from system, you must unplug the AC power cord from the wall outlet. Your system may use more than one AC power cord. Make sure all AC power cords are unplugged. Make sure the AC power cord(s) is/are unplugged before you open the chassis, or add or remove any non hot-plug components.*

Do not attempt to modify or use an AC power cord if it is not the exact type required. A separate AC cord is required for each system power supply.

Some power supplies in Intel[®] servers use Neutral Pole Fusing. To avoid risk of shock use caution when working with power supplies that use Neutral Pole Fusing.

The power supply in this product contains no user-serviceable parts. Do not open the power supply. Hazardous voltage, current and energy levels are present inside the power supply. Return to manufacturer for servicing.

When replacing a hot-plug power supply, unplug the power cord to the power supply being replaced before removing it from the server.

To avoid risk of electric shock, turn off the server and disconnect the power cord, telecommunications systems, networks, and modems attached to the server before opening it.

Power Cord Warnings

If an AC power cord was not provided with your product, purchase one that is approved for use in your country.

Caution: *To avoid electrical shock or fire, check the power cord(s) that will be used with the product as follows:*

- *Do not attempt to modify or use the AC power cord(s) if they are not the exact type required to fit into the grounded electrical outlets*
- *The power cord(s) must meet the following criteria:*
- *The power cord must have an electrical rating that is greater than that of the electrical current rating marked on the product.*
- *The power cord must have safety ground pin or contact that is suitable for the electrical outlet.*
- *The power supply cord(s) is/are the main disconnect device to AC power. The socket outlet(s) must be near the equipment and readily accessible for disconnection.*
- *The power supply cord(s) must be plugged into socket-outlet(s) that is /are provided with a suitable earth ground.*

System Access Warnings

Caution: To avoid personal injury or property damage, the following safety instructions apply whenever accessing the inside of the product:

- Turn off all peripheral devices connected to this product.
- Turn off the system by pressing the power button to off.
- Disconnect the AC power by unplugging all AC power cords from the system or wall outlet.
- Disconnect all cables and telecommunication lines that are connected to the system.
- Retain all screws or other fasteners when removing access cover(s). Upon completion of accessing inside the product, refasten access cover with original screws or fasteners.
- Do not access the inside of the power supply. There are no serviceable parts in the power supply. Return to manufacturer for servicing.
- Power down the server and disconnect all power cords before adding or replacing any non hot-plug component.
- When replacing a hot-plug power supply, unplug the power cord to the power supply being replaced before removing the power supply from the server.

Caution: If the server has been running, any installed processor(s) and heat sink(s) may be hot. Unless you are adding or removing a hot-plug component, allow the system to cool before opening the covers. To avoid the possibility of coming into contact with hot component(s) during a hot-plug installation, be careful when removing or installing the hot-plug component(s).

Caution: To avoid injury do not contact moving fan blades. If your system is supplied with a guard over the fan, do not operate the system without the fan guard in place.

Rack Mount Warnings

The equipment rack must be anchored to an unmovable support to prevent it from tipping when a server or piece of equipment is extended from it. The equipment rack must be installed according to the rack manufacturer's instructions.

Install equipment in the rack from the bottom up, with the heaviest equipment at the bottom of the rack.

Extend only one piece of equipment from the rack at a time.

You are responsible for installing a main power disconnect for the entire rack unit. This main disconnect must be readily accessible, and it must be labeled as controlling power to the entire unit, not just to the server(s).

To avoid risk of potential electric shock, a proper safety ground must be implemented for the rack and each piece of equipment installed in it.

Electrostatic Discharge (ESD)

Caution: ESD can damage disk drives, boards, and other parts. We recommend that you perform all procedures at an ESD workstation. If one is not available, provide some ESD protection by wearing an antistatic wrist strap attached to chassis ground -- any unpainted metal surface -- on your server when handling parts.

Always handle boards carefully. They can be extremely sensitive to ESD. Hold boards only by their edges. After removing a board from its protective wrapper or from the server, place the board component side up on a grounded, static free surface. Use a conductive foam pad if available but not the board wrapper. Do not slide board over any surface.

Other Hazards

Battery Replacement

Caution: There is the danger of explosion if the battery is incorrectly replaced. When replacing the battery, use only the battery recommended by the equipment manufacturer.

Dispose of batteries according to local ordinances and regulations.

Do not attempt to recharge a battery.

Do not attempt to disassemble, puncture, or otherwise damage a battery.

Cooling and Airflow

Caution: Carefully route cables as directed to minimize airflow blockage and cooling problems.

For proper cooling and airflow, operate the system only with the chassis covers installed. Operating the system without the covers in place can damage system parts. To install the covers:

- *Check first to make sure you have not left loose tools or parts inside the system.*
- *Check that cables, add-in boards, and other components are properly installed.*
- *Attach the covers to the chassis according to the product instructions.*

Laser Peripherals or Devices

Caution: To avoid risk of radiation exposure and/or personal injury:

- *Do not open the enclosure of any laser peripheral or device*
- *Laser peripherals or devices have are not user serviceable*
- *Return to manufacturer for servicing*

Deutsch

Sicherheitshinweise für den Server

Das vorliegende Dokument bezieht sich auf Intel® Serverplatinen, Intel® Servergehäuse (Standfuß und Rack) sowie installierte Peripheriegeräte. Es enthält Warnungen und Vorsichtsmaßnahmen zur Vermeidung von Gefahren durch Verletzung, Stromschlag, Feuer und Beschädigungen von Geräten. Lesen Sie diese Dokument daher sorgfältig, bevor Sie Ihr Intel® Serverprodukt installieren oder warten.



Bei Widersprüchen zwischen den hier vorliegenden Angaben und den Informationen im Lieferumfang des Produkts oder auf der Website des betreffenden Produkts hat die Produktdokumentation Vorrang.



Die Integration und Wartung des Servers darf nur durch technisch qualifizierte Personen erfolgen.

Um die Einhaltung der vorhandenen Zulassungen und Genehmigungen für das Produkt zu gewährleisten, sind die Richtlinien in diesem Handbuch sowie die Montageanleitungen in den Serverhandbüchern zu beachten. Verwenden Sie nur die beschriebenen, zugelassenen Komponenten, die im vorliegenden Handbuch angegeben werden. Die Verwendung anderer Produkte oder Komponenten führt zum Erlöschen der UL-Zulassung und anderer Genehmigungen für das Produkt. Dadurch kann das Produkt gegen Produktbestimmungen verstoßen, die im Verkaufsland gelten.

Sicherheitshinweise und Vorsichtsmaßnahmen

Um Verletzungen und Beschädigungen zu vermeiden, sollten Sie vor dem Beginn der Produktinstallation die nachfolgend aufgeführten Sicherheitshinweise und -informationen sorgfältig lesen und befolgen. In dem vorliegenden Handbuch sowie auf dem Produkt und auf der Verpackung werden folgende Sicherheitssymbole verwendet:

VORSICHT	Weist auf eine Gefahrenquelle hin, die bei Nichtbeachtung des VORSICHTSHINWEISES zu leichteren Verletzungen bzw. Sachbeschädigungen führen kann.
WARNUNG	Weist auf eine Gefahrenquelle hin, die bei Nichtbeachtung der WARNUNG zu ernstesten Verletzungen führen kann.
	Weist auf potentielle Gefahr bei Nichtbeachtung der angezeigten Informationen hin.
	Weist auf die Gefahr eines Stromschlags hin, der bei Nichtbeachtung der Sicherheitshinweise zu schweren oder tödlichen Verletzungen führen kann.
	Weist auf Verbrennungsgefahr an heißen Bauteilen bzw. Oberflächen hin.

	Weist darauf hin, daß das Anfassen des Gebläses zu Verletzungen führen kann.
	Bedeutet, alle Netzkabel abzuziehen und das Gerät von der Netzspannung zu trennen.
	Bereiten Sie bitte Batterie auf

Zielbenutzer der Anwendung

Dieses Produkt wurde in seiner Eigenschaft als IT-Gerät getestet, das in Büros, Schulen, Computerräumen und ähnlichen öffentlichen Räumlichkeiten installiert werden kann. Die Eignung dieses Produkts für andere Einsatzbereiche als IT (z. B. Medizin, Industrie, Alarmsysteme oder Prüfgeräte) kann u. U. weitere Tests erfordern.

Standortauswahl

Das System ist für den Betrieb innerhalb normaler Büroumgebungen geeignet. Wählen Sie einen Standort, der folgenden Kriterien entspricht:

- Sauber, trocken und frei von Partikeln in der Luft (außer dem normalen Raumstaub).
- Gut belüftet, nicht in der Nähe von Wärmequellen und keiner direkten Sonnenbestrahlung ausgesetzt.
- Nicht in der Nähe von Vibrations- oder Erschütterungsquellen.
- Abgeschirmt von starken elektromagnetischen Feldern, die durch elektrische Geräte erzeugt werden.
- In gewittergefährdeten Gebieten sollten Sie das System an einen Überspannungsschutz anschließen und bei einem Gewitter die Telekommunikationskabel zum Modem abziehen.
- Eine ordnungsgemäß geerdete Wandsteckdose muß vorhanden sein.
- Ausreichender Freiraum für den Zugang zu den Netzkabeln, da diese die Hauptvorrichtung zum Trennen des Produkts von der Stromversorgung sind.

Handhabung von Geräten

Beachten Sie zur Vermeidung von Verletzungen oder Beschädigungen an den Geräten die folgenden Hinweise:

- Halten Sie beim Transportieren und Anheben von Geräten die örtlichen Gesundheits- und Sicherheitsvorschriften ein.
- Verwenden Sie mechanische oder andere geeignete Hilfsmittel zum Transportieren oder Anheben von Geräten.
- Entfernen Sie alle Komponenten, die sich leicht abnehmen lassen, um das Gewicht zu reduzieren und die Handhabung zu erleichtern.

Warnungen zu Netzspannung und Elektrizität

Caution: *Durch Betätigen der mit dem Standby-Symbol gekennzeichneten Netztaste wird das System NICHT vollständig vom Netz getrennt. Es sind weiterhin 5 V aktiv, solange das System eingesteckt ist. Um das System vollständig vom Strom zu trennen, muß das Netzkabel aus der Steckdose abgezogen werden. Das System verfügt möglicherweise über mehrere Netzkabel. Vergewissern Sie sich in diesem Fall, daß alle Netzkabel abgezogen sind. Wenn Sie Komponenten ein- oder ausbauen möchten, die nicht hot-plug-fähig sind, stellen Sie sicher, daß zuvor alle Netzkabel abgezogen sind.*

Nehmen Sie keine Änderungen am Netzkabel vor, und verwenden Sie kein Kabel, das nicht genau dem geforderten Typ entspricht. Jedes Netzteil im System muß über ein eigenes Netzkabel angeschlossen werden.

Einige Netzteile von Intel Servern verwenden Nullleitersicherungen. Vorsicht ist geboten im Umgang mit Netzteilen, welche Nullleitersicherungen verwenden, um das Risiko eines elektrischen Schlages zu vermeiden

Das Netzteil in diesem Produkt enthält keine Teile, die vom Benutzer gewartet werden können. Öffnen Sie das Netzteil nicht. Im Netzteil bestehen gefährliche Spannungen, Ströme und Energiequellen. Schicken Sie das Gerät für Wartungsarbeiten an den Hersteller zurück.

Wenn Sie ein hot-plug-fähiges Netzteil austauschen, ziehen Sie dessen Netzkabel ab, bevor Sie es aus dem Server ausbauen.

Zur Vermeidung von Stromschlägen schalten Sie den Server aus, und trennen Sie vor dem Öffnen des Geräts das Netzkabel sowie alle an den Server angeschlossene Telekommunikationssysteme, Netzwerke und Modems.

Hinweis für Netzkabel

Wenn kein Netzkabel mit dem Produkt geliefert wurde, kaufen Sie ein Kabel, das für die

Caution: *Prüfen Sie zur Vermeidung von Stromschlag oder Feuergefahr die mit dem Produkt zu verwendenden Netzkabel wie folgt:*

- *Nehmen Sie keine Änderungen an einem Netzkabel vor, und benutzen sie es nicht, wenn es nicht genau in die geerdeten Netzsteckdosen paßt.*
- *Netzkabel müssen die folgenden Anforderungen erfüllen:*
 - *Die Nennbelastbarkeit des Netzkabels muß mindestens so hoch sein wie die am Produkt angegebenen Nennstromaufnahme.*
 - *Das Netzkabel muß einen zur Netzsteckdose passenden Schutzkontakt besitzen.*
- *Die Netzkabel sind die Hauptvorrichtung zum Trennen des Geräts vom Stromnetz. Die Steckdose muß in der Nähe der Anlage angebracht und gut erreichbar sein.*
- *Netzkabel müssen an eine ordnungsgemäß geerdete Steckdose angeschlossen sein.*

Warnhinweise für den Systemzugang

Caution: Um Verletzungen und Beschädigungen zu vermeiden, sollten Sie vor Arbeiten im Produktinneren folgende Sicherheitsanweisungen beachten:

- Schalten Sie alle am Produkt angeschlossenen Peripheriegeräte aus.
- Schalten Sie das System mit dem Netzschalter aus.
- Trennen Sie das Gerät von der Stromquelle, indem Sie alle Netzkabel vom System bzw. aus der Steckdose ziehen.
- Ziehen Sie alle Kabel und alle an das System angeschlossenen Telekommunikationsleitungen ab.
- Bewahren Sie alle Schrauben und anderen Befestigungselemente gut auf, nachdem Sie die Gehäuseabdeckung entfernt haben. Wenn Sie Ihre Arbeiten im Systeminneren beendet haben, befestigen Sie die Gehäuseabdeckung mit den Originalschrauben bzw. -befestigungselementen.
- Führen Sie keine Arbeiten im Netzteil aus. Das Netzteil enthält keine für den Benutzer wartungsbedürftigen Teile. Schicken Sie das Gerät für Wartungsarbeiten an den Hersteller zurück.
- Schalten Sie den Server aus, und ziehen Sie alle Netzkabel ab, bevor Sie Komponenten ein- oder ausbauen, die nicht hot-plug-fähig sind.
- Wenn Sie ein hot-plug-fähiges Netzteil austauschen, ziehen Sie dessen Netzkabel ab, bevor Sie es aus dem Server ausbauen.

Caution: War Ihr Server in Betrieb, können die installierten Prozessoren und Kühlkörper heiß sein. Sofern Sie keine Hot-Plug-Komponenten ein- oder ausbauen, warten Sie mit dem Abnehmen der Abdeckungen, bis das System abgekühlt ist. Gehen Sie beim Aus- oder Einbauen von Hot-Plug-Komponenten sorgfältig vor, um nicht mit heißen Komponenten in Berührung zu kommen.

Caution: Berühren Sie nicht die rotierenden Lüfterflügel, um Verletzungen zu vermeiden. Falls Ihr System mit einer Lüfterabdeckung besitzt, darf es nicht ohne diese Abdeckung betrieben werden.

Warnhinweise für Racks

Das Geräte-Rack muß auf einer geeigneten, festen Unterlage verankert werden, um ein Umkippen zu vermeiden, wenn ein Server oder andere Geräte herausgezogen werden. Bei der Installation des Racks müssen die Anweisungen des Rack-Herstellers beachtet werden.

Gehen Sie bei der Installation von Geräten im Rack immer von unten nach oben vor, und bauen Sie das schwerste Gerät an der untersten Position im Rack ein.

Ziehen Sie jeweils immer nur ein Gerät aus dem Rack heraus.

Sie müssen für die gesamte Rack-Einheit einen Netztrennschalter einrichten. Dieser Netztrennschalter muß leicht zugänglich sein und über eine Kennzeichnung verfügen, die besagt, daß er die Stromzufuhr zur gesamten Einheit steuert und nicht nur zu den Servern.

Zur Vermeidung von Stromschlaggefahr müssen das Rack selbst und alle darin eingebauten Geräte ordnungsgemäß geerdet sein.

Elektrostatische Entladungen (ESD)

Caution: *Elektrostatische Entladungen können zur Beschädigung von Festplatten, Platinen und anderen Komponenten führen. Daher sollten Sie alle Arbeiten an einer ESD-Workstation ausführen. Steht ein solcher Arbeitsplatz nicht zur Verfügung, erzielen Sie einen gewissen Schutz vor elektrostatischen Entladungen durch Tragen einer Antistatik-Manschette, die Sie während der Arbeit zur Erdung an einem beliebigen unlackierten Metallteil des Computergehäuses befestigen.*

Gehen Sie bei der Handhabung von Platinen immer mit größter Vorsicht vor. Sie können äußerst empfindlich gegenüber elektrostatischer Entladung sein. Halten Sie Platinen nur an den Kanten fest. Legen Sie die Platinen nach dem Auspacken aus der Schutzhülle oder nach dem Ausbau aus dem Server mit der Bauelementseite nach oben auf eine geerdete, statisch entladene Unterlage. Verwenden Sie dazu, sofern verfügbar, eine leitfähige Schaumstoffunterlage, aber nicht die Schutzhülle der Platine. Ziehen Sie die Platine nicht über eine Fläche.

Andere Gefahren

Batterieaustausch

Caution: *Wird die Batterie unsachgemäß ausgetauscht, besteht Explosionsgefahr. Verwenden Sie als Ersatz nur die vom Gerätehersteller empfohlene Batterie.*

Beachten Sie bei der Entsorgung von Batterien die gültigen Bestimmungen.

Versuchen Sie nicht, eine Batterie aufzuladen.

Versuchen Sie nicht, eine Batterie zu öffnen oder sonstwie zu beschädigen.

Kühlung und Luftstrom

Caution: *Verlegen Sie Kabel sorgfältig entsprechend der Anleitung, um Störungen des Luftstroms und Kühlungsprobleme zu vermeiden.*

Zur Gewährleistung des ordnungsgemäßen Kühlungs- und Luftstromverhaltens darf das System nur mit angebrachten Gehäuseabdeckungen betrieben werden. Die Inbetriebnahme des Systems ohne Abdeckung kann zur Beschädigung von Systemkomponenten führen. So bringen Sie die Abdeckung wieder an:

- Vergewissern Sie sich zunächst, daß Sie keine Werkzeuge oder Teile im Gehäuse vergessen haben.

- Vérifiez si les câbles, les cartes d'extension et les autres composants sont correctement installés.
- Fixez les couvercles du boîtier du produit, comme décrit dans le manuel.

Laser-Peripheralgeräte oder -Komponenten

Caution: Beachten Sie zur Vermeidung von Strahlung und Verletzungen die folgenden Hinweise:

- Öffnen Sie keinesfalls das Gehäuse von Laser-Peripheralgeräten oder Laser-Komponenten.
- Laser-Peripheralgeräte oder -Komponenten besitzen keine für den Benutzer wartungsbedürftigen Teile.
- Schicken Sie das Gerät für Wartungsarbeiten an den Hersteller zurück.

Français

Consignes de sécurité sur le serveur

Ce document s'applique aux cartes serveur Intel[®], au châssis de serveur Intel[®] (sur pieds et sur rack) et aux périphériques installés. Pour réduire les risques de dommages corporels, d'électrocution, d'incendie et de dommages matériels, lisez ce document et respectez tous les avertissements et précautions mentionnés dans ce guide avant d'installer ou de mettre à jour votre produit serveur Intel[®].







En cas de conflit entre les informations fournies dans ce document et celles livrées avec le produit ou publiées sur le site Web pour un produit particulier, la documentation du produit prime.

Votre serveur doit être intégré et entretenu uniquement par des techniciens qualifiés.

Vous devez suivre les informations de ce guide et les instructions d'assemblage des manuels de serveur pour vérifier et maintenir la conformité avec les certifications et approbations de produit existantes. Utilisez uniquement les composants décrits et réglementés spécifiés dans ce guide. L'utilisation d'autres produits/composants annulera la liste UL et les autres approbations réglementaires du produit, et le produit peut ne pas être conforme aux autres lois et réglementations locales applicables au produit.

Sécurité: avertissements et mises en garde

Pour éviter de vous blesser ou d'endommager votre équipement, lisez et respectez toutes les informations et consignes de sécurité avant de commencer l'installation du produit. Les symboles de sécurité suivants peuvent être utilisés tout au long de cette documentation et peuvent figurer sur le produit ou sur son emballage.

ATTENTION	Indique la présence d'un risque pouvant entraîner des blessures physiques mineures ou endommager légèrement le matériel si la mise en garde n'est pas prise en compte.
AVERTISSEMENT	Indique la présence d'un risque pouvant entraîner des blessures corporelles graves si l'avertissement n'est pas pris en compte.
	Indique un risque potentiel si les informations signalées ne sont pas prises en compte.
	Indique des risques d'électrocution pouvant entraîner des blessures corporelles graves ou mortelles si les consignes de sécurité ne sont pas respectées.
	Signale des composants ou des surfaces soumis à des températures élevées.
	Indique de ne pas toucher aux pales de ventilateur, car cela peut entraîner des blessures.
	Indique de débrancher tous les cordons d'alimentation secteur pour déconnecter l'alimentation.
	Veuillez réutiliser la batterie

Domaines d'utilisation prévus

Ce produit a été testé comme équipement informatique (ITE) et peut être installé dans des bureaux, des écoles, des salles informatiques et des endroits commerciaux similaires. L'utilisation du présent produit dans des catégories et environnements de produits et domaines d'application (par exemple, le domaine médical, industriel, résidentiel, les systèmes d'alarme et les appareils de contrôle) autres qu'ITE doit faire l'objet d'évaluations supplémentaires.

Sélection d'un emplacement

Le système est conçu pour fonctionner dans un environnement standard de bureau. Choisissez un emplacement respectant les conditions suivantes :

- Propre, sec et exempt de particules en suspension (autres que la poussière normale d'une pièce).
- Bien ventilé et à l'écart des sources de chaleur telles que la lumière directe du soleil et les radiateurs.
- À l'écart des sources de vibration ou des chocs physiques.
- Isolé des champs électromagnétiques importants produits par des appareils électriques.

- Dans les régions sujettes aux orages magnétiques, nous vous recommandons de brancher votre système à un suppresseur de surtension et de déconnecter les lignes de télécommunication de votre modem pendant les orages.
- Équipé d'une prise murale reliée à la terre.
- Équipé d'un espace suffisant pour accéder aux cordons d'alimentation secteur, car ils servent de disjoncteur principal d'alimentation du produit.

Pratiques de manipulation de l'équipement

Réduisez le risque de dommages personnels ou matériels :

- Conformez-vous aux exigences de médecine du travail et de sécurité lorsque vous déplacez et soulevez le matériel.
- Utilisez l'assistance mécanique ou toute autre assistance appropriée lorsque vous déplacez et soulevez le matériel.
- Pour réduire le poids en vue de faciliter la manipulation, retirez tout composant amovible.

Alimentation et avertissements en matière d'électricité

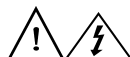

Attention: Le bouton d'alimentation, indiqué par le symbole de mise en veille, **NE COUPE PAS** complètement l'alimentation secteur du système car le courant de veille 5 V reste actif lorsque le système est sous tension. Pour couper l'alimentation du système, vous devez débrancher le cordon d'alimentation secteur de la prise murale. Votre système peut utiliser plusieurs cordons d'alimentation secteur. Assurez-vous que tous les cordons d'alimentation sont débranchés. Vous devez les débrancher avant d'ouvrir le châssis, d'ajouter ou de supprimer un composant non connectable à chaud.

Les alimentations de certains serveurs Intel sont munies de doubles fusibles pôle/neutre: veuillez observer les précautions d'usage afin d'éviter tout risque d'électrocution.

N'essayez pas de modifier ou d'utiliser un cordon d'alimentation secteur s'il ne s'agit pas du type exact requis. Un cordon secteur est requis pour chaque alimentation système.

Le bloc d'alimentation de ce produit ne contient aucun composant réparable par l'utilisateur. N'ouvrez pas le bloc d'alimentation. L'intérieur de celui-ci est soumis à des

niveaux dangereux de tension, de courant et d'énergie. Renvoyez-le au fabricant en cas de problème.

Lorsque vous remplacez un bloc d'alimentation à chaud, débranchez le cordon du bloc d'alimentation en cours de remplacement avant de le retirer du serveur.

Pour éviter tout risque d'électrocution, mettez le système hors tension et débranchez les cordons d'alimentation ainsi que les systèmes de télécommunication, réseaux et modems reliés au système avant d'ouvrir ce dernier.

Avertissements sur le cordon d'alimentation

Si aucun cordon d'alimentation secteur n'a été fourni avec votre produit, vous devez vous en procurer un qui soit approuvé pour une utilisation dans votre pays.



Attention: Pour éviter tout risque d'électrocution ou d'incendie, vérifiez les cordons d'alimentation qui seront utilisés avec le produit comme suit :

- N'essayez pas d'utiliser ou de modifier les cordons d'alimentation en CA s'ils ne correspondent pas exactement au type requis pour les prises électriques reliées à la terre.
- Les cordons d'alimentation doivent répondre aux critères suivants :
 - Le cordon d'alimentation doit supporter une intensité supérieure à celle indiquée sur le produit.
 - Le cordon d'alimentation doit posséder une broche ou un contact de mise à la terre approprié à la prise électrique.
- Les cordons d'alimentation électrique représentent le principal dispositif de déconnexion raccordé à l'alimentation secteur. Les prises de courant doivent se trouver à proximité de l'équipement et être facilement accessibles pour une déconnexion.
- Les cordons d'alimentation doivent être branchés sur des prises électriques correctement reliées à la terre.

Avertissements sur l'accès au système



Attention: Pour éviter de vous blesser ou d'endommager votre équipement, les consignes de sécurité suivantes s'appliquent chaque fois que vous accédez à l'intérieur du produit :

- Mettez hors tension tous les périphériques connectés à ce produit.
- Éteignez le système en appuyant sur le bouton d'alimentation.
- Déconnectez l'alimentation secteur en débranchant tous les cordons d'alimentation secteur du système ou de la prise murale.
- Déconnectez l'ensemble des câbles et lignes de télécommunication qui sont connectés au système.

- Mettez toutes les vis ou autres attaches de côté lorsque vous retirez les panneaux d'accès. Une fois que vous avez terminé d'accéder à l'intérieur du produit, refixez le panneau d'accès avec les vis ou attaches d'origine.
- N'essayez pas d'accéder à l'intérieur du bloc d'alimentation. Il ne contient aucune pièce réparable. Renvoyez-le au fabricant en cas de problème.
- Mettez le serveur hors tension et débranchez tous les cordons d'alimentation avant d'ajouter ou de remplacer tout composant non connectable à chaud.
- Lorsque vous remplacez le bloc d'alimentation à chaud, débranchez le cordon du bloc d'alimentation en cours de remplacement avant de retirer le bloc du serveur.



Attention: Si le serveur a été utilisé, les processeurs et dissipateurs de chaleur installés peuvent être chauds. À moins que vous n'ajoutiez ou ne retiriez un composant connectable à chaud, laissez le système refroidir avant d'ouvrir les panneaux. Pour éviter tout risque d'entrer en contact avec un composant chaud lors d'une installation à chaud, prenez toutes les précautions nécessaires lorsque vous retirez ou installez des composants connectables à chaud.



Attention: Pour éviter de vous blesser, ne touchez pas les pales de ventilateur en mouvement. Si votre système est fourni avec une protection sur le ventilateur, ne mettez pas le système en route sans la protection en place.

Avertissements sur le montage en rack

Le rack doit être fixé à un support inamovible pour éviter qu'il ne bascule lors de l'extension d'un serveur ou d'un élément de l'équipement. Le rack doit être installé conformément aux instructions du fabricant.

Installez les équipements dans le rack en partant du bas, en plaçant le plus lourd en bas du rack.

N'étendez qu'un seul élément de l'équipement à partir du rack à la fois.

Vous êtes responsable de l'installation d'un disjoncteur principal d'alimentation pour la totalité du rack. Ce disjoncteur principal doit être rapidement accessible et doit être étiqueté comme contrôlant toute l'unité, et pas uniquement le ou les serveurs.

Pour éviter tout risque d'électrocution, le rack et chaque élément de l'équipement installé dans le rack doivent être correctement reliés à la terre.

Décharges électrostatiques (ESD)



Attention: Les décharges électrostatiques (ESD) peuvent endommager les lecteurs de disque dur, les cartes et d'autres pièces. Il est fortement conseillé d'effectuer l'ensemble des procédures décrites à un poste de travail protégé contre les ESD. Au cas où aucun poste de ce type ne serait disponible, protégez-vous contre les ESD en portant un bracelet antistatique relié à la masse du châssis (n'importe quelle surface métallique non peinte) de votre serveur lorsque que vous manipulez les pièces.

Manipulez toujours les cartes avec précaution. Elles peuvent être extrêmement sensibles aux ESD. Ne tenez les cartes que par leurs bords. Après avoir retiré une carte de son emballage de protection ou du serveur, placez-la sur une surface reliée à la terre, exempte de charge statique, composants orientés vers le haut. Utilisez si possible un tapis de mousse conducteur, mais pas l'emballage de la carte. Veillez à ce que la carte ne glisse sur aucune surface.

Autres risques

Remplacement de la pile



Attention: Il existe un risque d'explosion si la pile n'est pas correctement remplacée. Lors du remplacement de la pile, utilisez uniquement celle recommandée par le fabricant du matériel.

Mettez la pile au rebut en vous conformant aux réglementations locales.

N'essayez pas de recharger une pile.

N'essayez pas de démonter, de percer ou d'endommager la pile d'une quelconque façon.

Refroidissement et ventilation



Attention: Routez les câbles avec précaution comme indiqué pour minimiser les blocages de circulation d'air et les problèmes de refroidissement.

Afin de permettre une ventilation et un refroidissement corrects, ne mettez le système en marche que lorsque les panneaux du châssis sont en place. L'utilisation du système sans les panneaux peut endommager les composants système. Pour installer les panneaux :

- Vérifiez tout d'abord que vous n'avez pas oublié d'outils ou de composants détachés à l'intérieur du système.
- Vérifiez que les câbles, les cartes d'extension et les autres composants sont correctement installés.
- Fixez les panneaux au châssis en suivant les instructions du produit.

Périphériques laser



Attention: *Pour éviter tout risque d'exposition aux rayonnements et/ou de dommage personnel:*

- *N'ouvrez pas l'enceinte d'un périphérique laser.*
- *Les périphériques laser ne sont pas réparables par l'utilisateur.*
- *Retournez-les au fabricant en cas de problème.*

Español

Información de seguridad del servidor

Este documento se aplica a las tarjetas de servidor de Intel[®], las carcasas de servidor de Intel[®] (montaje en bastidor y en pedestal) y los dispositivos periféricos. Para reducir el riesgo de daños corporales, descargas eléctricas, fuego y en el equipo, lea este documento y preste atención a todas las advertencias y precauciones de esta guía antes de instalar o mantener el producto de servidor de Intel[®].

En el caso de que haya diferencias entre la información para un producto en particular contenida en este documento y la información proporcionada con dicho producto o en el sitio Web, la documentación del producto es la que prevalece.







Sólo personal técnico cualificado debe montar y prestar los servicios para el servidor.

Debe ceñirse a las directrices de esta guía y a las instrucciones de montaje de los manuales del servidor para asegurar y mantener el cumplimiento con las certificaciones y homologaciones existentes de los productos. Utilice sólo los componentes descritos y homologados que se especifican en esta guía. El uso de otros productos o componentes anulará la homologación UL y otras certificaciones oficiales del producto, pudiendo dejar de ser compatible con las normativas locales de los países en los que se comercializa.

Advertencias y precauciones sobre seguridad

Para reducir la posibilidad de que se produzcan lesiones personales o daños en la propiedad, antes de empezar a instalar el producto, lea, observe y cumpla toda la información e instrucciones de seguridad siguientes. Puede que se utilicen los siguientes símbolos de seguridad en la documentación y es posible que aparezcan en el producto o en su embalaje.

PRECAUCIÓN	Indica la existencia de un riesgo que podría causar lesiones personales o daños en la propiedad leves si no se tiene en cuenta la PRECAUCIÓN.
ADVERTENCIA	Indica la existencia de un riesgo que podría causar lesiones personales graves si no se tiene en cuenta la ADVERTENCIA.

	Indica un riesgo potencial si no se tiene en cuenta la información indicada.
	Indica riesgo de descargas eléctricas que podrían causar lesiones graves o la muerte si no se siguen las instrucciones de seguridad.
	Indica componentes o superficies calientes.
	Indica que no se deben tocar las aspas de los ventiladores, ya que de lo contrario se podrían producir lesiones.
	Indica que es necesario desenchufar los cables de alimentación de CA para desconectar la alimentación de CA
	Recicle por favor la batería

Aplicaciones y usos previstos

Este producto ha sido evaluado como equipo de tecnología informática (ITE) que puede instalarse en oficinas, escuelas, salas de equipos informáticos o lugares de ámbito comercial similares. Es posible que sea necesario llevar a cabo una evaluación adicional para comprobar si este producto es apropiado para otras categorías de productos y entornos además de las aplicaciones informáticas (por ejemplo, soluciones médicas, industriales, residenciales, sistemas de alarma y equipos de pruebas).

Selección de la ubicación

El sistema se ha diseñado para funcionar en un entorno normal de oficinas. Seleccione una ubicación que esté:

- Limpia, seca y libre de macropartículas en suspensión en el aire (que no sean el polvo habitual de la habitación).
- Bien ventilada y alejada de fuentes de calor, incluida la luz solar directa y los radiadores.
- Alejada de fuentes de vibración o de golpes físicos.
- Aislada de campos electromagnéticos producidos por dispositivos eléctricos.
- En zonas propensas a tormentas eléctricas, se recomienda que conecte el servidor a un supresor de sobretensiones y desconecte las líneas de telecomunicaciones al módem durante una tormenta eléctrica.
- Provista de una toma de corriente alterna correctamente conectada a tierra.
- Provista de espacio suficiente para acceder a los cables de la fuente de alimentación ya que constituyen la desconexión principal de la alimentación.

Manipulación del equipo

Reduzca el riesgo de daños personales o en el equipo:

- Respete los requisitos de sanidad y seguridad laborales de su país cuando traslade y levante el equipo.
- Utilice medios mecánicos u otros que sean adecuados al trasladar o levantar el equipo.
- Para que el peso sea menor para manipularlo con más facilidad, extraiga los componentes que sean de fácil extracción.

Advertencias de alimentación y eléctricas



Precaución: El botón de encendido, indicado con la marca del modo de reposo o stand-by, NO DESCONECTA completamente la alimentación de CA del sistema, ya que el modo de reposo de 5 V sigue activo mientras el sistema está enchufado. Para desconectar el sistema debe desenchufar el cable de alimentación de CA de la toma de la pared. Puede usar más de un cable de alimentación de CA con el sistema. Asegúrese de que todos los cables de alimentación de CA están desenchufados. Asegúrese de que los cables de alimentación de CA estén desenchufado antes de abrir la carcasa, agregar o extraer cualquier componente que no es de conexión en funcionamiento.

Algunas fuentes de alimentación de electricidad de los servidores de Intel utilizan el polo neutral del fuselaje. Para evitar riesgos de choques eléctricos use precauciones al trabajar con las fuentes de alimentación que utilizan el polo neutral de fuselaje.

No intente modificar ni utilizar un cable de alimentación de CA si no es del tipo exacto requerido. Se necesita un cable de CA para cada fuente de alimentación del sistema.

La fuente de alimentación de este producto no contiene piezas que puedan ser reparadas por el usuario. No abra la fuente de alimentación. Dentro de la fuente de alimentación puede haber niveles de tensión, corriente y energía peligrosos. Devuélvala al fabricante para repararla.

Al reemplazar una fuente de alimentación de conexión en funcionamiento, desenchufe el cable de alimentación de la fuente de alimentación que va a reemplazar antes de extraerla del servidor.

Para evitar el riesgo de descargas eléctricas, antes de abrir el servidor, apáguelo, desconecte el cable de alimentación, los sistemas de telecomunicaciones, las redes y los módems conectados al mismo.

Advertencias sobre el cable de alimentación

Si no se ha proporcionado con el producto ningún cable de alimentación de CA, adquiera alguno cuyo uso esté aprobado en su país.



Precaución: Para evitar descargas eléctricas o fuego, revise los cables de alimentación que usará con el producto tal y como se describe a continuación:

- No intente modificar ni utilizar los cables de alimentación de CA si no son exactamente del modelo especificado para ajustarse a las tomas de corriente conectadas a tierra.
- Los cables de alimentación deben reunir los siguientes requisitos:
 - El cable de alimentación debe disponer de una capacidad nominal de corriente eléctrica mayor que la capacidad especificada en el producto.
 - El cable de alimentación debe disponer de una patilla o contacto de conexión a tierra que sea apto para la toma de corriente.
- Los cables de la fuente de alimentación son los dispositivos de desconexión principales a la corriente alterna. El enchufe o enchufes de zócalo deben encontrarse cerca del equipo y el acceso a ellos debe poderse efectuar de forma inmediata con el fin de desconectarlos.
- Los cables de la fuente de alimentación deben estar conectados a los enchufes con una toma de tierra adecuada.

Advertencias el acceso al sistema



Precaución: Para evitar lesiones personales o daños en la propiedad, se aplican las siguientes instrucciones de seguridad siempre que se acceda al interior del producto:

- Apague todos los dispositivos periféricos conectados a este producto.
- Pulse el botón de alimentación para apagar el sistema.
- Desconecte la alimentación de CA desenchufando los cables de alimentación de CA del sistema o de la toma de corriente alterna.
- Desconecte todos los cables y líneas de telecomunicación que estén conectados al sistema.
- Guarde todos los tornillos o elementos de fijación cuando retire las cubiertas de acceso. Cuando termine de operar en el interior del producto, vuelva a colocar los tornillos o los elementos de fijación originales de la cubierta de acceso.
- No acceda al interior de la fuente de alimentación. No hay elementos en la fuente de alimentación que usted pueda reparar y utilizar. Devuélvala al fabricante para repararla.
- Apague el servidor y desconecte todos los cables de alimentación antes de agregar o reemplazar cualquier componente que no es de conexión en funcionamiento.

- *Al reemplazar una fuente de alimentación de conexión en funcionamiento, desenchufe el cable de alimentación de la fuente de alimentación que va a reemplazar antes de extraerla del servidor.*



Precaución: Si el servidor se ha estado ejecutando, los procesadores y disipadores de calor estarán recalentados. A no ser que esté instalando o extrayendo un componente de conexión en funcionamiento, deje que el sistema se enfríe antes de abrir las cubiertas. Para que no llegue a tocar los componentes que estén calientes cuando esté realizando una instalación de conexión en funcionamiento, tenga cuidado al extraer o instalar los componentes de conexión en funcionamiento.



Precaución: Para evitar posibles daños, no toque las aspas en movimiento de los ventiladores. Si el sistema se le ha suministrado con una protección para el ventilador, asegúrese de que cuando esté funcionando el sistema la protección esté en su sitio.

Advertencias sobre el montaje en bastidor

El bastidor del equipo se debe sujetar con un soporte fijo para evitar que se caiga cuando se extraiga un servidor o una pieza del mismo. El bastidor del equipo debe instalarse siguiendo las instrucciones del fabricante del bastidor.

Instale el equipo en el bastidor comenzando desde la parte de abajo, con el equipo más pesado en la parte inferior del bastidor.

Extraiga las piezas del equipo del bastidor de una a una.

El usuario es el responsable de la instalación de un dispositivo de desconexión de la alimentación principal para toda la unidad del bastidor. El acceso a este dispositivo de desconexión deberá ser de fácil acceso y deberán incluirse indicaciones que lo identifiquen como el control de alimentación eléctrica de toda la unidad, no sólo de los servidores.

Para evitar el riesgo de descargas eléctricas, deberá instalar una conexión a tierra apropiada para el bastidor y para cada pieza del equipo instalada en el mismo.

Descarga electrostática (ESD)



Precaución: Las descargas electrostáticas pueden dañar las unidades de disco, las tarjetas y otros componentes. Recomendamos que realice todos los procedimientos en una estación de trabajo protegida contra descargas electrostáticas. En caso de que no haya una

disponible, protéjase de alguna forma contra las descargas llevando un brazalete antiestático conectado a la toma de tierra de la carcasa (cualquier superficie de metal que no esté pintada) del servidor cuando manipule las piezas.

Manipule siempre las tarjetas con el máximo cuidado. Pueden ser sumamente sensibles a las descargas electrostáticas. Sujételas sólo por los bordes. Una vez extraída la tarjeta de su envoltorio de protección o del servidor, colóquela con el lado de los componentes hacia arriba sobre una superficie con toma de tierra y sin carga estática. Utilice una almohadilla de espuma conductora si dispone de ella, pero nunca el envoltorio de la tarjeta. No deslice la tarjeta sobre ninguna superficie.

Otros riesgos

Sustitución de la batería



Precaución: Existe el peligro de explosión si la batería no se reemplaza correctamente. Al reemplazar la batería, utilice sólo la batería recomendada por el fabricante del equipo.

Deseche las baterías respetando la normativa local.

No intente recargar la batería.

No intente desmontar, pinchar o causar cualquier otro desperfecto a una batería.

Enfriamiento y circulación de aire



Precaución: El tendido de los cables debe realizarse cuidadosamente tal y como se le indica para reducir al mínimo los problemas de obstrucción de la ventilación y de refrigeración.

Para conseguir una refrigeración y corriente de aire adecuadas, compruebe que cuando sistema esté funcionando, las cubiertas de la carcasa están instaladas. Si utiliza el sistema sin las cubiertas, podría dañar sus componentes. Para instalar las cubiertas:

- Compruebe primero que no ha dejado herramientas o piezas sueltas dentro del sistema.*
- Compruebe que los cables, tarjetas adicionales y otros componentes están instalados correctamente.*
- Sujete las cubiertas a la carcasa siguiendo las instrucciones del producto.*

Periféricos o dispositivos láser



Precaución Para evitar el riesgo de la exposición a radiaciones o de daños personales:

- *No abra la caja de ningún periférico o dispositivo láser.*
- *Los periféricos o dispositivos láser no pueden ser reparados por el usuario.*
- *Haga que el fabricante los repare.*

