

Intel[®] Server System R1000JP Family Service Guide

A Guide for Technically Qualified Assemblers of Intel[®] Identified Subassemblies/Products

Order Number: G68266-002

Disclaimer

Disclaimer

Information in this document is provided in connection with Intel® products. No license, express or implied, by estoppel or otherwise, to any intellectual property rights is granted by this document. Except as provided in Intel®'s Terms and Conditions of Sale for such products, Intel® assumes no liability whatsoever, and Intel® disclaims any express or implied warranty, relating to sale and/or use of Intel® products including liability or warranties relating to fitness for a particular purpose, merchantability, or infringement of any patent, copyright or other intellectual property right. Intel® products are not designed, intended or authorized for use in any medical, lifesaving, or life sustaining applications or for any other application in which the failure of the Intel® product could create a situation where personal injury or death may occur. Intel® may make changes to specifications and product descriptions at any time, without notice.

Intel® server boards contain a number of high-density VLSI and power delivery components that need adequate airflow for cooling. Intel®'s own chassis are designed and tested to meet the intended thermal requirements of these components when the fully integrated system is used together. It is the responsibility of the system integrator that chooses not to use Intel® developed server building blocks to consult vendor datasheets and operating parameters to determine the amount of airflow required for their specific application and environmental conditions. Intel Corporation cannot be held responsible if components fail or the server board does not operate correctly when used outside any of their published operating or non-operating limits.

Intel, Intel Pentium, and Intel Xeon are trademarks or registered trademarks of Intel Corporation or its subsidiaries in the United States and other countries.

* Other names and brands may be claimed as the property of others.

Copyright © 2013 Intel Corporation. All Rights Reserved.

Safety Information

Important Safety Instructions

Read all caution and safety statements in this document before performing any of the instructions. See also *Intel® Server Boards and Server Chassis Safety Information* on the Intel® Server Deployment Toolkit 3.0 CD and/or at <http://www.intel.com/support/motherboards/server/sb/cs-010770.htm>.

Wichtige Sicherheitshinweise

Lesen Sie zunächst sämtliche Warnung und Sicherheitshinweise in diesem Dokument, bevor Sie eine der Anweisungen ausführen. Beachten Sie hierzu auch die Sicherheitshinweise zu *Intel®-Serverplatinen und Servergehäusen* auf der Intel® Server Deployment Toolkit 3.0 CD oder unter <http://www.intel.com/support/motherboards/server/sb/cs-010770.htm>.

Consignes de sécurité

Lisez attention toutes les consignes de sécurité et les mises en garde indiquées dans ce document avant de suivre toute instruction. Consultez *Intel® Server Boards and Server Chassis Safety Information* sur le Intel® Server Deployment Toolkit 3.0 CD ou bien rendez-vous sur le site <http://www.intel.com/support/motherboards/server/sb/cs-010770.htm>.

Instrucciones de seguridad importantes

Lea todas las declaraciones de seguridad y precaución de este documento antes de realizar cualquiera de las instrucciones. Vea *Intel® Server Boards and Server Chassis Safety Information* en el Intel® Server Deployment Toolkit 3.0 CD y/o en <http://www.intel.com/support/motherboards/server/sb/cs-010770.htm>.

重要安全指导

在执行任何指令之前，请阅读本文档中的所有注意事项及安全声明。和/或 <http://www.intel.com/support/motherboards/server/sb/cs-010770.htm> 上的 *Intel® Server Boards and Server Chassis Safety Information*（《Intel® 服务器主板与服务器机箱安全信息》）。

Warnings

Warnings

Heed safety instructions: Before working with your server product, whether you are using this guide or any other resource as a reference, pay close attention to the safety instructions. You must adhere to the assembly instructions in this guide to ensure and maintain compliance with existing product certifications and approvals. Use only the described, regulated components specified in this guide. Use of other products/components will void the UL listing and other regulatory approvals of the product and will most likely result in noncompliance with product regulations in the region(s) in which the product is sold.

System power on/off: The power button DOES NOT turn off the system AC power. To remove power from the system, you must unplug the AC power cord from the wall outlet. Make sure the AC power cord is unplugged before you open the chassis, add, or remove any components.

Hazardous conditions, devices and cables: Hazardous electrical conditions may be present on power, telephone, and communication cables. Turn off the server and disconnect the power cord, telecommunications systems, networks, and modems attached to the server before opening it. Otherwise, personal injury or equipment damage can result.

Electrostatic discharge (ESD) and ESD protection: ESD can damage disk drives, boards, and other parts. We recommend that you perform all procedures in this chapter only at an ESD workstation. If one is not available, provide some ESD protection by wearing an antistatic wrist strap attached to chassis ground—any unpainted metal surface—on your server when handling parts.

ESD and handling boards: Always handle boards carefully. They can be extremely sensitive to ESD. Hold boards only by their edges. After removing a board from its protective wrapper or from the server, place the board component side up on a grounded, static free surface. Use a conductive foam pad if available but not the board wrapper. Do not slide board over any surface.

Installing or removing jumpers: A jumper is a small plastic encased conductor that slips over two jumper pins. Some jumpers have a small tab on top that you can grip with your fingertips or with a pair of fine needle nosed pliers. If your jumpers do not have such a tab, take care when using needle nosed pliers to remove or install a jumper; grip the narrow sides of the jumper with the pliers, never the wide sides. Gripping the wide sides can damage the contacts inside the jumper, causing intermittent problems with the function controlled by that jumper. Take care to grip with, but not squeeze, the pliers or other tool you use to remove a jumper, or you may bend or break the pins on the board.

Preface

About this Manual

This manual is written for system technicians who are responsible for troubleshooting, upgrading, and repairing this server system. This document provides a brief overview of the features of the server board/chassis, a list of accessories or other components you may need, troubleshooting information, and instructions on how to add and replace components on the Intel® Server System R1000JP family products. For the latest revision of this manual, go to http://www.intel.com/p/en_US/support.

Table 1. Intel® Server System R1000JP family product list

| Product Code | Description |
|---------------------------------|---|
| Intel® Server System R1304JP4GS | With one S1600JP4 board, 4x3.5" hard drive bay, 1x 750W Power supply |
| Intel® Server System R1208JP4GS | With one S1600JP4 board, 8x2.5" hard drive bay, 1x 750W Power supply |
| Intel® Server System R1304JP4OC | With one S1600JP4 board, 4x3.5" hard drive bay, 2x 450W redundant AC Power supply |
| Intel® Server System R1208JP4OC | With one S1600JP4 board, 8x2.5" hard drive bay, 2x 450W redundant AC Power supply |
| Intel® Server System R1304JP4TC | With one S1600JP4 board, 4x3.5" hard drive bay, 2x 450W redundant DC Power supply |
| Intel® Server System R1208JP4TC | With one S1600JP4 board, 8x2.5" hard drive bay, 2x 450W redundant DC Power supply |

Manual Organization

Chapter 1 provides a brief overview of the Intel® Server System R1000JP family. In this chapter, you will find a list of the server system features, and figures of the system and components to help you identify your system components and their locations.

Chapter 2 provides instructions on adding and replacing components. Use this chapter for step-by-step instructions and diagrams for installing or replacing components such as the fan, power supply, and front panel board, among other components.

Chapter 3 provides instructions on using the utilities that are shipped with the board or that may be required to update the system. This includes information for navigating through the BIOS Setup screens, performing a BIOS update, and resetting the password or BIOS defaults.

At the back of this document, you will find appendices on safety, “Getting Help”, and warranty information.

Additional Information and Software

For additional information about this family of products or any of their supported accessories, refer to the following resources available at <http://www.intel.com/support>.

Preface

Table 2. Server System References

| For this information or software | Use this Document or Software |
|--|---|
| For in-depth technical information about this product | <i>Intel® Server System R1000JP Family Technical Product Specification</i> See the section on the web page titled, “Architecture/Specifications”. |
| For installation of supported spares and accessories | <i>Intel® Server System R1000JP Family Quick Installation User’s Guide</i> See the section on the web page titled, “System Integration/User Guides/Compatibility”. |
| For a list of supported Intel® spares and accessories | <i>Spares and Configuration Guide</i> See the section on the web page titled, “Documents & Guides”. |
| For server configuration guidance and compatibility | Intel® Server Configurator tool http://serverconfigurator.intel.com/sct_app.asp . |
| For system power budget guidance | Power Budget Analysis Tool in the Intel Deployment Assistant DVD |
| For software to manage your Intel® Server System | Intel® Server Management Software See the section on the web page titled, “Software/Code”. |
| For system firmware updates and onboard device drivers | Intel® Deployment Assistant DVD Firmware and Drivers See the section on the web page titled, “Software/Code”. |
| <i>Product Safety and Regulatory document</i> | <i>Intel® Server Products - Product Safety and Regulatory Compliance Document</i> See the section on the web page titled, “Regulations/Certification/Compliance”. |

Table of Contents

| | |
|--|------------|
| Safety Information | iii |
| Preface | v |
| 1 Server System Features | 1 |
| Server System Feature Overview | 1 |
| Server System Components | 4 |
| Front Panel | 5 |
| Back Panel | 5 |
| Server Board Components | 6 |
| Intel® Light-Guided Diagnostics | 7 |
| System Jumpers | 8 |
| Hard Disk Drive Carriers | 9 |
| Bezel 9 | |
| Hot-Swap SAS/SATA Backplane | 9 |
| Advanced Management Options | 10 |
| 2 Hardware Installations and Upgrades | 12 |
| Before You Begin | 12 |
| Tools and Supplies Needed | 12 |
| System Reference | 12 |
| Cable Routing | 12 |
| Removing and Installing the Front Bezel | 18 |
| Removing the Front Bezel | 18 |
| Installing the Front Bezel | 19 |
| Removing and Installing the System Top Cover | 19 |
| Removing the System Top Cover | 19 |
| Installing the System Cover | 20 |
| Fan Connections | 21 |
| Removing the Air Duct | 22 |
| Installing the Air Duct | 23 |
| Removing and Installing Processor | 24 |
| Removing Processor Heatsink | 24 |
| Installing the Processor | 24 |
| Installing Processor Heatsink(s) | 27 |
| Installing and Removing Memory | 28 |
| Installing Memory | 28 |
| Removing Memory | 29 |
| Installing and Removing Hot-swap Hard Drive | 29 |
| Installing a 3.5" Hard Disk Drive into 3.5" Hard Drive Carrier | 29 |
| Installing a Hard Disk Drive into 2.5" Hard Drive Carrier | 30 |
| Installing and Removing the PCIe Riser Assembly | 32 |
| On Riser Slot 1 | 32 |
| Installing the PCI Riser Assembly and add-in card | 32 |
| On Riser Slot 2 | 33 |
| Installing IOM riser and carrier assembly | 33 |
| On Riser Slot 3 | 35 |

Table of Contents

| | |
|---|-----------|
| Installing Double Width PCIe Add-in Card | 35 |
| Installing the Intel® RMM4 Lite..... | 36 |
| Installing the Intel® Storage Upgrade Key | 36 |
| Installing the Intel® Storage Upgrade Key | 36 |
| Installing and Removing the Fan | 37 |
| Removing the Fan set..... | 37 |
| Installing the Fan set..... | 37 |
| Installing and Removing the 2.5" Backplane Board..... | 38 |
| Removing the 2.5" Backplane board..... | 38 |
| Installing the 2.5" Backplane board..... | 38 |
| Installing and Removing the 3.5" Backplane Board..... | 39 |
| Removing the 3.5" Backplane board..... | 39 |
| Installing the 3.5" Backplane board..... | 40 |
| Installing and Removing the Power Distribution Board | 40 |
| Removing the PDB | 40 |
| Installing the PDB | 41 |
| Replacing the Backup Battery | 42 |
| Rack Mounting the Chassis | 42 |
| Mounting the Chassis to the Rack..... | 42 |
| 3 Server Utilities | 45 |
| Using the BIOS Setup Utility | 45 |
| Starting Setup | 45 |
| Setup Navigation Keyboard Commands | 45 |
| Setup Screen Menu Selection Bar | 46 |
| BIOS Setup Utility Screens..... | 46 |
| Map of Screens and Functionality | 47 |
| Appendix A: Technical Reference..... | 49 |
| System Environmental Specifications | 49 |
| Appendix B: Regulatory and Compliance Information..... | 50 |
| Appendix C: LED Decoder..... | 51 |
| Appendix D: Getting Help..... | 62 |
| Warranty Information | 62 |
| Appendix E: Intel® Server Issue Report Form | 63 |

List of Figures

| | |
|---|----|
| Figure 1. Intel® Server System R1000JP Family (8 * 2.5" HDDs) | 1 |
| Figure 2. Intel® Server System R1000JP Overview R1304JP4GS as demonstrated) | 4 |
| Figure 3. Front View of Intel® Server System R1304JP4 with 4x3.5" HDD bays | 4 |
| Figure 4. Front View of Intel® Server System R1208JP4 with 8x2.5" HDD bays | 4 |
| Figure 5. Front View of Intel® Server System R1208JP4 with 8x2.5" HDD bays | 5 |
| Figure 6. Back Panel Feature Identification | 5 |
| Figure 7. Server Board S1600JP4 Connector and Component Locations | 6 |
| Figure 8. Intel® Light-Guided Diagnostic LEDs - Server Board | 7 |
| Figure 9. Configuration Jumpers | 9 |
| Figure 10. Front view of System Bezel..... | 9 |
| Figure 11. 4 x 3.5-inch Hard Drive Backplane Components (Front View)..... | 9 |
| Figure 12. 4 x 3.5-inch Hard Drive Backplane Components (Rear View) | 10 |
| Figure 13. 8 x 2.5-inch Hard Drive Backplane Components (Front View)..... | 10 |
| Figure 14. 8 x 2.5-inch Hard Drive Backplane Components (Rear View) | 10 |
| Figure 15. Cable Routing for R1304JP4GS | 13 |
| Figure 16. Cable Routing for R1208JP4GS | 14 |
| Figure 17. Cable Routing for R1304JP4OC | 15 |
| Figure 18. Cable Routing for R1208JP4OC | 16 |
| Figure 19. Cable Routing for R1304JP4TC | 17 |
| Figure 20. Cable Routing for R1208JP4TC | 18 |
| Figure 21. Removing the Front Bezel..... | 19 |
| Figure 22. Installing the Front Bezel..... | 19 |
| Figure 23. Removing the System Top Cover | 20 |
| Figure 24. Installing the System Cover | 21 |
| Figure 25. System Fan Order (R1304JP4GS as showed)..... | 21 |
| Figure 26. Connecting the Fan Power Cables to the Mother Board..... | 22 |
| Figure 27. Removing the Air Duct | 23 |
| Figure 28. Installing the Air Duct | 23 |
| Figure 29. Removing the heatsink..... | 24 |
| Figure 30. Installing Processor – Open the Socket Lever | 25 |
| Figure 31. Installing Processor – Open the Load Plate | 25 |
| Figure 32. Installing Processor – Install the Processor..... | 26 |
| Figure 33. Installing Processor – Remove the Cover | 26 |
| Figure 34. Installing Processor – Close the Load Plate | 26 |
| Figure 35. Installing Processor – Latch the Locking Lever | 27 |
| Figure 36. Installing Processor Heatsinks..... | 28 |
| Figure 37. Installing Memory | 29 |
| Figure 38. Installing Hard Disk Drive – Removing the drive carrier..... | 29 |
| Figure 39. Installing Hard Disk Drive – Removing the screws..... | 30 |
| Figure 40. Installing Hard Disk Drive – assembling 3.5" HDD | 30 |
| Figure 41. Installing Hard Disk Drive – Inserting 3.5" HDD assembly..... | 30 |
| Figure 42. Installing Hard Disk Drive - Inserting | 31 |
| Figure 43. Installing Hard Disk Drive – Installing 2.5" HDD to Carrier..... | 31 |
| Figure 44. Installing Hard Disk Drive – Installing 2.5" HDD to Carrier..... | 31 |
| Figure 45. Installing Hard Disk Drive – Inserting 2.5" HDD Assembly | 32 |
| Figure 46. Removing the Riser with Bracket..... | 32 |
| Figure 47. Installing Riser 1 Assembly | 33 |

List of Figures

| | |
|---|----|
| Figure 48. Installing a PCI Adapter to PCI Riser 1 Assembly..... | 33 |
| Figure 49. Installing IO Module..... | 34 |
| Figure 50. Installing IO module..... | 34 |
| Figure 51. Installing Assembly to Riser..... | 34 |
| Figure 52. Fastening the Assembly in Chassis..... | 35 |
| Figure 53. Installing a PCI Adapter to PCI Riser 3 Assembly..... | 35 |
| Figure 54. Installing the Intel® RMM4 Lite..... | 35 |
| Figure 55. Installing the Intel® Storage Upgrade Key..... | 37 |
| Figure 56. Removing the Fan..... | 37 |
| Figure 57. Installing the Fan..... | 38 |
| Figure 58. Removing the 2.5" Backplane Board..... | 38 |
| Figure 59. Align the Backplane to the Clamps on the Chassis Base..... | 39 |
| Figure 60. Removing the 3.5" Backplane Board..... | 39 |
| Figure 61. Installing the 3.5" Backplane Board..... | 40 |
| Figure 62. Removing the PDB..... | 41 |
| Figure 63. Installing the PDB..... | 41 |
| Figure 64. Mounting the Chassis to the Rack..... | 41 |
| Figure 65. Installing Slides to the Rack..... | 44 |
| Figure 66. Installing Inner Member to the Chassis..... | 44 |
| Figure 67. Diagnostic LED Placement Diagram..... | 51 |

List of Tables

| | |
|--|----|
| Table 1. Intel® Server System R1000JP family product list | v |
| Table 2. Server System References..... | vi |
| Table 3. Intel® Server System R1000JP Feature Summary | 1 |
| Table 4. Hard Disk Drive Options | 9 |
| Table 5. Intel® RAID C600-A Storage Upgrade Key Options for S1600JP..... | 36 |
| Table 6. BIOS Setup: Keyboard Command Bar | 45 |
| Table 7. Screen Map | 47 |
| Table 8. System Environmental Limits Summary | 49 |
| Table 9. POST Progress Code LED Example..... | 52 |
| Table 10. Diagnostic LED POST Code Decoder..... | 52 |

List of Tables

<This page is intentionally left blank.>

1 Server System Features

This chapter briefly describes the main features of the Intel® Server System R1000JP family. This includes illustrations of the products, a list of the server system features, and diagrams showing the location of important components and connections on the server systems.

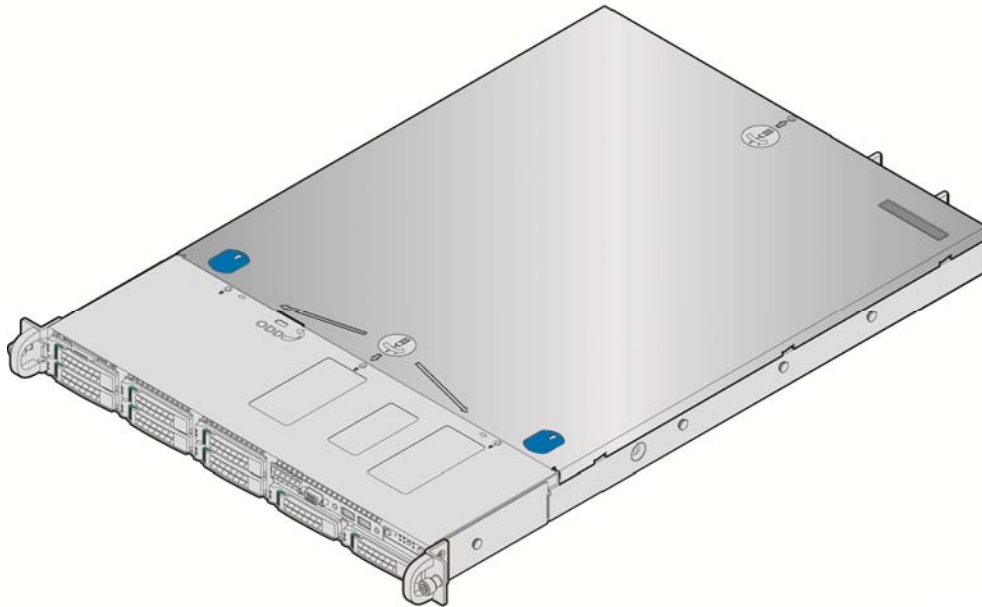

AF004992

Figure 1. Intel® Server System R1000JP Family (8 * 2.5" HDDs)

Server System Feature Overview

Table 3 summarizes the features of the server systems.

Table 3. Intel® Server System R1000JP Feature Summary

| Feature | Description |
|--------------------------------|---|
| Dimensions | <ul style="list-style-type: none"> ▪ 1.7 inches (43.2 mm) height. ▪ 17.24 inches (438.0 mm) wide (w/o rack handle). ▪ 25.2 inches (640 mm) deep (depth of handle and HDD carrier is not included). ▪ 33pounds (15kg) –roughly maximum system weight. |
| Compute Node Processor Support | <ul style="list-style-type: none"> ▪ Support for one Intel® Xeon® processor E5-2600 series with a Thermal Design Power (TDP) of up to 135W (Heatsink product code: FXXE84X106HS). ▪ Support for one Intel® Xeon® processor E5-1600 series with a Thermal Design Power (TDP) of up to 130W (Heatsink product code: FXXCA84X106HS). |
| Compute Node Memory | <ul style="list-style-type: none"> ▪ Maximum DIMM Capacity: 32GB DIMMs. ▪ Unbuffered DDRIII, Registered DDRIII and Load Reduced DDRIII. ▪ Memory DDRIII data transfer rate of 1066/1333/1600MT/s. |

Server System Features

| Feature | Description |
|--|---|
| | <ul style="list-style-type: none"> ▪ Four memory channels, two DIMM slots per channel. ▪ DDRIII standard I/O voltage of 1.5V (all speed) and DDRIII Low Voltage of 1.35V (1333MT/s or below). |
| Chipset on each Compute Node | Intel® C600-A chipset with support for optional Storage Upgrade Keys. |
| Compute Node External I/O connections | <ul style="list-style-type: none"> ▪ DB-15 Video connectors. ▪ Four RJ-45 Network Interface for 10/100/1000 LAN. ▪ One stacked two port USB 2.0 (Port 0/1) connectors. ▪ One dedicated 1GbE management port on rIOM carrier (optional). |
| Internal I/O Connections/headers | <ul style="list-style-type: none"> ▪ One Type A USB connector. ▪ Two 2 x 5 USB connectors. ▪ One 2 x 5 serial port connector. ▪ One internal video connector for the front video. ▪ Six SATA connectors. ▪ One mini SAS connector. |
| Available I/O Module Options (Sold Separately) | <p>The following I/O modules utilize a single proprietary on-board connector. An installed I/O module can be supported in addition to standard on-board features and any add-in expansion cards.</p> <ul style="list-style-type: none"> ▪ Quad Port Intel® I350 GbE I/O Module. ▪ Dual Port Intel® X540 10GbE I/O Module. ▪ Dual Port Intel® 82599 10GbE I/O Module. |
| System Fans by each Compute Node | <ul style="list-style-type: none"> ▪ Four System Fans on R1304JP4OC/R1208JP4OC/R1304JP4TC/R1208JP4TC. ▪ Five System Fans on R1304JP4GS/R1208JP4GS. |
| Riser Slot and Riser Card Options | <p>R1304JP4OC/R1208JP4OC and R1304JP4TC/R1208JP4TC.</p> <ul style="list-style-type: none"> ▪ Riser slot 1 support PCIe Gen III x16 Riser with LP PCIe add-in card. ▪ Riser slot 2 supports PCIe Gen III x 8 Riser (for Intel® rIOM and RMM4 NIC port). This riser and the carrier board are not integrated in the system. Please refer to the product order code A1UJPRMM4IOM. ▪ Riser slot 3 supports two slots Riser (PCIe Gen III x16 + x8) with full length and full height PCIe add-in card. <p>R1304JP4GS/R1208JP4GS:</p> <ul style="list-style-type: none"> ▪ Riser slot 1 support PCIe Gen III x16 Riser with LP PCIe add-in card. ▪ Riser slot 2 supports PCIe Gen III x 8 Riser (for Intel® rIOM and RMM4 NIC port). This riser and the carrier board are not integrated in the system. Please refer to the product order code A1UJPRMM4IOM. ▪ Riser slot 3 supports PCIe Gen III x16 Riser with Double width PCIe add-in card. |
| Node Video | <ul style="list-style-type: none"> ▪ Integrated 2D Video Controller. ▪ 128 MB DDR3 Memory. |
| System storage controllers and options | <p>R1304JP4GS/R1304JP4OC/R1304JP4TC:</p> <ul style="list-style-type: none"> ▪ One Mini SAS connector to the backplane to support 4-port SATA/SAS 3 Gb/sec. ▪ Intel® ESRT2 SAS/SATA RAID 0,1,5,10, or Intel® RSTe SATA RAID 0,1,5, and 10. ▪ Intel® RAID C600 Upgrade Key support providing optional expanded SATA/SAS RAID capabilities. <p>R1208JP4GS/R1208JP4OC/R1208JP4TC:</p> <ul style="list-style-type: none"> ▪ One Mini SAS connector to backplane to support 4-port SATA/SAS 3 Gb/sec. ▪ Four ports on motherboard to backplane to support SATA/SAS 3Gb/sec. ▪ Intel® ESRT2 SAS/SATA RAID 0,1,5,10, or Intel® RSTe SATA RAID 0,1,5, and 10. |

| Feature | Description |
|----------------------------------|--|
| | <ul style="list-style-type: none"> ▪ Intel® RAID C600 Upgrade Key support providing optional expanded SATA/SAS RAID capabilities. |
| Server Management | <ul style="list-style-type: none"> ▪ Onboard ServerEngines* LLC Pilot III* Controller. ▪ Support for Intel® Remote Management Module 4 Lite solutions. ▪ Intel® Light-Guided Diagnostics on field replaceable units. ▪ Support for Intel® System Management Software. ▪ Support for Intel® Intelligent Power Node Manager (need PMBus*-compliant power supply). |
| Power Supply Options | <ul style="list-style-type: none"> ▪ 750W AC Power Supply, 80 plus Platinum with PFC configuration. Chassis SKU: R1304JP4GS/R1208JP4GS. ▪ 450W ACRedundant Power Support, 80 plus platinum with PFC. Chassis SKU: R1304JP4OC/R1208JP4OC. ▪ 450W DCRedundant Power Support, 80 plus platinum with PFC. Chassis SKU: R1304JP4TC/R1208JP4TC. |
| Storage Bay Options | <ul style="list-style-type: none"> ▪ 4x 3.5-inch SATA/SAS HDD bays (SKU: R1304JP4 serial). ▪ 8x 2.5-inch SATA/SAS HDD bays (SKU: R1208JP4 serial). ▪ One optical drive bay (SKU: R1304JP4 serial) |
| Available Rack Mount Kit Options | <ul style="list-style-type: none"> ▪ Slide rail kit (AXXELVRAIL), bundled with system package. |

Server System Components

This section helps you identify the components of your server system. If you are near the system, you can also use the *Quick Reference Label* provided on the inside of the chassis cover to assist in identifying components.

The R1000JP family has four compute nodes in the chassis. The whole system view is as below (with top cover removed).

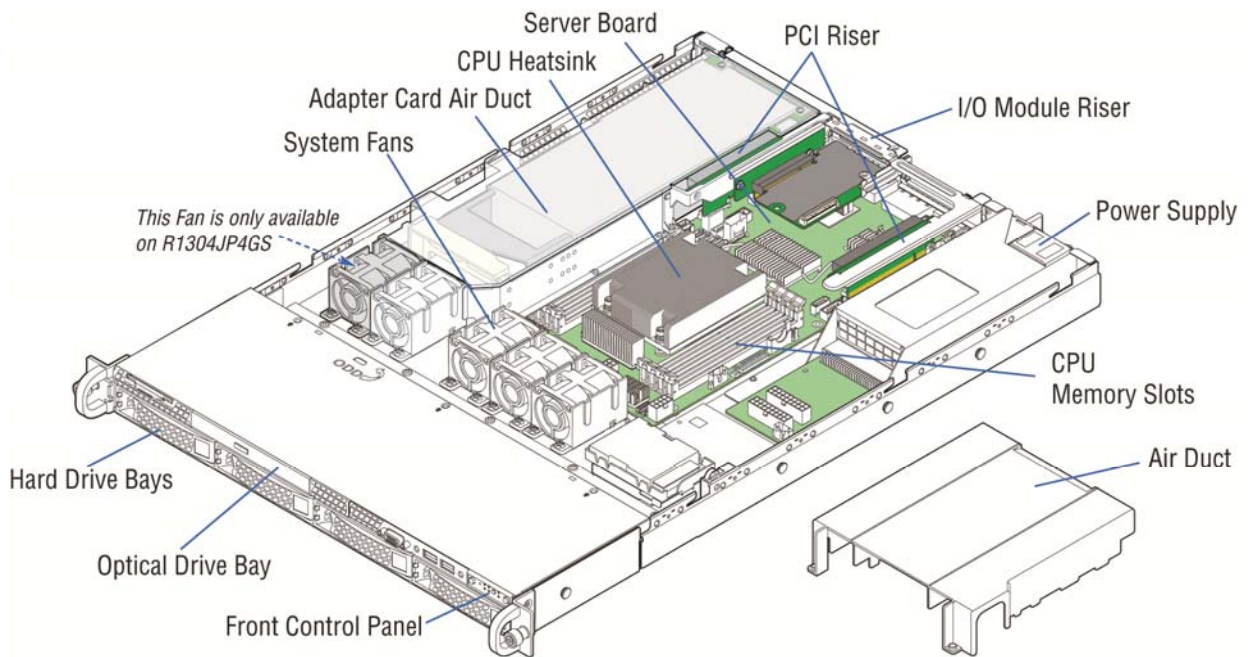

AF005613

Figure 2. Intel® Server System R1000JP Overview R1304JP4GS as demonstrated)

There are two configurations of hard disk drives for R1000JP family.

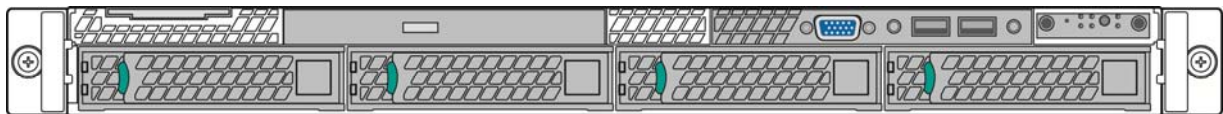

AF004121

Figure 3. Front View of Intel® Server System R1304JP4 with 4x3.5" HDD bays

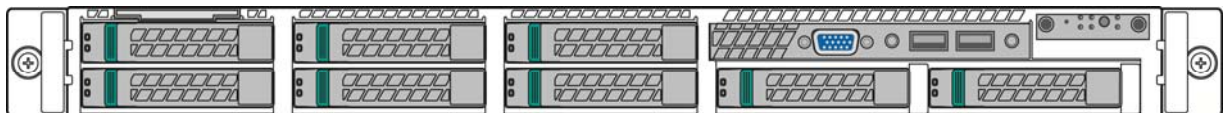

AF004120

Figure 4. Front View of Intel® Server System R1208JP4 with 8x2.5" HDD bays

Front Panel

The system contains one control panel.

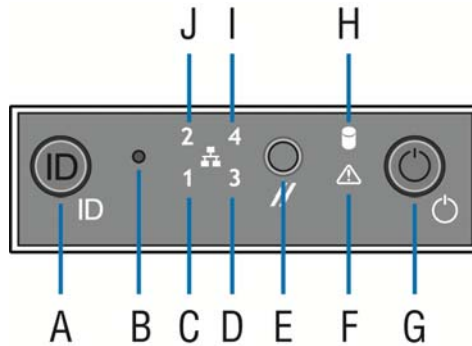

AF004065

| Label | Description | Label | Description |
|-------|--|-------|-------------------------------|
| A | System ID Button w/Integrated LED | F | System Status LED |
| B | NMI Button (recessed, tool required for use) | G | Power Button w/Integrated LED |
| C | NIC-1 Activity LED | H | Hard Drive Activity LED |
| D | NIC-3 Activity LED | I | NIC-4 Activity LED |
| E | System Cold Reset Button | J | NIC-2 Activity LED |

Figure 5. Front View of Intel® Server System R1208JP4 with 8x2.5" HDD bays

Back Panel

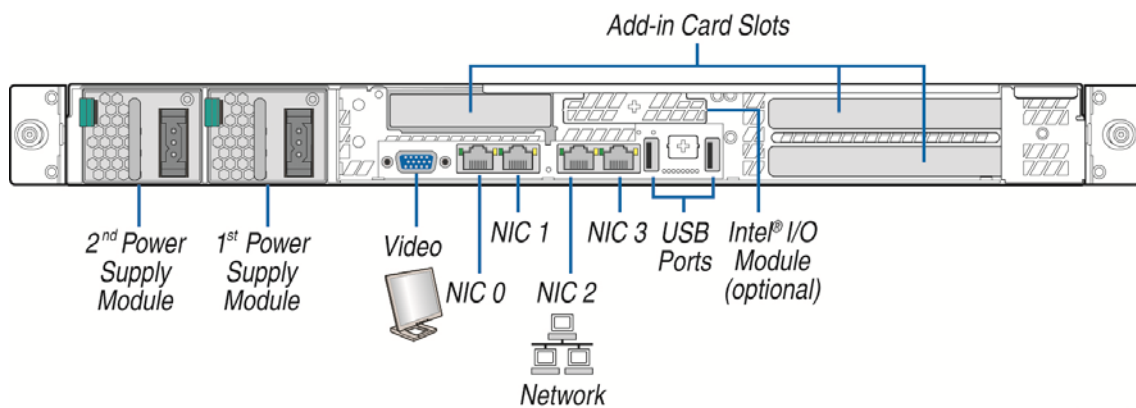

AF005646

Figure 6. Back Panel Feature Identification

Server Board Components

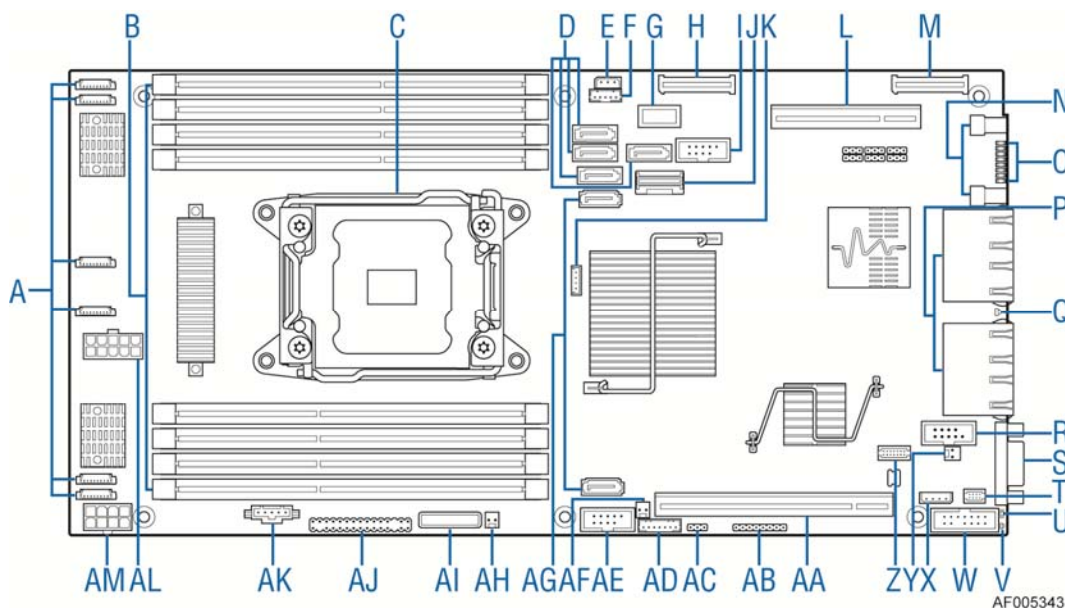

AF005343

| | | | | | | | |
|---|-----------------------|---|------------------------|----|--------------------------|----|-----------------------|
| A | 6 system fans | K | Storage upgrade key | U | 5V standby LED | AE | Internal USB |
| B | 8 DIMM sockets | L | Riser slot 2 | V | ID LED | AF | HDD LED Header |
| C | CPU socket | M | Riser Slot 3A | W | Internal Video connector | AG | Two 6Gbps SATA ports |
| D | Four 3Gbps SATA ports | N | Two external rear USBs | X | IPMB | AH | HDD LED |
| E | HSBP I ² C | O | Diagnostic LED | Y | Chassis intrusion | AI | Battery |
| F | SGPIO | P | 4 NIC 1Gbe ports | Z | TPM connector | AJ | Front panel connector |
| G | TypeA USB | Q | System status LED | AA | Riser slot 1 | AK | PMBus* |
| H | Riser Slot 3B | R | Internal Serial port | AB | JPLD TAG | AL | 5x2 Main power 1 |
| I | Internal USB | S | Video port | AC | PECI | AM | 4x2 Main power 2 |
| J | Mini SAS port | T | RMM4 lite | AD | LCP | | |

Figure 7. Server Board S1600JP4 Connector and Component Locations

Intel® Light-Guided Diagnostics

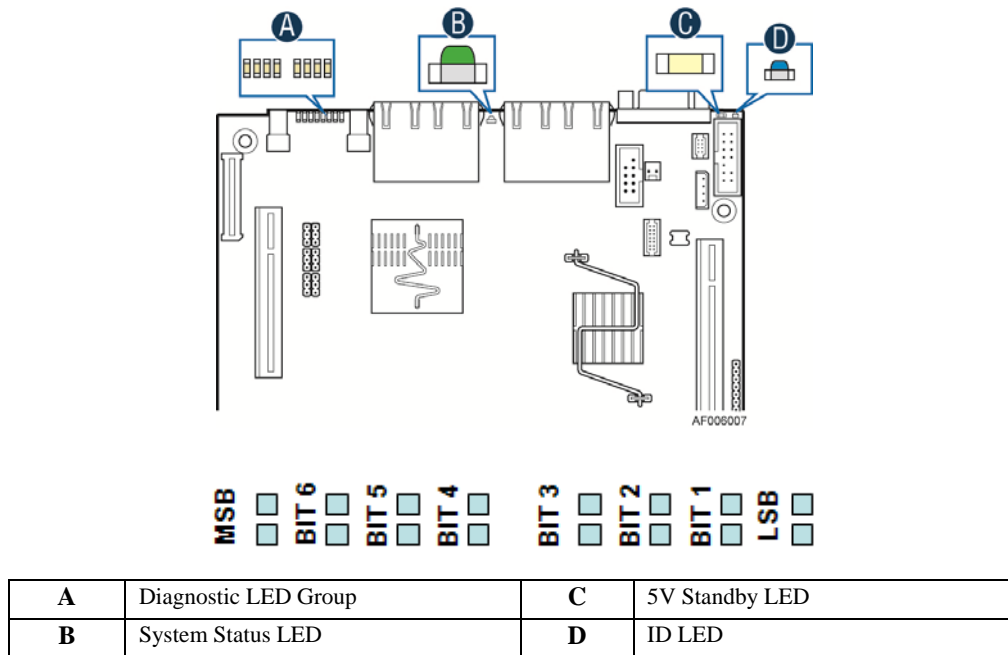
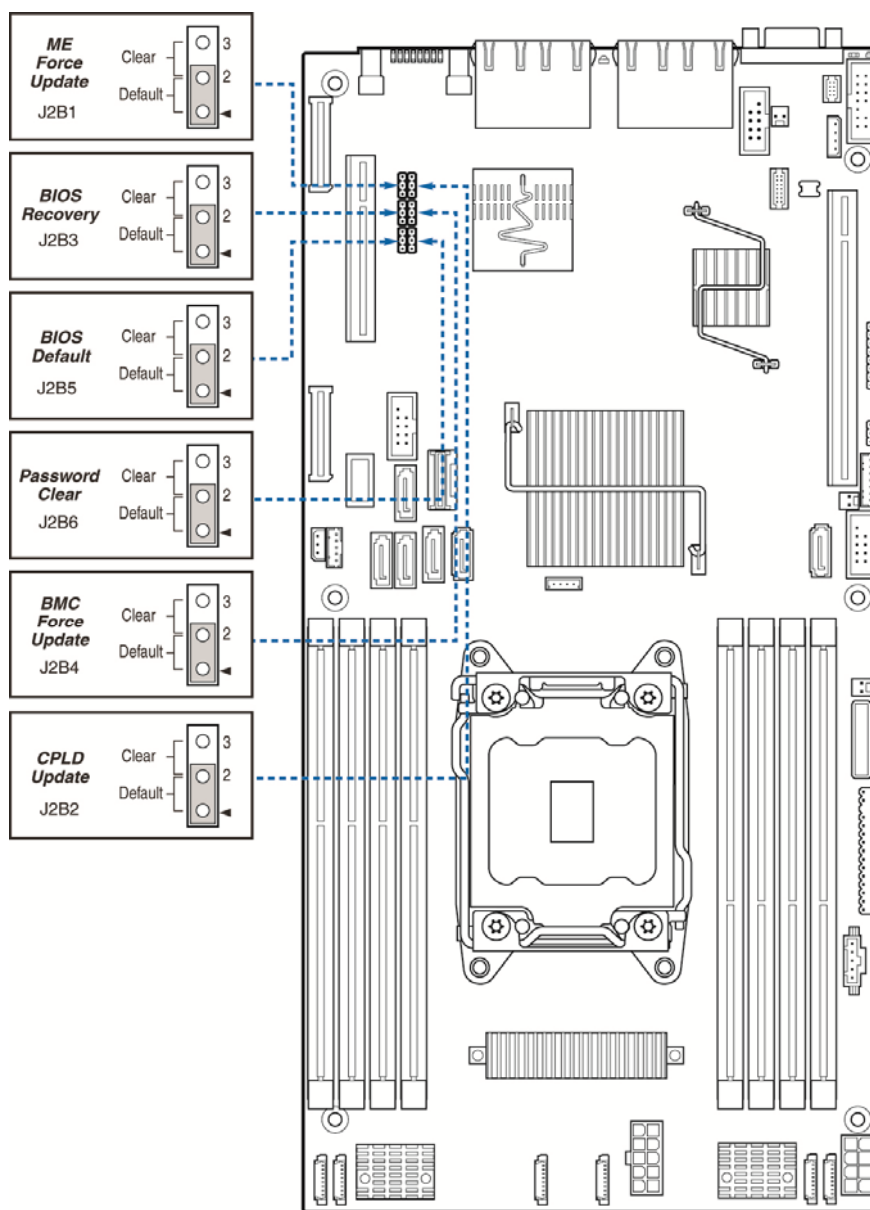

Figure 8. Intel® Light-Guided Diagnostic LEDs - Server Board

The server system contains the following diagnostic LEDs, each providing the following functions:

1. Section A – POST Code Diagnostic LEDs on the server board change color or state (off, green, red, and amber) according to the POST sequence.
2. Section B – The System Status LED on the front and back panels shows the overall health of the system (green, blinking green, blinking amber, amber, off).
3. Section C – 5V Stand By LEDs
4. Section D –The System Identification LED on the front and back panel helps identify the server from among several servers. The ID LED is off by default, and blue when activated by button or software.

System Jumpers



AF005491

| Jumper Name | Jumper Position | Mode of Operation | Note |
|-------------------------------|-----------------|-------------------|-------------------------------------|
| J2B1: ME Force Update | 1-2 | Normal | Normal mode |
| | 2-3 | Update | ME in force update mode |
| J2B4: BMC Force Update jumper | 1-2 | Normal | Normal mode |
| | 2-3 | Update | BMC in force update mode |
| J2B6: Password Clear | 1-2 | Normal | Normal mode, password in protection |
| | 2-3 | Clear Password | BIOS password is cleared |
| J2B3: BIOS Recovery Mode | 1-2 | Normal | Normal mode |
| | 2-3 | Recovery | BIOS in recovery mode |
| J2B2: CPLD Update | 1-2 | Normal | Normal mode |

| Jumper Name | Jumper Position | Mode of Operation | Note |
|--------------------|-----------------|---------------------|--|
| | 2-3 | Update | |
| J2B5: BIOS Default | 1-2 | Normal | Normal mode |
| | 2-3 | Clear BIOS Settings | BIOS settings are reset to factory default |

Figure 9. Configuration Jumpers

Hard Disk Drive Carriers

The Intel® Server System R1000JP ships in two different basic SKUs, and with different maximum number of hard disk drives, see below table for details:

Table 4. Hard Disk Drive Options

| Intel® Server System | Supported Hard Drive Type | Maximum Hard Drive Number |
|----------------------------------|---------------------------|---------------------------|
| R1304JP4TC/R1304JP4OC/R1304JP4GS | 3.5-inch | 4 |
| R1208JP4TC/R1208JP4OC/R1208JP4GS | 2.5-inch | 8 |

Note: 1. Drives can consume up to 17 watts of power each. Drives must be specified to run at a maximum ambient temperature of 45°C.

Bezel

The front bezel is available as optional accessory for the server system:

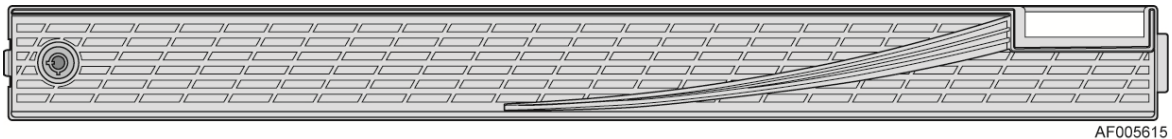

AF005615

Figure 10. Front view of System Bezel

Hot-Swap SAS/SATA Backplane

The Hot-Swap SAS/SATA backplane serves as an interface between the mother board and the system drives. The following diagrams show the location for each connector found on the backplane.

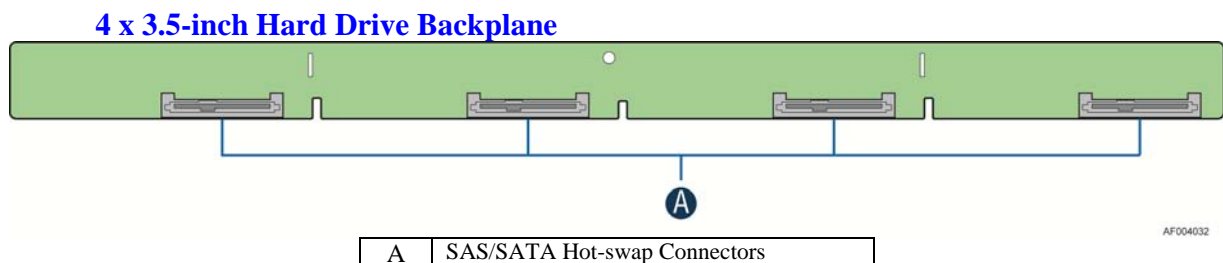

AF004032

Figure 11. 4 x 3.5-inch Hard Drive Backplane Components (Front View)

Server System Features

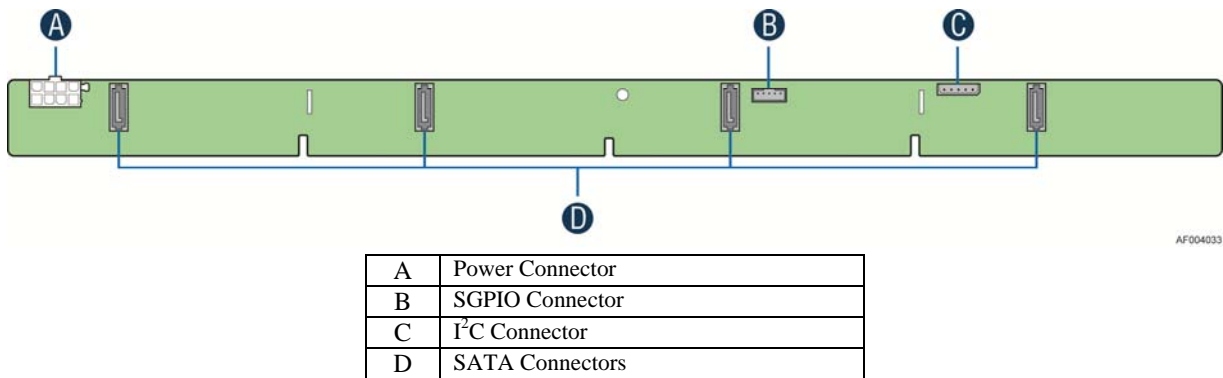

Figure 12. 4 x 3.5-inch Hard Drive Backplane Components (Rear View)

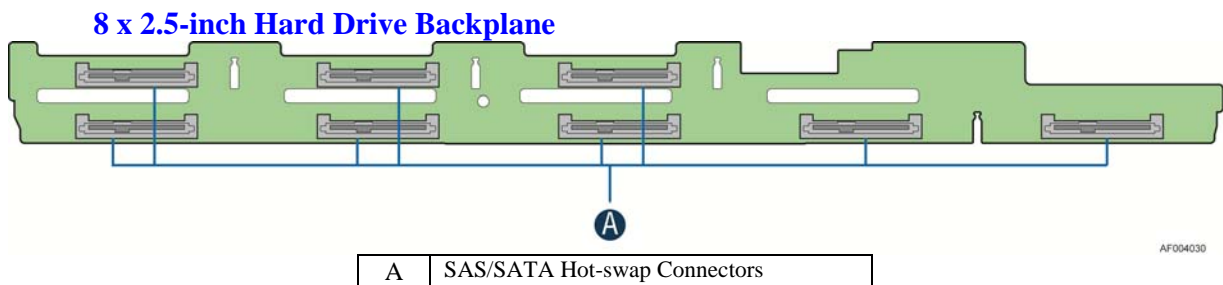

Figure 13. 8 x 2.5-inch Hard Drive Backplane Components (Front View)

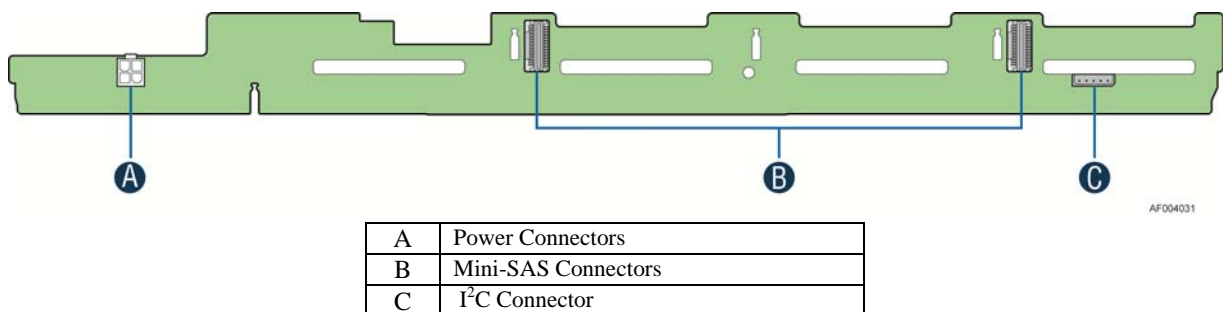

Figure 14. 8 x 2.5-inch Hard Drive Backplane Components (Rear View)

Advanced Management Options

Intel[®] Remote Management Module 4 Lite

The Intel[®] Remote Management Module 4 Lite plugs into a dedicated connector on the server board and provides additional server management functionality to the Compute Node.

This module, together with dedicated management port on IOM carrier sitting on Slot2 riser provides a dedicated web server for viewing server information and remote control of the system.

It also provides Remote KVM Redirection and USB Media Redirection allowing USB devices attached to the remote system to be used on the managed server.

For instructions on installing the Intel® Remote Management Module 4 Lite, see [Installing the Intel® RMM4 Lite](#)

2 Hardware Installations and Upgrades

Before You Begin

Before working with your server product, pay close attention to the [Safety Information on page iii](#) at the beginning of this manual.

***Note:** Whenever you service the system, you must first power down the server and unplug all peripheral devices and the AC power cord.*

Tools and Supplies Needed

- Phillips* (cross head) screwdriver (#1 bit and #2 bit)
- Needle nosed pliers
- Anti-static wrist strap and conductive foam pad (recommended)

System Reference

All references to left, right, front, top, and bottom assume the reader is facing the front of the chassis as it would be positioned for normal operation.

***Note:** The Intel® Server System R1000JP is shown for illustration purposes; server components with the product family are identical.*

Cable Routing

The Intel® Server System R1000JP family is a high density system. There are a few cables for chassis internal routing.

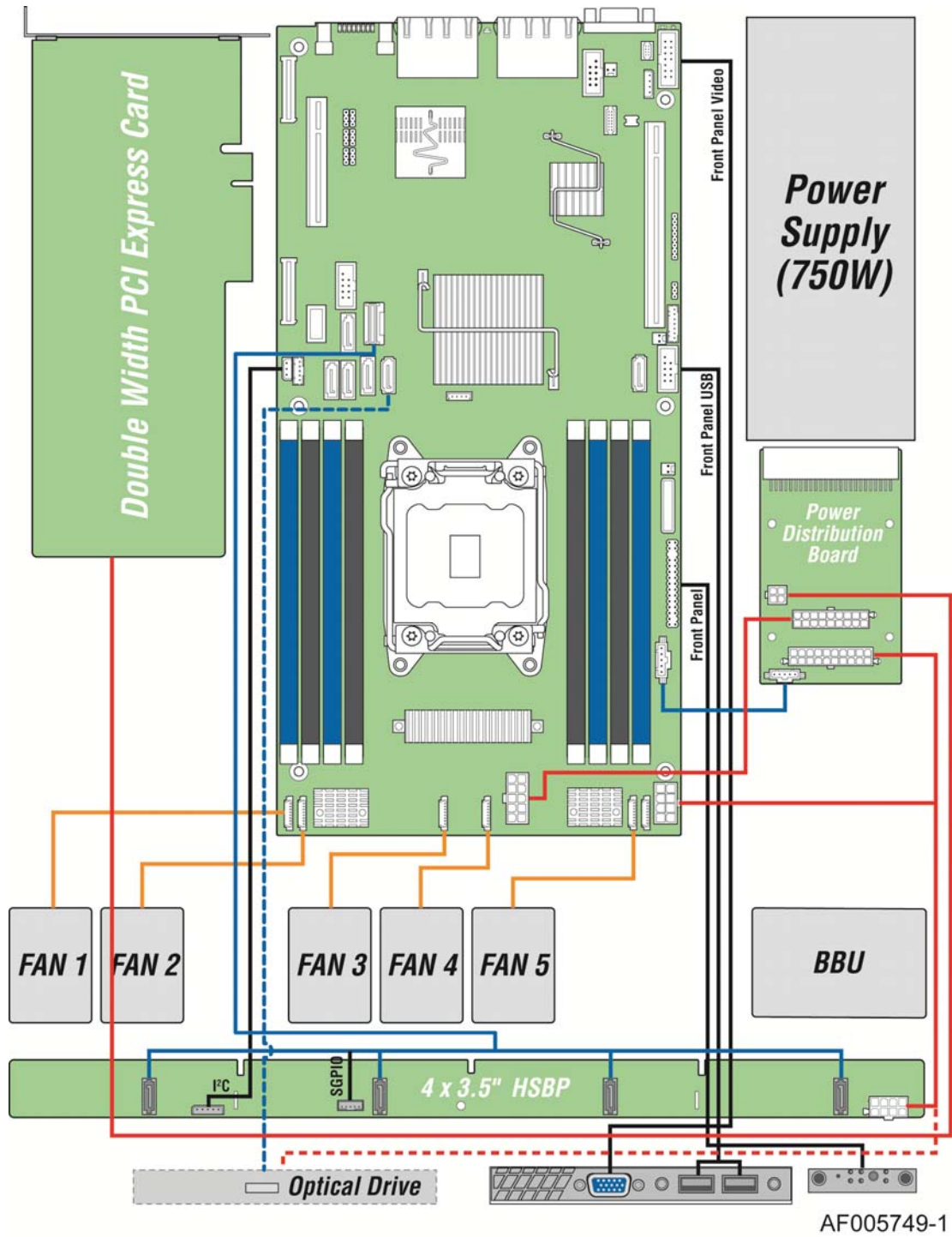
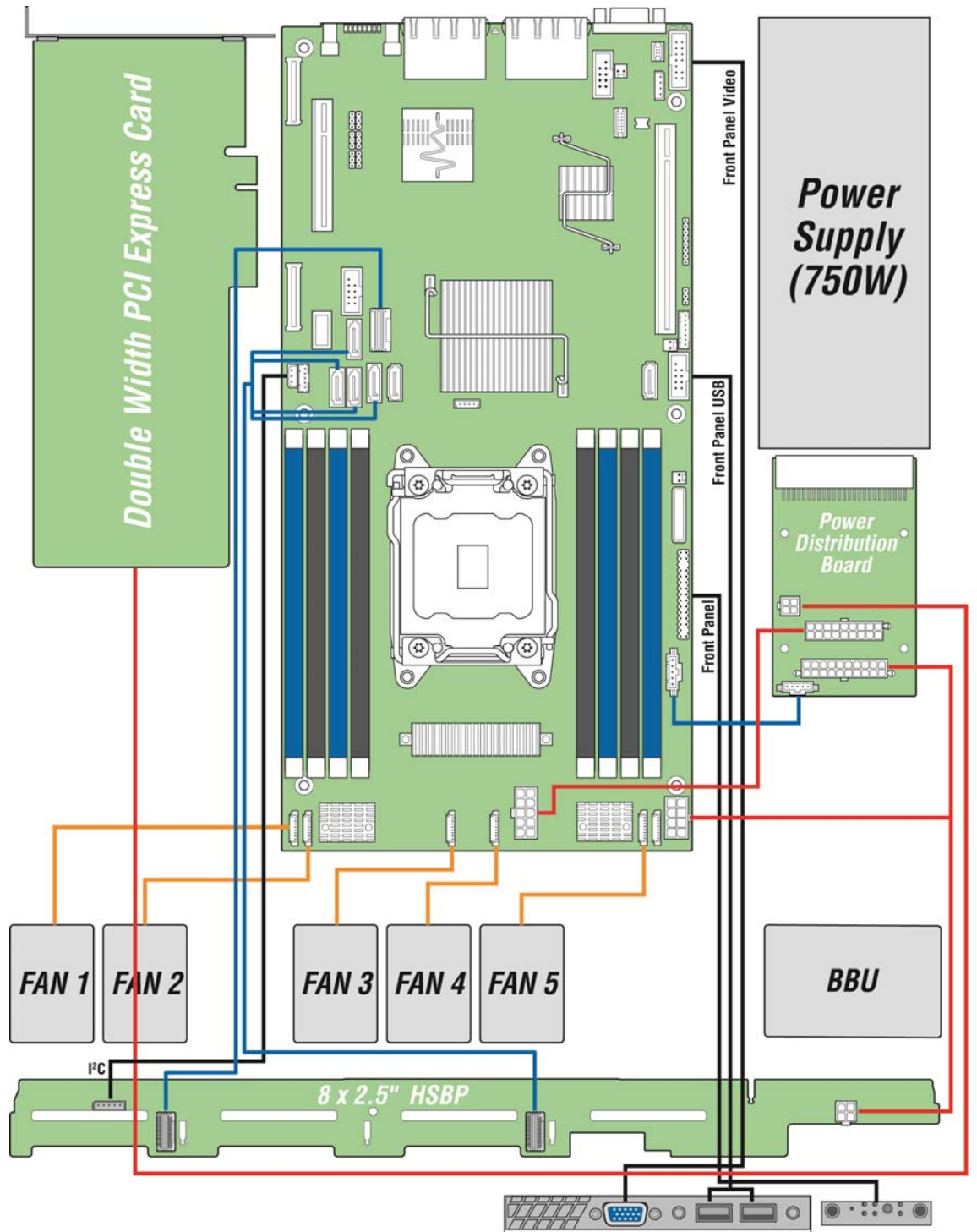

Figure 15. Cable Routing for R1304JP4GS

AF005749-1



AF005750-1

Figure 16. Cable Routing for R1208JP4GS

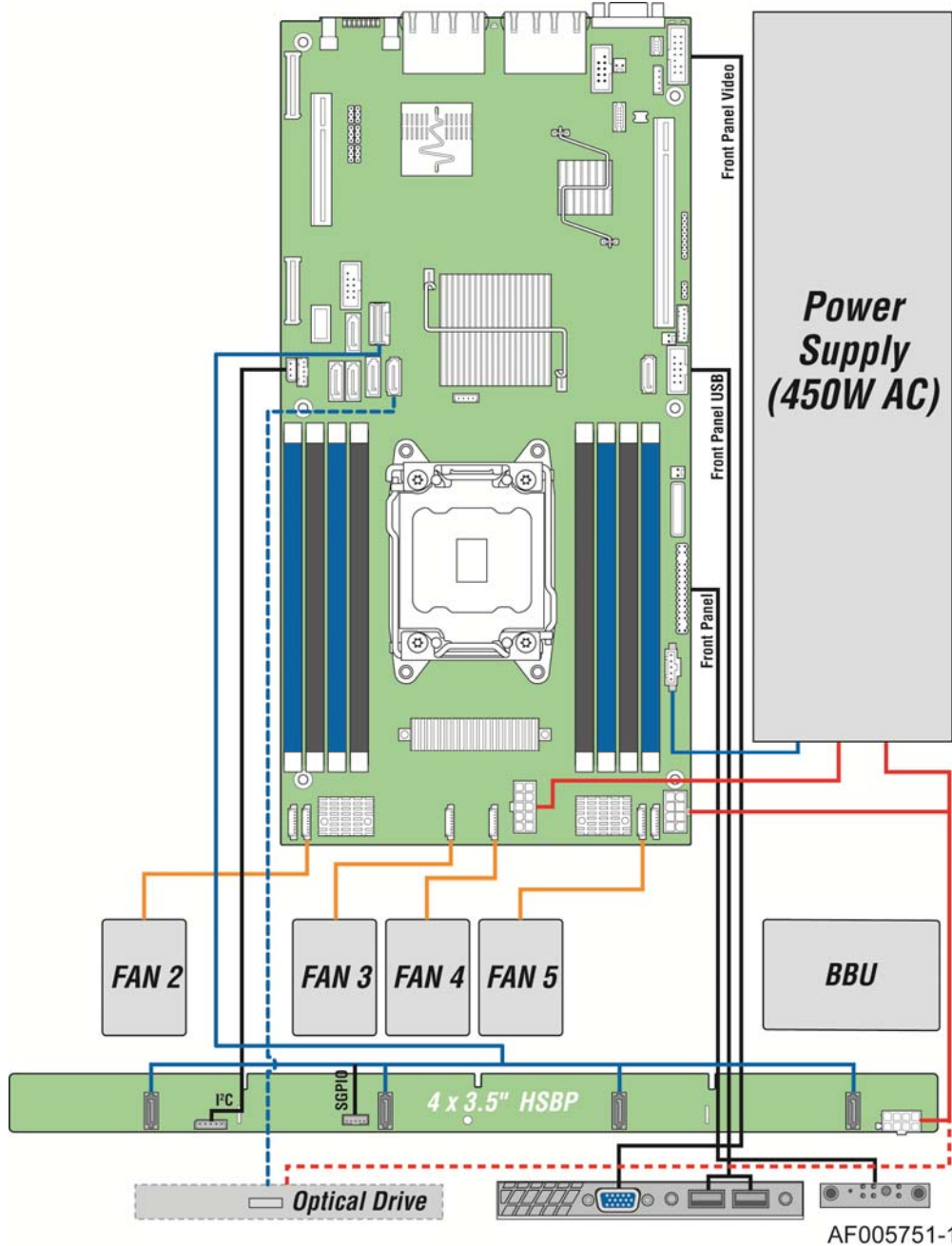

Figure 17. Cable Routing for R1304JP4OC

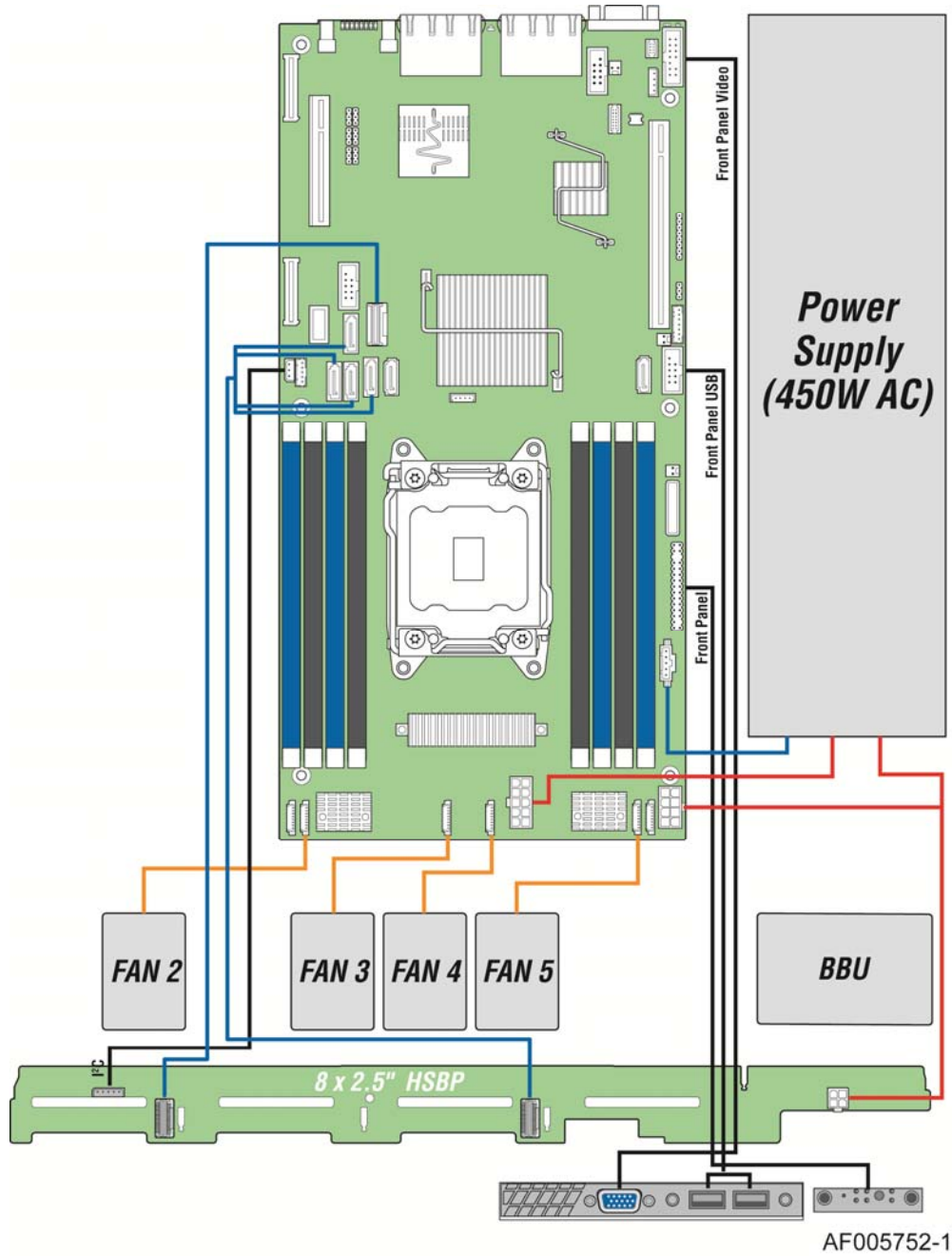

Figure 18. Cable Routing for R1208JP4OC

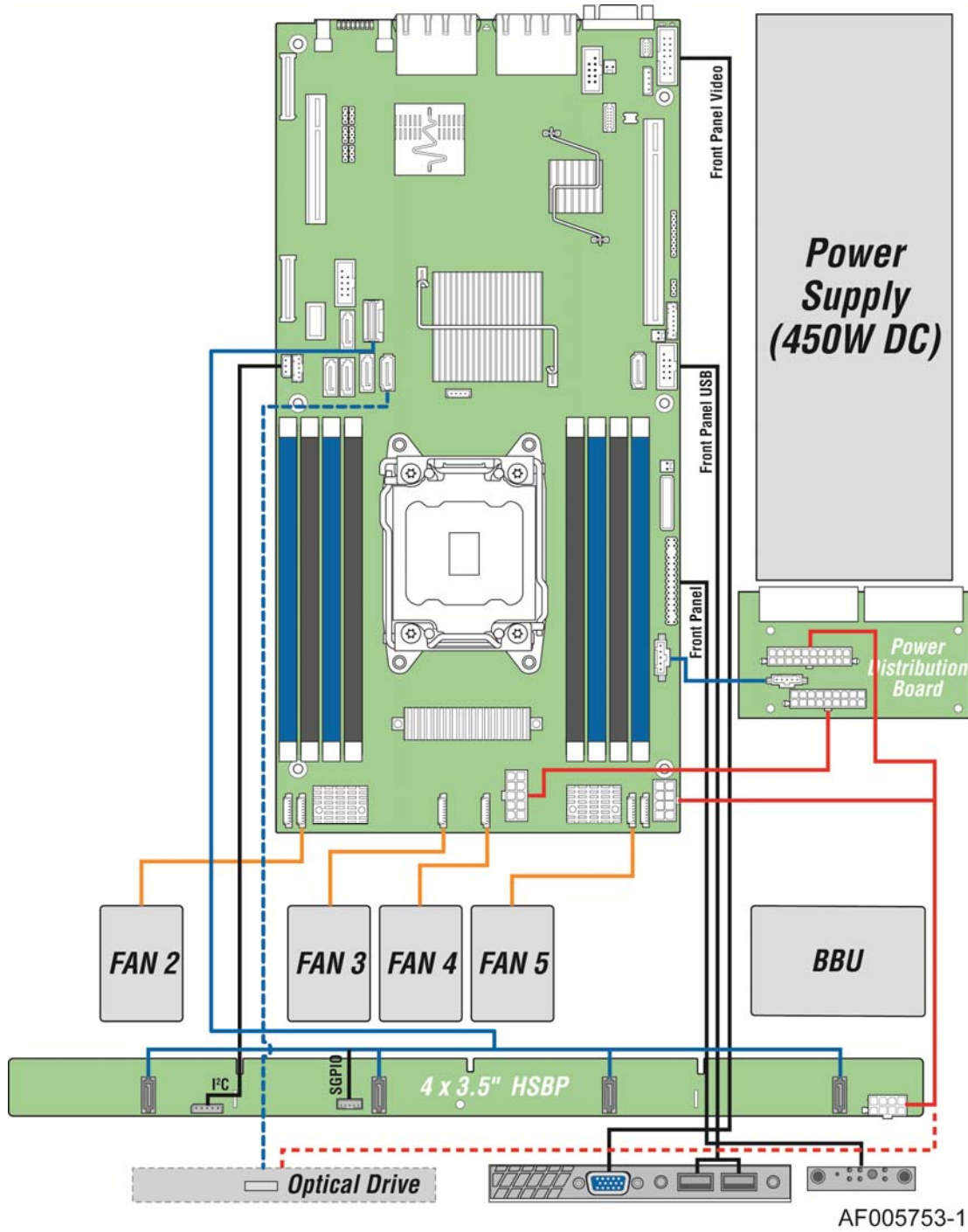

Figure 19. Cable Routing for R1304JP4TC

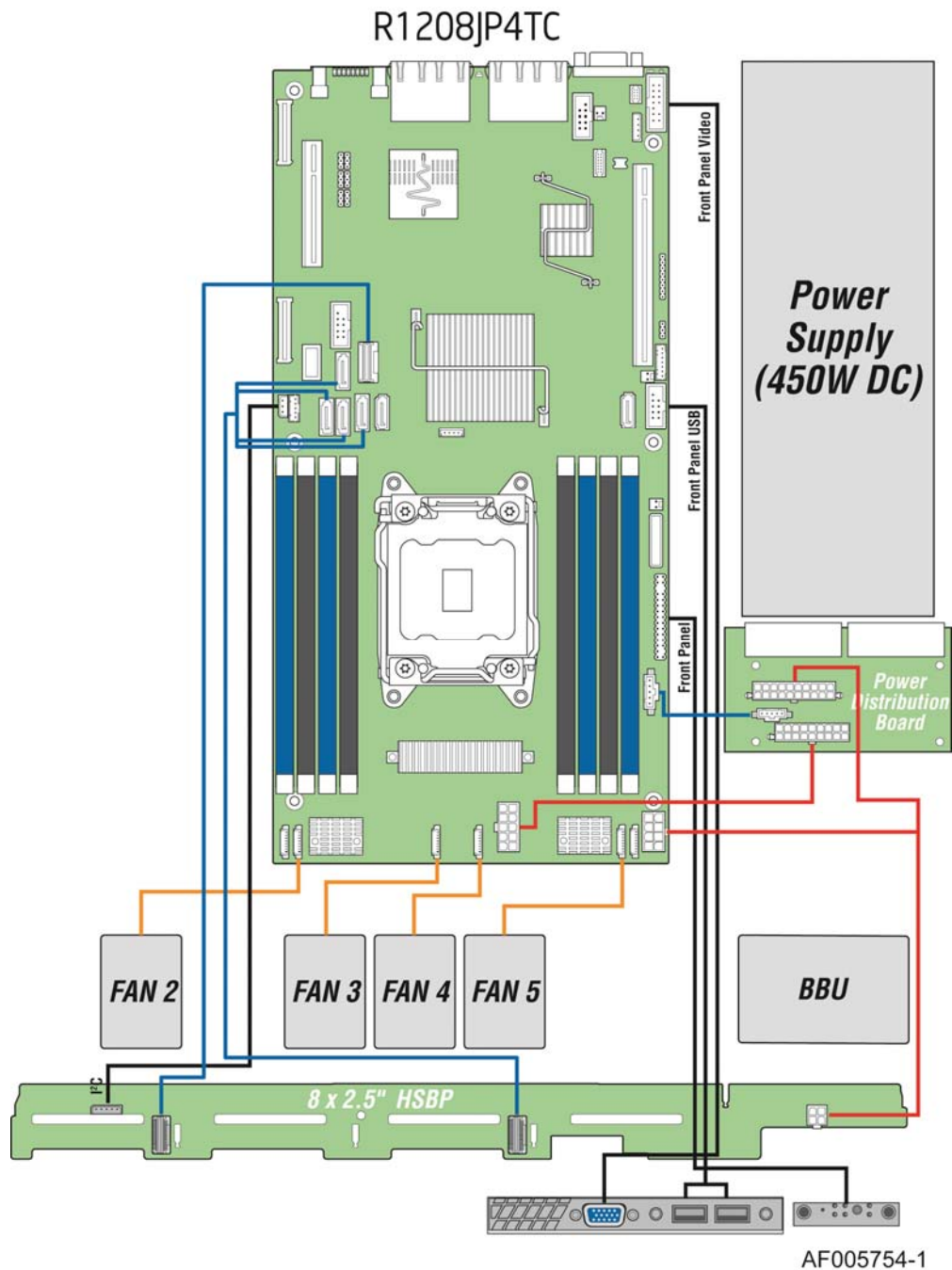

Figure 20. Cable Routing for R1208JP4TC

Removing and Installing the Front Bezel

Removing the Front Bezel

If your system includes a front bezel, follow these steps to remove the front bezel:

1. Unlock the bezel if it is locked.

2. Remove the left end of the front bezel from the rack handle (see letter **A**).
3. Rotate the front bezel anticlockwise to release the latches on the right end from the rack handle (see letter **B**).

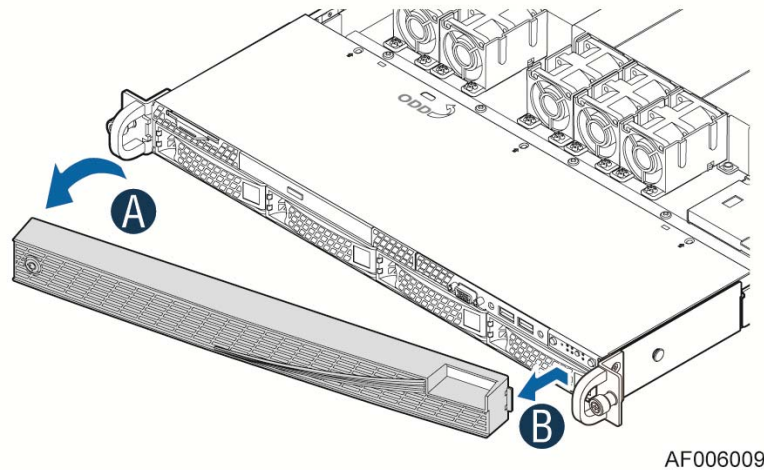

Figure 21. Removing the Front Bezel

Installing the Front Bezel

Note: Before installing the bezel, you must install the rack handles.

1. Lock the right end of the front bezel to the rack handle (see letter **A**).
2. Rotate the front bezel clockwise till the left end clicks into place (see letter **B**).
3. Lock the bezel if needed.

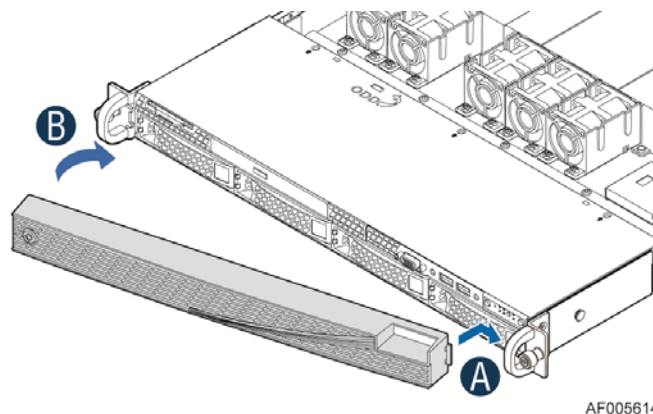

Figure 22. Installing the Front Bezel

Removing and Installing the System Top Cover

Removing the System Top Cover

The server system must be operated with the system cover in place to ensure proper cooling. You will need to remove the top cover to add or replace components (backplane, main power cables, power distribution board) inside of the server. Before removing the top cover, power down the server and

Hardware Installations and Upgrades

unplug all peripheral devices and the power cable(s).

Note: A non-skid surface or a stop behind the server system may be needed to prevent the server system from sliding on your work surface.

1. Observe the safety and ESD precautions at the beginning of this book.
2. Turn off all peripheral devices connected to the server. Turn off the server.
3. Disconnect the power cord.
4. Remove the screws (see letter **A**).
5. Slide cover back and lift upward (see letter **B**).

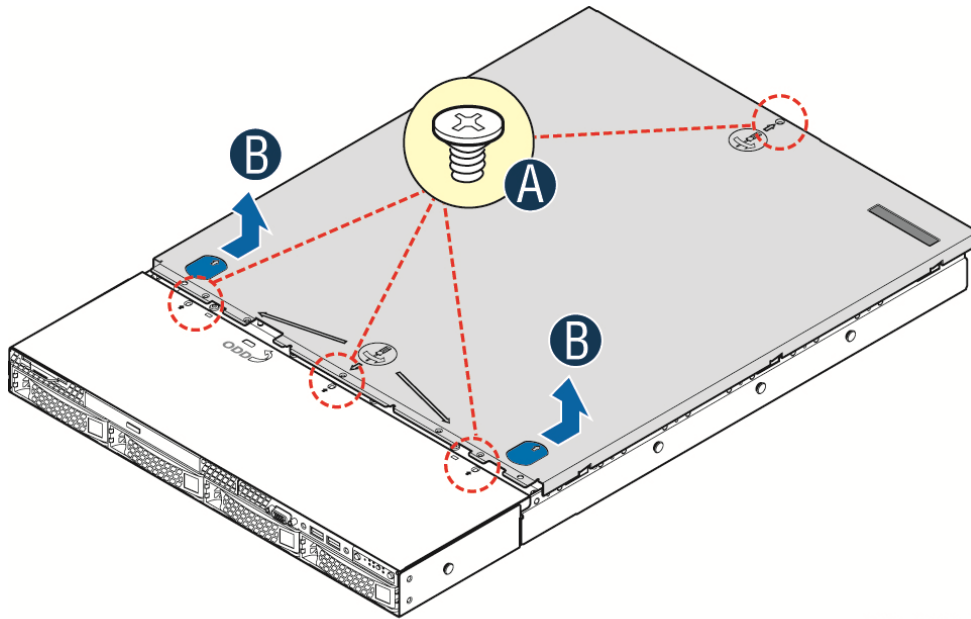

AF005720

Figure 23. Removing the System Top Cover

Installing the System Cover

1. Place the top cover on the system and slide it towards the front of chassis until the recessed front edge is fully engaged. (see letter **A**).
2. Install the three screws at the front and torque to 7-9in-lbs, then install the screw at the back and torque to 7-9in-lbs. (see letter **B**).

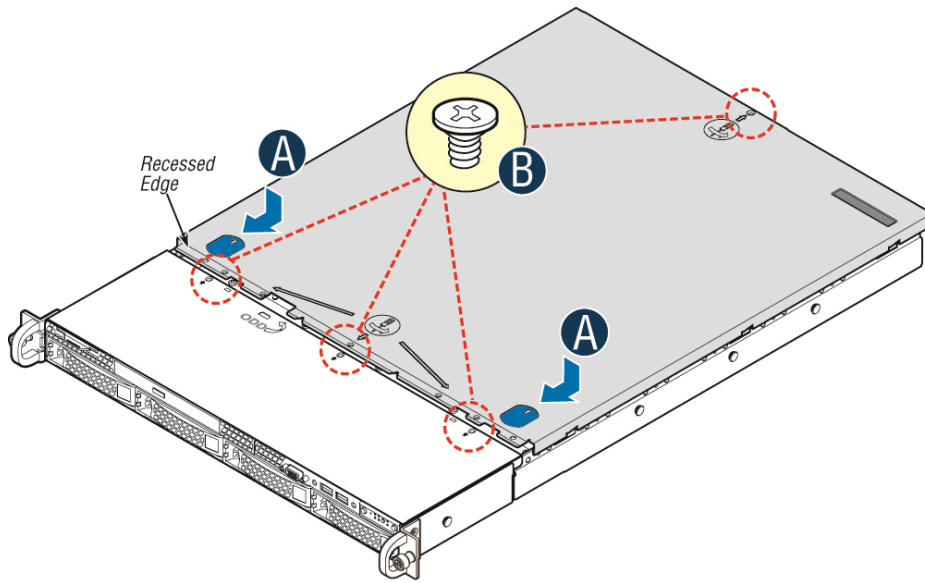

AF005740

Figure 24. Installing the System Cover

Fan Connections

Use the figures below to determine the proper fan connections.

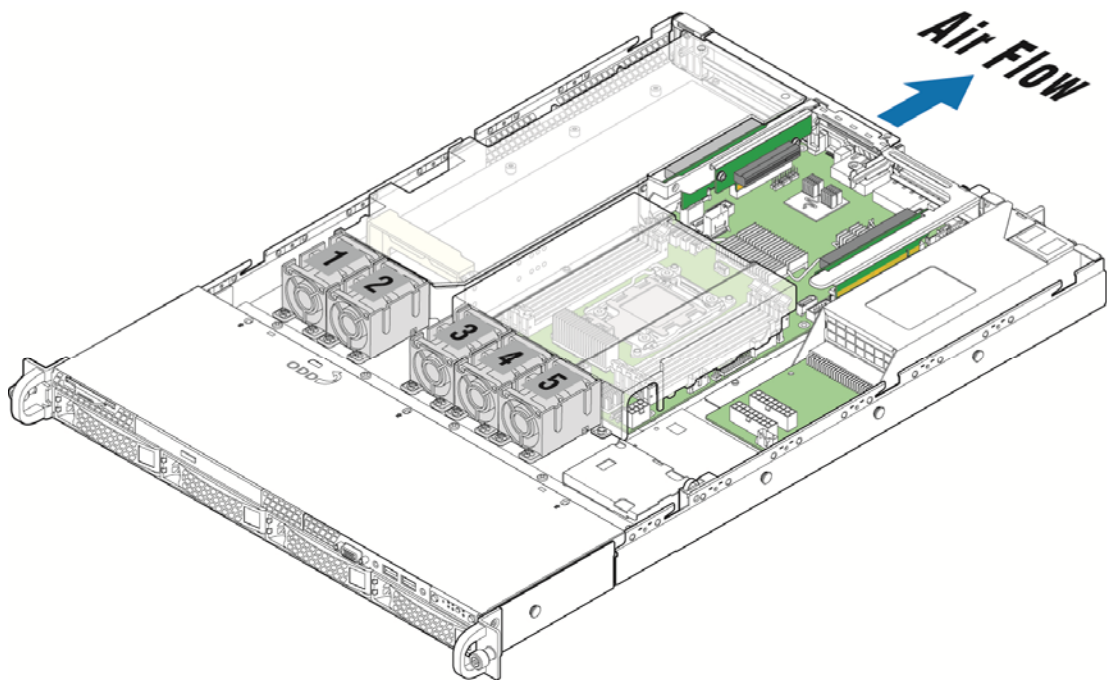

AF005616-1

Figure 25. System Fan Order (R1304JP4GS as showed)

Hardware Installations and Upgrades

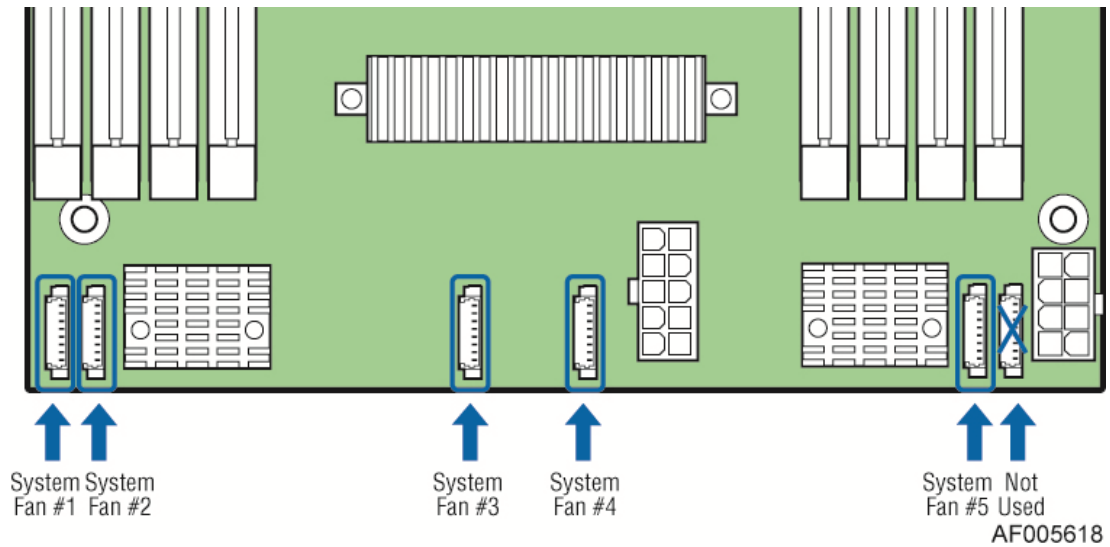

Figure 26. Connecting the Fan Power Cables to the Mother Board

Always Intel® Server System R1304JP4OC, R1208JP4OC, R1304JP4TC, and R1208JP4TC have four fans from FAN1 to FAN4. Intel® Server System R1304JP4GS and R1208JP4GS have five fans from FAN1 to FAN5 as shown.

Removing and Installing the Air Duct

Always operate your server system with the air duct in place. The air duct is required for proper airflow within the server system.

Removing the Air Duct

Remove the air duct by lifting straight up.

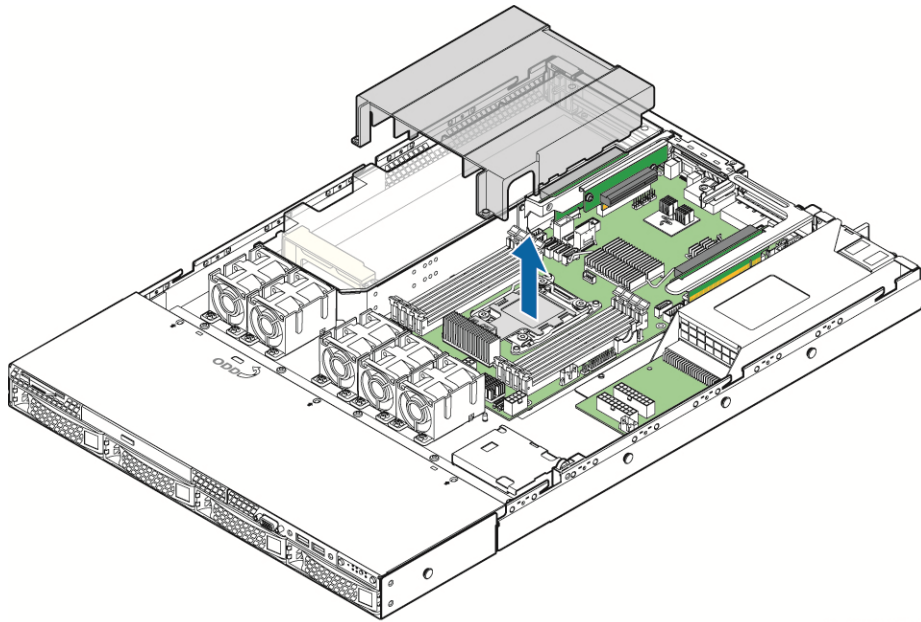

AF005612-1

Figure 27. Removing the Air Duct

Installing the Air Duct

Align the two holes on the air duct with the alignment pins on the chassis and install the air duct into place.

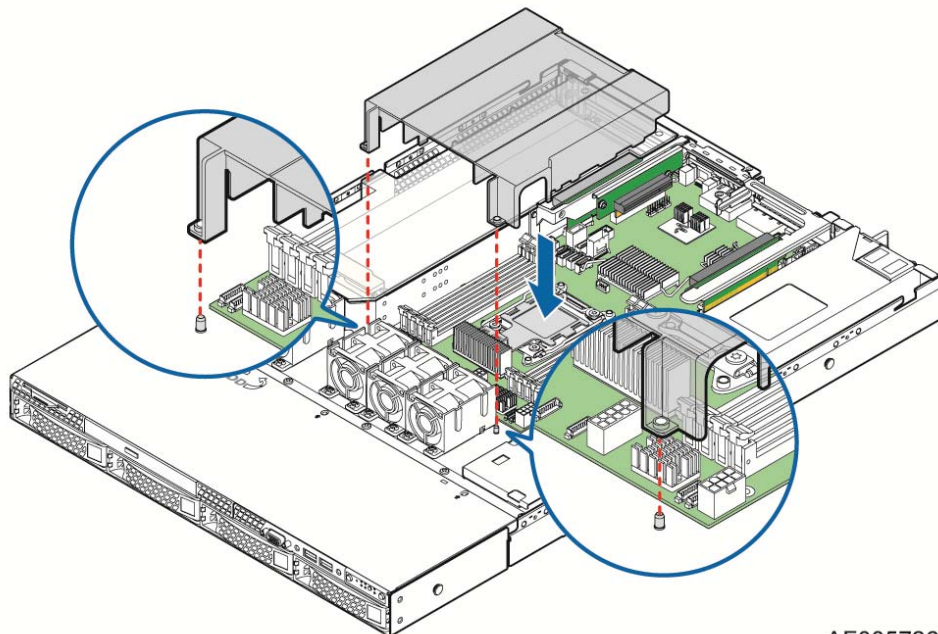

AF005726-1

Figure 28. Installing the Air Duct

Removing and Installing Processor

The heatsink has thermal interface material (TIM) on the underside of it. Use caution so that you do not damage the thermal interface material. Use gloves to avoid sharp edges.

Removing Processor Heatsink

The heatsink is attached to the server board/processor socket with captive fasteners. Using a #2 Phillips* screwdriver, loosen the four screws located on the heatsink corners in a diagonal manner using the following procedure:

1. Using a #2 Phillips* screwdriver, start with screw 1 and loosen it by giving it two rotations and stop (see letter **A**). (IMPORTANT: Do not fully loosen.)
2. Proceed to screw 2 and loosen it by giving it two rotations and stop (see letter **B**). Similarly, loosen screws 3 and 4. Repeat steps A and B by giving each screw two rotations each time until all screws are loosened.
3. Lift the heatsink straight up (see letter **C**).

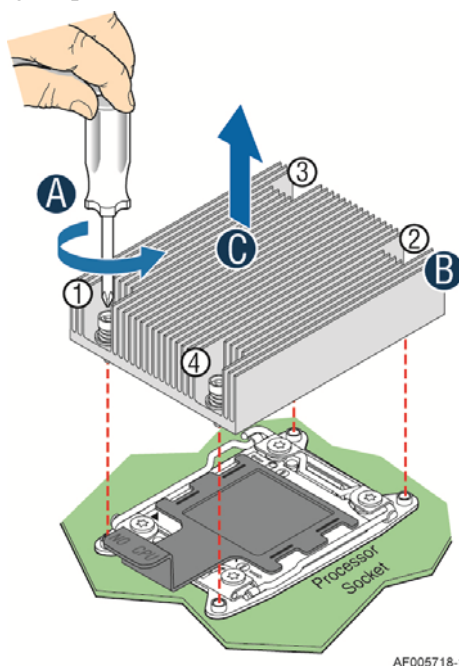

Figure 29. Removing the heatsink

Installing the Processor

Caution 1: *The processor must be appropriate: You may damage the server board if you install a processor that is inappropriate for your server. For a web link to the list of compatible processor(s), see “Additional Information and Software” on page 4.*

Caution 2: *ESD and handling processors: Reduce the risk of electrostatic discharge (ESD) damage to the processor by doing the following:*

1. *Touch the metal chassis before touching the processor or server board. Keep part of your body in contact with the metal chassis to dissipate the static charge while handling the processor.*

2. Avoid moving around unnecessarily.

Caution 3: Protective socket cover needs to be removed for proper cooling of the processor; failure to remove the cover could result in damage to the system.

1. Open the Socket Lever. Push the level handle down and away from the socket to release it (see letter **A**). Rotate the lever open all the way (see letter **B**).

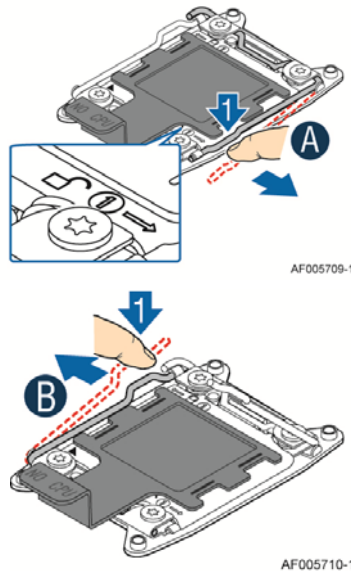

Figure 30. Installing Processor – Open the Socket Lever

2. Open the Load Plate. Press the locking lever slightly to raise the load plate (see letter **A**). Open the load plate all the way (see letter **B**).

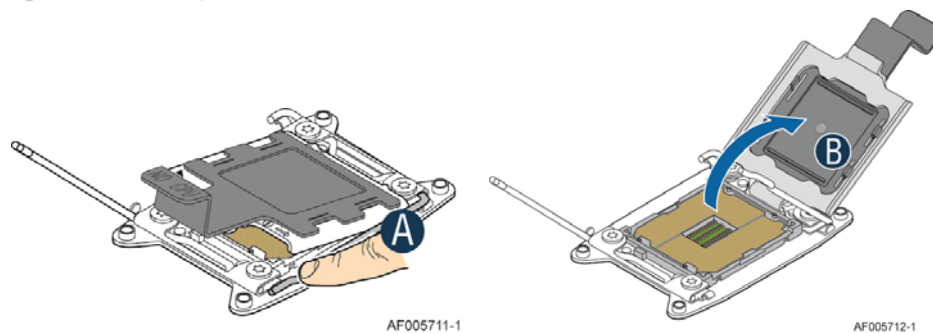

Figure 31. Installing Processor – Open the Load Plate

3. Install the Processor. Take the processor out of the box and remove the protective shipping cover. Orient the processor with the socket, so that the orientation notches on the processor align with the two orientation posts on the socket (see letter **B** and **C**).

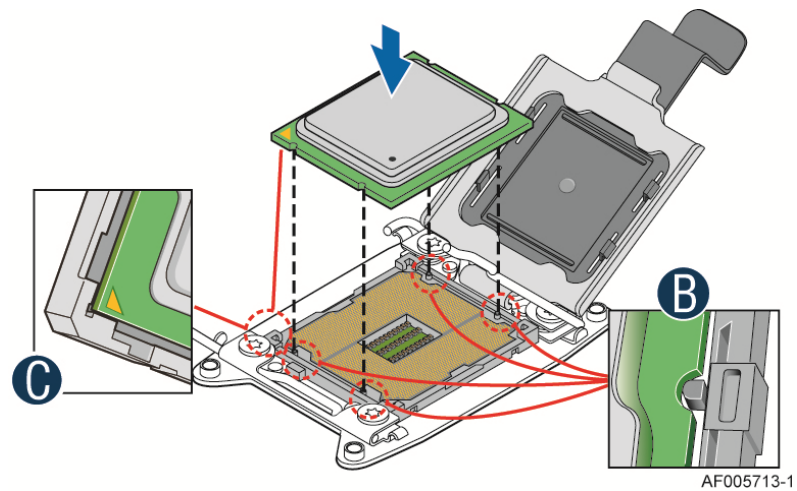

Figure 32. Installing Processor – Install the Processor

Note: The underside of the processor has components that may damage the socket pins if installed improperly. Processor must align correctly with the socket opening before installation. **DO NOT DROP** the processor into the socket!

4. Press the protective cover to remove it from the load plate. Close the Load Plate and Socket Lever.

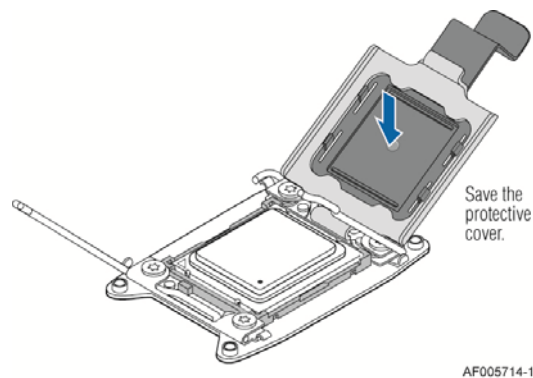

Figure 33. Installing Processor – Remove the Cover

5. Close the load plate all the way as shown.

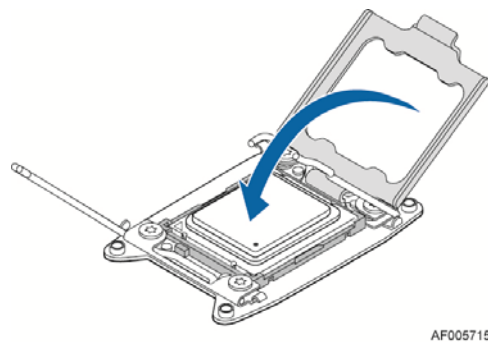

Figure 34. Installing Processor – Close the Load Plate

6. With your finger, push down on the load plate lever as shown. Close the socket lever and ensure that the load plate tab engages under the socket lever when fully closed.

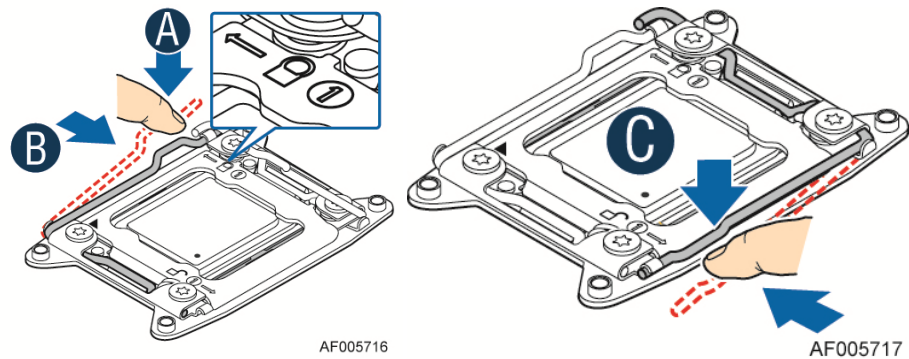

Figure 35. Installing Processor – Latch the Locking Lever

Installing Processor Heatsink(s)

1. Remove the protective film on the TIM if present (see letter **A**).
2. Align heatsink fins to the front and back of the chassis for correct airflow. Airflow goes from front-to-back of chassis (see letter **B**).
3. Each heatsink has four captive fasteners and should be tightened in a diagonal manner using the following procedure:
 - i. Using a #2 Phillips* screwdriver, start with screw 1 and engage screw threads by giving it two rotations and stop (see letter **C**). Do not fully tighten.
 - ii. Proceed to screw 2 and engage screw threads by giving it two rotations and stop (see letter **D**). Similarly, engage screws 3 and 4.
 - iii. Repeat steps C and D by giving each screw two rotations each time until each screw is lightly tightened up to a maximum of 8 inch-lbs torque (see letter **E**).

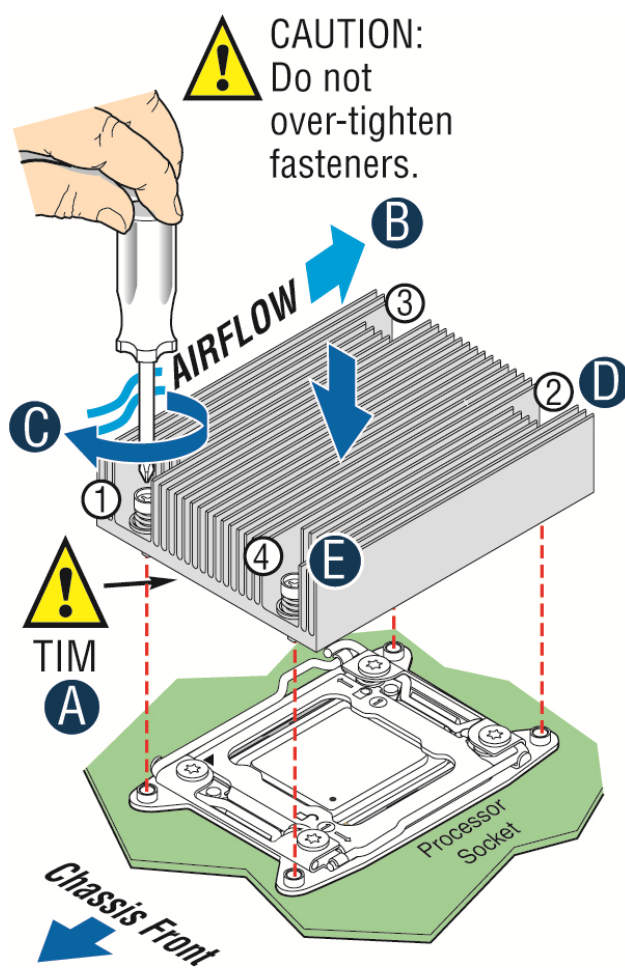

Figure 36. Installing Processor Heatsinks

Installing and Removing Memory

Installing Memory

1. Locate the DIMM sockets. Make sure the clips at either end of the DIMM socket(s) are pushed outward to the open position (see letter **A**).
2. Holding the DIMM by the edges, remove it from its anti-static package. Position the DIMM above the socket. Align the notch on the bottom edge of the DIMM with the key in the DIMM socket (see letter **B**).
3. Insert the bottom edge of the DIMM into the socket (see letter **C**). When the DIMM is inserted, push down on the top edge of the DIMM until the retaining clips snap into place (see letter **D**). Make sure the clips are firmly in place (see letter **E**).

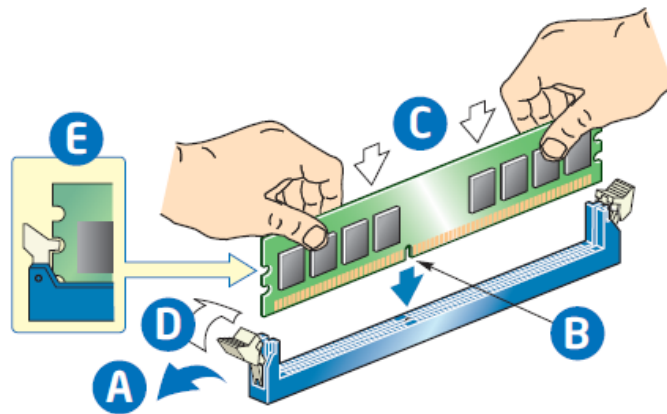

Figure 37. Installing Memory

Removing Memory

1. Locate the DIMM sockets. Gently spread the retaining clips at each end of the socket. The DIMM lifts from the socket.
2. Holding the DIMM by the edges, lift it from the socket, and store it in an anti-static package.

Installing and Removing Hot-swap Hard Drive

Caution: If you do not install all the drives, empty drive bays must be occupied by carriers with plastic drive blank provided to maintain proper system cooling.

Installing a 3.5" Hard Disk Drive into 3.5" Hard Drive Carrier

1. Remove the drive carrier by pressing the green button (letter A) and slide the carrier out (letter B).

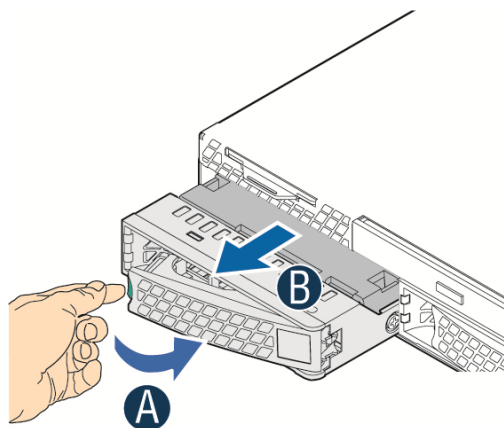

AF004127

Figure 38. Installing Hard Disk Drive – Removing the drive carrier

2. Remove the four screws securing the HDD interface bracket and install 3.5" HDD with screws shown in letter C.

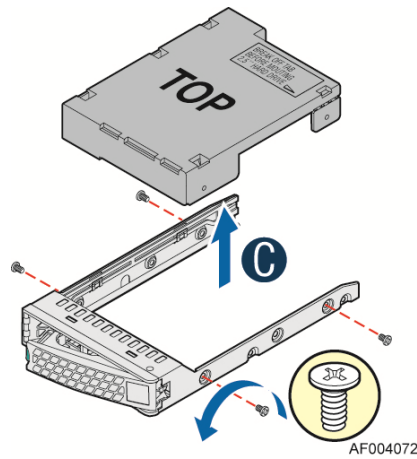

Figure 39. Installing Hard Disk Drive – Removing the screws

3. Install the 3.5" hard disk drive using the same four screws as shown (see letter **D**).

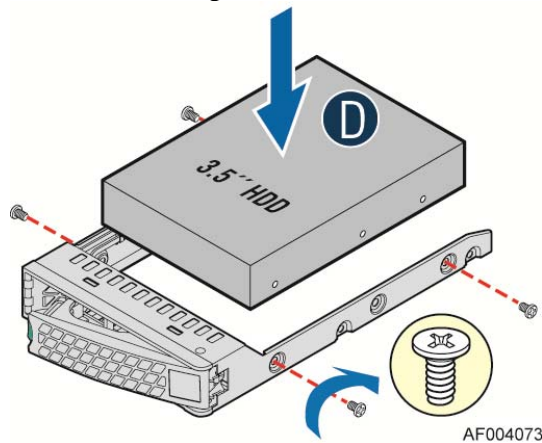

Figure 40. Installing Hard Disk Drive – assembling 3.5" HDD

4. With the lever open, insert the hard disk drive assembly into the chassis (see letter **E**). Push in the lever to lock it into place (see letter **F**).

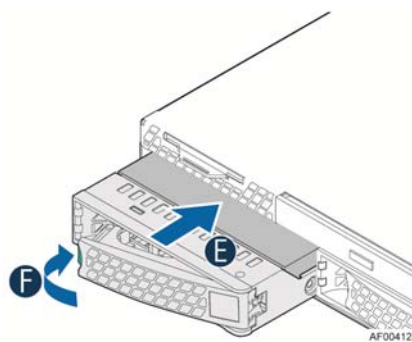

Figure 41. Installing Hard Disk Drive – Inserting 3.5" HDD assembly

Installing a Hard Disk Drive into 2.5" Hard Drive Carrier

1. Remove the drive carrier by pressing the green button (letter **A**) and slide the carrier out (letter **B**).

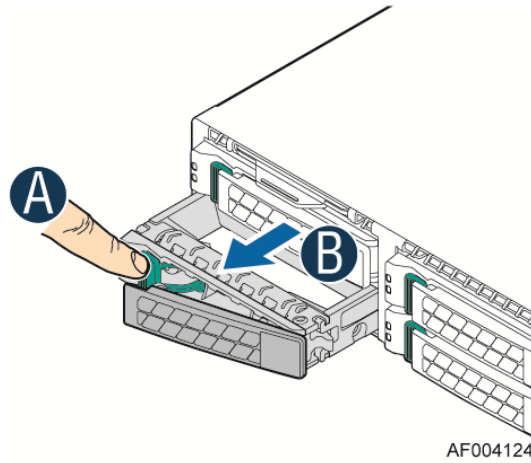

Figure 42. Installing Hard Disk Drive - Inserting

2. Remove the four screws securing the plastic drive blank from the 2.5" HDD carrier and install the 2.5" HDD with screws shown in below drawing.

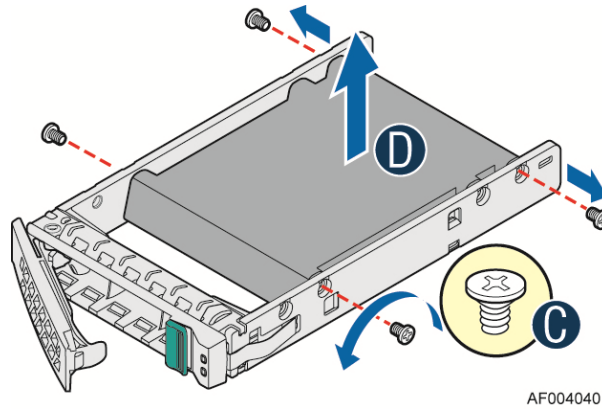

Figure 43. Installing Hard Disk Drive – Installing 2.5" HDD to Carrier

3. Insert the hard drive using the four screws as shown.

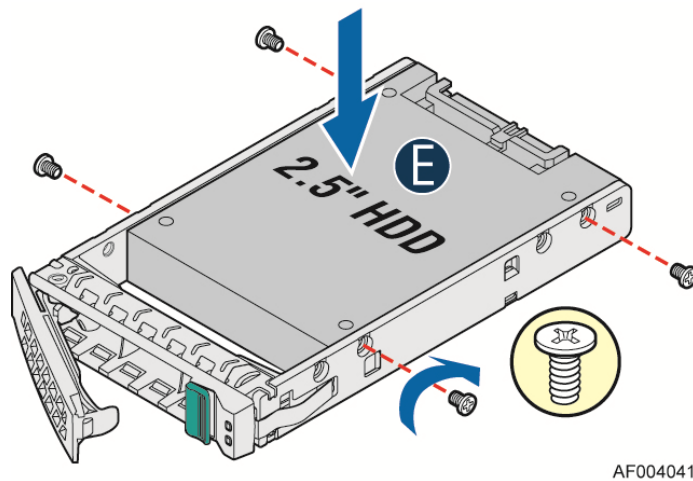
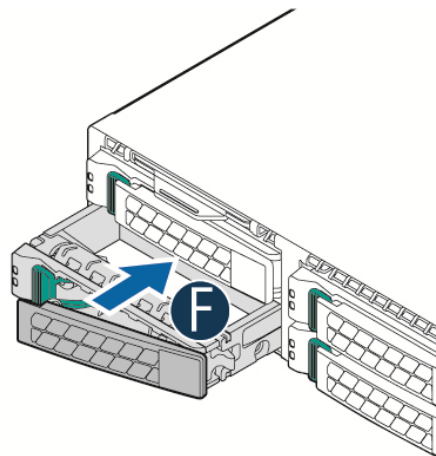

Figure 44. Installing Hard Disk Drive – Installing 2.5" HDD to Carrier

4. With the lever open, insert the hard disk drive assembly into the chassis and push in the lever to lock it into place (See letter **F**).



AF004125

Figure 45. Installing Hard Disk Drive – Inserting 2.5" HDD Assembly

Installing and Removing the PCIe Riser Assembly

On Riser Slot 1

Installing the PCI Riser Assembly and add-in card

1. Remove the riser with the bracket by removing screws in letter **A**.

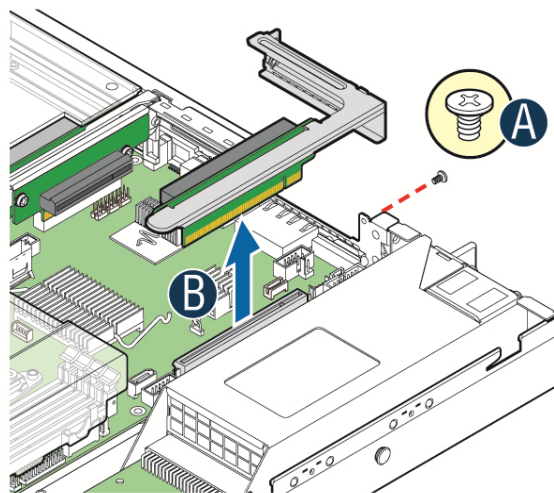

AF005727

Figure 46. Removing the Riser with Bracket

2. Plug in the PCIe add-in card to slot on riser (letter **A**) and fix the card bracket to assembly rear panel (letter **B**).

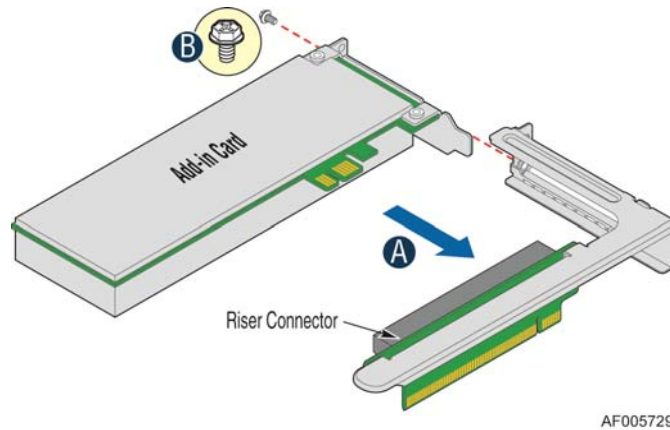

AF005729

Figure 47. Installing Riser 1 Assembly

3. Plug in the assembly to riser slot on baseboard (see letter **A**) and fasten the screw (letter **B**).

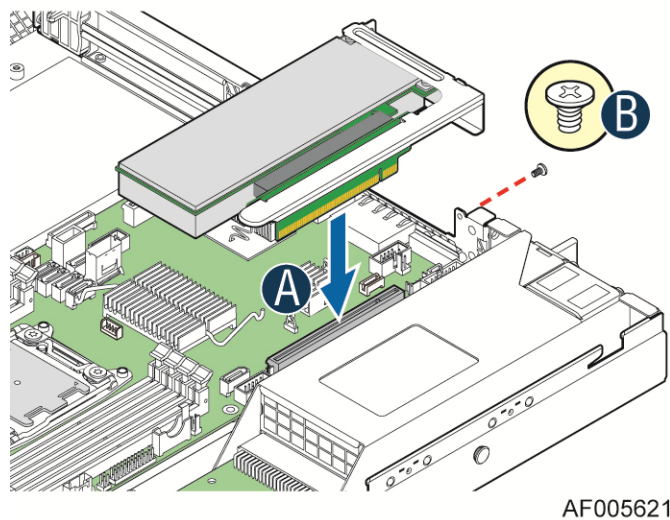

AF005621

Figure 48. Installing a PCI Adapter to PCI Riser 1 Assembly

On Riser Slot 2

Installing IOM riser and carrier assembly

The IOM riser and carrier assembly are provided as optional accessory. This assembly provides the support to Intel® RMM4 dedicated NIC port and IO module.

1. Install IO module to IOM carrier using screw in letter **A**.

Hardware Installations and Upgrades

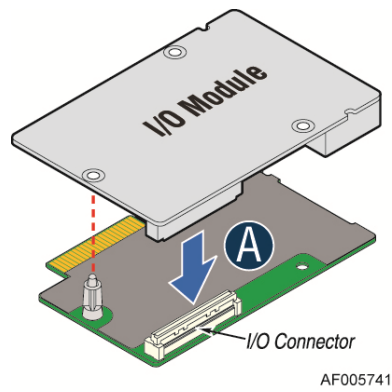

Figure 49. Installing IO Module

2. Fasten the screws to the carrier board.

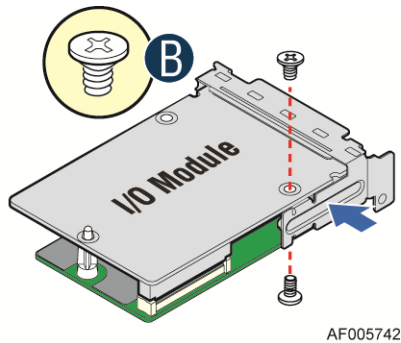

Figure 50. Installing IO module

3. Install the whole bracket to IOM riser slot indicated by letter **C**. Then install rear panel indicated by letter **D**.

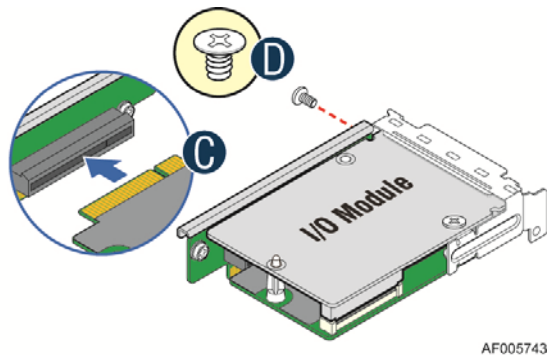

Figure 51. Installing Assembly to Riser

4. Fastening the assembly to chassis (letter **F**) with two screws in letter **E**.

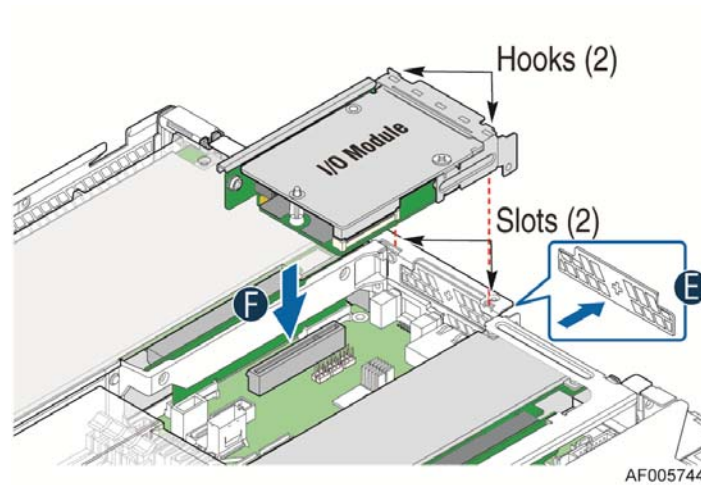

Figure 52. Fastening the Assembly in Chassis

On Riser Slot 3

Installing Double Width PCIe Add-in Card

In Intel® Server System R1304JP4OC, R1304JP4TC, R1208JP4OC, and R1208JP4TC, it supports two connectors to support 2xPCIe III x8 slots. In Intel® Server Systems R1304JP4GS and R1208JP4GS, it supports two connectors to support 1xPCIe III x16 slot.

1. Loosen the screw and remove the plate.
2. Install double width PCIe add-in card until it sits in the riser connector,
3. Rotate the PCI card Retainer to make sure the add-in card is secured in the slot.
4. Install the plate and fasten the screw.

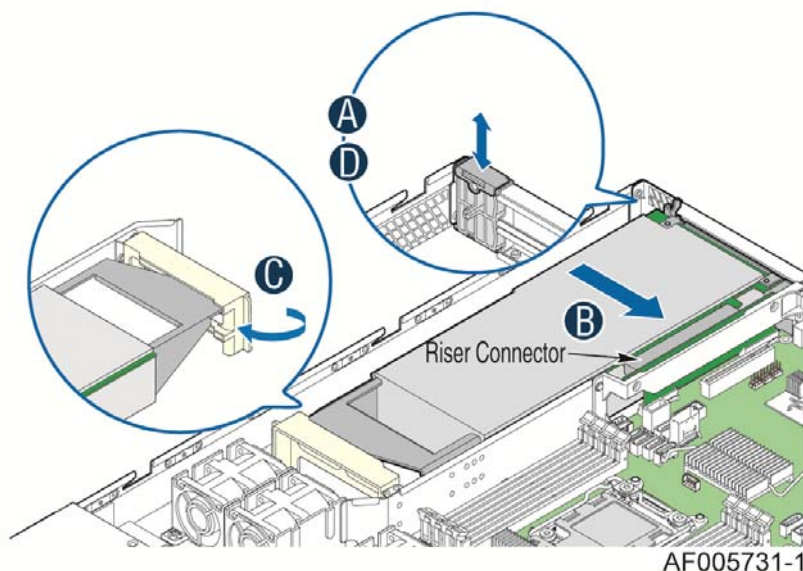

Figure 53. Installing a PCI Adapter to PCI Riser 3 Assembly

Installing the Intel® RMM4 Lite

Locate the RMM4 Lite connector next to RISER SLOT_2, carefully pick up the Intel® RMM4 Lite module, match the alignment pin of the module and the connector on server board, and press to install.

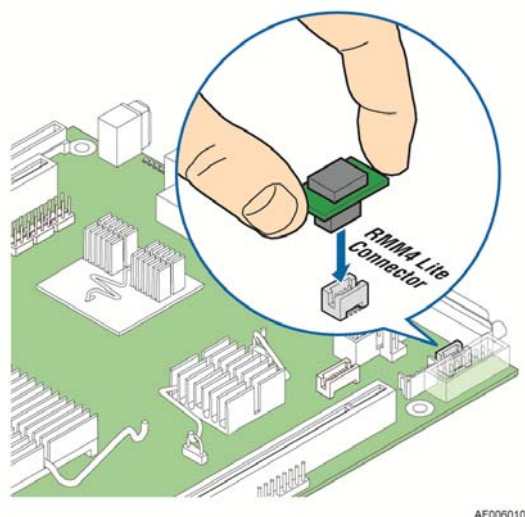

Figure 54. Installing the Intel® RMM4 Lite

Installing the Intel® Storage Upgrade Key

Installing the Intel® Storage Upgrade Key

The server board supports various Intel® Storage Upgrade Keys for different storage configuration. Below is the list of supported Storage Upgrade Key.

Table 5. Intel® RAID C600-A Storage Upgrade Key Options for S1600JP

| Intel® RAID C600 Upgrade Key Options (Intel® Product Codes) | Key Color | Description |
|---|-----------|---|
| Default – No option key installed | N/A | 4 Port SATA with Intel® ESRT2 RAID 0,1,10 and Intel® RSTe RAID 0,1,5,10 |
| RKSATA4R5 | Black | 4 Port SATA with Intel® ESRT2 RAID 0,1, 5, 10 and Intel® RSTe RAID 0,1,5,10 |
| RKSAS4 | Green | 4 Port SAS with Intel® ESRT2 RAID 0,1, 10 and Intel® RSTe RAID 0,1,10 |
| RKSAS4R5 | Yellow | 4 Port SAS with Intel® ESRT2 RAID 0,1, 5, 10 and Intel® RSTe RAID 0,1,10 |

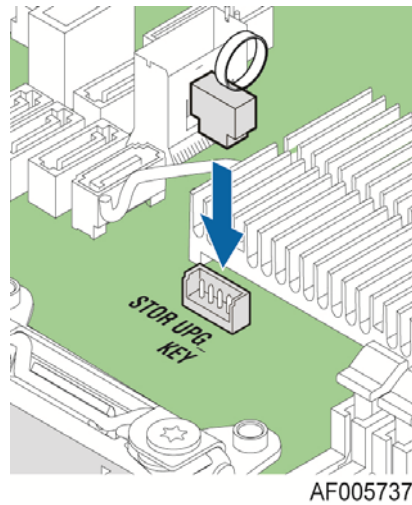

Figure 55. Installing the Intel® Storage Upgrade Key

Installing and Removing the Fan

Removing the Fan set

1. Disconnect the Fan cable.
2. Remove Fan set from dock.

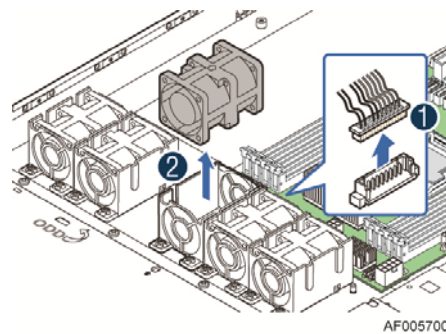

Figure 56. Removing the Fan

Installing the Fan set

1. Place the Fan set into dock.
2. Connect the Fan set cable to connector on the motherboard.

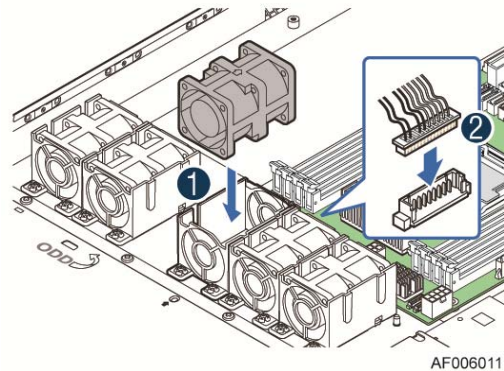

Figure 57. Installing the Fan

Installing and Removing the 2.5" Backplane Board

Removing the 2.5" Backplane board

1. Remove the screws to release the the backplane from chassis.
2. Straightly lift up the backplane board to remove from the chassis holder.

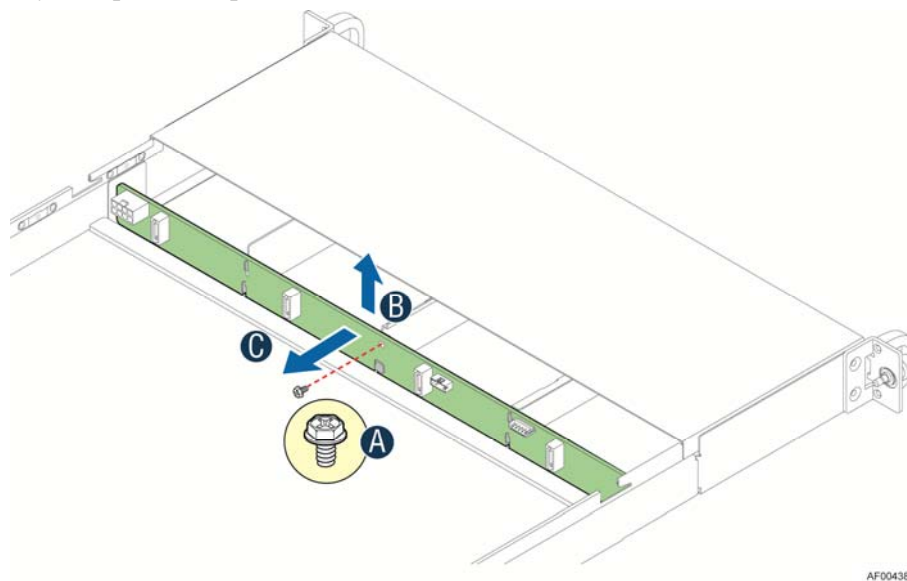

Figure 58. Removing the 2.5" Backplane Board

Installing the 2.5" Backplane board

1. Place the backplane board into the clamps on chassis base.
2. Secure the backplane board with screws (see letter C).

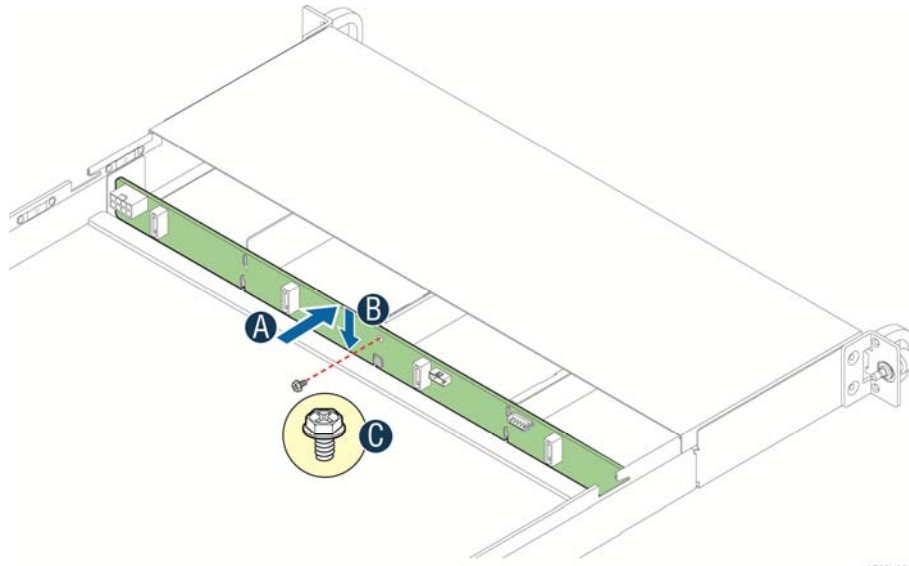

Figure 59. Align the Backplane to the Clamps on the Chassis Base

Installing and Removing the 3.5" Backplane Board

Removing the 3.5" Backplane board

1. Disconnect all cables from the backplane board.
2. Remove the three screws to release the backplane board from chassis.
3. Lift the backplane board straight up to remove from the chassis holder.

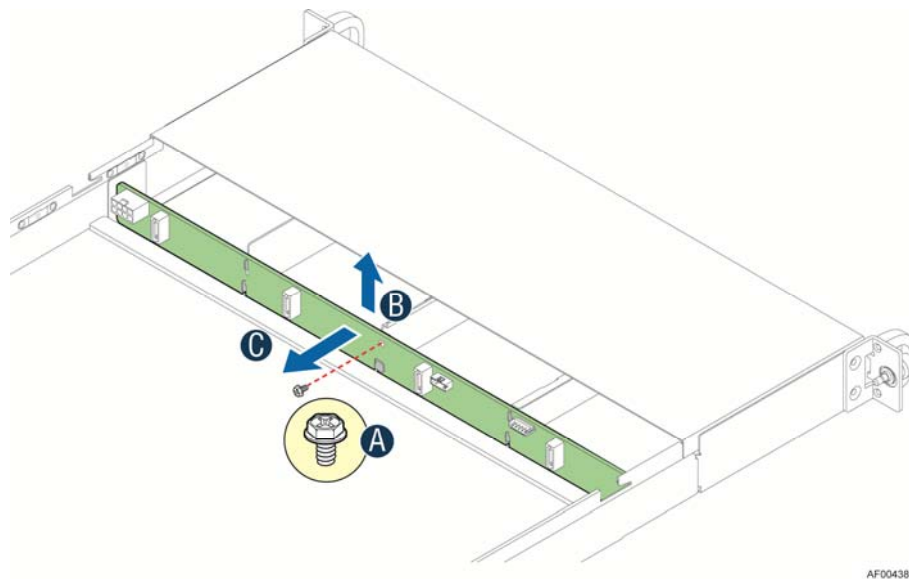

Figure 60. Removing the 3.5" Backplane Board

Installing the 3.5" Backplane board

1. Place the backplane board into the clamps on chassis base.
2. Secure the backplane board with three screws.
3. Reconnect all cables to the backplane.

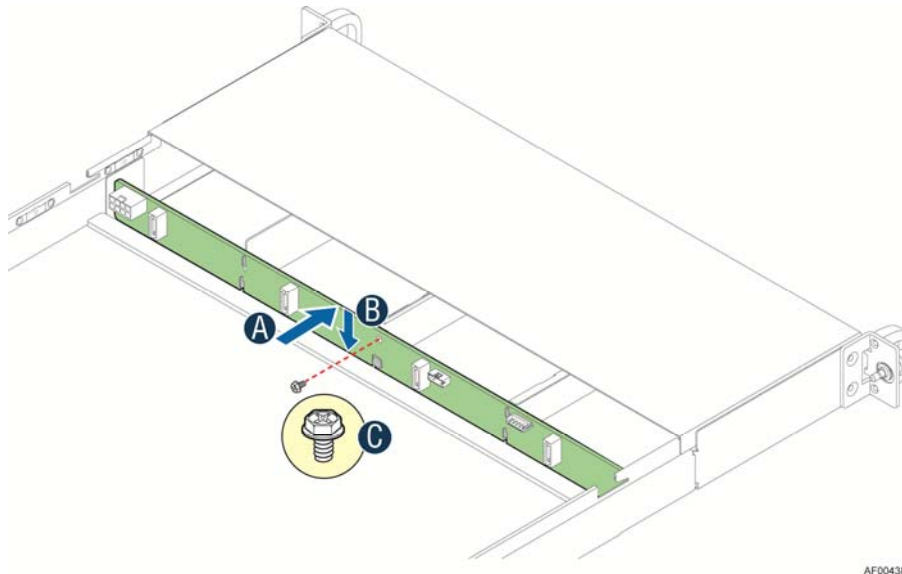
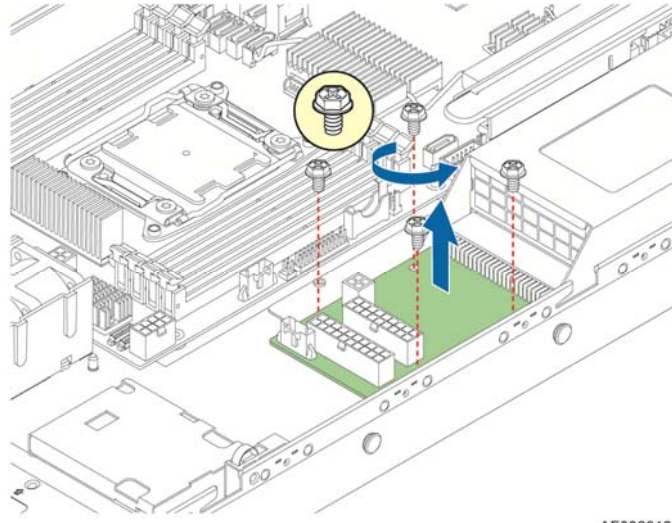

Figure 61. Installing the 3.5" Backplane Board

Installing and Removing the Power Distribution Board

Removing the PDB

1. Remove top cover and power supply units from chassis.
2. Remove power cables and PMBus* cable between PDB and backplane.
3. Release the four screws of PDB board and remove it.



AF006012

Figure 62. Removing the PDB

Installing the PDB

1. Remove top cover and power supply units from chassis.
2. Install the PDB first and secure with four screws.

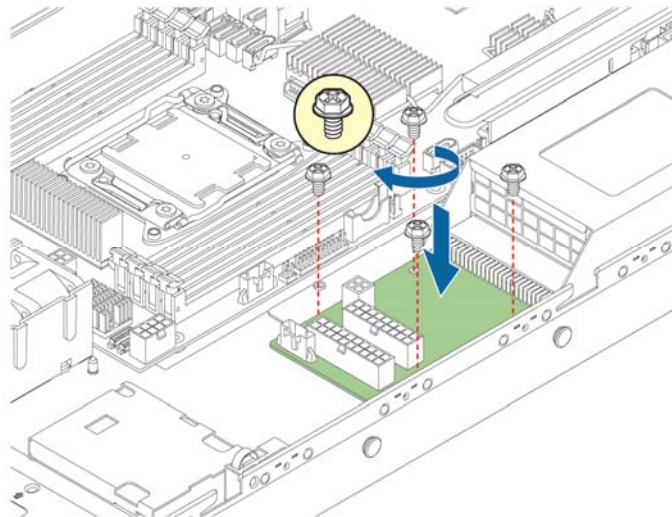

AF006013

Figure 63. Installing the PDB

3. Connect the power cables and PMBus cable to PDB.
4. Close top cover and install power supply units.

Replacing the Backup Battery

The lithium battery on the server board powers the RTC for up to 10 years in the absence of power. When the battery starts to weaken, it loses voltage, and the server settings stored in CMOS RAM in the RTC (for example, the date and time) may be wrong. Contact your customer service representative or dealer for a list of approved devices.

Warning: *Danger of explosion if battery is incorrectly replaced. Replace only with the same or equivalent type recommended by the equipment manufacturer. Discard used batteries according to manufacturer's instructions.*

Advarsel: Lithiumbatteri - Eksplosionsfare ved fejlagtig håndtering. Udskiftning må kun ske med batteri af samme fabrikat og type. Levér det brugte batteri tilbage til leverandøren.

Advarsel: Lithiumbatteri - Eksplosjonsfare. Ved utskifting benyttes kun batteri som anbefalt av apparatfabrikanten. Brukt batteri returneres apparatleverandøren.

Warning: Explosionsfara vid felaktigt batteribyte. Använd samma batterityp eller en ekvivalent typ som rekommenderas av apparattillverkaren. Kassera använt batteri enligt fabrikantens instruktion.

Varoitus: Paristo voi räjähtää, jos se on virheellisesti asennettu. Vaihda paristo ainoastaan laitevalmistajan suosittelemaan tyyppiin. Hävitä käytetty paristo valmistajan ohjeiden mukaisesti.

1. Locate the battery on the server board.
2. Gently press the metal clip as shown to release the battery (see letter **A**).
3. Remove the battery from the plastic socket (see letter **B**).

Rack Mounting the Chassis

Mounting the Chassis to the Rack

The slide rail kit, which is bundled with Intel® Server System R1000JP family, is packed in the same shipping box together with the chassis. Following are the steps to install chassis to rack:

1. Preparation before slide installation.

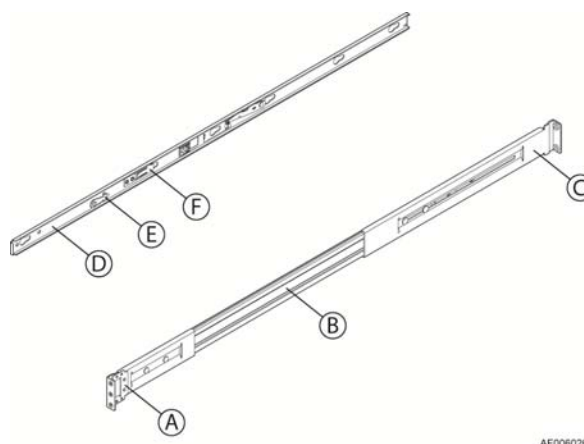

Figure 64. Mounting the Chassis to the Rack

Slides Components:

- A- Front bracket;
- B- outer member;
- C- rear bracket;
- D- inner member;
- E- Safety locking pin;
- F- Release button.

2. Install slides to rack. Align brackets to desired vertical position on rack and insert fasteners. Move the ball retainer to the front of slides.

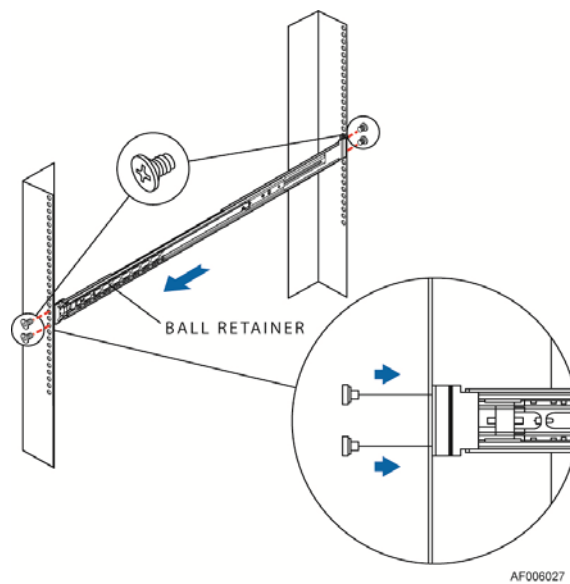
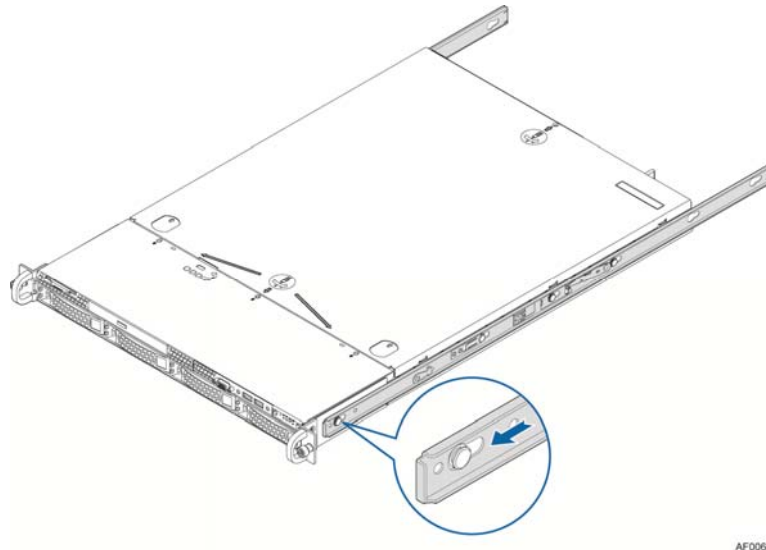

Figure 65. Installing Slides to the Rack

3. Install the inner members to chassis. Align the inner member key holes to standoffs on the chassis, and move the inner member following the direction in the picture.

Hardware Installations and Upgrades



AF006018

Figure 66. Installing Inner Member to the Chassis

4. Install chassis to fixed slides. Pull the release button in the inner member to release the lock and allow the chassis to close.

3 Server Utilities

Using the BIOS Setup Utility

This section describes the BIOS Setup Utility options, which is used to change server configuration defaults. You can run BIOS Setup with or without an operating system being present.

Starting Setup

To enter the BIOS Setup using a keyboard (or emulated keyboard); press the <F2> function key during boot time when the OEM or Intel® logo is displayed. The following message is displayed on the diagnostics screen and under the Quiet Boot logo screen:

Press <F2> to enter setup

When the Setup Utility is entered, the Main screen is displayed. However, serious errors cause the system to display the Error Manager screen instead of the Main screen.

Setup Navigation Keyboard Commands

The bottom right portion of the Setup screen provides a list of commands that are used to navigate through the Setup utility. These commands are displayed at all times.

Each Setup menu page contains a number of features. Each feature is associated with a value field, except those used for informative purposes. Each value field contains configurable parameters. Depending on the security option chosen and in effect by the password, a menu feature's value may or may not be changed. If a value cannot be changed, its field is made inaccessible and appears grayed out.

Table 6. BIOS Setup: Keyboard Command Bar

| Key | Option | Description |
|---------|-----------------|--|
| <Enter> | Execute Command | The <Enter> key is used to activate submenus when the selected feature is a submenu, or to display a pick list if a selected option has a value field, or to select a subfield for multi-valued features like time and date. If a pick list is displayed, the <Enter> key selects the currently highlighted item, undoes the pick list, and returns the focus to the parent menu. |
| <Esc> | Exit | The <Esc> key provides a mechanism for backing out of any field. When the <Esc> key is pressed while editing any field or selecting features of a menu, the parent menu is re-entered. When the <Esc> key is pressed in any submenu, the parent menu is re-entered. When the <Esc> key is pressed in any major menu, the exit confirmation window is displayed and the user is asked whether changes can be discarded. If “No” is selected and the <Enter> key is pressed, or if the <Esc> key is pressed, the user is returned to where they were before <Esc> was pressed, without affecting any existing settings. If “Yes” is selected and the <Enter> key is pressed, the setup is exited and the BIOS returns to the main System Options Menu screen. |
| ↑ | Select Item | The up arrow is used to select the previous value in a pick list, or the previous option in a menu item's option list. The selected item must then be activated by pressing the <Enter> key. |
| | Select Item | The down arrow is used to select the next value in a menu item's option list, or a value field's pick list. The selected item must then be activated by pressing the <Enter> key. |
| | Select Menu | The left and right arrow keys are used to move between the major menu pages. The keys have no effect if a sub-menu or pick list is displayed. |
| <Tab> | Select Field | The <Tab> key is used to move between fields. For example, <Tab> can be used to move from hours to minutes in the time item in the main menu. |

Server Utilities

| Key | Option | Description |
|-------|----------------|--|
| - | Change Value | The minus key on the keypad is used to change the value of the current item to the previous value. This key scrolls through the values in the associated pick list without displaying the full list. |
| + | Change Value | The plus key on the keypad is used to change the value of the current menu item to the next value. This key scrolls through the values in the associated pick list without displaying the full list. On 106-key Japanese keyboards, the plus key has a different scan code than the plus key on the other keyboards, but will have the same effect. |
| <F9> | Setup Defaults | <p>Pressing the <F9> key causes the following to display:</p> <div style="border: 1px solid black; padding: 5px; text-align: center;"> Load Optimized Defaults? Yes No </div> <p>If “Yes” is highlighted and <Enter> is pressed, all Setup fields are set to their default values. If “No” is highlighted and <Enter> is pressed, or if the <Esc> key is pressed, the user is returned to where they were before <F9> was pressed without affecting any existing field values.</p> |
| <F10> | Save and Exit | <p>Pressing the <F10> key causes the following message to display:</p> <div style="border: 1px solid black; padding: 5px; text-align: center;"> Save configuration and reset? Yes No </div> <p>If “Yes” is highlighted and <Enter> is pressed, all changes are saved and the Setup is exited. If “No” is highlighted and <Enter> is pressed, or the <Esc> key is pressed, the user is returned to where they were before <F10> was pressed without affecting any existing values.</p> |

Setup Screen Menu Selection Bar

The Setup Screen Menu selection bar is located at the top of the BIOS Setup Utility screen. It displays tabs showing the major screen selections available to the user. By using the left and right arrow keys, the user can select the listed screens. Some screen selections are out of the visible menu space, and become available by scrolling to the left or right of the current selections displayed.

BIOS Setup Utility Screens

The following sections describe the screens available in the BIOS Setup utility for the configuration of the server platform.

For each of these screens, there is an image of the screen with a list of Field Descriptions which describe the contents of each item on the screen. Each item on the screen is hyperlinked to the relevant Field Description. Each Field Description is hyperlinked back to the screen image.

These lists follow the following guidelines:

- The text heading for each Field Description is the actual text as displayed on the BIOS Setup screen. This screen text is a hyperlink to its corresponding Field Description.
- The text shown in the Option Values and Help Text entries in each Field Description are the actual text and values are displayed on the BIOS Setup screens.
- In the Option Values entries, the text for default values is shown with an underline. These values do not appear underline on the BIOS Setup screen. The underlined text in this document is to serve as a reference to which value is the default value.

- The Help Text entry is the actual text which appears on the screen to accompany the item when the item is the one in focus (active on the screen).
- The Comments entry provides additional information where it may be helpful. This information does not appear on the BIOS Setup screens.
- Information enclosed in angular brackets (< >) in the screen shots identifies text that can vary, depending on the option(s) installed. For example, <Amount of memory installed> is replaced by the actual value for “Total Memory”.
- Information enclosed in square brackets ([]) in the tables identifies areas where the user must type in text instead of selecting from a provided option.
- Whenever information is changed (except Date and Time), the systems requires a save and reboot to take place in order for the changes to take effect. Alternatively, pressing <ESC> discards the changes and resumes POST to continue to boot the system according to the boot order set from the last boot.

Map of Screens and Functionality

There are a number of screens in the entire Setup collection. They are organized into major categories. Each category has a hierarchy beginning with a top-level screen from which lower-level screens may be selected. Each top-level screen appears as a tab, arranged across the top of the Setup screen image of all top-level screens.

There are more categories than will fit across the top of the screen, so at any given time there will be some categories which will not appear until the user has scrolled across the tabs which are present. The categories and the screens included in each category are listed below.

Table 7. Screen Map

| Categories (Top Tabs) | 2 nd Level Screens | 3 rd Level Screens |
|-----------------------|---|--|
| Main Screen (Tab) | | |
| Advanced Screen (Tab) | | |
| ⌘ | Processor Configuration | |
| ⌘ | Memory Configuration | |
| | ⌘ | Memory RAS and Performance Configuration |
| ⌘ | Mass Storage Controller Configuration | |
| ⌘ | PCI Configuration | |
| ⌘ | Serial Port Configuration | |
| ⌘ | USB Configuration | |
| ⌘ | System Acoustic and Performance Configuration | |

Server Utilities

| Categories (Top Tabs) | 2 nd Level Screens | 3 rd Level Screens |
|--------------------------------|-------------------------------|-------------------------------|
| Security Screen (Tab) | | |
| Server Management Screen (Tab) | | |
| ☞ | Console Redirection | |
| ☞ | System Information | |
| ☞ | BMC LAN Configuration | |
| Boot Options Screen (Tab) | | |
| ☞ | CDROM Order | |
| ☞ | Hard Disk Order | |
| ☞ | Floppy Order | |
| ☞ | Network Device Order | |
| ☞ | BEV Device Order | |
| ☞ | Add EFI Boot Option | |
| ☞ | Delete EFI Boot Option | |
| Boot Manager Screen (Tab) | | |
| Error Manager Screen (Tab) | | |
| Save and Exit Screen (Tab) | | |

Appendix A: Technical Reference

System Environmental Specifications

The following table defines the system level operating and non-operating environmental limits.

Table 8. System Environmental Limits Summary

| Parameter | Limits |
|--------------------------------------|---|
| Operating Temperature | +10°C to +35°C with the maximum rate of change not to exceed 10°C per hour |
| Non-Operating Temperature | -40°C to +70°C |
| Non-Operating Humidity | 90%, non-condensing at 35°C |
| Acoustic noise | Sound power: - 3.5" HDD SKU: 6.9BA at idle and 7.4BA at active mode; - 2.5" HDD SKU: 6.5BA at idle and 7.07BA at active mode. |
| Shock, operating | Half sine, 2g peak, 11 milliseconds |
| Shock, unpackaged | Trapezoidal, 25g, velocity change 136 inches/second (40 lbs to < 80 lbs) |
| Shock, packaged | Non-palletized free fall in height 24 inches (40 lbs to < 80 lbs) |
| Vibration, unpackaged | 5 Hz to 500 Hz, 2.20 g RMS random |
| ESD | +/-12 KV except I/O port +/- 8 KV per Intel® Environmental test specification |
| System Cooling Requirement in BTU/Hr | 1200 Watt Max – 4095 BTU/hour 1600 Watt Max – 5459 BTU/hour |

Appendix B: Regulatory and Compliance Information

Please refer to the *Server Products Regulatory and Safety* document for the product regulatory compliance reference. The document can be downloaded from http://www.intel.com/p/en_US/support/server/.

Appendix C: LED Decoder

During the system boot process, the BIOS executes a number of platform configuration processes, each of which is assigned a specific hex POST code number. As each configuration routine is started, the BIOS displays the POST code to the POST Code.

Diagnostic LEDs found on the back edge of the server board. To assist in troubleshooting a system hang during the POST process, the Diagnostic LEDs can be used to identify the last POST process to be executed.

Each POST code is represented by the eight amber Diagnostic LEDs. The POST codes are divided into two nibbles, an upper nibble and a lower nibble. The upper nibble bits are represented by Diagnostic LEDs #4, #5, #6, #7. The lower nibble bits are represented by Diagnostics LEDs #0, #1, #2 and #3. If the bit is set in the upper and lower nibbles, then the corresponding LED is lit. If the bit is clear, then the corresponding LED is off.

The Diagnostic LED #7 is labeled as “MSB”, and the Diagnostic LED #0 is labeled as “LSB”.

In the following example, the BIOS sends a value of ACh to the diagnostic LED decoder.

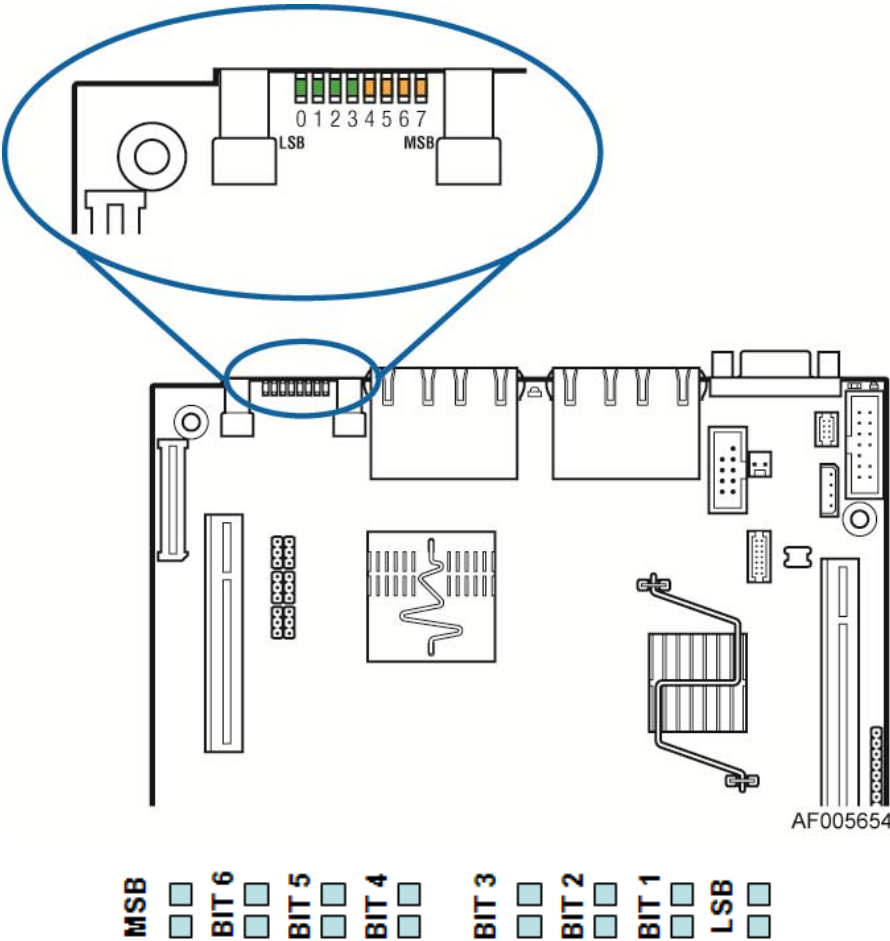

Figure 67. Diagnostic LED Placement Diagram

Appendix C: LED Decoder

The LEDs are decoded as follows:

Table 9. POST Progress Code LED Example

| LEDs | Upper Nibble LEDs | | | | Lower Nibble LEDs | | | |
|----------------|-------------------|--------|--------|--------|-------------------|--------|--------|--------|
| | MSB | | | | | | | LSB |
| | LED #7 | LED #6 | LED #5 | LED #4 | LED #3 | LED #2 | LED #1 | LED #0 |
| | 8h | 4h | 2h | 1h | 8h | 4h | 2h | 1h |
| Status | ON | OFF | ON | OFF | ON | ON | OFF | OFF |
| Results | 1 | 0 | 1 | 0 | 1 | 1 | 0 | 0 |
| | Ah | | | | Ch | | | |

- Upper nibble bits = 1010b = Ah;

- Lower nibble bits = 1100b = Ch;

The two are concatenated as Ach.

Table 10. Diagnostic LED POST Code Decoder

| Checkpoint | Diagnostic LED Decoder | | | | | | | | Description |
|-----------------------|------------------------|----|----|----|--------------|----|----|-----|---|
| | 1 = On, 0=Off | | | | | | | | |
| | Upper Nibble | | | | Lower Nibble | | | | |
| | MSB | | | | | | | LSB | |
| | 8h | 4h | 2h | 1h | 8h | 4h | 2h | 1h | |
| LED | #7 | #6 | #5 | #4 | #3 | #2 | #1 | #0 | |
| Host Processor | | | | | | | | | |
| 0x10h | 0 | 0 | 0 | 1 | 0 | 0 | 0 | 0 | Power-on initialization of the host processor (bootstrap processor) |
| 0x11h | 0 | 0 | 0 | 1 | 0 | 0 | 0 | 1 | Host processor cache initialization (including AP) |
| 0x12h | 0 | 0 | 0 | 1 | 0 | 0 | 1 | 0 | Starting application processor initialization |
| 0x13h | 0 | 0 | 0 | 1 | 0 | 0 | 1 | 1 | SMM initialization |
| Chipset | | | | | | | | | |
| 0x21h | 0 | 0 | 1 | 0 | 0 | 0 | 0 | 1 | Initializing a chipset component |
| Memory | | | | | | | | | |
| 0x22h | 0 | 0 | 1 | 0 | 0 | 0 | 1 | 0 | Reading configuration data from memory (SPD on FBDIMM) |
| 0x23h | 0 | 0 | 1 | 0 | 0 | 0 | 1 | 1 | Detecting presence of memory |

| Checkpoint | Diagnostic LED Decoder | | | | | | | | Description |
|-------------------------------------|------------------------|----|----|----|--------------|----|----|-----|---|
| | 1 = On, 0=Off | | | | | | | | |
| | Upper Nibble | | | | Lower Nibble | | | | |
| | MSB | | | | | | | LSB | |
| | 8h | 4h | 2h | 1h | 8h | 4h | 2h | 1h | |
| LED | #7 | #6 | #5 | #4 | #3 | #2 | #1 | #0 | |
| 0x24h | 0 | 0 | 1 | 0 | 0 | 1 | 0 | 0 | Programming timing parameters in the memory controller |
| 0x25h | 0 | 0 | 1 | 0 | 0 | 1 | 0 | 1 | Configuring memory parameters in the memory controller |
| 0x26h | 0 | 0 | 1 | 0 | 0 | 1 | 1 | 0 | Optimizing memory controller settings |
| 0x27h | 0 | 0 | 1 | 0 | 0 | 1 | 1 | 1 | Initializing memory, such as ECC in it |
| 0x28h | 0 | 0 | 1 | 0 | 1 | 0 | 0 | 0 | Testing memory |
| 0xE4h | 1 | 1 | 1 | 0 | 0 | 1 | 0 | 0 | BIOS cannot communicate with DIMM (serial channel hardware failure) |
| 0xE6h | 1 | 1 | 1 | 0 | 0 | 1 | 1 | 0 | DIMM(s) failed Memory iBIST or Memory Link Training failure |
| 0xE8h | 1 | 1 | 1 | 0 | 1 | 0 | 0 | 0 | No memory available (system halted) |
| 0xE9h | 1 | 1 | 1 | 0 | 1 | 0 | 0 | 1 | Unsupported or invalid DIMM configuration (system halted) |
| 0xEAh | 1 | 1 | 1 | 0 | 1 | 0 | 1 | 0 | DIMM training sequence failed (system halted) |
| 0xEBh | 1 | 1 | 1 | 0 | 1 | 0 | 1 | 1 | Memory test failed (system halted) |
| 0xECh | 1 | 1 | 1 | 0 | 1 | 1 | 0 | 0 | Unsupported or invalid DIMM configuration (system halted) |
| 0xEDh | 1 | 1 | 1 | 0 | 1 | 1 | 0 | 1 | Unsupported or invalid DIMM configuration (system halted) |
| 0xEBh | 1 | 1 | 1 | 0 | 1 | 0 | 1 | 1 | DIMM with corrupted SPD data detected (system halted) |
| QuickPath Interconnect (QPI) | | | | | | | | | |
| 0xA0h | 1 | 0 | 1 | 0 | 0 | 0 | 0 | 0 | QPI Initialization |
| 0xA1h | 1 | 0 | 1 | 0 | 0 | 0 | 0 | 1 | QPI Initialization |
| 0xA2h | 1 | 0 | 1 | 0 | 0 | 0 | 1 | 0 | QPI Initialization |
| 0xA3h | 1 | 0 | 1 | 0 | 0 | 0 | 1 | 1 | QPI Initialization |
| 0xA4h | 1 | 0 | 1 | 0 | 0 | 1 | 0 | 0 | QPI Initialization |

Appendix C: LED Decoder

| Checkpoint | Diagnostic LED Decoder | | | | | | | | Description |
|---|------------------------|----|----|----|--------------|----|----|-----|---|
| | 1 = On, 0=Off | | | | | | | | |
| | Upper Nibble | | | | Lower Nibble | | | | |
| | MSB | | | | | | | LSB | |
| | 8h | 4h | 2h | 1h | 8h | 4h | 2h | 1h | |
| LED | #7 | #6 | #5 | #4 | #3 | #2 | #1 | #0 | |
| 0xA5h | 1 | 0 | 1 | 0 | 0 | 1 | 0 | 1 | QPI Initialization |
| 0xA6h | 1 | 0 | 1 | 0 | 0 | 1 | 1 | 0 | QPI Initialization |
| 0xA7h | 1 | 0 | 1 | 0 | 0 | 1 | 1 | 1 | QPI Initialization |
| 0xA8h | 1 | 0 | 1 | 0 | 1 | 0 | 0 | 0 | QPI Initialization |
| 0xA9h | 1 | 0 | 1 | 0 | 1 | 0 | 0 | 1 | QPI Initialization |
| 0xAAh | 1 | 0 | 1 | 0 | 1 | 0 | 1 | 0 | QPI Initialization |
| 0xABh | 1 | 0 | 1 | 0 | 1 | 0 | 1 | 1 | QPI Initialization |
| 0xACh | 1 | 0 | 1 | 0 | 1 | 1 | 0 | 0 | QPI Initialization |
| 0xADh | 1 | 0 | 1 | 0 | 1 | 1 | 0 | 1 | QPI Initialization |
| 0xAEh | 1 | 0 | 1 | 0 | 1 | 1 | 1 | 0 | QPI Initialization |
| 0xAFh | 1 | 0 | 1 | 0 | 1 | 1 | 1 | 1 | QPI Initialization |
| Integrated Memory Controller (IMC) | | | | | | | | | |
| 0xB0h | 1 | 0 | 1 | 1 | 0 | 0 | 0 | 0 | Memory Initialization of Integrated Memory Controller |
| 0xB1h | 1 | 0 | 1 | 1 | 0 | 0 | 0 | 1 | Memory Initialization of Integrated Memory Controller |
| 0xB2h | 1 | 0 | 1 | 1 | 0 | 0 | 1 | 0 | Memory Initialization of Integrated Memory Controller |
| 0xB3h | 1 | 0 | 1 | 1 | 0 | 0 | 1 | 1 | Memory Initialization of Integrated Memory Controller |
| 0xB4h | 1 | 0 | 1 | 1 | 0 | 1 | 0 | 0 | Memory Initialization of Integrated Memory Controller |
| 0xB5h | 1 | 0 | 1 | 1 | 0 | 1 | 0 | 1 | Memory Initialization of Integrated Memory Controller |
| 0xB6h | 1 | 0 | 1 | 1 | 0 | 1 | 1 | 0 | Memory Initialization of Integrated Memory Controller |
| 0xB7h | 1 | 0 | 1 | 1 | 0 | 1 | 1 | 1 | Memory Initialization of Integrated Memory Controller |

| Checkpoint | Diagnostic LED Decoder | | | | | | | | Description |
|-------------------------------------|------------------------|----|----|----|--------------|----|----|-----|---|
| | 1 = On, 0=Off | | | | | | | | |
| | Upper Nibble | | | | Lower Nibble | | | | |
| | MSB | | | | | | | LSB | |
| | 8h | 4h | 2h | 1h | 8h | 4h | 2h | 1h | |
| LED | #7 | #6 | #5 | #4 | #3 | #2 | #1 | #0 | |
| 0xB8h | 1 | 0 | 1 | 1 | 1 | 0 | 0 | 0 | Memory Initialization of Integrated Memory Controller |
| 0xB9h | 1 | 0 | 1 | 1 | 1 | 0 | 0 | 1 | Memory Initialization of Integrated Memory Controller |
| 0xBAh | 1 | 0 | 1 | 1 | 1 | 0 | 1 | 0 | Memory Initialization of Integrated Memory Controller |
| 0xBBh | 1 | 0 | 1 | 1 | 1 | 0 | 1 | 1 | Memory Initialization of Integrated Memory Controller |
| 0xBCh | 1 | 0 | 1 | 1 | 1 | 1 | 0 | 0 | Memory Initialization of Integrated Memory Controller |
| 0xBDh | 1 | 0 | 1 | 1 | 1 | 1 | 0 | 1 | Memory Initialization of Integrated Memory Controller |
| 0xBEh | 1 | 0 | 1 | 1 | 1 | 1 | 1 | 0 | Memory Initialization of Integrated Memory Controller |
| 0xBFh | 1 | 0 | 1 | 1 | 1 | 1 | 1 | 1 | Memory Initialization of Integrated Memory Controller |
| PCI Bus | | | | | | | | | |
| 0x50h | 0 | 1 | 0 | 1 | 0 | 0 | 0 | 0 | Enumerating PCI buses |
| 0x51h | 0 | 1 | 0 | 1 | 0 | 0 | 0 | 1 | Allocating resources to PCI buses |
| 0x52h | 0 | 1 | 0 | 1 | 0 | 0 | 1 | 0 | Hot Plug PCI controller initialization |
| 0x53h | 0 | 1 | 0 | 1 | 0 | 0 | 1 | 1 | Reserved for PCI bus |
| 0x54h | 0 | 1 | 0 | 1 | 0 | 1 | 0 | 0 | Reserved for PCI bus |
| 0x55h | 0 | 1 | 0 | 1 | 0 | 1 | 0 | 1 | Reserved for PCI bus |
| QuickPath Interconnect (QPI) | | | | | | | | | |
| 0xA0h | 1 | 0 | 1 | 0 | 0 | 0 | 0 | 0 | QPI Initialization |
| 0xA1h | 1 | 0 | 1 | 0 | 0 | 0 | 0 | 1 | QPI Initialization |
| 0xA2h | 1 | 0 | 1 | 0 | 0 | 0 | 1 | 0 | QPI Initialization |
| 0xA3h | 1 | 0 | 1 | 0 | 0 | 0 | 1 | 1 | QPI Initialization |

Appendix C: LED Decoder

| Checkpoint | Diagnostic LED Decoder | | | | | | | | Description |
|---|------------------------|----|----|----|--------------|----|----|-----|---|
| | 1 = On, 0=Off | | | | | | | | |
| | Upper Nibble | | | | Lower Nibble | | | | |
| | MSB | | | | | | | LSB | |
| | 8h | 4h | 2h | 1h | 8h | 4h | 2h | 1h | |
| LED | #7 | #6 | #5 | #4 | #3 | #2 | #1 | #0 | |
| 0xA4h | 1 | 0 | 1 | 0 | 0 | 1 | 0 | 0 | QPI Initialization |
| 0xA5h | 1 | 0 | 1 | 0 | 0 | 1 | 0 | 1 | QPI Initialization |
| 0xA6h | 1 | 0 | 1 | 0 | 0 | 1 | 1 | 0 | QPI Initialization |
| 0xA7h | 1 | 0 | 1 | 0 | 0 | 1 | 1 | 1 | QPI Initialization |
| 0xA8h | 1 | 0 | 1 | 0 | 1 | 0 | 0 | 0 | QPI Initialization |
| 0xA9h | 1 | 0 | 1 | 0 | 1 | 0 | 0 | 1 | QPI Initialization |
| 0xAAh | 1 | 0 | 1 | 0 | 1 | 0 | 1 | 0 | QPI Initialization |
| 0xABh | 1 | 0 | 1 | 0 | 1 | 0 | 1 | 1 | QPI Initialization |
| 0xACh | 1 | 0 | 1 | 0 | 1 | 1 | 0 | 0 | QPI Initialization |
| 0xADh | 1 | 0 | 1 | 0 | 1 | 1 | 0 | 1 | QPI Initialization |
| 0xAEh | 1 | 0 | 1 | 0 | 1 | 1 | 1 | 0 | QPI Initialization |
| 0xAFh | 1 | 0 | 1 | 0 | 1 | 1 | 1 | 1 | QPI Initialization |
| Integrated Memory Controller (IMC) | | | | | | | | | |
| 0xB0h | 1 | 0 | 1 | 1 | 0 | 0 | 0 | 0 | Memory Initialization of Integrated Memory Controller |
| 0xB1h | 1 | 0 | 1 | 1 | 0 | 0 | 0 | 1 | Memory Initialization of Integrated Memory Controller |
| 0xB2h | 1 | 0 | 1 | 1 | 0 | 0 | 1 | 0 | Memory Initialization of Integrated Memory Controller |
| 0xB3h | 1 | 0 | 1 | 1 | 0 | 0 | 1 | 1 | Memory Initialization of Integrated Memory Controller |
| 0xB4h | 1 | 0 | 1 | 1 | 0 | 1 | 0 | 0 | Memory Initialization of Integrated Memory Controller |
| 0xB5h | 1 | 0 | 1 | 1 | 0 | 1 | 0 | 1 | Memory Initialization of Integrated Memory Controller |
| 0xB6h | 1 | 0 | 1 | 1 | 0 | 1 | 1 | 0 | Memory Initialization of Integrated Memory Controller |
| 0xB7h | 1 | 0 | 1 | 1 | 0 | 1 | 1 | 1 | Memory Initialization of Integrated Memory Controller |

| Checkpoint | Diagnostic LED Decoder | | | | | | | | Description |
|----------------|------------------------|----|----|----|--------------|----|----|-----|---|
| | 1 = On, 0=Off | | | | | | | | |
| | Upper Nibble | | | | Lower Nibble | | | | |
| | MSB | | | | | | | LSB | |
| | 8h | 4h | 2h | 1h | 8h | 4h | 2h | 1h | |
| LED | #7 | #6 | #5 | #4 | #3 | #2 | #1 | #0 | |
| | | | | | | | | | Controller |
| 0xB8h | 1 | 0 | 1 | 1 | 1 | 0 | 0 | 0 | Memory Initialization of Integrated Memory Controller |
| 0xB9h | 1 | 0 | 1 | 1 | 1 | 0 | 0 | 1 | Memory Initialization of Integrated Memory Controller |
| 0xBAh | 1 | 0 | 1 | 1 | 1 | 0 | 1 | 0 | Memory Initialization of Integrated Memory Controller |
| 0xBBh | 1 | 0 | 1 | 1 | 1 | 0 | 1 | 1 | Memory Initialization of Integrated Memory Controller |
| 0xBCh | 1 | 0 | 1 | 1 | 1 | 1 | 0 | 0 | Memory Initialization of Integrated Memory Controller |
| 0xBDh | 1 | 0 | 1 | 1 | 1 | 1 | 0 | 1 | Memory Initialization of Integrated Memory Controller |
| 0xBEh | 1 | 0 | 1 | 1 | 1 | 1 | 1 | 0 | Memory Initialization of Integrated Memory Controller |
| 0xBFh | 1 | 0 | 1 | 1 | 1 | 1 | 1 | 1 | Memory Initialization of Integrated Memory Controller |
| PCI Bus | | | | | | | | | |
| 0x50h | 0 | 1 | 0 | 1 | 0 | 0 | 0 | 0 | Enumerating PCI buses |
| 0x51h | 0 | 1 | 0 | 1 | 0 | 0 | 0 | 1 | Allocating resources to PCI buses |
| 0x52h | 0 | 1 | 0 | 1 | 0 | 0 | 1 | 0 | Hot Plug PCI controller initialization |
| 0x53h | 0 | 1 | 0 | 1 | 0 | 0 | 1 | 1 | Reserved for PCI bus |
| 0x54h | 0 | 1 | 0 | 1 | 0 | 1 | 0 | 0 | Reserved for PCI bus |
| 0x55h | 0 | 1 | 0 | 1 | 0 | 1 | 0 | 1 | Reserved for PCI bus |
| USB | | | | | | | | | |
| 0x56h | 0 | 1 | 0 | 1 | 0 | 1 | 1 | 0 | Initializing USB host controllers |
| 0x57h | 0 | 1 | 0 | 1 | 0 | 1 | 1 | 1 | Detecting USB devices |
| 0x58h | 0 | 1 | 0 | 1 | 1 | 0 | 0 | 0 | Resetting USB bus |

Appendix C: LED Decoder

| Checkpoint | Diagnostic LED Decoder | | | | | | | | Description |
|----------------------------|------------------------|----|----|----|--------------|----|----|-----|---|
| | 1 = On, 0=Off | | | | | | | | |
| | Upper Nibble | | | | Lower Nibble | | | | |
| | MSB | | | | | | | LSB | |
| | 8h | 4h | 2h | 1h | 8h | 4h | 2h | 1h | |
| LED | #7 | #6 | #5 | #4 | #3 | #2 | #1 | #0 | |
| 0x59h | 0 | 1 | 0 | 1 | 1 | 0 | 0 | 1 | Reserved for USB devices |
| ATA/ATAPI/SATA | | | | | | | | | |
| 0x5Ah | 0 | 1 | 0 | 1 | 1 | 0 | 1 | 0 | Resetting SATA bus and all devices |
| 0x5Bh | 0 | 1 | 0 | 1 | 1 | 0 | 1 | 1 | Detecting the presence of ATA device |
| 0x5Ch | 0 | 1 | 0 | 1 | 1 | 1 | 0 | 0 | Enable SMART if supported by ATA device |
| 0x5Dh | 0 | 1 | 0 | 1 | 1 | 1 | 0 | 1 | Reserved for ATA |
| SMBUS* | | | | | | | | | |
| 0x5Eh | 0 | 1 | 0 | 1 | 1 | 1 | 1 | 0 | Resetting SMBUS* |
| 0x5Fh | 0 | 1 | 0 | 1 | 1 | 1 | 1 | 1 | Reserved for SMBUS* |
| I/O Controller Hub | | | | | | | | | |
| 0x61h | 0 | 1 | 1 | 0 | 0 | 0 | 0 | 1 | Initializing I/O Controller Hub |
| Super I/O | | | | | | | | | |
| 0x63h | 0 | 1 | 1 | 0 | 0 | 0 | 1 | 1 | Initializing Super I/O |
| Local Console | | | | | | | | | |
| 0x70h | 0 | 1 | 1 | 1 | 0 | 0 | 0 | 0 | Resetting the video controller (VGA) |
| 0x71h | 0 | 1 | 1 | 1 | 0 | 0 | 0 | 1 | Disabling the video controller (VGA) |
| 0x72h | 0 | 1 | 1 | 1 | 0 | 0 | 1 | 0 | Enabling the video controller (VGA) |
| 0x73h | 0 | 1 | 1 | 1 | 0 | 0 | 1 | 1 | Reserved for video controller (VGA) |
| Remote Console | | | | | | | | | |
| 0x78h | 0 | 1 | 1 | 1 | 1 | 0 | 0 | 0 | Resetting the console controller |
| 0x79h | 0 | 1 | 1 | 1 | 1 | 0 | 0 | 1 | Disabling the console controller |
| 0x7Ah | 0 | 1 | 1 | 1 | 1 | 0 | 1 | 0 | Enabling the console controller |
| 0x7Bh | 0 | 1 | 1 | 1 | 1 | 0 | 1 | 1 | Reserved for console controller |
| Keyboard (only USB) | | | | | | | | | |
| 0x90h | 1 | 0 | 0 | 1 | 0 | 0 | 0 | 0 | Resetting the keyboard |

| Checkpoint | Diagnostic LED Decoder | | | | | | | | Description |
|-------------------------|------------------------|----|----|----|--------------|----|----|-----|--|
| | 1 = On, 0=Off | | | | | | | | |
| | Upper Nibble | | | | Lower Nibble | | | | |
| | MSB | | | | | | | LSB | |
| | 8h | 4h | 2h | 1h | 8h | 4h | 2h | 1h | |
| LED | #7 | #6 | #5 | #4 | #3 | #2 | #1 | #0 | |
| 0x91h | 1 | 0 | 0 | 1 | 0 | 0 | 0 | 1 | Disabling the keyboard |
| 0x92h | 1 | 0 | 0 | 1 | 0 | 0 | 1 | 0 | Detecting the presence of the keyboard |
| 0x93h | 1 | 0 | 0 | 1 | 0 | 0 | 1 | 1 | Enabling the keyboard |
| 0x94h | 1 | 0 | 0 | 1 | 0 | 1 | 0 | 0 | Clearing keyboard input buffer |
| 0x96h | 1 | 0 | 0 | 1 | 0 | 1 | 1 | 0 | Reserved for keyboard |
| Mouse (only USB) | | | | | | | | | |
| 0x98h | 1 | 0 | 0 | 1 | 0 | 0 | 1 | 0 | Resetting the mouse |
| 0x99h | 1 | 0 | 0 | 1 | 0 | 0 | 1 | 1 | Detecting the mouse |
| 0x9Ah | 1 | 0 | 0 | 1 | 0 | 1 | 1 | 0 | Detecting the presence of mouse |
| 0x9Bh | 1 | 0 | 0 | 1 | 0 | 1 | 1 | 1 | Enabling the mouse |
| 0x9Ch | 1 | 0 | 0 | 1 | 0 | 0 | 1 | 0 | Reserved for mouse |
| Serial Port | | | | | | | | | |
| 0xA8h | 1 | 0 | 1 | 0 | 1 | 0 | 0 | 0 | Resetting the serial port |
| 0xA9h | 1 | 0 | 1 | 0 | 1 | 0 | 0 | 1 | Disabling the serial port |
| 0xAAh | 1 | 0 | 1 | 0 | 1 | 0 | 1 | 0 | Detecting the presence of the serial port |
| 0xABh | 1 | 0 | 1 | 0 | 1 | 0 | 1 | 1 | Clearing serial port buffer |
| 0xACh | 1 | 0 | 1 | 0 | 1 | 1 | 0 | 0 | Enabling serial port |
| 0xADh | 1 | 0 | 1 | 0 | 1 | 1 | 0 | 1 | Reserved for serial port |
| Fixed Media | | | | | | | | | |
| 0xB0h | 1 | 0 | 1 | 1 | 0 | 0 | 0 | 0 | Resetting fixed media device |
| 0xB1h | 1 | 0 | 1 | 1 | 0 | 0 | 0 | 1 | Disabling fixed media device |
| 0xB2h | 1 | 0 | 1 | 1 | 0 | 0 | 1 | 0 | Detecting presence of a fixed media device (SATA hard drive detection, and so forth) |
| 0xB3h | 1 | 0 | 1 | 1 | 0 | 0 | 1 | 1 | Enabling/configuring a fixed media device |
| 0xB4h | 1 | 0 | 1 | 1 | 0 | 1 | 0 | 0 | Reserved for fixed media |

Appendix C: LED Decoder

| Checkpoint | Diagnostic LED Decoder | | | | | | | | Description |
|--|------------------------|----|----|----|--------------|----|----|-----|---|
| | 1 = On, 0=Off | | | | | | | | |
| | Upper Nibble | | | | Lower Nibble | | | | |
| | MSB | | | | | | | LSB | |
| | 8h | 4h | 2h | 1h | 8h | 4h | 2h | 1h | |
| LED | #7 | #6 | #5 | #4 | #3 | #2 | #1 | #0 | |
| Removable Media | | | | | | | | | |
| 0xB8h | 1 | 0 | 1 | 1 | 1 | 0 | 0 | 0 | Resetting removable media device |
| 0xB9h | 1 | 0 | 1 | 1 | 1 | 0 | 0 | 1 | Disabling removable media device |
| 0xBAh | 1 | 0 | 1 | 1 | 1 | 0 | 1 | 0 | Detecting presence of a removable media device (SATA CDROM detection, and so forth) |
| 0xBC h | 1 | 0 | 1 | 1 | 1 | 1 | 0 | 0 | Enabling/configuring a removable media device |
| 0xBDh | 1 | 0 | 1 | 1 | 1 | 1 | 0 | 1 | Reserved for removable media device |
| Boot Device Selection (BDS) | | | | | | | | | |
| 0xD0 | 1 | 1 | 0 | 1 | 0 | 0 | 0 | 0 | Entered the Boot Device Selection phase (BDS) |
| 0xD1 | 1 | 1 | 0 | 1 | 0 | 0 | 0 | 1 | Return to last good boot device |
| 0xD2 | 1 | 1 | 0 | 1 | 0 | 0 | 1 | 0 | Setup boot device selection policy |
| 0xD3 | 1 | 1 | 0 | 1 | 0 | 0 | 1 | 1 | Connect boot device controller |
| 0xD4 | 1 | 1 | 0 | 1 | 0 | 1 | 0 | 0 | Attempt flash update boot mode |
| 0xD5 | 1 | 1 | 0 | 1 | 0 | 1 | 0 | 1 | Transfer control to EFI boot |
| 0xD6 | 1 | 1 | 0 | 1 | 0 | 1 | 1 | 0 | Trying to boot device selection |
| 0xDF | 1 | 1 | 0 | 1 | 1 | 1 | 1 | 1 | Reserved for boot device selection |
| Pre-EFI Initialization (PEI) Core | | | | | | | | | |
| 0xE0h | 1 | 1 | 1 | 0 | 0 | 0 | 0 | 0 | Entered Pre-EFI Initialization phase (PEI) |
| 0xE1h | 1 | 1 | 1 | 0 | 0 | 0 | 0 | 1 | Started dispatching early initialization modules (PEIM) |
| 0xE2h | 1 | 1 | 1 | 0 | 0 | 0 | 1 | 0 | Initial memory found, configured, and installed correctly |
| 0xE3h | 1 | 1 | 1 | 0 | 0 | 0 | 1 | 1 | Transfer control to the DXE Core |
| PEI Modules | | | | | | | | | |
| 0xF0h | 1 | 1 | 1 | 1 | 0 | 0 | 0 | 0 | Install PEIM for Platform Status Codes |
| 0xF1h | 1 | 1 | 1 | 1 | 0 | 0 | 0 | 1 | Detecting Platform Type |

| Checkpoint | Diagnostic LED Decoder | | | | | | | | Description |
|--|------------------------|----|----|----|--------------|----|----|-----|---|
| | 1 = On, 0=Off | | | | | | | | |
| | Upper Nibble | | | | Lower Nibble | | | | |
| | MSB | | | | | | | LSB | |
| | 8h | 4h | 2h | 1h | 8h | 4h | 2h | 1h | |
| LED | #7 | #6 | #5 | #4 | #3 | #2 | #1 | #0 | |
| 0xF2h | 1 | 1 | 1 | 1 | 0 | 0 | 1 | 0 | Early Platform Initialization |
| 0xF3h | 1 | 1 | 1 | 1 | 0 | 0 | 1 | 1 | PEI Modules initialized |
| Driver eXecution Environment (DXE) Core | | | | | | | | | |
| 0xE4h | 1 | 1 | 1 | 0 | 0 | 1 | 0 | 0 | Entered EFI driver execution phase (DXE) |
| 0xE5h | 1 | 1 | 1 | 0 | 0 | 1 | 0 | 1 | Started dispatching drivers |
| 0xE6h | 1 | 1 | 1 | 0 | 0 | 1 | 1 | 0 | Started connecting drivers |
| DXE Drivers | | | | | | | | | |
| 0xE7h | 1 | 1 | 1 | 0 | 1 | 1 | 0 | 1 | Waiting for user input |
| 0xE8h | 1 | 1 | 1 | 0 | 1 | 0 | 0 | 0 | Checking password |
| 0xE9h | 1 | 1 | 1 | 0 | 1 | 0 | 0 | 1 | Entering BIOS setup |
| 0xEAh | 1 | 1 | 1 | 0 | 1 | 1 | 0 | 0 | Flash Update |
| 0xEBh | 1 | 1 | 1 | 0 | 1 | 1 | 0 | 1 | Legacy Option ROM initialization |
| 0xECh | 1 | 1 | 1 | 0 | 1 | 0 | 0 | 0 | DXE Drivers initialized |
| 0xEDh | 1 | 1 | 1 | 0 | 1 | 0 | 0 | 1 | Transfer control to Boot Device Selection (BDS) |
| 0xEEh | 1 | 1 | 1 | 0 | 1 | 1 | 0 | 0 | Calling Int 19. One beep, unless silent boot is enabled. |
| 0xEFh | 1 | 1 | 1 | 0 | 1 | 1 | 0 | 1 | Unrecoverable boot failure |
| Pre-EFI Initialization Module (PEIM)/Recovery | | | | | | | | | |
| 0x30h | 0 | 0 | 1 | 1 | 0 | 0 | 0 | 0 | Crisis recovery initiated because of a user request |
| 0x31h | 0 | 0 | 1 | 1 | 0 | 0 | 0 | 1 | Crisis recovery initiated by software (corrupt flash) |
| 0x34h | 0 | 0 | 1 | 1 | 0 | 1 | 0 | 0 | Loading crisis recovery capsule |
| 0x35h | 0 | 0 | 1 | 1 | 0 | 1 | 0 | 1 | Handing off control to the crisis recovery capsule |
| 0x36h | 0 | 0 | 1 | 1 | 0 | 1 | 1 | 0 | Begin crisis recovery |
| 0x3Eh | 0 | 0 | 1 | 1 | 1 | 1 | 1 | 0 | No crisis recovery capsule detected |
| 0x3Fh | 0 | 0 | 1 | 1 | 1 | 1 | 1 | 1 | Crisis recovery capsule failed integrity check of capsule descriptors |

Appendix D: Getting Help

If you encounter an issue with your server system, follow these steps to obtain support:

1. Visit the following Intel support web page at http://www.intel.com/p/en_US/support/server/. This web page provides 24x7 support when you need it to get the latest and most complete technical support information on all Intel® Enterprise Server and Storage Platforms. Information available at the support site includes:
 - Latest BIOS, firmware, drivers, and utilities.
 - Product documentation, installation and quick start guides.
 - Full product specifications, technical advisories, and errata.
 - Compatibility documentation for memory, hardware add-in cards, chassis support matrix, and operating systems.
 - Server and chassis accessory parts list for ordering upgrades or spare parts.
 - A searchable knowledge base to search for product information throughout the support site.
2. If you are still unable to obtain a solution to your issue, send an email to Intel®'s technical support center using the online form available at:
<http://supportmail.intel.com/scripts-emf/welcome.aspx>.
3. Lastly, you can contact an Intel® support representative using one of the support phone numbers available at http://www.intel.com/p/en_US/support/contact/phone (charges may apply). Intel® customer support suggests filling out the issue report form available in Appendix E: Intel® Server Issue Report Form to better service the issue.

Intel® also offers Channel Program members around-the-clock 24x7 technical phone support on Intel® server boards, server chassis, server RAID controller cards, and Intel® Server Management at <http://www.intel.com/reseller/>.

Note: You will need to log in to the Reseller site to obtain the 24x7 number.

Warranty Information

To obtain warranty information, visit the following Intel® website:
<http://www.intel.com/support/motherboards/server/sb/cs-010807.htm>.

Appendix E: Intel® Server Issue Report Form

Issue Report Form (Rev 3.6)

Note: Filling out this form completely is required for any escalation.

Customer Contact Information:

Customer Support Case#:

Intel® Server Board or System:

(Example: S1600JP, R1304JP4GS)

Server Chassis:

(Example R1000JP. If third-party chassis used, indicate make and model.)

Base Board Information: (some information may be found by accessing BIOS and going through the Server Management menu > System Information)

Baseboard PBA/TA/AA # (Example: 123456-789):

- can be found on the white sticker label on the baseboard.

System BIOS Version:

Intel® Remote Management Module Firmware Version (if applicable):

Intel® Management Module BMC Revision (if applicable):

BMC/mBMC Version:

FRU/SDR Version:

HSC Version:

Has the latest BIOS been tried? (Yes/No):

Has the latest BMC/mBMC been tried? (Yes/No):

Has the latest IMM BMC been tried? (Yes/No):

Has the latest RMM Firmware been tried? (Yes/No):

Has the latest FRU/SDR been tried? (Yes/No):

Has the latest HSC been tried? (Yes/No):

Processor information:

| | Type | Speed | Spec | Thermal Solution |
|-------------|------|-------|------|------------------|
| Processor 1 | | | | |
| Processor 2 | | | | |

Appendix E: Intel® Server Issue Report Form

| | Type | Speed | Spec | Thermal Solution |
|-------------|------|-------|------|------------------|
| Processor 3 | | | | |
| Processor 4 | | | | |

Thermal solution (Heatsink) examples:
(1U, Passive w/air ducting, Active w/fan, and so on.)

Memory:

| Manufacturer | Part Number | DRAM Part Number | On Intel® tested list? |
|--------------|-------------|------------------|------------------------|
| | | | |
| | | | |
| | | | |
| | | | |
| | | | |
| | | | |
| | | | |

Add-in adapters (Example: NICs, Management Adapters, Serial Expansion Cards, PCI-Express* Adapters, RAID Controllers, SCSI Controllers, and so on):

| Type | Slot | Manufacturer | Model | Firmware |
|------|------|--------------|-------|----------|
| | | | | |
| | | | | |
| | | | | |

Other third part hardware (Example: KVM, Chassis, and so on):

| Description/Use | Manufacturer | Model | Firmware |
|-----------------|--------------|-------|----------|
| | | | |
| | | | |

Storage Devices (Example: SCSI, SATA, SAS, USB, Tape, and so on):

| Manufacturer | Model | Type | Size | Firmware | In Hot Swap Bay? |
|--------------|-------|------|------|----------|------------------|
| | | | | | |
| | | | | | |
| | | | | | |
| | | | | | |
| | | | | | |

Operating System Information (Example: RedHat* Enterprise Linux, Microsoft Windows Server 2003*, Service pack 1, OEM CD):

Manufacturer:

Version:

Language version (English, Arabic, and Chinese (Simplified)):

Service Pack Level or Kernel Revision:

Distribution (OEM/Retail):

Intel® RAID Controller: (Example SRCU42E)

RAID controller part number (PBA number):

RAID controller firmware version:

Has the latest RAID firmware been tried? (Yes/No):

RAID driver version:

Has the latest RAID driver been tried? (Yes/No):

RAID volumes configuration (disks & RAID level):

RAID volume use (Boot device/Data Volume):

Is BBU (Battery Backup Unit) installed? (Yes/No):

BBU part number:

Detailed description of issue:

Appendix E: Intel® Server Issue Report Form

Troubleshooting tried:

Steps to replicate the issue:

Issue impact statements:

Do you have any potential Intel® system, or component purchases that this issue is holding up? If yes, please provide a brief description below.

Do you have systems already purchased that are not being delivered to your customers because of this issue? If yes, please provide a brief description below.

Have you returned systems or components to your place of purchase because of this issue? If yes, please provide a brief description below.

*All other brands and names are property of their respective owners.