

Intel® Server System R1304BTSSFAN Quick Start User's Guide

Thank you for buying an Intel® Server System. The following information will help you assemble your Intel® Server System R1304BTSSFAN and install components.

This guide and other supporting documents are located on the web at <http://www.intel.com/support/motherboards/server>

If you are not familiar with ESD (Electrostatic Discharge) procedures used during system integration, please see the Intel® Server System R1304BTSSFAN Service Guide, available on the Intel® Server Deployment Toolkit CD or at <http://www.intel.com/support/motherboards/server>

Read all cautions and warnings first before starting your server system integration.

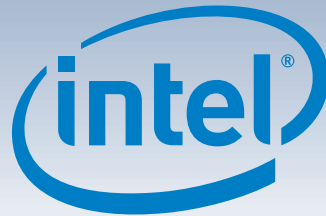
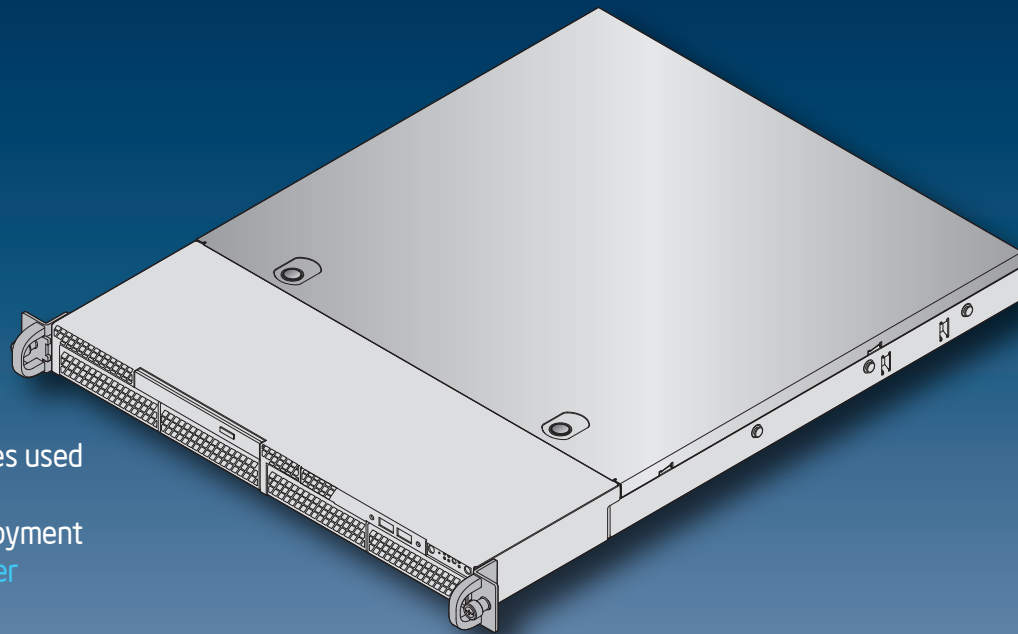

Minimum Hardware Requirements

To avoid integration difficulties and possible damage to your system, make sure you have components from each category below.

- **Heat Sink:**
 - 1U passive heat sink.
- **Memory:**
 - Memory Type: Minimum of one 1 GB, 240-pin DDR3 1066/1333 MHz UDIMM.
- **Hard Disk Drives:**
 - SATA
- **Power:**
 - Minimum of 250W with 3A of standby current, which meets the SSI EPS 12V specification.

Tools Required

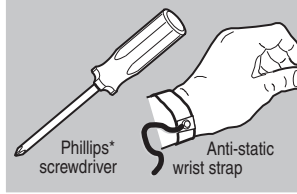

Fastener Identification Guide

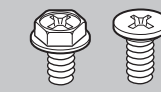

1 Preparing the Chassis

Observe normal ESD (Electrostatic Discharge) procedures.



Place your Intel® Server Chassis on a flat anti-static surface to perform the following integration procedures. Always touch the chassis frame first, before reaching inside to make server board connections or to install components.

2 Remove Top Cover

- Remove the security screw.
- Depress the latch.
- Slide cover back and lift upward.

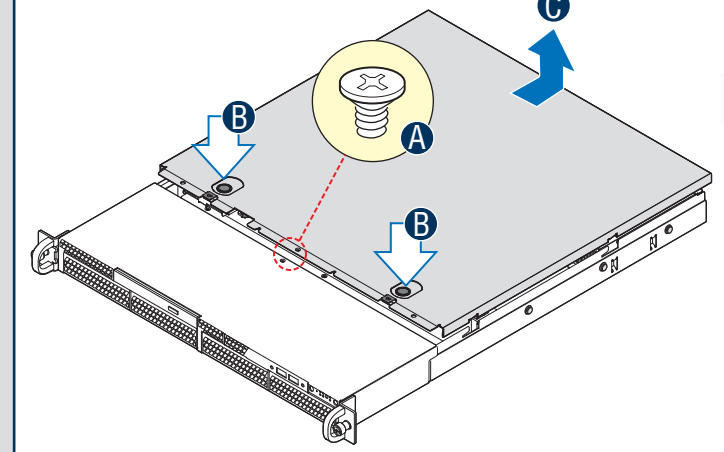

3 Remove Air Duct

- Removing air duct by lifting straight up.

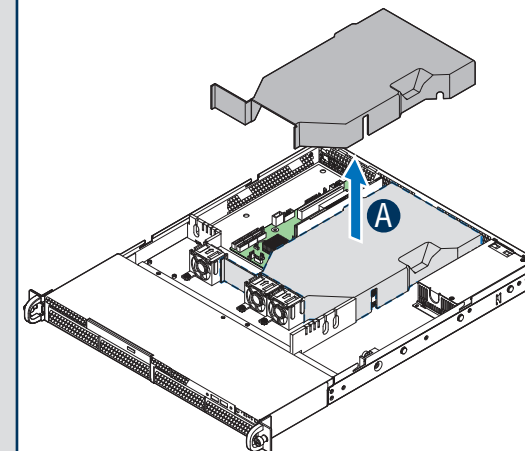

4 Remove Add-in Card Riser Assembly

- Grasp riser with both hands and pull straight up to release riser card connector from server board socket.

CAUTION: Place the riser assembly upside-down to avoid damage to the riser card connector.

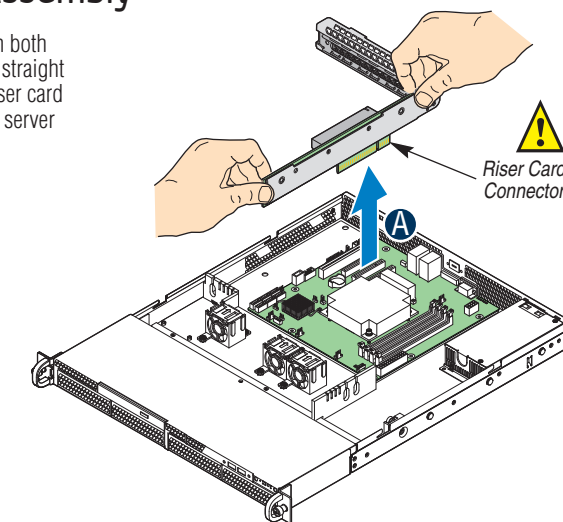

IMPORTANT!

Before proceeding further, do the following:

Check your Intel® Server System for disconnected or loose cables and components that may have occurred during shipping.

Warning

Read all caution and safety statements in this document before performing any of the instructions. Also see the Intel® Server Board and Server Chassis Safety Information document at: <http://support.intel.com/support/motherboards/server/sb/cs-010770.htm> for complete safety information.

Warning

Installation and service of this product should only be performed by qualified service personnel to avoid risk of injury from electrical shock or energy hazard.

Caution

Observe normal ESD (Electrostatic Discharge) procedures during system integration to avoid possible damage to server board and/or other components.

Caution

Low Power Unit, Please Check Power Budget Tool For Supported Configuration.

Intel is a registered trademark of Intel Corporation or its subsidiaries in the United States and other countries. Other names and brands may be claimed as the property of others. Copyright © 2011, Intel Corporation. All rights reserved.

G20493-001



5 Install the Processor

Cautions:

- When removing the protective cover, DO NOT TOUCH the gold socket wires.
- To avoid damage, DO NOT DROP the cover onto the socket wires or components.
- When unpacking a processor, hold by the edges only to avoid touching the gold contact wires.

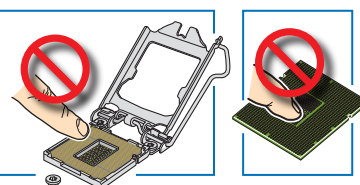

A. Open the Socket Lever

- Push the lever handle down and away from the socket to release it.

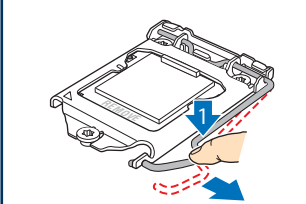

B. Open the Load Plate

Open the load plate as shown.

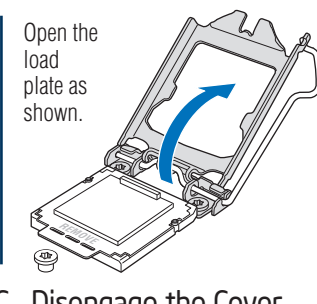

D. Remove the Cover

Carefully lift the cover straight up as shown.

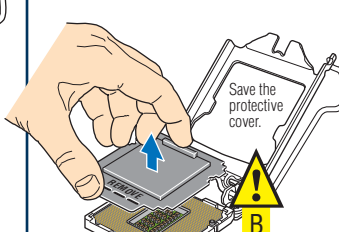

F. Install the Processor

CAUTION: The underside of the processor has components that may damage the socket wires if installed improperly. Processor must align correctly with the socket opening before installation. DO NOT DROP processor into socket!

- Orient the processor with the socket so that the processor cutouts match the two socket pins.
- Note location of gold key at corner of processor.

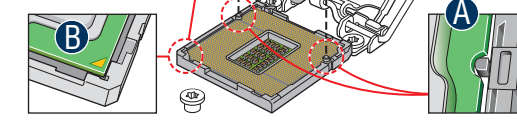

G. Close the Load Plate

Carefully lower the load plate over the processor.

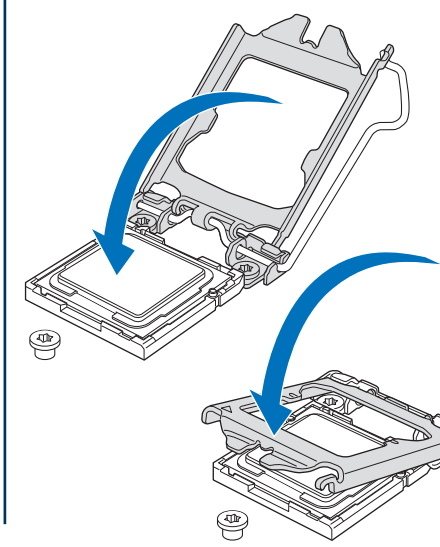

H. Engage the Load Plate

- Make sure the front edge of the load plate slides under the shoulder screw as the lever is lowered.
- Close the load plate locking lever.

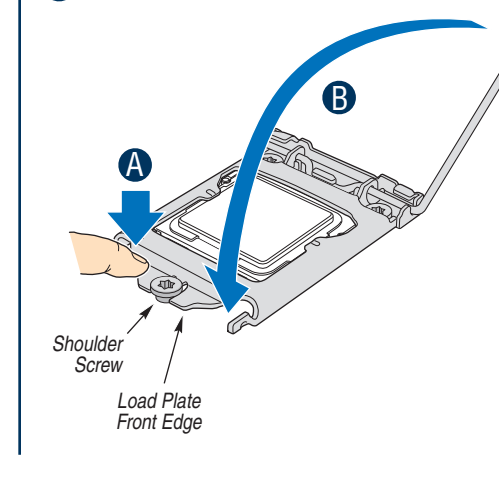

I. Latch the Locking Lever

- Push down on the locking lever.
- Slide the tip of the lever under the notch in the load plate. Make sure the lever is securely latched.

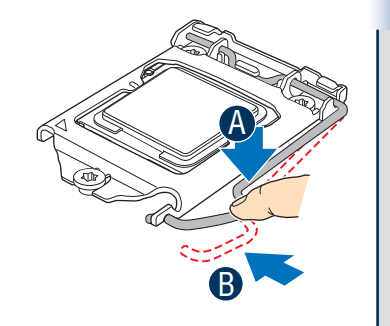

6 Install Heat Sink

- Get heat sink from the shipping position.
- Remove the protective film on the TIM if present.
- Align heat sink fins to the front and back of the chassis for correct airflow. Airflow goes from front-to-back of chassis.
- Using a #2 Phillips® screwdriver, finger-tighten each fastener diagonally, according to the numbers shown.
- Securely re-tighten each fastener again in the same order as performed in Step E.

CAUTION: The heat sink has thermal interface material (TIM) on the underside of it. Use caution so that you do not damage the thermal interface material. Use gloves to avoid sharp edges.

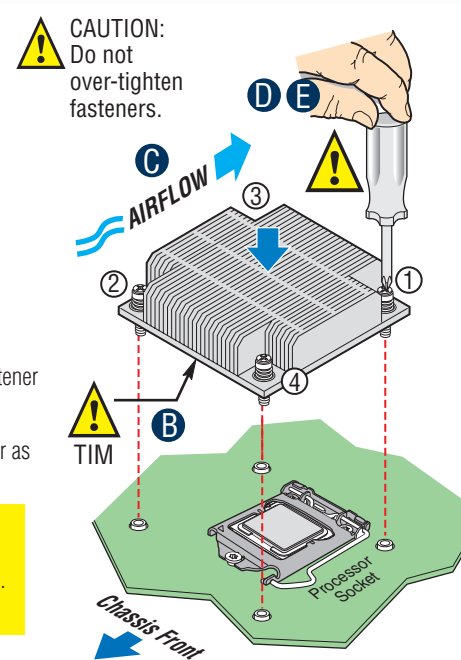

7 Install DIMM Memory Modules

DDR3 DIMM Memory Identification:

- CAUTION:** Observe normal ESD (Electrostatic Discharge) procedures to avoid possible damage to system components.
- This server board supports up to 4 DDR3 1066/1333 ECC UDIMM.

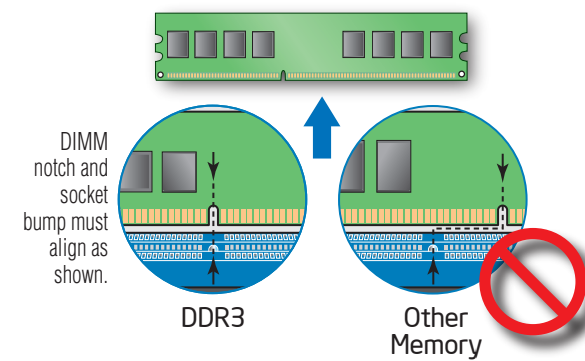

Memory Configurations and Population Order:

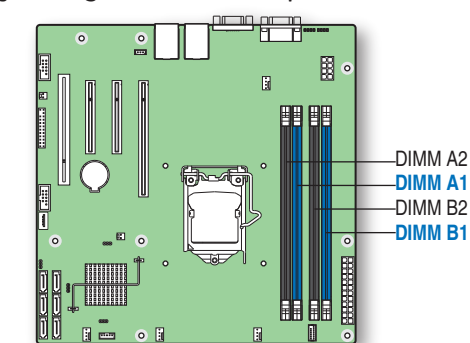

Memory Type: Minimum of one 1 GB, DDR3 1066/1333 MHz ECC UDIMM.
Note: For additional memory configurations, see the Intel® Server Board S1200BTS Technical Product Specification at: <http://www.intel.com/support/motherboards/server>
Memory sizing and configuration is supported only for qualified DIMMs approved by Intel®. For a list of supported memory, see the tested memory list at <http://serverconfigurator.intel.com/default.aspx>

To Install DIMMs:

- CAUTION:** Avoid touching contacts when handling or installing DIMMs.
- Open both DIMM socket levers.
- Note location of alignment notch.
- Insert DIMM making sure the connector edge of the DIMM aligns correctly with the slot.
- Push down firmly on the DIMM until it snaps into place and both levers close.
- IMPORTANT!** Visually check that each latch is fully closed and correctly engaged with each DIMM edge slot.

