

Intel® Server Chassis P4000S Family

Technical Product Specification

Intel order number G22850-005

Revision 1.4

March, 2012

Enterprise Platforms and Services Marketing

Revision History

Date	Revision Number	Modifications
July, 2010	0.5	Initial release.
December, 2010	1.0	Updated the document.
March, 2011	1.1	Added P4304XXSHCN related features.
May, 2011	1.2	Added acoustic data for P4304XXSFCN and P4304XXSHCN in section 9.3.
June, 2011	1.3	Updated figure in section 5.1.2 – Board Layout.
March, 2012	1.4	Added P4304XXSFEN, P4304XXSFDR, P4304XXSHEN and P4304XXSHDR related features.

Disclaimers

Information in this document is provided in connection with Intel® products. No license, express or implied, by estoppel or otherwise, to any intellectual property rights is granted by this document. Except as provided in Intel's Terms and Conditions of Sale for such products, Intel assumes no liability whatsoever, and Intel disclaims any express or implied warranty, relating to sale and/or use of Intel products including liability or warranties relating to fitness for a particular purpose, merchantability, or infringement of any patent, copyright or other intellectual property right. Intel products are not intended for use in medical, lifesaving, or life sustaining applications. Intel may make changes to specifications and product descriptions at any time, without notice.

Designers must not rely on the absence or characteristics of any features or instructions marked "reserved" or "undefined." Intel reserves these for future definition and shall have no responsibility whatsoever for conflicts or incompatibilities arising from future changes to them.

This document contains information on products in the design phase of development. Do not finalize a design with this information. Revised information will be published when the product is available. Verify with your local sales office that you have the latest datasheet before finalizing a design.

The Intel® Server Chassis P4000S Family may contain design defects or errors known as errata which may cause the product to deviate from published specifications. Current characterized errata are available on request.

Intel Corporation server baseboards contain a number of high-density VLSI and power delivery components that need adequate airflow to cool. Intel's own chassis are designed and tested to meet the intended thermal requirements of these components when the fully integrated system is used together. It is the responsibility of the system integrator that chooses not to use Intel developed server building blocks to consult vendor datasheets and operating parameters to determine the amount of air flow required for their specific application and environmental conditions. Intel Corporation cannot be held responsible if components fail or the server board does not operate correctly when used outside any of their published operating or non-operating limits.

Intel, Pentium, Itanium, and Xeon are trademarks or registered trademarks of Intel Corporation.

*Other brands and names may be claimed as the property of others.

Copyright © Intel Corporation 2012

Table of Contents

1. Product Overview	1
1.1 Intel® Server Chassis P4000S Family Design Features.....	1
1.2 Intel® Server Chassis P4304XXSFCN Views.....	3
1.3 Intel® Server Chassis P4304XXSHCN Views	4
1.4 Intel® Server Chassis P4304XXSFEN Views	5
1.5 Intel® Server Chassis P4304XXSHEN Views	6
1.6 Intel® Server Chassis P4304XXSFDR Views.....	7
1.7 Intel® Server Chassis P4304XXSHDR Views	8
1.8 Chassis Security	8
1.9 I/O Panel.....	9
1.10 Front Bezel Features.....	9
1.11 Front Panel Overview.....	10
1.12 Back Panel Overview	11
1.13 Standard Fixed Drive Trays.....	12
1.14 4x3.5" Hot-Swap Hard Disk Drive Cage	12
1.14.1 3.5" Hot-swap Hard Drive Carrier	13
1.15 Peripheral Bays.....	13
2. Chassis Power Sub-system	15
2.1 365W Power Supply.....	15
2.1.1 Mechanical Overview	15
2.1.2 365W Power Supply Output Wire Harness.....	17
2.1.3 Temperature Requirements.....	19
2.1.4 AC Input Requirements	19
2.1.5 Efficiency	21
2.1.6 DC Output Specification	22
2.1.7 Protection Circuits	27
2.1.8 Control and Indicator Functions.....	28
2.2 550W Power Supply.....	29
2.2.1 Mechanical Overview	29
2.2.2 Temperature Requirements.....	33
2.2.3 AC Input Requirements	34
2.2.4 Efficiency.....	36
2.2.5 DC Output Specification	36
2.2.6 Protection Circuits	41
2.2.7 Control and Indicator Functions.....	42
2.3 460W Power Supply.....	43
2.3.1 Mechanical Overview	44
2.3.2 AC Input Requirements	46
2.3.3 Efficiency.....	48

2.3.4	DC Output Specification	48
2.3.5	Protection Circuits	52
2.3.6	Control and Indicator Functions.....	53
2.3.7	Thermal CLST	56
2.3.8	Power Supply Diagnostic “Black Box”	56
2.3.9	Firmware Uploader.....	56
2.4	Lower Current Common Redundant Power Distribution Board (PDB)	56
2.4.1	Mechanical Overview	57
2.4.1.2	DC/DC converter cooling.....	58
2.4.2	DC Output Specification	58
2.4.3	Protection Circuits	66
2.4.4	PWOK (Power OK) Signal.....	67
2.4.5	PSON Signal	68
2.4.6	PMBus*	68
3.	Chassis Cooling	69
3.1	Cooling solution for Intel® Server Board S1200BT Series.....	69
3.2	Cooling solution for Intel® Server Board S2400SC	70
3.3	Fan Control	71
3.4	Fan Header Connector Descriptions	71
4.	Standard Front Panel	72
4.1	Front Panel Overview.....	72
4.2	Front Panel Features.....	72
4.3	Common Front Panel Placement.....	73
4.3.1	Common Front Panel LED Functionality.....	73
4.4	Common Front Panel Connector List and Pinouts.....	74
4.4.1	Pinouts.....	74
5.	4x3.5” Hot-Swap Back Plane (HSBP)	76
5.1	Overview	76
5.1.1	Key Features.....	76
5.1.2	Board Layout.....	76
5.2	4x 3.5" HSBP Functional Description	78
5.2.1	4x3.5” HSBP Microcontroller	78
5.2.2	SGPIO Functionality.....	79
5.2.3	I2C Functionality	79
5.2.4	SATA 6X Mode Jumper Functionality	80
5.2.5	HSBP LED Functionality	81
5.3	4x3.5” HSBP Connector List and Pinouts.....	81
5.3.1	Pinouts.....	82
5.4	4x3.5” HSBP Cabling Requirements	82
6.	System Interconnection	84
6.1	Chassis Internal Cables	84

6.1.1	Front Panel Cable	84
6.1.2	Intrusion Switch cable	84
6.1.3	USB Cable	84
6.1.4	SATA Power Adapter Cable	85
6.1.5	SATA cable for HDDs/ODD	85
6.1.6	Mini SAS(MB) to 4pcs 7Pin SATA Cable with SGPIO Cable	86
6.1.7	Mini SAS(MB) to 4pcs 7Pin SATA Cable	86
6.1.8	I2C Cable (5pin(HSBP)--3pin(MB))	87
6.1.9	SGPIO Cable	87
7.	System-Compatible Intel® Server Boards	88
8.	Reliability, Serviceability, and Availability	89
8.1	Mean Time between Failure	89
8.2	Serviceability	91
9.	Environmental Limits	92
9.1	System Office Environment	92
9.2	System Environmental Testing	92
9.3	Intel® Server Chassis P4000S Family Acoustic Level	93
9.3.1	Intel® Server Chassis P4000S Family with Intel® Server Board S1200BTL	93
9.3.2	Intel® Server Chassis P4000S Family with Intel® Server Board S1200BTS	94
9.3.3	Intel® Server Chassis P4000S Family with Intel® Server Board S2400SC	94
10.	Product Regulatory Compliance	96
	Appendix A: Integration and Usage Tips	97
	Glossary	98

List of Figures

Figure 1. Internal Chassis View of Intel® Server Chassis P4304XXSFCN	3
Figure 2. Internal Chassis View of Intel® Server Chassis P4304XXSHCN	4
Figure 3. Internal Chassis View of Intel® Server Chassis P4304XXSFEN	5
Figure 4. Internal Chassis View of Intel® Server Chassis P4304XXSHEN	6
Figure 5. Internal Chassis View of Intel® Server Chassis P4304XXSFDR	7
Figure 6. Internal Chassis View of Intel® Server Chassis P4304XXSHDR	8
Figure 7. ATX 2.2 I/O Aperture	9
Figure 8. Front Closed Chassis View with Front Bezel for Fixed Hard Drives Configuration	9
Figure 9. Front Closed Chassis View with Front Bezel for Hot-swap Hard Drives Configuration	10
Figure 10. Front Panel Controls and Indicators	11
Figure 11. Back Panel Layout (with Fixed Power Supply)	11
Figure 12. Back Panel Layout (with Hot-swap Power Supply)	12
Figure 13. Fixed Drive Tray	12
Figure 14. 4x3.5" Hot-Swap Hard Disk Drive Cage	13
Figure 15. 3.5" hot-swap hard drive carrier with 2.5" HDD Interface Bracket	13
Figure 16. Tool-less Rails Mounting 5.25-inch CD-ROM Drive	14
Figure 17. Mechanical Drawing for 365W Power Supply Enclosure	16
Figure 18. Output Cable Harness for 365W Power Supply	17
Figure 19. Differential Noise test setup	25
Figure 20. Output Voltage Timing	26
Figure 21. Turn On/Off Timing (Power Supply Signals)	27
Figure 22. PSON# Required Signal Characteristic	29
Figure 23. Mechanical Drawing for 550W Power Supply Enclosure	30
Figure 24. Output Cable Harness for 550W Power Supply	31
Figure 25. Differential Noise test setup	39
Figure 26. Output Voltage Timing	40
Figure 27. Turn On/Off Timing (Power Supply Signals)	41
Figure 28. PSON# Required Signal Characteristic	43
Figure 29. Power Supply Outline Drawing	44
Figure 30. Differential Noise test setup	51
Figure 31. Turn On/Off Timing (Power Supply Signals)	52
Figure 32. PSON# Required Signal Characteristic	54
Figure 33. Implementation of the Power Ok Circuits	55
Figure 34. Outline Drawing	57
Figure 35. Airflow Diagram	58
Figure 36. Differential Noise test setup	66
Figure 37. Active Heat Sink and Chassis Rear Fan in Intel® Server Chassis P4304XXSFCN ...	69

Figure 38. Chassis System Fans Default loaction in Intel® Server Chassis P4304XXSFEN70

Figure 39. Chassis System Fans to support full length card in Intel® Server Chassis P4304XXSFEN.....70

Figure 40. Front Panel overview72

Figure 41. Common Front Panel LED/Button Arrangement.....73

Figure 42. 4x3.5” HSBP Board Layout77

Figure 43. 4x 3.5" HSBP I2C Connectivity.....80

Figure 44. Chassis Front Panel Cable.....84

Figure 45. Intrusion Switch Cable.....84

Figure 46. USB Cable Drawing85

Figure 47. SATA Power Adapter Cable85

Figure 48. SATA cable for HDDs (450mm)85

Figure 49. Mini SAS(MB) to 4pcs 7Pin SATA cable with SGPIO Cable86

Figure 50. Mini SAS(MB) to 4pcs 7Pin SATA Cable.....86

Figure 51. I2C Cable (5pin to 3pin)87

Figure 52. SGPIO Cable87

List of Tables

Table 1. Intel® Server Chassis P4000S family Features	1
Table 2. 365W Power Supply Cable Lengths	18
Table 3. P1 Main Power Connector.....	18
Table 4. P2 Processor#1 Power Connector	18
Table 5. Peripheral Power Connectors.....	19
Table 6. SATA Power Connector	19
Table 7. Thermal Requirements.....	19
Table 8. Power Factor Requirements for Computer Servers	20
Table 9. AC Input Voltage Range.....	20
Table 10. AC Line Holdup Time	20
Table 11. AC Line Sag Transient Performance	21
Table 12. AC Line Surge Transient Performance	21
Table 13. Silver Efficiency Requirement.....	21
Table 14. Over Voltage Protection Limits	22
Table 15. Loading Conditions.....	22
Table 16. Voltage Regulation Limits.....	23
Table 17. Transient Load Requirements	23
Table 18. Capacitive Loading Conditions	23
Table 19. Ripples and Noise	24
Table 20. Output Voltage Timing.....	25
Table 21. Turn On/Off Timing.....	26
Table 22. Over Voltage Protection (OVP) Limits	28
Table 23. PSON# Signal Characteristic	28
Table 24. PWOK Signal Characteristics.....	29
Table 25. Power Supply Cable Lengths	31
Table 26. P1 Main Power Connector.....	32
Table 27. P2 Processor#1 Power Connector	32
Table 28. P3 Processor#1 Power Connector	33
Table 29. Peripheral Power Connectors.....	33
Table 30. SATA Power Connector	33
Table 31. Thermal Requirements.....	34
Table 32. Power Factor Requirements for Computer Servers	34
Table 33. AC Input Voltage Range.....	34
Table 34. AC Line Holdup time	35
Table 35. AC Line Sag Transient Performance	35
Table 36. AC Line Surge Transient Performance	35
Table 37. Silver Efficiency Requirement.....	36
Table 38. Over Voltage Protection Limits	36

Table 39. Loading Conditions.....	37
Table 40. Voltage Regulation Limits.....	37
Table 41. Transient Load Requirements	37
Table 42. Capacitive Loading Conditions	38
Table 43. Ripples and Noise	39
Table 44. Output Voltage Timing.....	39
Table 45. Turn On/Off Timing.....	40
Table 46. Over Current Limits	41
Table 47. PSON# Signal Characteristic	42
Table 48. PWOK Signal Characteristics	43
Table 49. DC Output Selector	44
Table 50. LED Characteristics.....	45
Table 51. LED Indicator States	45
Table 52. Environmental Requirements	46
Table 53. AC Input Voltage Range.....	47
Table 54 AC Line Sag Transient Performance	48
Table 55. AC Line Surge Transient Performance	48
Table 56. Gold Efficiency Requirement	48
Table 57. Minimum Load Ratings.....	48
Table 58. Voltage Regulation Limits.....	49
Table 59. Transient Load Requirements	49
Table 60. Capacitive Loading Conditions	50
Table 61. Ripples and Noise	51
Table 62. Timing Requirements	51
Table 63. Over Current Protection.....	53
Table 64. Over Voltage Protection (OVP) Limits	53
Table 65. PSON# Signal Characteristic	54
Table 66. PWOK Signal Characteristics	54
Table 67. SMBAlert# Signal Characteristics.....	56
Tabel 68. Thermal Requirements.....	58
Table 69. Input Connector and Pin Assignment Diagrams	59
Table 70. PDB Cable Length.....	59
Table 71. P1 Baseboard Power Connector	60
Table 72. P0 Processor Power Connector	60
Table 73. P1 Processor Power Connector	60
Table 74. Power Signal Connector.....	61
Table 75. Aux baseboard power connector	61
Table 76. P8, P9, P10, P11 Legacy Peripheral Power Connectors	61
Table 77. P7 Legacy Peripheral Power Connectors	61
Table 78. SATA Peripheral Power Connectors.....	62
Table 79. Remote Sense Connection Points.....	62

Table 80. Remote Sense Requirements.....	62
Table 81. 12V Rail Distribution.....	63
Table 82. Hard Drive 12V rail configuration options	63
Table 83. DC/DC Converters Load Ratings.....	64
Table 84. 5VSB Loading	64
Table 85. Voltage Regulation Limits.....	64
Table 86. Transient Load Requirements	64
Table 87. Capacitive Loading Conditions	65
Table 88. Ripple and Noise	65
Table 89. Output Voltage Timing.....	66
Table 90. PDB Over Current Protection Limits/240VA Protection.....	67
Table 91. Over Voltage Protection (OVP) Limits	67
Table 92. System PWOK Requirements	68
Table 93. PDB addressing	68
Table 94. Front Panel LED Functionality.....	73
Table 95. Connectors for Boards	74
Table 96. Pinouts Signal Description.....	74
Table 97. Chassis Intrusion Pin-out.....	75
Table 98. 4x3.5" HSBP Microcontroller Pinouts	78
Table 99. 4x3.5" HSBP SATA 6X Mode Host Jumper Block.....	80
Table 100. Romley LED Functionality	81
Table 101. HDD Activity LED Functionality	81
Table 102. 4x3.5" HSBP Connector List.....	81
Table 103. 4x3.5" HSBP SGPIO Connector Pinouts	82
Table 104. 4x3.5" HSBP I2C(In) Connector Pinouts.....	82
Table 105. 4x3.5" HSBP I2C (Out) Connector List	82
Table 106. 4x3.5" HSBP Power Connector Pinouts	82
Table 107. System-Compatible Intel® Server Boards	88
Table 108. Calculated Mean Time Between Failure – P4304XXSFCN and P4304XXSHCN	89
Table 109. Calculated Mean Time Between Failure – P4304XXSFEN and P4304XXSHEN	90
Table 110. Calculated Mean Time Between Failure – P4304XXSFDR and P4304XXSHDR	90
Table 111. Calculated Mean Time Between Failure – P4304XXSFDN and P4304XXSHDN	91
Table 112. Maximum Maintenance Procedure Times.....	91
Table 113. System Office Environment Summary	92
Table 114. Test Conditions at Acoustic Lab	93
Table 115. System Configurations	93
Table 116. Declared Acoustic Data of Intel® Server Chassis P4000S family with Intel® Server Board S1200BTL.....	93
Table 117. Test Conditions at Acoustic Lab	94
Table 118. System Configurations	94

Table 119. Declared Acoustic Data of Intel® Server Chassis P4000S family with Intel® Server Board S1200BTS.....94

Table 120. Test Conditions at Acoustic Lab94

Table 121. System Configurations95

Table 122. Declared Acoustic Data of Intel® Server Chassis P4000S family with Intel® Server Board S2600SC95

<This page is intentionally left blank.>

1. Product Overview

The Intel® Server Chassis P4000S family is a 4U pedestal, 22” length server chassis. Intel® Server Chassis P4304XXSFCN and P4304XXSHCN are designed to support Intel® Server Board S1200BTL, S1200BTS. Intel® Server Chassis P4304XXSFEN, P4304XXSFDR, P4304XXSHEN and P4304XXSHDR are designed to support Intel® Server Board S2400SC. This chapter provides a high-level overview of the chassis features. Greater detail for each major chassis component or feature is provided in the following chapters.

1.1 Intel® Server Chassis P4000S Family Design Features

The Intel® Server Chassis P4000S family is designed to address the entry-level market. The Intel® Server Chassis P4000S Family make extensive use of tool-less hardware features and, depending on configuration and upgrade features, provides redundant power supply and hot swappable hard drives capability. The Intel® Server Chassis P4000S family comes with the following configurations:

- P4304XXSFCN – one 365W non-redundant PSU, one fixed 92x38mm rear system fan and up to four 3.5” fixed hard drives
- P4304XXSHCN – 365W non-redundant PSU and one fixed 92x38mm rear system fan up to four 3.5” hot-swap hard drives
- P4304XXSFEN –one 550W non-redundant PSU, two fixed 92x32mm system fans and up to four 3.5” fixed hard drives
- P4304XXSHEN –one 550W non-redundant PSU, two fixed 92x32mm system fans and up to four 3.5” hot-swap hard drives
- P4304XXSFDR –two 460W redundant PSU, two fixed 92x32mm system fans and up to four 3.5” fixed hard drives
- P4304XXSHDR – two 460W redundant PSU, two fixed 92x32mm system fans and up to four 3.5” hot-swap hard drives
- P4304XXSFDN – one 460W hot-swap PSU, two fixed 92x32mm system fans and up to four 3.5” fixed hard drives
- P4304XXSHDN – one 460W hot-swap PSU, two fixed 92x32mm system fans and up to four 3.5” hot-swap hard drives

The following table summarizes the features for all chassis combinations.

Table 1. Intel® Server Chassis P4000S family Features

Configuration	P4304XXSFCN	P4304XXSHCN	P4304XXSFEN	P4304XXSHEN
Intel® Server Board Support	Intel® Server Board S1200BTL Intel® Server Board S1200BTS	Intel® Server Board S1200BTL	Intel® Server Board S2400SC	
Power	365W non-redundant power supply with integrated cooling fan		550W non-redundant power supply with integrated cooling fan.	

Configuration	P4304XXSFCN	P4304XXSHCN	P4304XXSFEN	P4304XXSHEN
System Cooling	One 92x38mm fixed system rear fan		Two 92x32mm fixed system fans.	
Peripherals Bays	Three (3) half height 5-1/4" bays for optical devices.			
Drive Bays	Includes one fixed drive bay. Supports up to four fixed hard drives.	Includes one 4x3.5" hot-swap hard drive cage. Supports up to four hot-swap hard drives.	Includes one fixed drive bay. Supports up to four fixed hard drives.	Includes one 4x3.5" hot-swap hard drive cage. Supports up to four hot-swap hard drives.
Expansion Slots	Up to Six (6) PCI cards (depends on board features)			
Front Panel	Power Button with LED, Reset Button, NMI Button, ID Button with LED, Four NIC LEDs, Hard drive activity LED, System status LED, two USB ports, Optional front serial port/VGA port			
Appearance	Color: Cosmetic black (GE 701 or equivalent), service Intel blue, hot swap Intel green. Support for Intel standard front panel or LCD			
Dimensions Pedestal with Front Bezel	17.24 in (438 mm) x 6.81 in (173mm) x 22.05 in (560 mm) (Height X Width X Depth)			
Optional Accessory Kits	Zephyr flash storage, RMM4-lite modules, TPM module, dedicated NIC module			
Configuration	P4304XXSFDR	P4304XXSHDR	P4304XXSFDN	P4304XXSHDN
Intel® Server Board Support	Intel® Server Board S2400SC			
Power	Two 460W redundant power supply with integrated cooling fan		One 460W hot-swap power supply with integrated cooling fan	
System Cooling	Two 92x32mm fixed system fans			
Peripherals Bays	Three (3) half height 5-1/4" bays for optical devices.			
Drive Bays	Includes one fixed drive bay. Supports up to four fixed hard drives.	Includes one 4x3.5" hot-swap hard drive cage. Supports up to four hot-swap hard drives.	Includes one fixed drive bay. Supports up to four fixed hard drives.	Includes one 4x3.5" hot-swap hard drive cage. Supports up to four hot-swap hard drives.
Expansion Slots	Up to Six (6) PCI cards (depends on board features)			
Front Panel	Power Button with LED, Reset Button, NMI Button, ID Button with LED, Four NIC LEDs, Hard drive activity LED, System status LED, two USB ports, Optional front serial port/VGA port			
Appearance	Color: Cosmetic black (GE 701 or equivalent), service Intel blue, hot swap Intel green. Support for Intel standard front panel or LCD			
Dimensions Pedestal with Front Bezel	17.24 in (438 mm) x 6.81 in (173mm) x 22.05 in (560 mm) (Height X Width X Depth)			
Optional Accessory Kits	Zephyr flash storage, RMM4-lite modules, TPM module, dedicated NIC module			

1.2 Intel® Server Chassis P4304XXSFCN Views

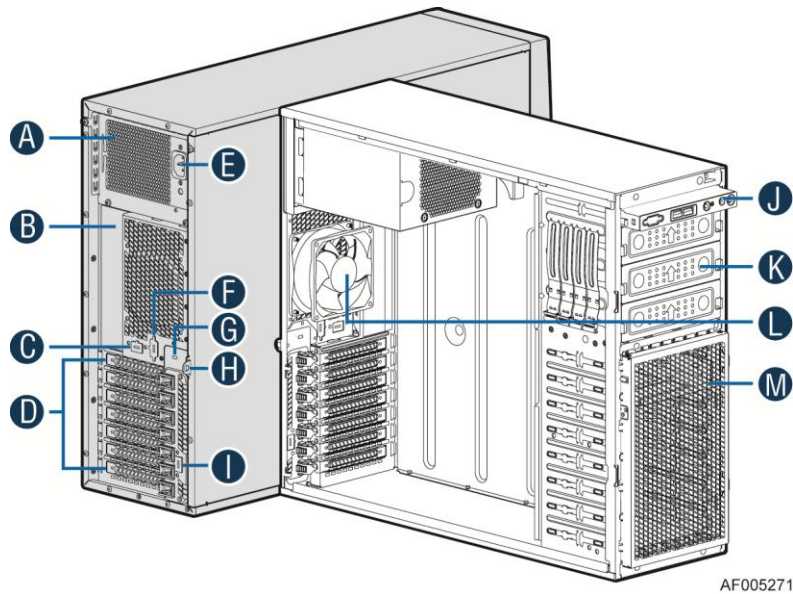

AF005271

- A. 365W Fixed Power supply
- B. I/O Ports
- C. Alternate RMM4 Knockout
- D. PCI Add-in Board Slot Covers
- E. AC Input Power Connector
- F. Serial Port Knockout
- G. A Kensington* Cable Lock Mounting Hole
- H. Padlock Loop
- I. Alternate RMM4 Knockout
- J. Front Control Panel
- K. Alternate 5.25" Peripheral Bays
- L. 92x38mm System Rear Fan
- M. Fixed Hard Drive Bays

Figure 1. Internal Chassis View of Intel® Server Chassis P4304XXSFCN

1.3 Intel® Server Chassis P4304XXSHCN Views

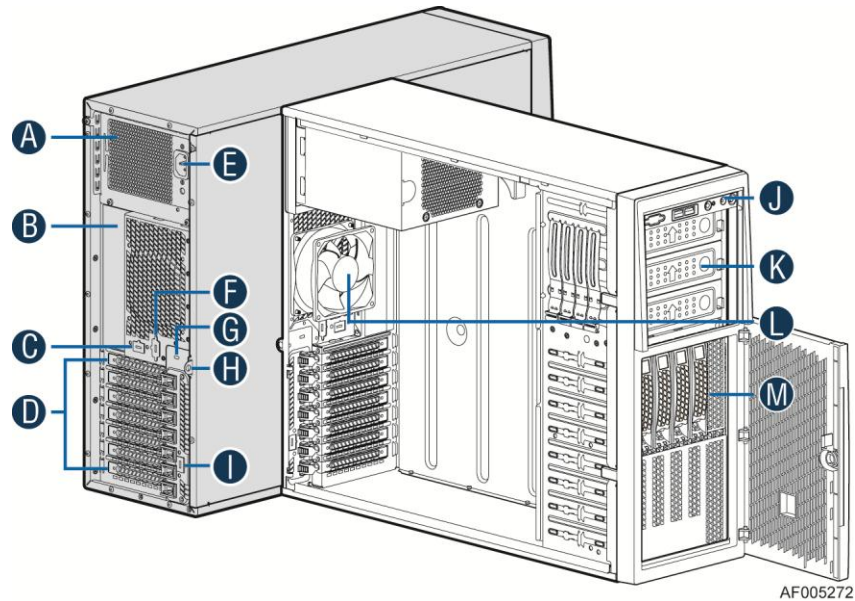

- A. 365W Fixed Power Supply
- B. I/O Ports
- C. Alternate RMM4 Knockout
- D. PCI Add-in Board Slot Covers
- E. AC Input Power Connector
- F. Serial Port Knockout
- G. A Kensington* Cable Lock Mounting Hole
- H. Padlock Loop
- I. Alternate RMM4 Knockout
- J. Front Control Panel
- K. 5.25" Peripheral Bays
- L. 92x38mm System Rear Fan
- M. 4x3.5" Hot-swap HDD Cage

Figure 2. Internal Chassis View of Intel® Server Chassis P4304XXSHCN

1.4 Intel® Server Chassis P4304XXSFEN Views

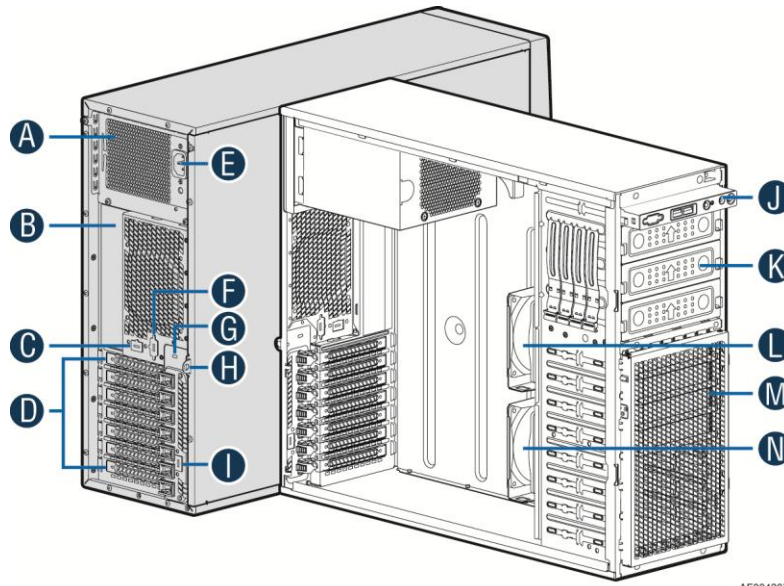

- A. 550W Fixed Power supply
- B. I/O Ports
- C. Alternate RMM4 Knockout
- D. PCI Add-in Board Slot Covers
- E. AC Input Power Connector
- F. Serial Port Knockout
- G. A Kensington* Cable Lock Mounting Hole
- H. Padlock Loop
- I. Alternate RMM4 Knockout
- J. Front Control Panel
- K. Alternate 5.25" Peripheral Bays
- L. CPU Zone System Fan
- M. Fixed Hard Drive Bays
- N. PCI Zone System Fan

Figure 3. Internal Chassis View of Intel® Server Chassis P4304XXSFEN

1.5 Intel® Server Chassis P4304XXSHEN Views

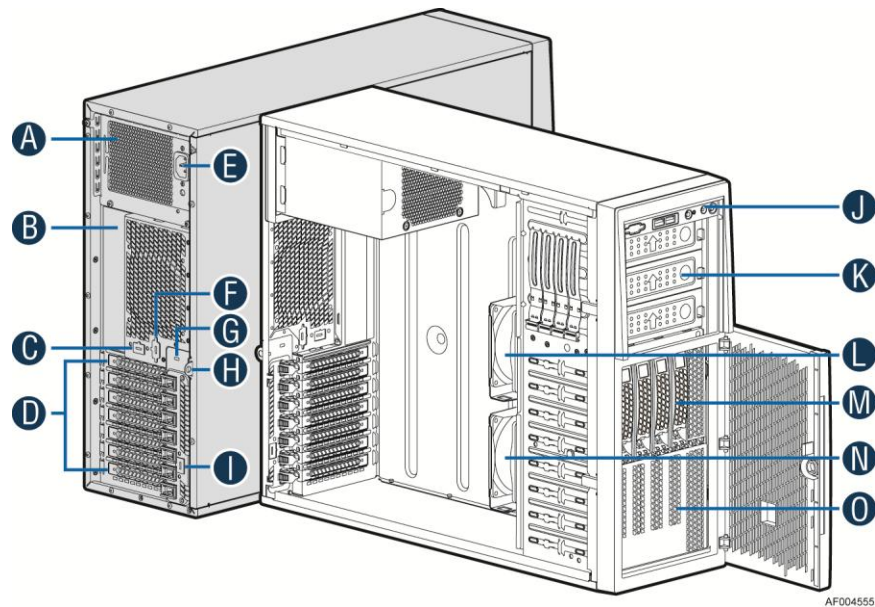

- A. 550W Fixed Power supply
- B. I/O Ports
- C. Alternate RMM4 Knockout
- D. PCI Add-in Board Slot Covers
- E. AC Input Power Connector
- F. Serial Port Knockout
- G. A Kensington* Cable Lock Mounting Hole
- H. Padlock Loop
- I. Alternate RMM4 Knockout
- J. Front Control Panel
- K. Alternate 5.25" Peripheral Bays
- L. CPU Zone System Fan
- M. 4x3.5" Hot-swap HDD Cage
- N. PCI Zone System Fan
- O. Hot-swap HDD EMI Shield

Figure 4. Internal Chassis View of Intel® Server Chassis P4304XXSHEN

1.6 Intel® Server Chassis P4304XXSFDR Views

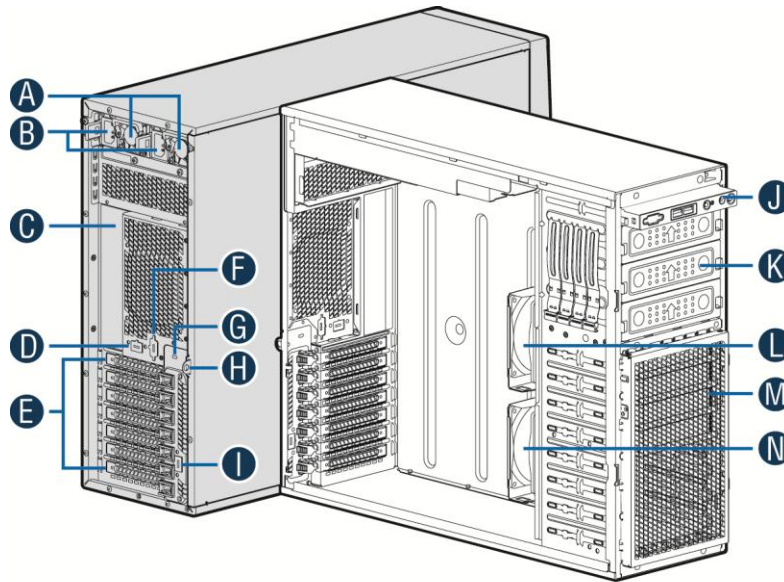

AF004556

- A. 460W Redundant Power Supply (Two)
- B. AC Input Power Connector (Two)
- C. I/O Ports
- D. Alternate RMM4 Knockout
- E. PCI Add-in Board Slot Covers
- F. Serial Port Knockout
- G. A Kensington* Cable Lock Mounting Hole
- H. Padlock Loop
- I. Alternate RMM4 Knockout
- J. Front Control Panel
- K. Alternate 5.25" Peripheral Bays
- L. CPU Zone System Fan
- M. Fixed Hard Drive Bays
- N. PCI Zone System Fan

Figure 5. Internal Chassis View of Intel® Server Chassis P4304XXSFDR

1.7 Intel® Server Chassis P4304XXSHDR Views

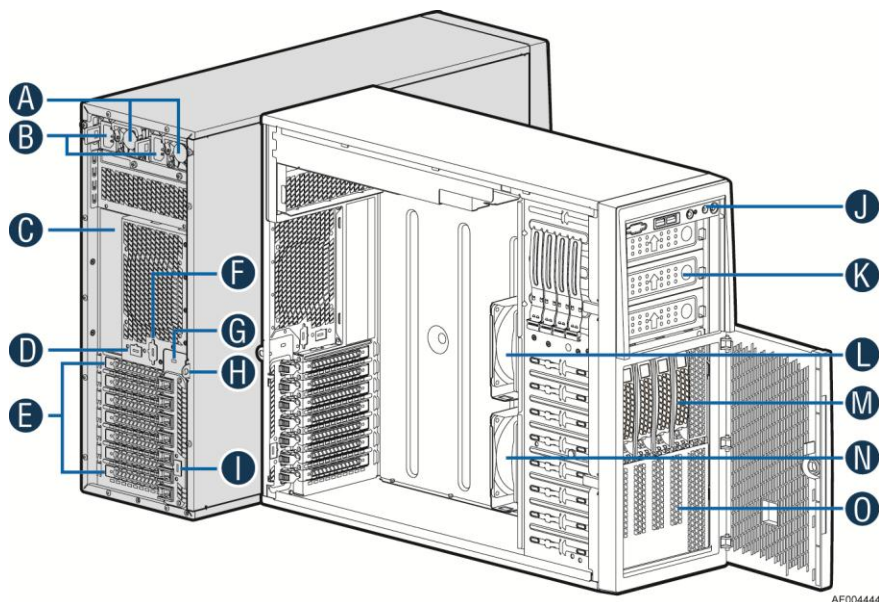

- A. 460W Redundant Power Supply (Two)
- B. AC Input Power Connector (Two)
- C. I/O Ports
- D. Alternate RMM4 Knockout
- E. PCI Add-in Board Slot Covers
- F. Serial Port Knockout
- G. A Kensington* Cable Lock Mounting Hole
- H. Padlock Loop
- I. Alternate RMM4 Knockout
- J. Front Control Panel
- K. Alternate 5.25" Peripheral Bays
- L. CPU Zone System Fan
- M. 4x3.5" Hot-swap HDD Cage
- N. PCI Zone System Fan
- O. Hot-swap HDD EMI Shield

Figure 6. Internal Chassis View of Intel® Server Chassis P4304XXSHDR

1.8 Chassis Security

A variety of chassis security options are provided at the system level:

- A removable padlock loop at the rear of the system access cover can be used to prevent access to the microprocessors, memory, and add-in cards. A variety of lock sizes can be accommodated by the 0.270-inch diameter loop.
- A Kensington* cable lock mounting hole is provided on the rear chassis I/O panel.
- A chassis intrusion switch is provided, allowing server management software to detect unauthorized access to the system side cover.

- In hot-swap hard drives configuration, a door lock is provided on the front bezel assembly with the door to prevent access to the hot-swap hard drives and the interior of the chassis.

Note: See the technical product specification appropriate to the server board for a description of BIOS and management security features for each specific supported platform. Technical product specifications can be found at <http://www.intel.com/support>.

1.9 I/O Panel

All input/output (I/O) connectors are accessible from the rear of the chassis. The SSI E-bay 3.61-compliant chassis provides an ATX 2.2-compatible cutout for I/O shield installation. Boxed Intel® server boards provide the required I/O shield for installation in the cutout. The I/O cutout dimensions are shown in the following figure for reference.

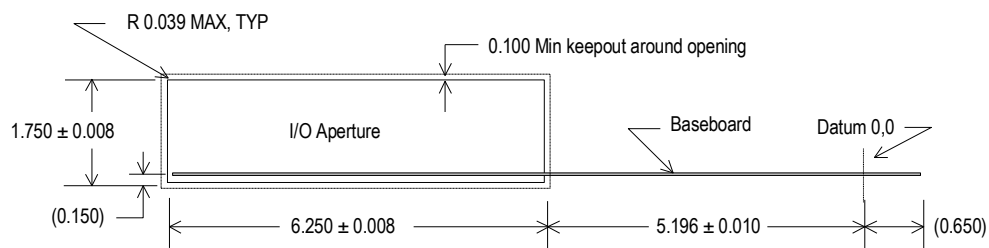

Figure 7. ATX 2.2 I/O Aperture

1.10 Front Bezel Features

There are two type of front bezel assembly in Intel® Server Chassis P4000S family.

- Front bezel assembly for fixed hard drives configuration

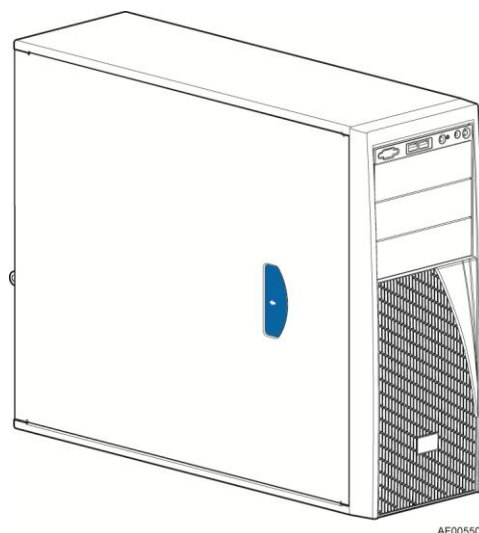
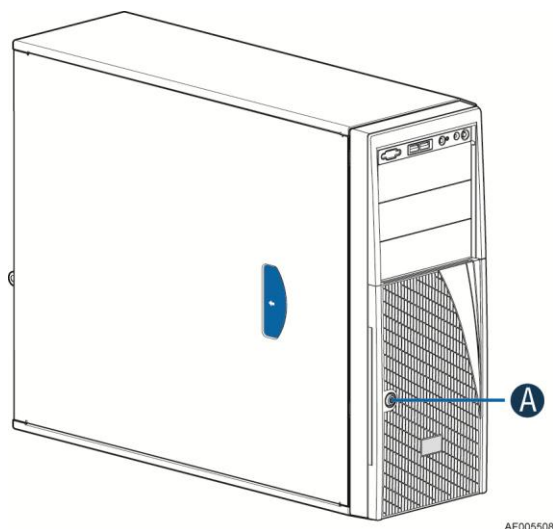

Figure 8. Front Closed Chassis View with Front Bezel for Fixed Hard Drives Configuration

- Front bezel assembly with the door for hot-swap hard drives configuration



A. Security Lock

Figure 9. Front Closed Chassis View with Front Bezel for Hot-swap Hard Drives Configuration

Both two pedestal front bezel are constructed of molded plastic and attaches to the front of the chassis with three clips on the right side and two snaps on the left. The snaps at the left attach behind the access cover, thereby preventing accidental removal of the bezel. The bezel can only be removed by first removing the server access cover. This provides additional security to the hard drive and peripheral bay area.

For the front bezel assembly for fixed hard drives configuration, removing the bezel, there is an EMI shield covering the fixed hard drives bay area.

For the front bezel assembly for hot-swap hard drives configuration, the bezel includes a key-locking door that covers the drive cage area and allows access to hot swap drives when a hot swap drive cage is installed.

The peripheral bays are covered with plastic snap-in cosmetic pieces that must be removed to add peripherals to the system. Front panel buttons and lights are located above the peripheral bays.

1.11 Front Panel Overview

The following figure shows the layout of the Front Control Panel of Intel® Server Chassis P4000S:

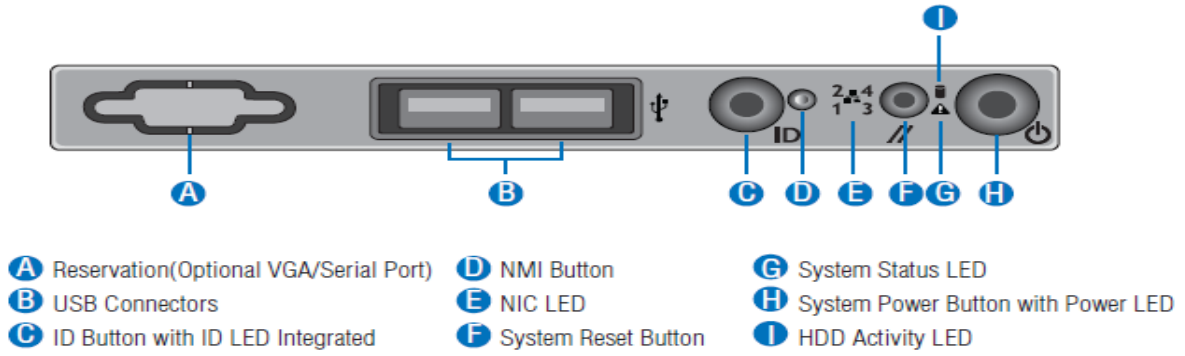
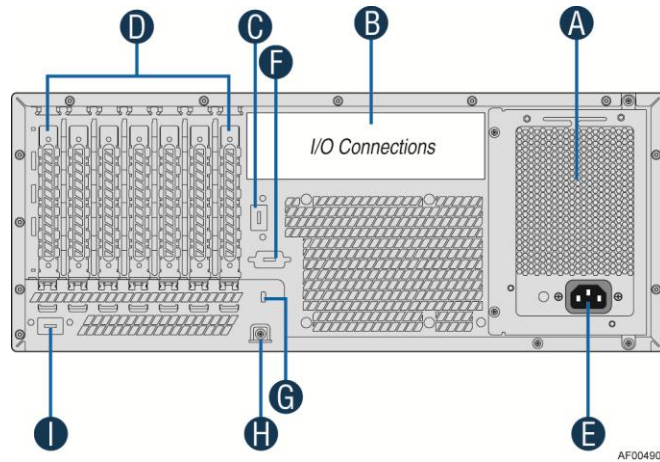

Figure 10. Front Panel Controls and Indicators

1.12 Back Panel Overview

The following figure shows the layout of Back Panel with fixed power supply and hot-swap redundant power supplies:



A	Fixed Power Supply	F	Serial-B Port (Optional)
B	IO Connectors	G	Kensington* Cable Lock Mounting Hole
C	RMM4 NIC Port (Optional)	H	Padlock Loop
D	Add in PCI-e cards	I	RMM4 NIC Port (Optional)
E	Power Connector		

Figure 11. Back Panel Layout (with Fixed Power Supply)

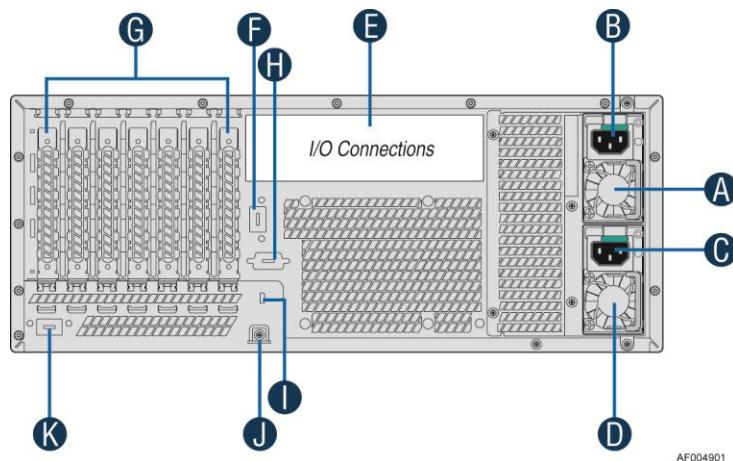

A	Hot-swap Power Supply	G	Add in PCI-e cards
B	Power Connector	H	Serial-B Port (Optional)
C	Power Connector	I	Kensington* Cable Lock Mounting Hole
D	Hot-swap Power Supply	J	Padlock Loop
E	IO Connectors	K	RMM4 NIC Port (Optional)
F	RMM4 NIC Port (Optional)		

Figure 12. Back Panel Layout (with Hot-swap Power Supply)

1.13 Standard Fixed Drive Trays

Intel® Server Chassis P4000S family supports four 3.5” fixed Hard Disk Drive trays. You can secure each of the four drives on the drive trays with screws, and install the drive trays in the chassis without a tool.

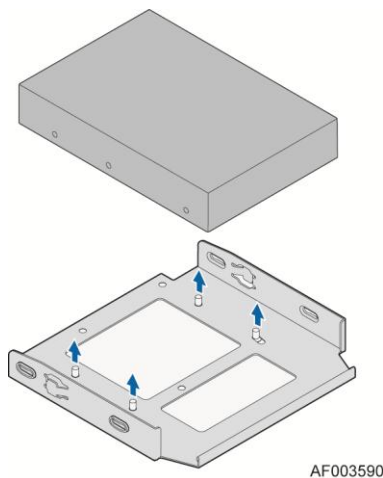
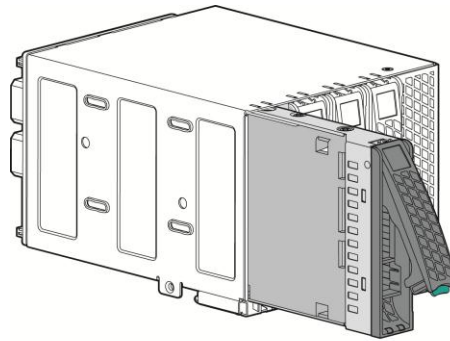

Figure 13. Fixed Drive Tray

1.14 4x3.5” Hot-Swap Hard Disk Drive Cage

The Intel® Server Chassis P4000S family supports 4x3.5” hot-swap hard drive cage, which can support up to four hot-swap hard drives.



AF003878

Figure 14. 4x3.5" Hot-Swap Hard Disk Drive Cage

1.14.1 3.5" Hot-swap Hard Drive Carrier

Each hard drive must be mounted to a hot-swap drive carrier, making insertion and extraction of the drive from the chassis very simple. Each drive carrier has its own dual-purpose latching mechanism used to both insert and extract drives from the chassis and lock the carrier in place. Each drive carrier supports a light pipe providing a drive status indicator, located on the backplane, to be viewable from the front of the chassis.

The 3.5" hot-swap hard drive carrier has a 2.5" HDD interface bracket pre-installed. The 2.5" HDD interface bracket is used for install the 2.5" hard drive on the 3.5" hot-swap hard drive carrier. When a 3.5" hard drive is to be installed, the 2.5" HDD interface bracket should be removed.

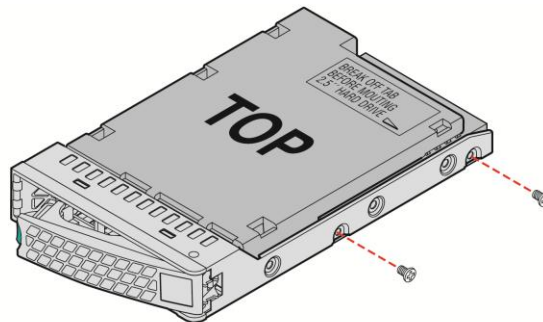

AF003879

Figure 15. 3.5" hot-swap hard drive carrier with 2.5" HDD Interface Bracket

1.15 Peripheral Bays

Three 5.25-in half-height drive bays are available for CD/DVD-ROM or tape drives as well as one 3.5-inch removable media drive bay. Drive installation is tool-less and requires no screws.

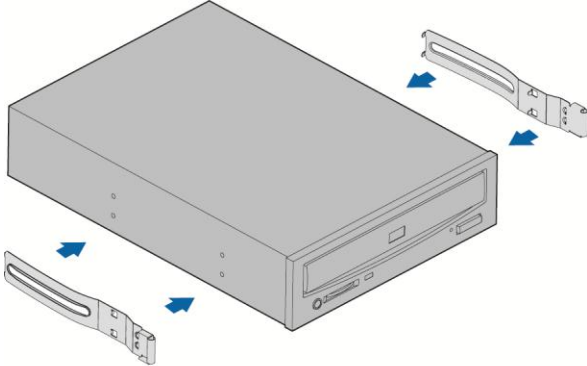

AF003538

Figure 16. Tool-less Rails Mounting 5.25-inch CD-ROM Drive

2. Chassis Power Sub-system

2.1 365W Power Supply

This 365W power supply specification defines a non-redundant power supply that supports pedestal entry server systems. The 365W power supply has 6 outputs; 3.3V, 5V, 12V1, 12V2, -12V and 5Vsb. The power supply has an AC input and be power factor corrected.

2.1.1 Mechanical Overview

The power supply size is 98mm x 150mm x 160mm (H x W x D) and has a wire harness for the DC outputs. The AC plugs directly into the external face of the power supply.

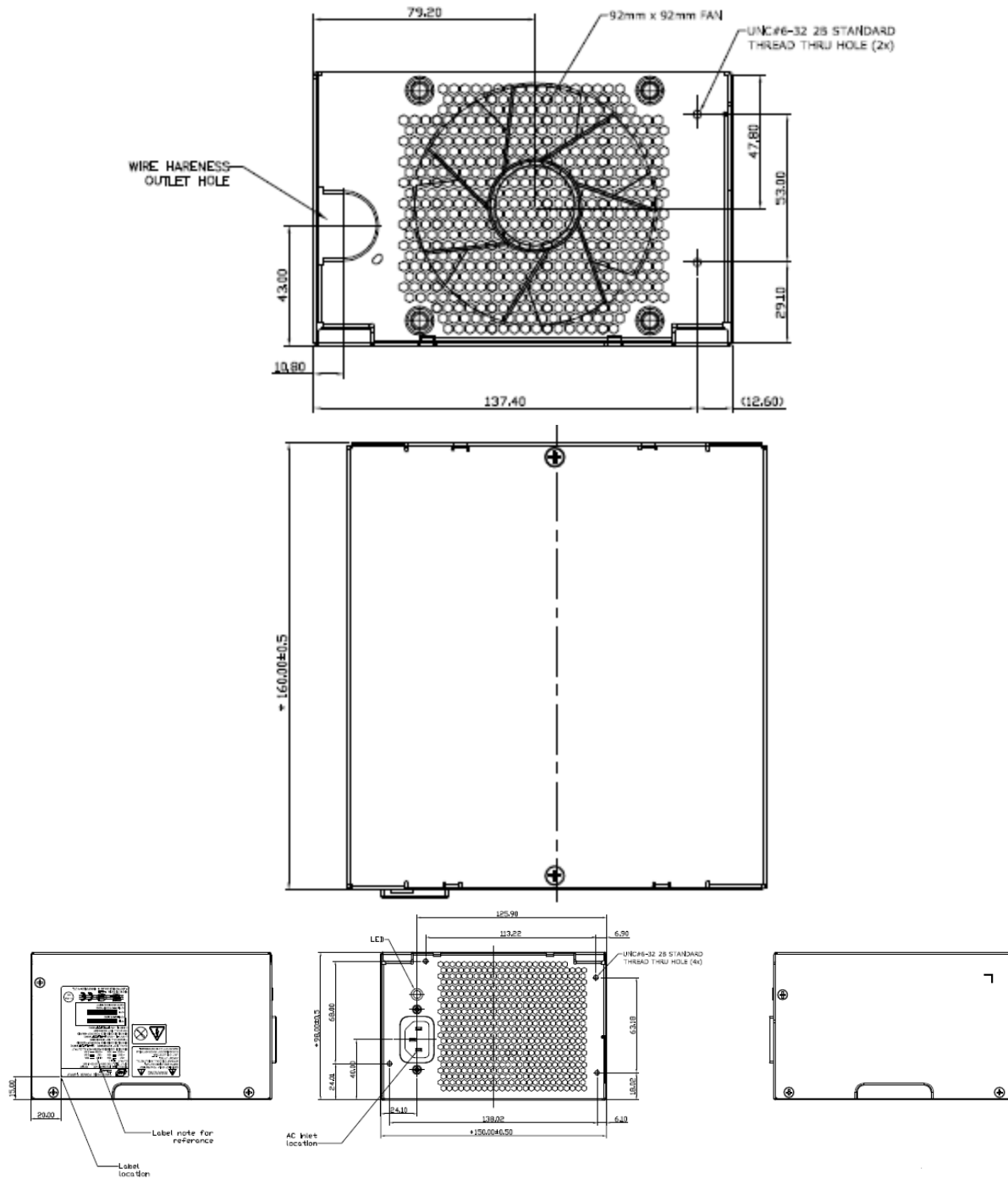

Figure 17. Mechanical Drawing for 365W Power Supply Enclosure

2.1.2 365W Power Supply Output Wire Harness

Listed or recognized component appliance wiring material (AVLV2), CN, rated min 85°C, 300VDC shall be used for all output wiring.

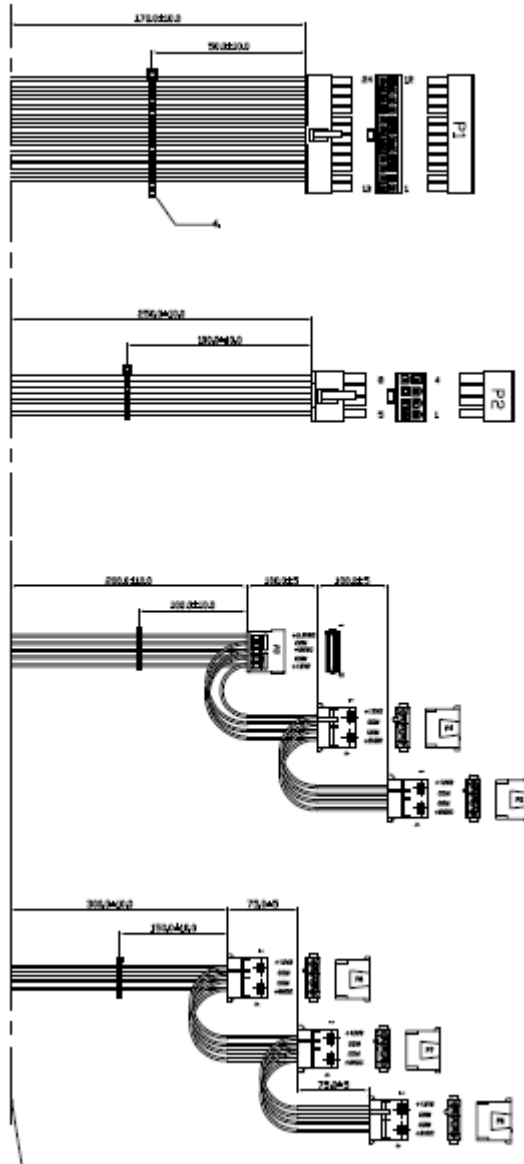

Figure 18. Output Cable Harness for 365W Power Supply

Table 2. 365W Power Supply Cable Lengths

From	Length (mm)	To connector #	No of pins	Description
Power Supply cover exit hole	290	P1	24	Baseboard Power Connector
Power Supply cover exit hole	250	P2	8	Processor Power Connector
Power Supply cover exit hole	230	P3	5	SATA Power Connector
Extension from P3	100	P4	5	SATA Power Connector
Extension from P4	100	P5	4	Peripheral Power Connector
Power Supply cover exit hole	300	P6	4	Peripheral Power Connector
Extension from P6	75	P7	4	Peripheral Power Connector
Extension from P7	75	P8	4	Peripheral Power Connector

2.1.2.1 Main power connector (P1)

Connector housing: 24- Pin Molex Mini-Fit Jr 39-01-2245 (94V2) or equivalent

Contact: Molex Minifit Jr, Crimp 5556 or equivalent

Table 3. P1 Main Power Connector

PIN	SIGNAL	18 AWG COLOR	PIN	SIGNAL	18 AWG COLOR
1	+3.3 VDC	Orange	13	+3.3 VDC	Orange
2	+3.3 VDC	Orange	14	-12 VDC	Blue
3	COM	Black	15	COM	Black
4	+5 VDC*	Red	16	PSON#	Green
5	COM	Black	17	COM	Black
6	+5 VDC	Red	18	COM	Black
7	COM	Black	19	COM	Black
8	PWR OK	Gray	20	Reserved	N.C.
9	5VSB	Purple	21	+5 VDC	Red
10	+12V2	Yellow/Black	22	+5 VDC	Red
11	+12V2	Yellow/Black	23	+5 VDC	Red
12	+3.3 VDC	Orange	24	COM	Black

2.1.2.2 Processor/Memory Power Connector (P2)

Connector housing: 8- Pin Molex 39-01-2085 (94V2) or equivalent

Contact: Molex, Mini-Fit Jr, HCS, 44476-1111 or equivalent

Table 4. P2 Processor#1 Power Connector

PIN	SIGNAL	18 AWG COLOR	PIN	SIGNAL	18 AWG COLOR
1	COM	Black	5	+12V1	Yellow
2	COM	Black	6	+12V1	Yellow
3	COM	Black	7	+12V1	Yellow

PIN	SIGNAL	18 AWG COLOR	PIN	SIGNAL	18 AWG COLOR
4	COM	Black	8	+12V1	Yellow

2.1.2.3 Peripheral Power Connectors (P4,5,6,7,8)

Connector housing: Amp 1-480424-0 or equivalent

Contact: Amp 61314-1 contact or equivalent

Table 5. Peripheral Power Connectors

Pin	Signal	18 AWG Color
1	+12V2	Yellow/Black
2	COM	Black
3	COM	Black
4	+5 VDC	Red

2.1.2.4 SATA Hard Drive Power Connectors (P3)

Connector housing: JWT A3811H00-5P (94V2) or equivalent;

Contact: JWT A3811TOP-0D or equivalent

Table 6. SATA Power Connector

Pin	Signal	18 AWG Color
1	+3.3V	Orange
2	COM	Black
3	+5VDC	Red
4	COM	Black
5	+12V2	Yellow/Black

2.1.3 Temperature Requirements

The power supply shall operate within all specified limits over the T_{op} temperature range.

Table 7. Thermal Requirements

ITEM	DESCRIPTION	MIN	MAX	UNITS
T_{op}	Operating temperature range.	0	50	°C
T_{non-op}	Non-operating temperature range.	-40	70	°C
Altitude	Maximum operating altitude.		3000	meters

2.1.4 AC Input Requirements

2.1.4.1 Power Factor

The power supply meets the power factor requirements stated in the Energy Star® Program Requirements for Computer Servers. These requirements are stated below.

Table 8. Power Factor Requirements for Computer Servers

Output power	20% load	50% load	100% load
Power factor	0.8	0.9	0.95

Tested at 230Vac, 50Hz and 60Hz and 115VAC, 60Hz.

Tested according to Generalized Internal Power Supply Efficiency Testing Protocol Rev 6.4.3.

This is posted at <http://efficientpowersupplies.epri.com/methods.asp>.

2.1.4.2 AC Inlet Connector

The AC input connector is an *IEC 320 C-14* power inlet. This inlet is rated for 10A/250VAC.

2.1.4.3 AC Input Voltage Specification

The power supply operates within all specified limits over the following input voltage range. Harmonic distortion of up to 10% of the rated line voltage does not cause the power supply to go out of specified limits. Application of an input voltage below 85VAC does not cause damage to the power supply, including a blown fuse.

Table 9. AC Input Voltage Range

PARAMETER	MIN	RATED	VMAX	Start up VAC	Power Off VAC
Voltage (110)	90 V _{rms}	100-127 V _{rms}	140 V _{rms}	85VAC +/- 4VAC	70VAC +/- 5VAC
Voltage (220)	180 V _{rms}	200-240 V _{rms}	264 V _{rms}		
Frequency	47 Hz	50/60	63 Hz		

Notes:

1. Maximum input current at low input voltage range shall be measured at 90VAC, at max load.
2. Maximum input current at high input voltage range shall be measured at 180VAC, at max load.
3. This requirement is not to be used for determining agency input current markings.

2.1.4.4 AC Line Dropout/Holdup

An AC line dropout is defined to be when the AC input drops to 0VAC at any phase of the AC line for any length of time. During an AC dropout the power supply meets dynamic voltage regulation requirements. An AC line dropout of any duration does not cause tripping of control signals or protection circuits. If the AC dropout lasts longer than the holdup time the power supply recovers and meets all turn on requirements. The power supply meets the AC dropout requirement over rated AC voltages and frequencies. A dropout of the AC line for any duration does not cause damage to the power supply.

Table 10. AC Line Holdup Time

Loading	Holdup time
75%	12msec

2.1.4.5 AC Line Fuse

The power supply has one line fused in the **single line fuse** on the line (Hot) wire of the AC input. The line fusing is acceptable for all safety agency requirements. The input fuse is a slow blow type. AC inrush current does not cause the AC line fuse to blow under any conditions. All

protection circuits in the power supply do not cause the AC fuse to blow unless a component in the power supply has failed. This includes DC output load short conditions.

2.1.4.6 AC Line Leakage Current

The maximum leakage current to ground for each power supply is 3.5mA when tested at 240VAC

2.1.4.7 AC Line Transient Specification

AC line transient conditions are defined as “sag” and “surge” conditions. “Sag” conditions are also commonly referred to as “brownout”, these conditions is defined as the AC line voltage dropping below nominal voltage conditions. “Surge” is defined to refer to conditions when the AC line voltage rises above nominal voltage.

The power supply meets the requirements under the following AC line sag and surge conditions.

Table 11. AC Line Sag Transient Performance

AC Line Sag (10sec interval between each sagging)				
Duration	Sag	Operating AC Voltage	Line Frequency	Performance Criteria
0 to 1/2 AC cycle	95%	Nominal AC Voltage ranges	50/60Hz	No loss of function or performance
> 1 AC cycle	>30 %	Nominal AC Voltage ranges	50/60Hz	Loss of function acceptable, self recoverable

Table 12. AC Line Surge Transient Performance

AC Line Surge				
Duration	Surge	Operating AC Voltage	Line Frequency	Performance Criteria
Continuous	10%	Nominal AC Voltages	50/60Hz	No loss of function or performance
0 to ½ AC cycle	30%	Mid-point of nominal AC Voltages	50/60Hz	No loss of function or performance

2.1.4.8 Power Recovery

The power supply recovers automatically after an AC power failure. AC power failure is defined to be any loss of AC power that exceeds the dropout criteria.

2.1.5 Efficiency

The following table provides the required minimum efficiency level at various loading conditions. These are provided at three different load levels; 100%, 50% and 20%. Output shall be load according to the proportional loading method defined by 80 Plus in Generalized Internal Power Supply Efficiency Testing Protocol Rev 6.4.3. This is posted at <http://efficientpowersupplies.epri.com/methods.asp>.

Table 13. Silver Efficiency Requirement

Loading	100% of maximum	50% of maximum	20% of maximum
Minimum Efficiency	85%	88%	85%

The power supply passes with enough margins to make sure in production all power supplies meet these efficiency requirements.

2.1.5.1 Standby Efficiency

When in standby mode; the power supply draws less than 1W AC power with 100mA of 5Vstandby load. This shall be tested at 115VAC/60Hz and 230VAC/50Hz

2.1.6 DC Output Specification

2.1.6.1 Output Power/Currents

The following table defines the minimum power and current ratings. The power supply meets both static and dynamic voltage regulation requirements for all conditions.

Table 14. Over Voltage Protection Limits

Parameter	Min	Max.	Peak	Unit
5V	0.3	10.0		A
12V1	0.7	16.0	18.0	A
12V2	1.5	16.0	18.0	A
3.3V	0.5	18.0		A
- 12V	0.0	0.5		A
5Vstby	0.0	2.5	3.0	A

Notes:

1. Max combined power for all output shall not exceed 365W.
2. Peak combined power for all outputs shall not exceed 385W.
3. Max combined power of 12V1 and 12V2 shall not exceed 318W.
4. Max combined power on 3.3V and 5V shall not exceed 80W.
5. Peak power and current loading shall be supported for a minimum of 12 second

2.1.6.2 Cross Loading

The power supply maintains voltage regulation limit when operated over the following cross loading conditions.

Table 15. Loading Conditions

	3.3V	5.0V	12.0V	12.0V	12.0V	5.0V	Total Power	12V Power	3.3V/5V Power
Load1	10.8	2	16	10.5	0	0.3	365	318	46
Load2	18	4.1	7.6	16	0	0.3	365	283	80
Load3	18	4.1	16	7.6	0	0.3	365	283	80
Load4	13.6	7	10.2	12	0.5	2.5	365	266	80
Load5	0.5	0.3	0.7	1.5	0	0.3	31	26	3
Load6	16	4	0.7	2.6	0	0.3	114	40	73
Load7	1.2	2.7	14.5	7.1	0	1	282	259	17

2.1.6.3 Standby Output

The 5VSB output is present when an AC input greater than the power supply turn on voltage is applied.

2.1.6.4 Voltage Regulation

The power supply output voltages stay within the following voltage limits when operating at steady state and dynamic loading conditions. These limits include the peak-peak ripple/noise. These shall be measured at the output connectors.

Table 16. Voltage Regulation Limits

PARAMETER	TOLERANCE	MIN	NOM	MAX	UNITS
+3.3V	- 5%/+5%	+3.14	+3.30	+3.46	V _{rms}
+5V	- 5%/+5%	+4.75	+5.00	+5.25	V _{rms}
+12V1	- 5%/+5%	+11.40	+12.00	+12.60	V _{rms}
+12V2	- 5%/+5%	+11.40	+12.00	+12.60	V _{rms}
- 12V	- 10%/+10%	- 13.20	-12.00	-10.80	V _{rms}
+5VSB	- 5%/+5%	+4.75	+5.00	+5.25	V _{rms}

2.1.6.5 Dynamic Loading

The output voltages remain within limits specified for the step loading and capacitive loading specified in the table below. The load transient repetition rate is tested between 50Hz and 5kHz at duty cycles ranging from 10%-90%. The load transient repetition rate is only a test specification. The Δ step load may occur anywhere within the MIN load to the MAX load conditions.

Table 17. Transient Load Requirements

Output	Δ Step Load Size (See note 2)	Load Slew Rate	Test capacitive Load
+3.3V	6.0A	0.5 A/ μ sec	970 μ F
+5V	4.0A	0.5 A/ μ sec	400 μ F
12V1+12V2	18.0A	0.5 A/ μ sec	2200 μ F ^{1,2}
+5VSB	0.5A	0.5 A/ μ sec	20 μ F

Notes:

1. Step loads on each 12V output may happen simultaneously.
2. The +12V should be tested with 2200 μ F evenly split between the four +12V rails.
3. This will be tested over the range of load conditions in section 2.1.6.2.

2.1.6.6 Capacitive Loading

The power supply is stable and meets all requirements with the following capacitive loading ranges.

Table 18. Capacitive Loading Conditions

Output	MIN	MAX	Units
+3.3V	250	5000	μ F
+5V	400	5000	μ F
+12V	500	8000	μ F

Output	MIN	MAX	Units
-12V	1	350	μF
+5VSB	20	350	μF

2.1.6.7 Grounding

The output ground of the pins of the power supply provides the output power return path. The output connector ground pins are connected to the safety ground (power supply enclosure). This grounding is well designed to ensure passing the max allowed Common Mode Noise levels.

The power supply is provided with a reliable protective earth ground. All secondary circuits are connected to protective earth ground. Resistance of the ground returns to chassis does not exceed 1.0 mΩ. This path may be used to carry DC current.

2.1.6.8 Residual Voltage Immunity in Standby mode

The power supply is immune to any residual voltage placed on its outputs (Typically a leakage voltage through the system from standby output) up to **500mV**. There is neither additional heat generated, nor stressing of any internal components with this voltage applied to any individual or all outputs simultaneously. It also does not trip the protection circuits during turn on.

The residual voltage at the power supply outputs for no load condition does not exceed **100mV** when AC voltage is applied and the PSON# signal is de-asserted.

2.1.6.9 Common Mode Noise

The Common Mode noise on any output does not exceed **350mV pk-pk** over the frequency band of 10Hz to 20MHz.

The measurement is made across a 100Ω resistor between each of DC outputs, including ground at the DC power connector and chassis ground (power subsystem enclosure).

The test set-up shall use a FET probe such as Tektronix model P6046 or equivalent.

2.1.6.10 Ripple/Noise

The maximum allowed ripple/noise output of the power supply is defined in below Table 19. This is measured over a bandwidth of 10Hz to 20MHz at the power supply output connectors. A 10μF tantalum capacitor in parallel with a 0.1μF ceramic capacitor is placed at the point of measurement.

Table 19. Ripples and Noise

+3.3V	+5V	+12V 1	+12V 2	-12V	+5VSB
50mVp-p	50mVp-p	120mVp-p	120mVp-p	200mVp-p	50mVp-p

The test set-up shall be as shown below.

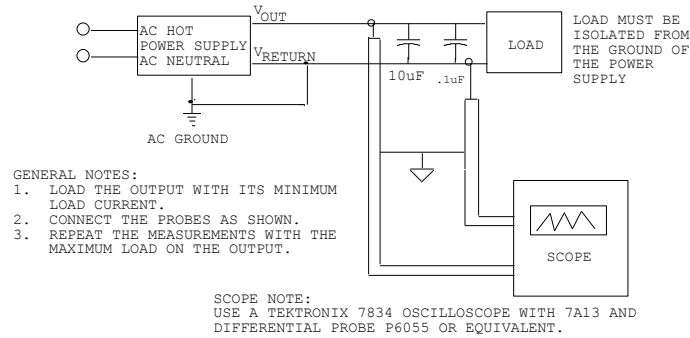

Figure 19. Differential Noise test setup

Note: When performing this test, the probe clips and capacitors should be located close to the load.

2.1.6.11 Timing Requirements

These are the timing requirements for the power supply operation. The output voltages rise from 10% to within regulation limits (T_{vout_rise}) within 2 to 50ms, except for 5VSB - it is allowed to rise from 1 to 25ms. The +3.3V, +5V and +12V1, +12V2 output voltages should start to rise approximately at the same time. **All outputs must rise monotonically.** Each output voltage reach regulation within 50ms (T_{vout_on}) of each other during turn on the power supply. Each output voltage fall out of regulation within 400ms (T_{vout_off}) of each other during turn off. Table 21 shows the timing requirements for the power supply being turned on and off from the AC input, with PSON held low and the PSON signal, with the AC input applied.

Table 20. Output Voltage Timing

Item	Description	MIN	MAX	UNITS
T_{vout_rise}	Output voltage rise time from each main output.	2	50	ms
	Output rise time for the 5Vstby output.	1	25	ms
T_{vout_on}	All main outputs must be within regulation of each other within this time.		50	ms
T_{vout_off}	All main outputs must leave regulation within this time.		400	ms

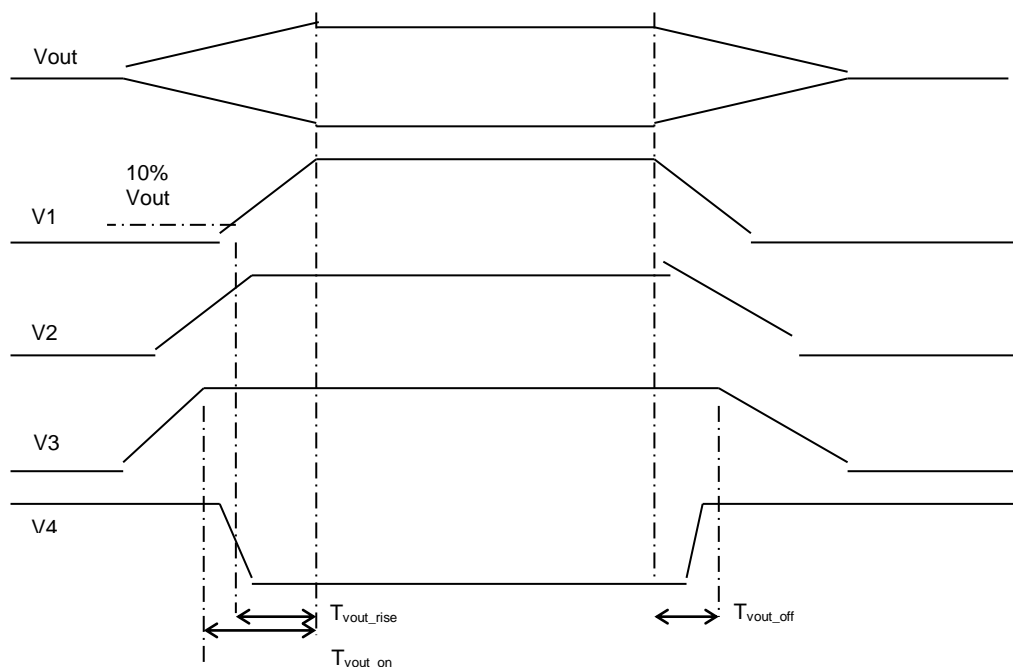

Figure 20. Output Voltage Timing

Table 21. Turn On/Off Timing

Item	Description	Min.	Max.	Units
T _{sb_on_delay}	Delay from AC being applied to 5VSB being within regulation.		1500	ms
T _{ac_on_delay}	Delay from AC being applied to all output voltages being within regulation.		2500	ms
T _{vout_holdup}	Time all output voltages stay within regulation after loss of AC. Tested at 75% of maximum load.	13		ms
T _{pwok_holdup}	Delay from loss of AC to de-assertion of PWOK. Tested at 75% of maximum load.	12		ms
T _{pson_on_delay}	Delay from PSON [#] active to output voltages within regulation limits.	5	400	ms
T _{pson_pwok}	Delay from PSON [#] deactivate to PWOK being de-asserted.		50	ms
T _{pwok_on}	Delay from output voltages within regulation limits to PWOK asserted at turn on.	100	500	ms
T _{pwok_off}	Delay from PWOK de-asserted to output voltages (3.3V, 5V, 12V, -12V) dropping out of regulation limits.	1		ms
T _{pwok_low}	Duration of PWOK being in the de-asserted state during an off/on cycle using AC or the PSON signal.	100		ms
T _{sb_vout}	Delay from 5VSB being in regulation to O/Ps being in regulation at AC turn on.	10	1000	ms
T _{5VSB_holdup}	Time the 5VSB output voltage stays within regulation after loss of AC.	70		ms

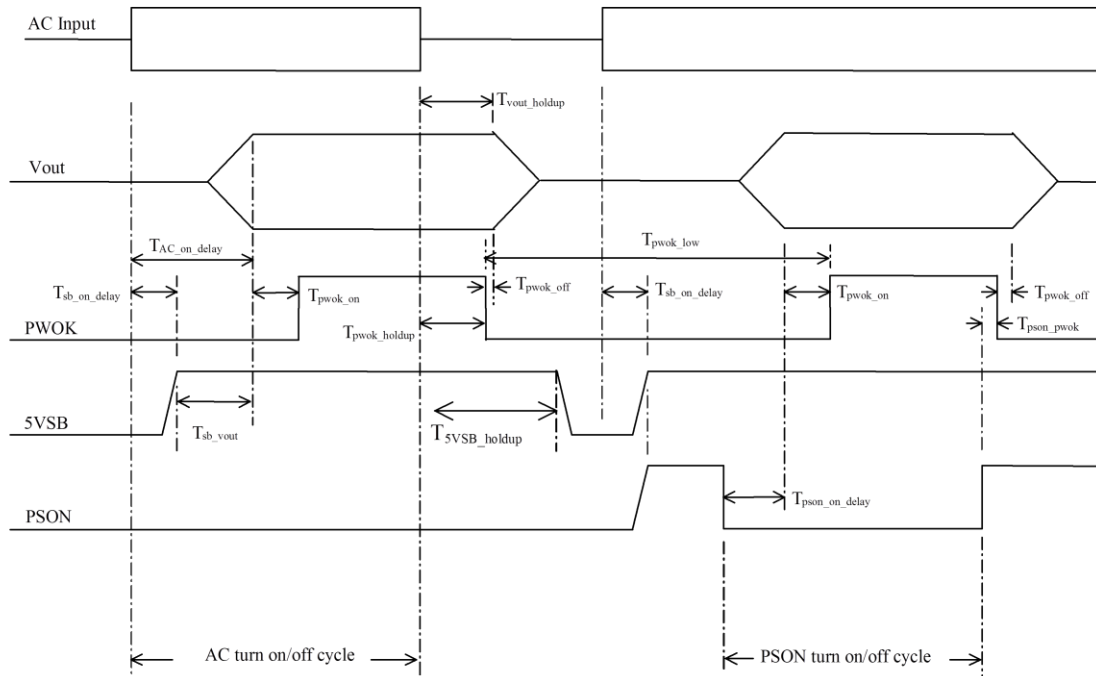

Figure 21. Turn On/Off Timing (Power Supply Signals)

2.1.7 Protection Circuits

Protection circuits inside the power supply causes only the power supply's main outputs to shutdown. If the power supply latches off due to a protection circuit tripping, an AC cycle OFF for 15sec and a PSON# cycle HIGH for 1sec able to reset the power supply.

2.1.7.1 Current Limit (OCP)

Overload currents applied to each tested output rail will cause the output to trip before they reach or exceed 240 VA. If the current limits are exceeded the power supply shuts down and latches off. The latch will be cleared by toggling the PSON# signal or by an AC power interruption. The power supply does not be damaged from repeated power cycling in this condition. -12V and 5VSB is protected under over current or shorted conditions so that no damage can occur to the power supply. 5Vsb will be auto-recovered after removing OCP limit.

2.1.7.2 Over Voltage Protection (OVP)

The power supply over voltage protection is locally sensed. The power supply shuts down and latches off after an over voltage condition occurs. This latch is cleared by toggling the PSON# signal or by an AC power interruption. Below Table 22 contains the over voltage limits. The values are measured at the output of the power supply's pins. The voltage shall never exceed the maximum levels when measured at the power pins of the power supply connector during any single point of fail. The voltage shall never trip any lower than the minimum levels when measured at the power pins of the power supply connector. 5Vsb will be auto-recovered after removing OVP limit.

Table 22. Over Voltage Protection (OVP) Limits

Output Voltage	MAX (V)
+3.3V	4.5
+5V	6.5
+12V1,2	14.5
+5VSB	6.5

2.1.7.3 Over Temperature Protection (OTP)

The power supply will be protected against over temperature conditions caused by loss of fan cooling or excessive ambient temperature. In an OTP condition the PSU will shutdown.

2.1.8 Control and Indicator Functions

The following sections define the input and output signals from the power supply. Signals that can be defined as low true use the following convention: Signal# = low true

2.1.8.1 PSON# Input Signal

The PSON# signal is required to remotely turn on/off the power supply. PSON# is an active low signal that turns on the +3.3V, +5V, +12V1, +12V2 and -12V power rails. When this signal is not pulled low by the system, or left open, the outputs (except the +5VSB) turn off. This signal is pulled to a standby voltage by a pull-up resistor internal to the power supply. Refer

Figure 21 for the timing diagram.

Table 23. PSON# Signal Characteristic

Signal Type	Accepts an open collector/drain input from the system. Pull-up to VSB located in power supply.	
PSON# = Low	ON	
PSON# = High or Open	OFF	
	MIN	MAX
Logic level low (power supply ON)	0V	1.0V
Logic level high (power supply OFF)	2.0V	5.25V
Source current, Vpson = low		4mA
Power up delay: T _{pson_on_delay}	5msec	400msec
PWOK delay: T _{pson_pwok}		50msec

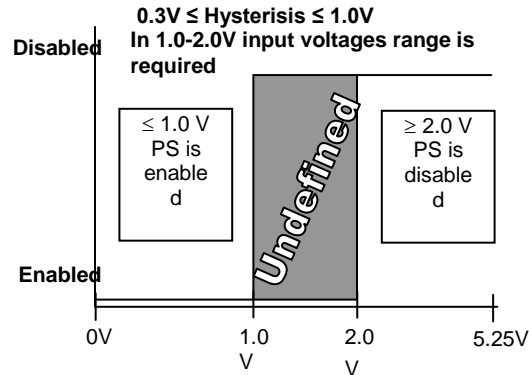

Figure 22. PSON# Required Signal Characteristic

2.1.8.2 PWOK (Power OK) Output Signal

PWOK is a power OK signal and will be pulled HIGH by the power supply to indicate that all the outputs are within the regulation limits of the power supply. When any output voltage falls below regulation limits or when AC power has been removed for a time sufficiently long so that power supply operation is no longer guaranteed, PWOK will be de-asserted to a LOW state. See below table for a representation of the timing characteristics of PWOK. The start of the PWOK delay time shall be inhibited as long as any power supply output is in current limit.

Table 24. PWOK Signal Characteristics

Signal Type	Open collector/drain output from power supply. Pull-up to VSB located in system.	
PWOK = High	Power OK	
PWOK = Low	Power Not OK	
	MIN	MAX
Logic level low voltage, $I_{sink}=4mA$	0V	0.4V
Logic level high voltage, $I_{source}=200\mu A$	2.4V	5.25V
Sink current, PWOK = low		4mA
Source current, PWOK = high		2mA
PWOK delay: T_{pwok_on}	100ms	500ms
PWOK rise and fall time		100 μ sec
Power down delay: T_{pwok_off}	1ms	

2.2 550W Power Supply

This 550W power supply specification defines a non-redundant power supply that supports pedestal entry server systems. The 550W power supply has 7 outputs; 3.3V, 5V, 12V1, 12V2, 12V3, -12V and 5Vsb, with no less than 550W. The power supply has an AC input and be power factor corrected.

2.2.1 Mechanical Overview

The power supply size is 98mm x 150mm x 160mm (H x W x D) and has a wire harness for the DC outputs. The AC plugs directly into the external face of the power supply.

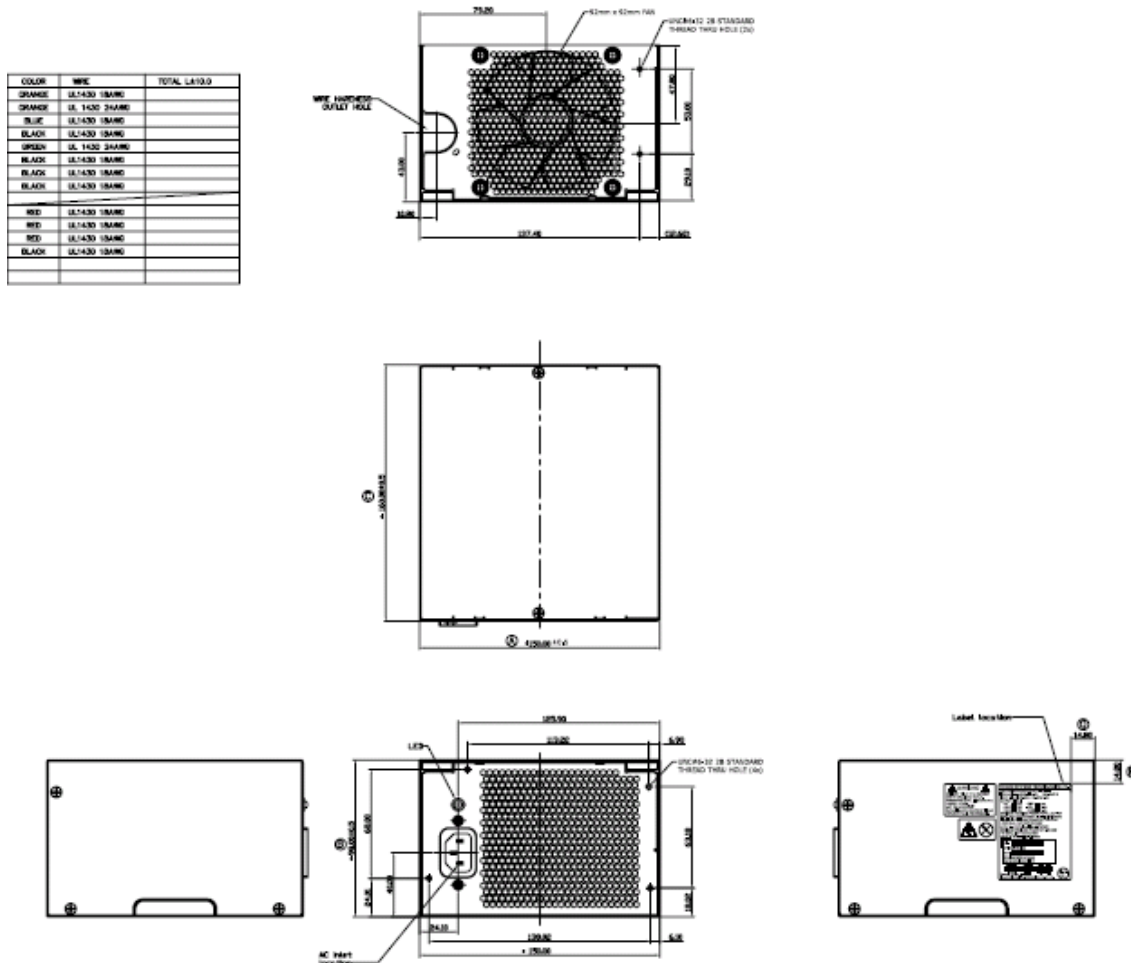

Figure 23. Mechanical Drawing for 550W Power Supply Enclosure

2.2.1.1 550W Power Supply Output Wire Harness

Listed or recognized component appliance wiring material (AVLV2), CN, rated min 85°C shall be used for all output wiring.

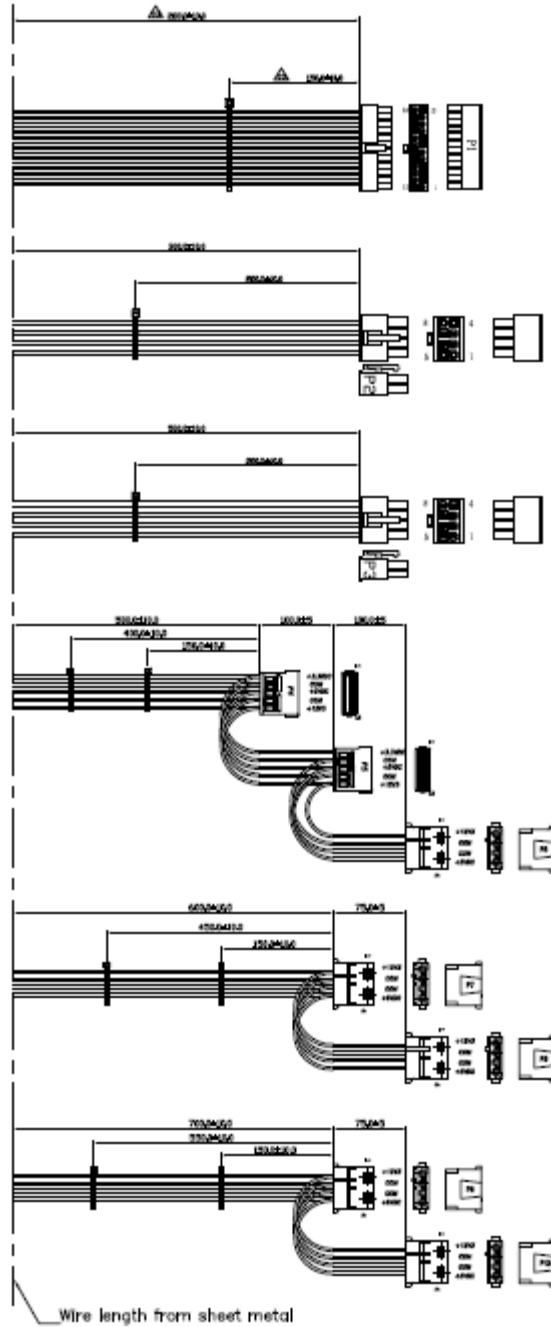

Figure 24. Output Cable Harness for 550W Power Supply

Table 25. Power Supply Cable Lengths

From	Length (mm)	To connector #	No of pins	Description
Power Supply cover exit hole	280	P1	24	Baseboard Power Connector
Power Supply cover exit hole	300	P2	8	Processor 0 connector
Power Supply cover exit hole	500	P3	8	Processor 1 connector
Power Supply cover exit hole	500	P4	5	SATA Peripheral Power

From	Length (mm)	To connector #	No of pins	Description
				Connector for 5.25"
Extension from P4	100	P5	5	SATA Peripheral Power Connector for 5.25"
Extension from P5	100	P6	4	Peripheral Power Connector for 5.25"
Power Supply cover exit hole	600	P7	4	1x4 Legacy HSBP Power Connector
Extension from P7	75	P8	4	1x4 Legacy HSBP Power Connector
Power Supply cover exit hole	700	P9	4	1x4 Legacy HSBP Power/Fixed HDD Adapter Connection
Extension from P9	75	P10	4	1x4 Legacy HSBP Power/Fixed HDD Adapter Connection

2.2.1.1.1 Main power connector (P1)

Connector housing: 24- Pin Molex Mini-Fit Jr 39-01-2245 (94V2) or equivalent

Contact: Molex Minifit Jr, Crimp 5556 or equivalent

Table 26. P1 Main Power Connector

Pin	Signal	18 awg color	Pin	Signal	18 awg color
1	+3.3 VDC	Orange	13	+3.3 VDC	Orange
2	+3.3 VDC	Orange	14	-12 VDC	Blue
3	COM	Black	15	COM	Black
4	+5 VDC*	Red	16	PSON#	Green
5	COM	Black	17	COM	Black
6	+5 VDC	Red	18	COM	Black
7	COM	Black	19	COM	Black
8	PWR OK	Gray	20	Reserved	N.C.
9	5VSB	Purple	21	+5 VDC	Red
10	+12V3	Yellow/Black	22	+5 VDC	Red
11	+12V3	Yellow/Black	23	+5 VDC	Red
12	+3.3 VDC	Orange	24	COM	Black

Note: 3.3V remote sense shall be double crimped into pin 13 if needed to meet regulation limits.

2.2.1.1.2 Processor/Memory Power Connector (P2)

Connector housing: 8- Pin Molex 39-01-2085 (94V2) or equivalent

Contact: Molex, Mini-Fit Jr, HCS, 44476-1111 or equivalent

Table 27. P2 Processor#1 Power Connector

Pin	Signal	18 awg color	Pin	Signal	18 awg color
1	COM	Black	5	+12V1	Yellow

Pin	Signal	18 awg color	Pin	Signal	18 awg color
2	COM	Black	6	+12V1	Yellow
3	COM	Black	7	+12V1	Yellow
4	COM	Black	8	+12V1	Yellow

2.2.1.1.3 Processor/Memory Power Connector (P3)

Connector housing: 8- Pin Molex 39-01-2085 (94V2) or equivalent
 Contact: Molex, Mini-Fit Jr, HCS, 44476-1111 or equivalent

Table 28. P3 Processor#1 Power Connector

Pin	Signal	18 awg color	Pin	Signal	18 awg color
1	COM	Black	5	+12V2	Yellow
2	COM	Black	6	+12V2	Yellow
3	COM	Black	7	+12V2	Yellow
4	COM	Black	8	+12V2	Yellow

2.2.1.1.4 Peripheral Power Connectors (P6,7,8,9,10)

Connector housing: Amp 1-480424-0 or equivalent
 Contact: Amp 61314-1 contact or equivalent

Table 29. Peripheral Power Connectors

Pin	Signal	18 AWG Color
1	+12V3	Yellow/Black
2	COM	Black
3	COM	Black
4	+5 VDC	Red

2.2.1.1.5 SATA Hard Drive Power Connectors (P4, P5)

Connector housing: JWT A3811H00-5P (94V2) or equivalent;
 Contact: JWT A3811TOP-0D or equivalent

Table 30. SATA Power Connector

Pin	Signal	18 AWG Color
1	+3.3V	Orange
2	COM	Black
3	+5VDC	Red
4	COM	Black
5	+12V3	Yellow/Black

2.2.2 Temperature Requirements

The power supply shall operate within all specified limits over the T_{op} temperature range.

Table 31. Thermal Requirements

Item	Description	Min	Max	Units
T _{op}	Operating temperature range.	0	50	°C
T _{non-op}	Non-operating temperature range.	-40	70	°C
Altitude	Maximum operating altitude.		3000	meters

2.2.3 AC Input Requirements

2.2.3.1 Power Factor

The power supply meets the power factor requirements stated in the Energy Star® Program Requirements for Computer Servers. These requirements are stated below.

Table 32. Power Factor Requirements for Computer Servers

Output power	20% load	50% load	100% load
Power factor	0.8	0.9	0.95

Tested at 230Vac, 50Hz and 60Hz and 115VAC, 60Hz.

Tested according to Generalized Internal Power Supply Efficiency Testing Protocol Rev 6.4.3.

This is posted at <http://efficientpowersupplies.epri.com/methods.asp>.

2.2.3.2 AC Inlet Connector

The AC input connector is an IEC 320 C-14 power inlet. This inlet is rated for 10A/250VAC.

2.2.3.3 AC Input Voltage Specification

The power supply operates within all specified limits over the following input voltage range. Harmonic distortion of up to 10% of the rated line voltage does not cause the power supply to go out of specified limits. Application of an input voltage below 85VAC does not cause damage to the power supply, including a blown fuse.

Table 33. AC Input Voltage Range

Parameter	Min	Rated	V _{max}	Start up vac	Power off vac
Voltage (110)	90 V _{rms}	100-127 V _{rms}	140 V _{rms}	85VAC +/- 4VAC	70VAC +/- 5VAC
Voltage (220)	180 V _{rms}	200-240 V _{rms}	264 V _{rms}		
Frequency	47 Hz	50/60	63 Hz		

Notes:

- 1 Maximum input current at low input voltage range shall be measured at 90VAC, at max load.
- 2 Maximum input current at high input voltage range shall be measured at 180VAC, at max load.
- 3 This requirement is not to be used for determining agency input current markings.

2.2.3.4 AC Line Dropout/Holdup

An AC line dropout is defined to be when the AC input drops to 0VAC at any phase of the AC line for any length of time. During an AC dropout the power supply meets dynamic voltage

regulation requirements. An AC line dropout of any duration does not cause tripping of control signals or protection circuits. If the AC dropout lasts longer than the holdup time the power supply recovers and meets all turn on requirements. The power supply meets the AC dropout requirement over rated AC voltages and frequencies. A dropout of the AC line for any duration does not cause damage to the power supply.

Table 34. AC Line Holdup time

Loading	Holdup time
75%	12msec

2.2.3.5 AC Line Fuse

The power supply has one line fused in the **single line fuse** on the line (Hot) wire of the AC input. The line fusing is acceptable for all safety agency requirements. The input fuse is a slow blow type. AC inrush current does not cause the AC line fuse to blow under any conditions. All protection circuits in the power supply do not cause the AC fuse to blow unless a component in the power supply has failed. This includes DC output load short conditions

2.2.3.6 AC Line Leakage Current

The maximum leakage current to ground for each power supply is 3.5mA when tested at 240VAC.

2.2.3.7 AC Line Transient Specification

AC line transient conditions are defined as “sag” and “surge” conditions. “Sag” conditions are also commonly referred to as “brownout”, these conditions is defined as the AC line voltage dropping below nominal voltage conditions. “Surge” is defined to refer to conditions when the AC line voltage rises above nominal voltage.

The power supply meets the requirements under the following AC line sag and surge conditions.

Table 35. AC Line Sag Transient Performance

AC Line Sag (10sec interval between each sagging)				
Duration	Sag	Operating AC Voltage	Line Frequency	Performance Criteria
0 to 1/2 AC cycle	95%	Nominal AC Voltage ranges	50/60Hz	No loss of function or performance
> 1 AC cycle	>30 %	Nominal AC Voltage ranges	50/60Hz	Loss of function acceptable, self recoverable

Table 36. AC Line Surge Transient Performance

AC Line Surge				
Duration	Surge	Operating AC Voltage	Line Frequency	Performance Criteria
Continuous	10%	Nominal AC Voltages	50/60Hz	No loss of function or performance
0 to ½ AC cycle	30%	Mid-point of nominal AC Voltages	50/60Hz	No loss of function or performance

2.2.3.8 Power Recovery

The power supply recovers automatically after an AC power failure. AC power failure is defined to be any loss of AC power that exceeds the dropout criteria.

2.2.4 Efficiency

The following table provides the required minimum efficiency level at various loading conditions. These are provided at three different load levels; 100%, 50% and 20%. Output shall be load according to the proportional loading method defined by 80 Plus in Generalized Internal Power Supply Efficiency Testing Protocol Rev 6.4.3. This is posted at <http://efficientpowersupplies.epri.com/methods.asp>.

Table 37. Silver Efficiency Requirement

Loading	100% of maximum	50% of maximum	20% of maximum
Minimum Efficiency	85%	88%	85%

The power supply passes with enough margins to make sure in production all power supplies meet these efficiency requirements.

2.2.4.1 Standby Efficiency

When in standby mode; the power supply draws less than 1W AC power with 100mA of 5Vstandby load. This is tested at 115VAC/60Hz and 230VAC/50Hz.

2.2.5 DC Output Specification

2.2.5.1 Output Power/Currents

The following tables define the minimum power and current ratings. The power supply meets both static and dynamic voltage regulation requirements for all conditions.

Table 38. Over Voltage Protection Limits

Parameter	Min	Max.	Peak	Unit
3.3V	0.5	18.0		A
5V	0.3	15.0		A
12V1	0.7	24.0	28.0	A
12V2	0.7	24.0	28.0	A
12V3	1.5	18.0		
- 12V	0.0	0.5		A
5Vstby	0.0	3.0	3.5	A

Notes:

1. Max combined power for all output shall not exceed 550W.
2. Peak combined power for all outputs shall not exceed 630W for 20 seconds.
3. Max combined power of 12V1, 12V2 and 12V3 shall not exceed 530W.
4. Max combined power on 3.3V and 5V shall not exceed 120W.

2.2.5.2 Cross Loading

The power supply maintains voltage regulation limit when operated over the following cross loading conditions.

Table 39. Loading Conditions

	3.3V	5.0V	12V1	12V2	12V3	-12V	5.0Vstby	Total Power	12V Power	3.3V/5V Power
Load1	18	12.1	12	12	11.7	0	0.3	550	428	120
Load2	13.5	15	12	12	11.2	0.5	0.3	549	422	120
Load3	2.5	2	20	20	4.2	0	0.3	550	530	18
Load4	2.5	2	13.1	13.1	18	0	0.3	550	530	18
Load5	0.5	0.3	15	15	6.5	0.5	3	462	438	3
Load6	16	4	1	1	3.5	0	0.3	140	66	73
Load7	16	13	1	1	9	0.5	3	271	132	118

2.2.5.3 Standby Output

The 5VSB output is present when an AC input greater than the power supply turn on voltage is applied.

2.2.5.4 Voltage Regulation

The power supply output voltages stay within the following voltage limits when operating at steady state and dynamic loading conditions. These limits include the peak-peak ripple/noise. These shall be measured at the output connectors.

Table 40. Voltage Regulation Limits

Parameter	Tolerance	Min	Nom	Max	Units
+3.3V	- 3%/+5%	+3.20	+3.30	+3.46	Vrms
+5V	- 4%/+5%	+4.80	+5.00	+5.25	Vrms
+12V1	- 4%/+5%	+11.52	+12.00	+12.60	Vrms
+12V2	- 4%/+5%	+11.52	+12.00	+12.60	Vrms
+12V3	- 4%/+5%	+11.52	+12.00	+12.60	Vrms
- 12V	- 10%/+10%	- 13.20	-12.00	-10.80	Vrms
+5VSB	- 4%/+5%	+4.80	+5.00	+5.25	Vrms

2.2.5.5 Dynamic Loading

The output voltages remain within limits specified for the step loading and capacitive loading specified in the table below. The load transient repetition rate is tested between 50Hz and 5kHz at duty cycles ranging from 10%-90%. The load transient repetition rate is only a test specification. The Δ step load may occur anywhere within the MIN load to the MAX load conditions.

Table 41. Transient Load Requirements

Output	Δ Step Load Size (See note 2)	Load Slew Rate	Test capacitive Load
+3.3V	6.0A	0.5 A/ μ sec	970 μ F
+5V	4.0A	0.5 A/ μ sec	400 μ F
12V1+12V2+12V3	23.0A	0.5 A/ μ sec	2200 μ F ^{1,2}
+5VSB	0.5A	0.5 A/ μ sec	20 μ F

Notes:

1. Step loads on each 12V output may happen simultaneously.
2. The +12V should be tested with 2200 μ F evenly split between the four +12V rails
3. This will be tested over the range of load conditions in section 2.1.6.2.

2.2.5.6 Capacitive Loading

The power supply is stable and meets all requirements with the following capacitive loading ranges.

Table 42. Capacitive Loading Conditions

Output	Min	Max	Units
+3.3V	250	5000	μ F
+5V	400	5000	μ F
+12V	500	8000	μ F
-12V	1	350	μ F
+5VSB	20	350	μ F

2.2.5.7 Grounding

The output ground of the pins of the power supply provides the output power return path. The output connector ground pins are connected to the safety ground (power supply enclosure). This grounding is well designed to ensure passing the max allowed Common Mode Noise levels.

The power supply is provided with a reliable protective earth ground. All secondary circuits are connected to protective earth ground. Resistance of the ground returns to chassis does not exceed 1.0 m Ω . This path may be used to carry DC current.

2.2.5.8 Residual Voltage Immunity in Standby mode

The power supply is immune to any residual voltage placed on its outputs (Typically a leakage voltage through the system from standby output) up to **500mV**. There is neither additional heat generated, nor stressing of any internal components with this voltage applied to any individual or all outputs simultaneously. It also does not trip the protection circuits during turn on.

The residual voltage at the power supply outputs for no load condition does not exceed **100mV** when AC voltage is applied and the PSON# signal is de-asserted.

2.2.5.9 Common Mode Noise

The Common Mode noise on any output does not exceed **350mV pk-pk** over the frequency band of 10Hz to 20MHz.

The measurement is made across a 100 Ω resistor between each of DC outputs, including ground at the DC power connector and chassis ground (power subsystem enclosure). The test set-up shall use a FET probe such as Tektronix model P6046 or equivalent.

2.2.5.10 Ripple/Noise

The maximum allowed ripple/noise output of the power supply is defined in the table below. This is measured over a bandwidth of 10Hz to 20MHz at the power supply output connectors. A 10 μ F tantalum capacitor in parallel with a 0.1 μ F ceramic capacitor is placed at the point of measurement.

Table 43. Ripples and Noise

+3.3V	+5V	+12V 1,2,3	-12V	+5VSB
50mVp-p	50mVp-p	120mVp-p	200mVp-p	50mVp-p

The test set-up shall be as shown below.

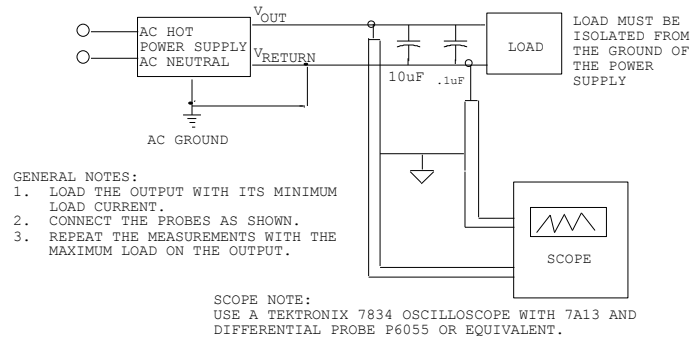

Figure 25. Differential Noise test setup

Note: When performing this test, the probe clips and capacitors should be located close to the load.

2.2.5.11 Timing Requirements

These are the timing requirements for the power supply operation. The output voltages rise from 10% to within regulation limits (T_{vout_rise}) within 2 to 50ms, except for 5VSB - it is allowed to rise from 1 to 25ms. The +3.3V, +5V and +12V1, +12V2, +12V3 output voltages start to rise approximately at the same time. **All outputs rise monotonically.** Each output voltage reach regulation within 50ms (T_{vout_on}) of each other during turn on the power supply. Each output voltage fall out of regulation within 400ms (T_{vout_off}) of each other during turn off. Table 45 shows the timing requirements for the power supply being turned on and off by the AC input, with PSON held low and the PSON signal, with the AC input applied. All timing requirements are met for the cross loading condition in Table 39.

Table 44. Output Voltage Timing

Item	Description	MIN	MAX	UNITS
T_{vout_rise}	Output voltage rise time from each main output.	2	50	ms
	Output rise time for the 5Vstby output.	1	25	ms
T_{vout_on}	All main outputs must be within regulation of each other within this time.		50	ms
T_{vout_off}	All main outputs must leave regulation within this time.		400	ms

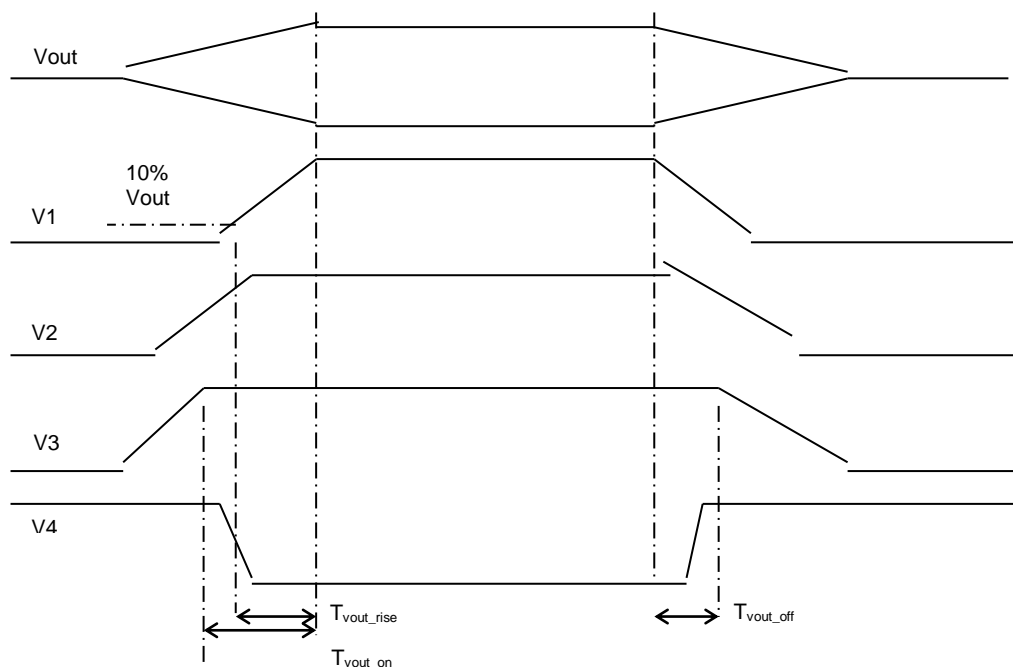

Figure 26. Output Voltage Timing

Table 45. Turn On/Off Timing

Item	Description	MIN	MAX	UNITS
T _{sb_on_delay}	Delay from AC being applied to 5VSB being within regulation.		1500	ms
T _{ac_on_delay}	Delay from AC being applied to all output voltages being within regulation.		2500	ms
T _{vout_holdup}	Time all output voltages stay within regulation after loss of AC. Tested at 75% of maximum load.	13		ms
T _{pwok_holdup}	Delay from loss of AC to de-assertion of PWOK. Tested at 75% of maximum load.	12		ms
T _{pson_on_delay}	Delay from PSON# active to output voltages within regulation limits.	5	400	ms
T _{pson_pwok}	Delay from PSON# deactivate to PWOK being de-asserted.		50	ms
T _{pwok_on}	Delay from output voltages within regulation limits to PWOK asserted at turn on.	100	500	ms
T _{pwok_off}	Delay from PWOK de-asserted to output voltages (3.3V, 5V, 12V, -12V) dropping out of regulation limits.	1		ms
T _{pwok_low}	Duration of PWOK being in the de-asserted state during an off/on cycle using AC or the PSON signal.	100		ms
T _{sb_vout}	Delay from 5VSB being in regulation to O/Ps being in regulation at AC turn on.	10	1000	ms
T _{5VSB_holdup}	Time the 5VSB output voltage stays within regulation after loss of AC.	70		ms

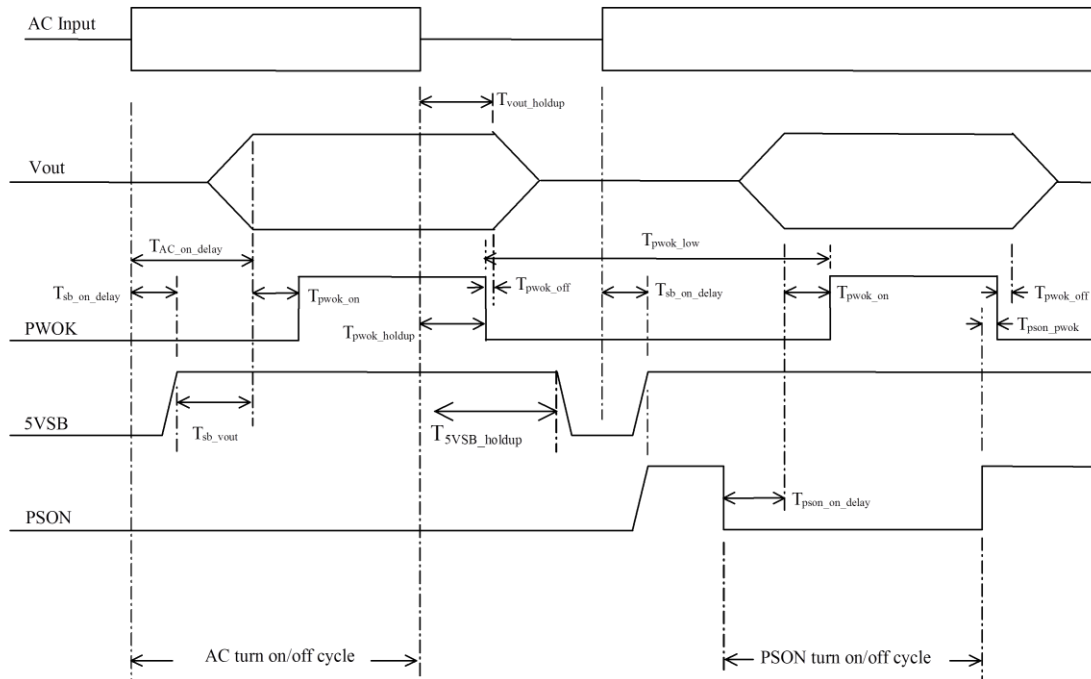

Figure 27. Turn On/Off Timing (Power Supply Signals)

2.2.6 Protection Circuits

Protection circuits inside the power supply causes only the power supply’s main outputs to shut down. If the power supply latches off due to a protection circuit tripping, an AC cycle OFF for 15sec and a PSON# cycle HIGH for 1sec able to reset the power supply.

2.2.6.1 Current Limit (OCP)

Below are over current protection limits for each output. If the current limits are exceeded the power supply shuts down and latch off. The latch will be cleared by toggling the PSON# signal or by an AC power interruption. The power supply does not be damaged from repeated power cycling in this condition. -12V and 5VSB is protected under over current or shorted conditions so that no damage can occur to the power supply. 5Vsb will be auto-recovered after removing OCP limit.

Table 46. Over Current Limits

Output	Min OCP	Max OCP
+3.3V	22 A	Meet 240VA
+5V	16 A	30 A
+12V1,2	29 A	36 A
+12V3 (240VA limited)	18.5 A	20 A
-12V	No damage	
5Vstby	No damage	

2.2.6.2 Over Voltage Protection (OVP)

The power supply over voltage protection is locally sensed. The power supply shuts down and latch off after an over voltage condition occurs. This latch is cleared by toggling the PSON#

signal or by an AC power interruption. The table below contains the over voltage limits. The values are measured at the output of the power supply's pins. The voltage shall never exceed the maximum levels when measured at the power pins of the power supply connector during any single point of fail. The voltage shall never trip any lower than the minimum levels when measured at the power pins of the power supply connector. 5VSB will be auto-recovered after removing OVP limit.

Table 24. Over Voltage Protection (OVP) Limits

Output Voltage	MAX (V)
+3.3V	4.5
+5V	6.5
+12V1,2,3	14.5
+5VSB	6.5

2.2.6.3 Over Temperature Protection (OTP)

The power supply will be protected against over temperature conditions caused by loss of fan cooling or excessive ambient temperature. In an OTP condition the PSU will shut down.

2.2.7 Control and Indicator Functions

The following sections define the input and output signals from the power supply.

Signals that can be defined as low true use the following convention: Signal# = low true

2.2.7.1 PSON# Input Signal

The PSON# signal is required to remotely turn on/off the power supply. PSON# is an active low signal that turns on the +3.3V, +5V, +12V1, +12V2, +12V3 and -12V power rails. When this signal is not pulled low by the system, or left open, the outputs (except the +5VSB) turn off. This signal is pulled to a standby voltage by a pull-up resistor internal to the power supply. Refer to Figure 27 for the timing diagram.

Table 47. PSON# Signal Characteristic

Signal Type	Accepts an open collector/drain input from the system. Pull-up to VSB located in power supply.	
PSON# = Low	ON	
PSON# = High or Open	OFF	
	MIN	MAX
Logic level low (power supply ON)	0V	1.0V
Logic level high (power supply OFF)	2.0V	5.25V
Source current, Vpson = low		4mA
Power up delay: Tpson_on_delay	5msec	400msec
PWOK delay: T pson_pwok		50msec

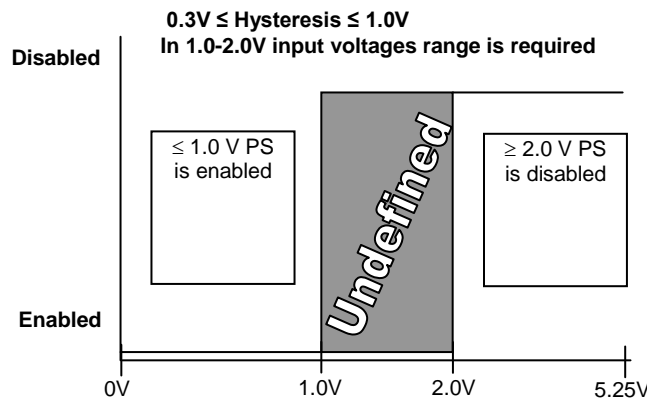

Figure 28. PSON# Required Signal Characteristic

2.2.7.2 PWOK (Power OK) Output Signal

PWOK is a power OK signal and will be pulled HIGH by the power supply to indicate that all the outputs are within the regulation limits of the power supply. When any output voltage falls below regulation limits or when AC power has been removed for a time sufficiently long so that power supply operation is no longer guaranteed, PWOK will be de-asserted to a LOW state. Refer to Figure 27 for a representation of the timing characteristics of PWOK. The start of the PWOK delay time shall inhibited as long as any power supply output is in current limit.

Table 48. PWOK Signal Characteristics

Signal Type	Open collector/drain output from power supply. Pull-up to VSB located in system.	
PWOK = High	Power OK	
PWOK = Low	Power Not OK	
	MIN	MAX
Logic level low voltage, Isink=4mA	0V	0.4V
Logic level high voltage, Isource=200µA	2.4V	5.25V
Sink current, PWOK = low		4mA
Source current, PWOK = high		2mA
PWOK delay: Tpwok_on	100ms	500ms
PWOK rise and fall time		100µsec
Power down delay: T pwok_off	1ms	

2.3 460W Power Supply

This specification defines a 460W redundant power supply that supports server systems. The parameters of this power supply are defined in this specification. This specification defines a power supply with 2 outputs; 12V and 12V standby. The AC input shall be auto ranging and power factor corrected.

2.3.1 Mechanical Overview

The physical size of the power supply enclosure is 39/40mm x 73.5mm x 185mm. The power supply contains a single 40mm fan. The power supply has a card edge output that interfaces with a 2x25 card edge connector in the system. The AC plugs directly into the external face of the power supply. Refer to the following figure. All dimensions are nominal.

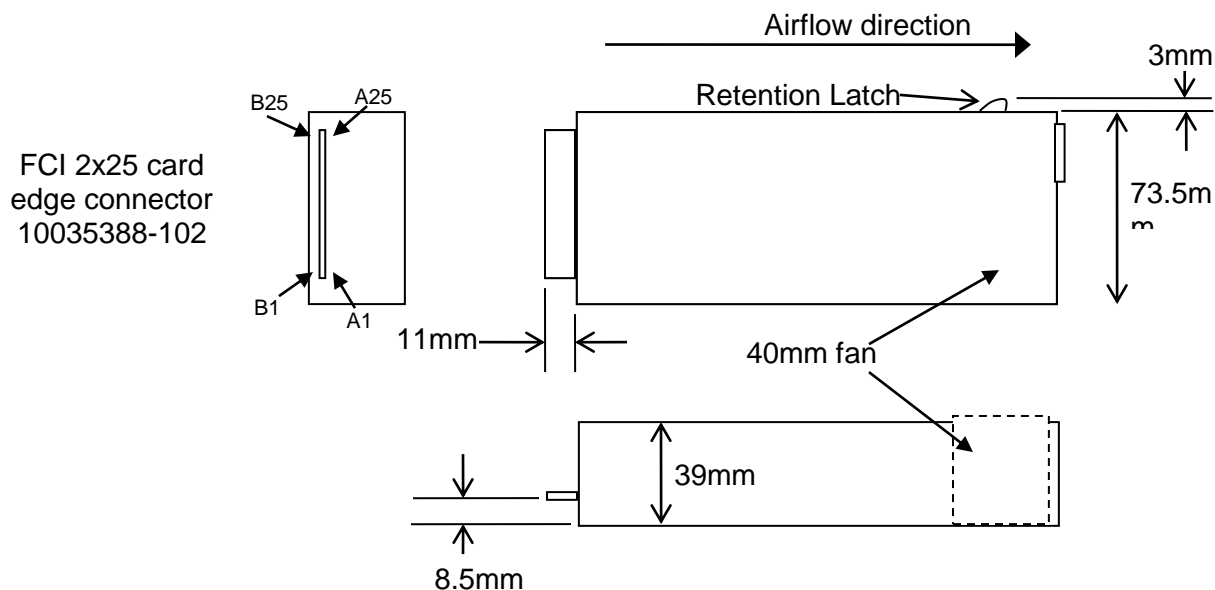

Figure 29. Power Supply Outline Drawing

2.3.1.1 DC Output Connector

The power supply shall use a card edge output connection for power and signal that is compatible with a 2x25 Power Card Edge connector (equivalent to 2x25 pin configuration of the FCI power card connector 10035388-102LF).

Table 49. DC Output Selector

Pin	Name	Pin	Name
A1	GND	B1	GND
A2	GND	B2	GND
A3	GND	B3	GND
A4	GND	B4	GND
A5	GND	B5	GND
A6	GND	B6	GND
A7	GND	B7	GND
A8	GND	B8	GND
A9	GND	B9	GND
A10	+12V	B10	+12V
A11	+12V	B11	+12V
A12	+12V	B12	+12V

Pin	Name	Pin	Name
A13	+12V	B13	+12V
A14	+12V	B14	+12V
A15	+12V	B15	+12V
A16	+12V	B16	+12V
A17	+12V	B17	+12V
A18	+12V	B18	+12V
A19	PMBus* SDA	B19	A0 (SMBus address)
A20	PMBus* SCL	B20	A1 (SMBus address)
A21	PSON	B21	12V stby
A22	SMBAlert#	B22	Cold Redundancy Bus
A23	Return Sense	B23	12V load share bus
A24	+12V remote Sense	B24	No Connect
A25	PWOK	B25	Compatibility Check pin*

Note: Refer to the *Common Hardware and Firmware Requirements for CRPS Power Supplies Specification*.

2.3.1.2 Handle Retention

The power supply shall have a handle to assist extraction. The module shall be able to be inserted and extracted without the assistance of tools. The power supply shall have a latch which retains the power supply into the system and prevents the power supply from being inserted or extracted from the system when the AC power cord is pulled into the power supply.

The handle shall protect the operator from any burn hazard through the use of the Intel Corporation Industrial designed plastic handle or equivalent Intel approved material.

2.3.1.3 LED Marking and Identification

The power supply shall use a bi-color LED; Amber and Green. Below are table showing the LED states for each power supply operating state and the LED's wavelength characteristics.

Refer to the Intel LED Wavelength and Intensity specification for more details.

Table 50. LED Characteristics

	Min λ_d Wavelength	Nominal λ_d Wavelength	Max λ_d Wavelength	Units
Green	562	565	568	nm
Amber	607	610	613	nm

Table 51. LED Indicator States

Power Supply Condition	LED State
Output ON and OK	GREEN
No AC power to all power supplies	OFF
AC present/Only 12VSB on (PS off) or PS in Cold redundant state	1Hz Blink GREEN
AC cord unplugged or AC power lost; with a second power supply in parallel still with AC input power.	AMBER

Power Supply Condition	LED State
Power supply warning events where the power supply continues to operate; high temp, high power, high current, slow fan.	1Hz Blink Amber
Power supply critical event causing a shutdown; failure, OCP, OVP, Fan Fail	AMBER
Power supply FW updating	2Hz Blink GREEN

2.3.1.4 Temperature Requirements

The power supply shall operate within all specified limits over the T_{op} temperature range. All airflow shall pass through the power supply and not over the exterior surfaces of the power supply.

Table 52. Environmental Requirements

Item	Description	MIN	MAX	UNITS
$T_{op_sc_red}$	Operating temperature range; spreadcore redundant (60% load, 3000m, spreadcore system flow impedance)	0	60	°C
$T_{op_sc_nr}$	Operating temperature range; spreadcore non-redundant (100% load, 3000m, spreadcore system flow impedance)	0	50	°C
$T_{op_rackped_900}$	Operating temperature range; rack/pedestal 900m (100% load, 900m, rack/pedestal system flow impedance)	0	45	°C
$T_{op_rackped_3000}$	Operating temperature range; rack/pedestal 3000m (100% load, 3000m, rack/pedestal system flow impedance)	0	40	°C
Texit	Maximum exit air temperature		68 ¹	°C
T_{non-op}	Non-operating temperature range.	-40	70	°C
Altitude	Maximum operating altitude		3050	m

2.3.2 AC Input Requirements

2.3.2.1 Power Factor

The power supply must meet the power factor requirements stated in the Energy Star® Program Requirements for Computer Servers. These requirements are stated below:

Output power	10% load	20% load	50% load	100% load
Power factor	> 0.65	> 0.80	> 0.90	> 0.95

Tested at 230Vac, 50Hz and 60Hz and 115VAC, 60Hz

Tested according to Generalized Internal Power Supply Efficiency Testing Protocol Rev 6.4.3.

This is posted at <http://efficientpowersupplies.epri.com/methods.asp>.

2.3.2.2 AC Inlet Connector

The AC input connector shall be an *IEC 320 C-14* power inlet. This inlet is rated for 10A/250VAC.

2.3.2.3 AC Input Voltage Specification

The power supply must operate within all specified limits over the following input voltage range. Harmonic distortion of up to 10% of the rated line voltage must not cause the power supply to go out of specified limits. Application of an input voltage below 85VAC shall not cause damage to the power supply, including a blown fuse.

Table 53. AC Input Voltage Range

Parameter	MIN	Rated	V _{MAX}	Startup VAC	Power Off VAC
Voltage (110)	90 V _{rms}	100-127 V _{rms}	140 V _{rms}	85VAC +/- 4VAC	74VAC +/- 5VAC
Voltage (220)	180 V _{rms}	200-240 V _{rms}	264 V _{rms}		
Frequency	47 Hz	50/60	63 Hz		

Notes:

1. Maximum input current at low input voltage range shall be measured at 90VAC, at max load.
2. Maximum input current at high input voltage range shall be measured at 180VAC, at max load.
3. This requirement is not to be used for determining agency input current markings.

2.3.2.4 AC Line Dropout/Holdup

An AC line dropout is defined to be when the AC input drops to 0VAC at any phase of the AC line for any length of time. During an AC dropout the power supply must meet dynamic voltage regulation requirements. An AC line dropout of any duration shall not cause tripping of control signals or protection circuits. If the AC dropout lasts longer than the holdup time the power supply should recover and meet all turn on requirements. The power supply shall meet the AC dropout requirement over rated AC voltages and frequencies. A dropout of the AC line for any duration shall not cause damage to the power supply.

Loading	Holdup time
70%	12msec

2.3.2.5 AC Line 12VSBHoldup

The 12VSB output voltage should stay in regulation under its full load (static or dynamic) during an AC dropout of **70ms min** (=12VSB holdup time) whether the power supply is in ON or OFF state (PSON asserted or de-asserted).

2.3.2.6 AC Line Fuse

The power supply shall have one line fused in the **single line fuse** on the line (Hot) wire of the AC input. The line fusing shall be acceptable for all safety agency requirements. The input fuse shall be a slow blow type. AC inrush current shall not cause the AC line fuse to blow under any conditions. All protection circuits in the power supply shall not cause the AC fuse to blow unless a component in the power supply has failed. This includes DC output load short conditions.

2.3.2.7 AC Line Transient Specification

AC line transient conditions shall be defined as “sag” and “surge” conditions. “Sag” conditions are also commonly referred to as “brownout”; these conditions will be defined as the AC line voltage dropping below nominal voltage conditions. “Surge” will be defined to refer to conditions when the AC line voltage rises above nominal voltage.

The power supply shall meet the requirements under the following AC line sag and surge conditions.

Table 54 AC Line Sag Transient Performance

AC Line Sag (10sec interval between each sagging)				
Duration	Sag	Operating AC Voltage	Line Frequency	Performance Criteria
0 to 1/2 AC cycle	95%	Nominal AC Voltage ranges	50/60Hz	No loss of function or performance
> 1 AC cycle	>30 %	Nominal AC Voltage ranges	50/60Hz	Loss of function acceptable, self-recoverable

Table 55. AC Line Surge Transient Performance

AC Line Surge				
Duration	Surge	Operating AC Voltage	Line Frequency	Performance Criteria
Continuous	10%	Nominal AC Voltages	50/60Hz	No loss of function or performance
0 to ½ AC cycle	30%	Mid-point of nominal AC Voltages	50/60Hz	No loss of function or performance

2.3.2.8 Power Recovery

The power supply shall recover automatically after an AC power failure. AC power failure is defined to be any loss of AC power that exceeds the dropout criteria.

2.3.3 Efficiency

The following table provides the required minimum efficiency level at various loading conditions. These are provided at three different load levels; 100%, 50%, 20%, and 10%. Output shall be load according to the proportional loading method defined by 80 Plus in Generalized Internal Power Supply Efficiency Testing Protocol Rev 6.4.3. This is posted at <http://efficientpowersupplies.epri.com/methods.asp>

Table 56. Gold Efficiency Requirement

Loading	100% of maximum	50% of maximum	20% of maximum	10% of maximum
Minimum Efficiency	88%	92%	88%	80%

The power supply must pass with enough margins to make sure in production all power supplies meet these efficiency requirements.

2.3.4 DC Output Specification

2.3.4.1 Output Power/Currents

The following table defines the minimum power and current ratings. The power supply must meet both static and dynamic voltage regulation requirements for all conditions.

Table 57. Minimum Load Ratings

Parameter	Min	Max.	Peak ^{2,3}	Unit
12V main	0.0	38.0	45.0	A
12Vstby ¹	0.0	2.1	2.4	A

Notes:

1. 12Vstby must provide 4.0A with two power supplies in parallel. The Fan may start to work when stby current >1.5A
2. Peak combined power for all outputs shall not exceed 575W.
3. Length of time peak power can be supported is based on thermal sensor and assertion of the SMBAlert# signal. Minimum peak power duration shall be 20 seconds without asserting the SMBAlert# signal at maximum operating temperature.

2.3.4.2 Standby Output

The 12VSB output shall be present when an AC input greater than the power supply turn on voltage is applied. There should be load sharing in the standby rail. And two PSU modules should be able to support 4A standby current.

2.3.4.3 Voltage Regulation

The power supply output voltages must stay within the following voltage limits when operating at steady state and dynamic loading conditions. These limits include the peak-peak ripple/noise. These shall be measured at the output connectors.

Table 58. Voltage Regulation Limits

Parameter	Tolerance	MIN	NOM	MAX	UNITS
+12V	- 5%/+5%	+11.40	+12.00	+12.60	V _{rms}
+12V stby	- 5%/+5%	+11.40	+12.00	+12.60	V _{rms}

2.3.4.4 Dynamic Loading

The output voltages shall remain within limits specified for the step loading and capacitive loading specified in the table below. The load transient repetition rate shall be tested between 50Hz and 5kHz at duty cycles ranging from 10%-90%. The load transient repetition rate is only a test specification. The Δ step load may occur anywhere within the MIN load to the MAX load conditions.

Table 59. Transient Load Requirements

Output	Δ Step Load Size(See note)	Load Slew Rate	Test capacitive Load
+12VSB	1.0A	0.25 A/ μ sec	20 μ F
+12V	60% of max load	0.25 A/ μ sec	2000 μ F

Note: For dynamic condition +12V min loading is 1A.

2.3.4.5 Capacitive Loading

The power supply shall be stable and meet all requirements with the following capacitive loading ranges.

Table 60. Capacitive Loading Conditions

Output	MIN	MAX	Units
+12VSB	20	3100	μF
+12V	500	25000	μF

2.3.4.6 Grounding

The output ground of the pins of the power supply provides the output power return path. The output connector ground pins shall be connected to the safety ground (power supply enclosure). This grounding should be well designed to ensure passing the max allowed Common Mode Noise levels.

The power supply shall be provided with a reliable protective earth ground. All secondary circuits shall be connected to protective earth ground. Resistance of the ground returns to chassis shall not exceed 1.0 mΩ. This path may be used to carry DC current.

2.3.4.7 Residual Voltage Immunity in Standby mode

The power supply should be immune to any residual voltage placed on its outputs (Typically a leakage voltage through the system from standby output) up to **500mV**. There shall be no additional heat generated, nor stressing of any internal components with this voltage applied to any individual or all outputs simultaneously. It also should not trip the protection circuits during turn on.

The residual voltage at the power supply outputs for no load condition shall not exceed **100mV** when AC voltage is applied and the PSON# signal is de-asserted.

2.3.4.8 Common Mode Noise

The Common Mode noise on any output shall not exceed **350mV pk-pk** over the frequency band of 10Hz to 20MHz.

1. The measurement shall be made across a 100Ω resistor between each of DC outputs, including ground at the DC power connector and chassis ground (power subsystem enclosure).
2. The test set-up shall use a FET probe such as Tektronix model P6046 or equivalent.

2.3.4.9 Hot Swap Requirements

Hot swapping a power supply is the process of inserting and extracting a power supply from an operating power system. During this process the output voltages shall remain within the limits with the capacitive load specified. The hot swap test must be conducted when the system is operating under static, dynamic, and zero loading conditions. The power supply shall use a latching mechanism to prevent insertion and extraction of the power supply when the AC power cord is inserted into the power supply.

2.3.4.10 Forced Load Sharing

The +12V output will have active load sharing. The output will share within 10% at full load. The failure of a power supply should not affect the load sharing or output voltages of the other supplies still operating. The supplies must be able to load share in parallel and operate in a hot-swap/redundant 1+1 configurations. The 12VSB output is not required to actively share current between power supplies (passive sharing). The 12VSB output of the power supplies are connected together in the system so that a failure or hot swap of a redundant power supply does not cause these outputs to go out of regulation in the system.

2.3.4.11 Ripple/Noise

The maximum allowed ripple/noise output of the power supply is defined in the table below. This is measured over a bandwidth of 10Hz to 20MHz at the power supply output connectors. A 10 μ F tantalum capacitor in parallel with a 0.1 μ F ceramic capacitor is placed at the point of measurement.

Table 61. Ripples and Noise

+12V main	+12VSB
120mVp-p	120mVp-p

The test set-up shall be as shown below.

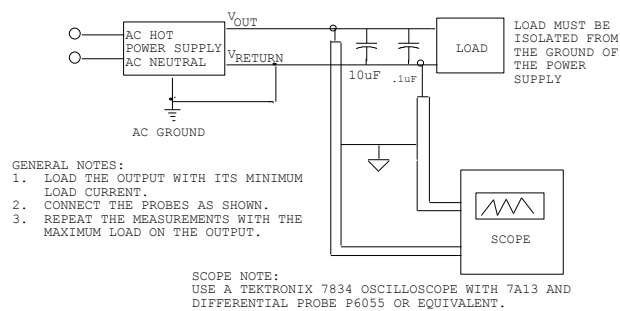

Figure 30. Differential Noise test setup

Note: When performing this test, the probe clips and capacitors should be located close to the load.

2.3.4.12 Timing Requirements

These are the timing requirements for the power supply operation. The output voltages must rise from 10% to within regulation limits (T_{vout_rise}) within 5 to 70ms. For 12VSB, it is allowed to rise from 1.0 to 25ms. **All outputs must rise monotonically.** Table below shows the timing requirements for the power supply being turned on and off by the AC input, with PSON held low and the PSON signal, with the AC input applied.

Table 62. Timing Requirements

Item	Description	MIN	MAX	UNITS
T_{vout_rise}	Output voltage rise time	5.0 *	70 *	ms
$T_{sb_on_delay}$	Delay from AC being applied to 12VSB being within regulation.		1500	ms
$T_{ac_on_delay}$	Delay from AC being applied to all output voltages being within regulation.		3000	ms
T_{vout_holdup}	Time 12V output voltage stays within regulation after loss of AC at 70% load.	13		ms
T_{pwok_holdup}	Delay from loss of AC to de-assertion of PWOK	12		ms
$T_{pson_on_delay}$	Delay from PSON# active to output voltages within regulation limits.	5	400	ms

Item	Description	MIN	MAX	UNITS
Tpson_pwok	Delay from PSON# deactivate to PWOK being de-asserted.		5	ms
Tpwok_on	Delay from output voltages within regulation limits to PWOK asserted at turn on.	100	500	ms
Tpwok_off	Delay from PWOK de-asserted to output voltages dropping out of regulation limits.	1		ms
Tpwok_low	Duration of PWOK being in the de-asserted state during an off/on cycle using AC or the PSON signal.	100		ms
Tsb_vout	Delay from 12VSB being in regulation to O/Ps being in regulation at AC turn on.	50	1000	ms
T12VSB_holdup	Time the 12VSB output voltage stays within regulation after loss of AC.	70		ms

* The 12VSB output voltage rise time shall be from 1.0ms to 25ms

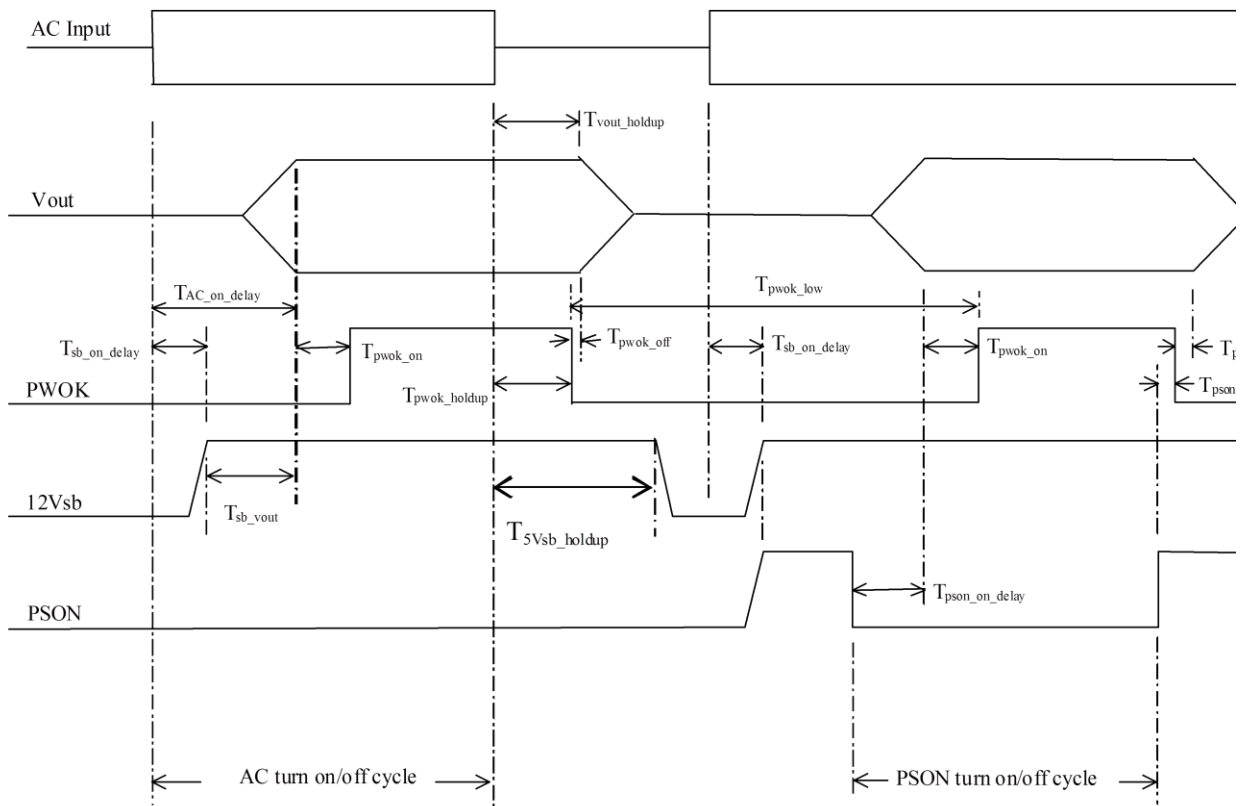

Figure 31. Turn On/Off Timing (Power Supply Signals)

2.3.5 Protection Circuits

Protection circuits inside the power supply shall cause only the power supply's main outputs to shut down. If the power supply latches off due to a protection circuit tripping, an AC cycle OFF for 15sec and a PSON# cycle HIGH for 1sec shall be able to reset the power supply.

2.3.5.1 Current Limit (OCP)

The power supply shall have current limit to prevent the outputs from exceeding the values shown in table below. If the current limits are exceeded the power supply shall shutdown and latch off. The latch will be cleared by toggling the PSON[#] signal or by an AC power interruption. The power supply shall not be damaged from repeated power cycling in this condition. 12VSB will be auto-recovered after removing OCP limit.

Table 63. Over Current Protection

Output VOLTAGE	Input voltage range	Over Current Limits
+12V	90 – 264VAC	47A min; 55A max
12VSB	90 – 264VAC	2A min; 2.5A max

2.3.5.2 Over Voltage Protection (OVP)

The power supply over voltage protection shall be locally sensed. The power supply shall shutdown and latch off after an over voltage condition occurs. This latch shall be cleared by toggling the PSON[#] signal or by an AC power interruption. The values are measured at the output of the power supply's connectors. The voltage shall never exceed the maximum levels when measured at the power connectors of the power supply connector during any single point of fail. The voltage shall never trip any lower than the minimum levels when measured at the power connector. 12VSB will be auto-recovered after removing OVP limit.

Table 64. Over Voltage Protection (OVP) Limits

Output Voltage	MIN (V)	MAX (V)
+12V	13.3	14.5
+12VSB	13.3	14.5

2.3.5.3 Over Temperature Protection (OTP)

The power supply will be protected against over temperature conditions caused by loss of fan cooling or excessive ambient temperature. In an OTP condition the PSU will shut down. When the power supply temperature drops to within specified limits, the power supply shall restore power automatically, while the 12VSB remains always on. The OTP circuit must have built in margin such that the power supply will not oscillate on and off due to temperature recovering condition. The OTP trip level shall have a minimum of 4°C of ambient temperature margin.

2.3.6 Control and Indicator Functions

The following sections define the input and output signals from the power supply. Signals that can be defined as low true use the following convention: *Signal[#]* = low true

2.3.6.1 PSON[#] Input Signal

The PSON[#] signal is required to remotely turn on/off the power supply. PSON[#] is an active low signal that turns on the +12V power rail. When this signal is not pulled low by the system, or left open, the outputs (except the +5VSB) turn off. This signal is pulled to a standby voltage by a pull-up resistor internal to the power supply. Refer figure 31 for the timing diagram.

Table 65. PSON# Signal Characteristic

Signal Type	Accepts an open collector/drain input from the system. Pull-up to VSB located in power supply.	
PSON# = Low	ON	
PSON# = High or Open	OFF	
	MIN	MAX
Logic level low (power supply ON)	0V	1.0V
Logic level high (power supply OFF)	2.0V	3.46V
Source current, V _{pson} = low		4mA
Power up delay: T _{pson_on_delay}	5msec	400msec
PWOK delay: T _{pson_pwok}		50msec

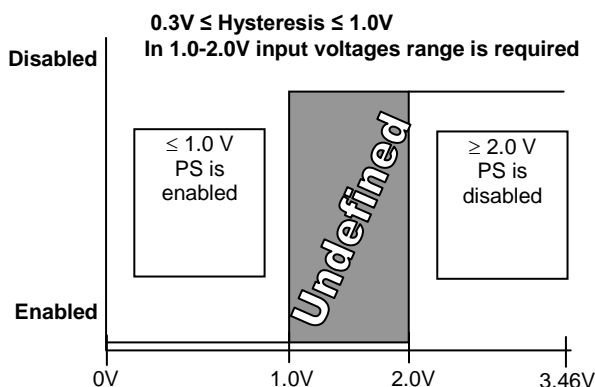

Figure 32. PSON# Required Signal Characteristic

2.3.6.2 PWOK (Power OK) Output Signal

PWOK is a power OK signal and will be pulled HIGH by the power supply to indicate that all the outputs are within the regulation limits of the power supply. When any output voltage falls below regulation limits or when AC power has been removed for a time sufficiently long so that power supply operation is no longer guaranteed, PWOK will be de-asserted to a LOW state. See the table below for a representation of the timing characteristics of PWOK. The start of the PWOK delay time shall be inhibited as long as any power supply output is in current limit.

Table 66. PWOK Signal Characteristics

Signal Type	Open collector/drain output from power supply. Pull-up to VSB located in the power supply.	
PWOK = High	Power OK	
PWOK = Low	Power Not OK	
	MIN	MAX
Logic level low voltage, I _{sink} =400uA	0V	0.4V
Logic level high voltage, I _{source} =200uA	2.4V	3.46V
Sink current, PWOK = low		400uA

Signal Type	Open collector/drain output from power supply. Pull-up to VSB located in the power supply.	
Source current, PWOK = high		2mA
PWOK delay: T_{pwok_on}	100ms	1000ms
PWOK rise and fall time		100µsec
Power down delay: T_{pwok_off}	1ms	200msec

A recommended implementation of the Power Ok circuits is shown below.

Note: The Power Ok circuits should be compatible with 5V pull up resistor (>10k) and 3.3V pull up resistor (>6.8k).

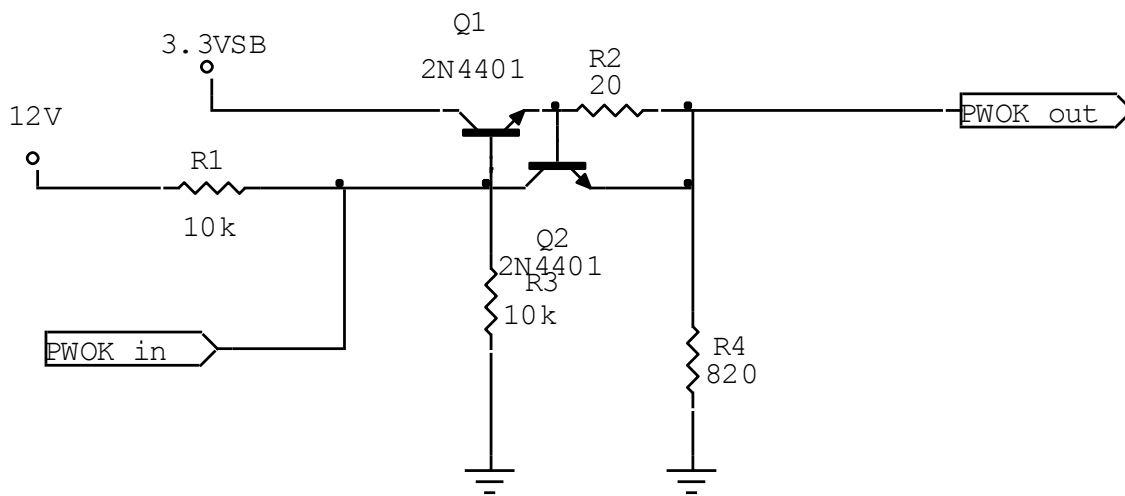

Figure 33. Implementation of the Power Ok Circuits

2.3.6.3 SMBAlert# Signal

This signal indicates that the power supply is experiencing a problem that the user should investigate. This shall be asserted due to Critical events or Warning events. The signal shall activate in the case of critical component temperature reached a warning threshold, general failure, over-current, over-voltage, under-voltage, failed fan. This signal may also indicate the power supply is reaching its end of life or is operating in an environment exceeding the specified limits.

This signal is to be asserted in parallel with LED turning solid Amber or blink Amber.

Table 67. SMBAlert# Signal Characteristics

Signal Type (Active Low)	Open collector/drain output from power supply. Pull-up to VSB located in system.	
Alert# = High	OK	
Alert# = Low	Power Alert to system	
	MIN	MAX
Logic level low voltage, Isink=4 mA	0 V	0.4 V
Logic level high voltage, Isink=50 μ A		3.46 V
Sink current, Alert# = low		4 mA
Sink current, Alert# = high		50 μ A
Alert# rise and fall time		100 μ s

2.3.7 Thermal CLST

The power supply shall assert the SMBAlert signal when a temperature sensor crosses a warning threshold. Refer to the *Intel® Common Hardware and Firmware Requirements for CRPS Power Supplier* for detailed requirements.

2.3.8 Power Supply Diagnostic “Black Box”

The power supply shall save the latest PMBus* data and other pertinent data into nonvolatile memory when a critical event shuts down the power supply. This data shall be accessible from the SMBus interface with an external source providing power to the 12Vstby output.

Refer to *Intel® Common Hardware and Firmware Requirements for CRPS Power Supplier* for detailed requirements.

2.3.9 Firmware Uploader

The power supply shall have the capability to update its firmware from the PMBus* interface while it is in standby mode. This FW can be updated when in the system and in standby mode and outside the system with power applied to the 12Vstby pins.

Refer to the *Intel® Common Hardware and Firmware Requirements for CRPS Power Supplier* for detailed requirements.

2.4 Lower Current Common Redundant Power Distribution Board (PDB)

The Power Distribution Board (PDB) for Intel® Server Chassis P4000M supports the Common Redundant power supply in a 1+1 redundant configuration. The PDB is designed to plug directly to the output connector of the PS and it contains 4 DC/DC power converters to produce other required voltages: -12V, +3.3VDC, +5VDC and 5V standby along with additional over current protection circuit for the 12V rails.

This power distribution board is intended to be used in the Intel® Server Chassis P4000M Family with various common redundant power supplies: 460W, 750W and DC input 750W.

2.4.1 Mechanical Overview

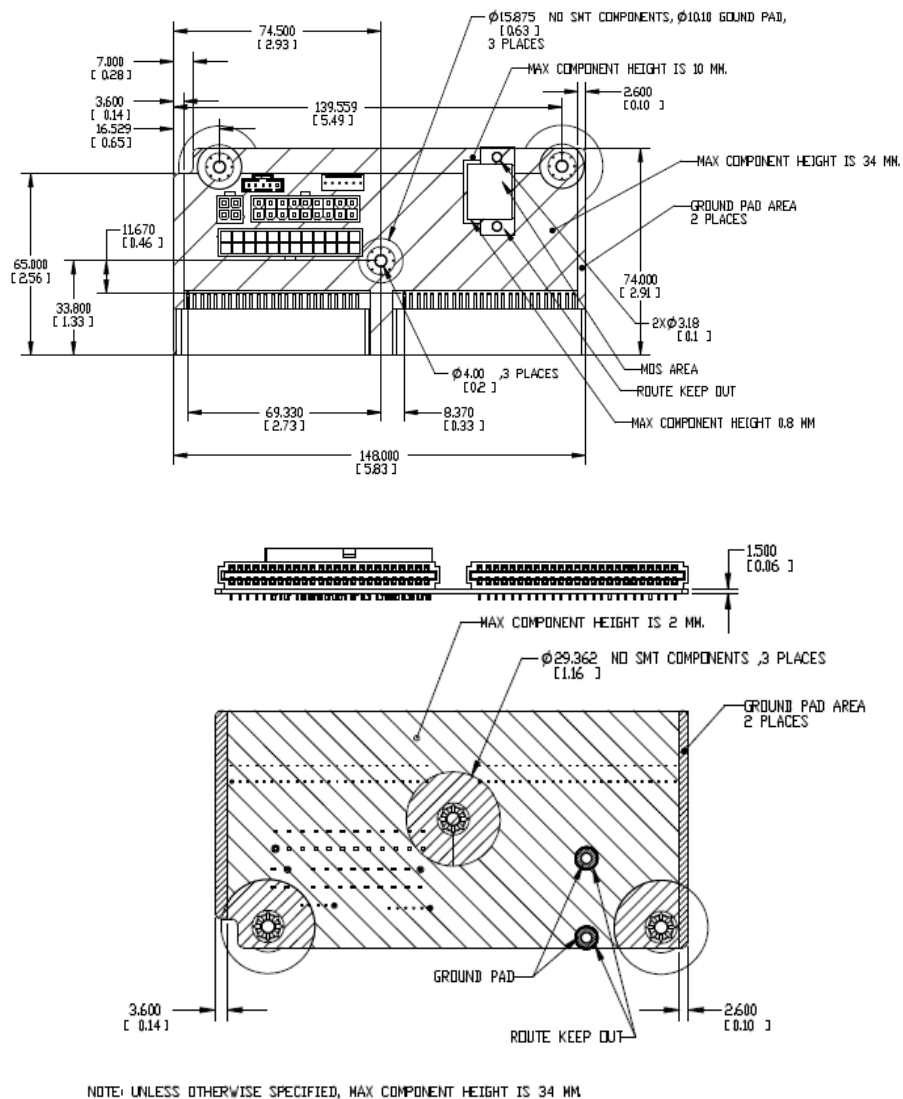

Figure 34. Outline Drawing

2.4.1.1 Airflow Requirements

The power distribution board shall get enough airflow for cooling DC/DC converters from the fans located in the Power Supply modules. Below is a basic drawing showing airflow direction.

The amount of cooling airflow that will be available to the DC/DC converters is to be no less than 1.2M/s.

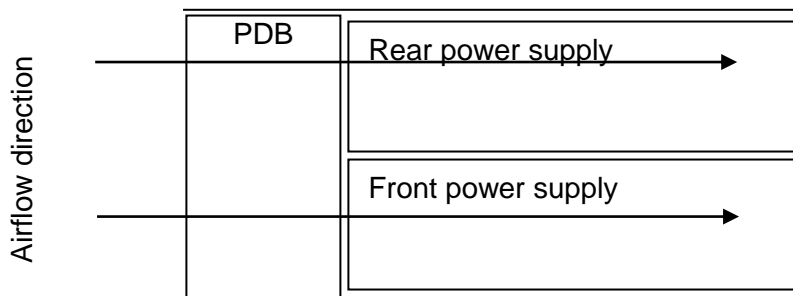

Figure 35. Airflow Diagram

2.4.1.2 DC/DC converter cooling

The dc/dc converters on the power distribution board are in series airflow path with the power supplies.

2.4.1.3 Temperature Requirements

The PDB operates within all specified limits over the Top temperature range. Some amount of airflow shall pass over the PDB.

Table 68. Thermal Requirements

Item	Description	Min	Max	Units
T _{op}	Operating temperature range.	0	50	°C
T _{non-op}	Non-operating temperature range.	-40	70	°C

2.4.1.4 Efficiency

Each DC/DC converter shall have a **minimum** efficiency of **85%** at 50% ~ 100% loads and over +12V line voltage range and over temperature and humidity range.

2.4.2 DC Output Specification

2.4.2.1 Input Connector (power distribution mating connector)

The power distribution provides 2 power pin, a card edge output connection for power and signal that is compatible with a 2x25 Power Card Edge connector (equivalent to 2x25 pin configuration of the FCI power card connector 10035388-102LF). The FCI power card edge connector is a new version of the PCE from FCI used to raise the card edge by 0.031" to allow for future 0.093" PCBs in the system. The card edge connector has no keying features; the keying method is accomplished by the system sheet metal.

Table 69. Input Connector and Pin Assignment Diagrams

Pin	Name	Pin	Name
A1	GND	B1	GND
A2	GND	B2	GND
A3	GND	B3	GND
A4	GND	B4	GND
A5	GND	B5	GND
A6	GND	B6	GND
A7	GND	B7	GND
A8	GND	B8	GND
A9	GND	B9	GND
A10	+12V	B10	+12V
A11	+12V	B11	+12V
A12	+12V	B12	+12V
A13	+12V	B13	+12V
A14	+12V	B14	+12V
A15	+12V	B15	+12V
A16	+12V	B16	+12V
A17	+12V	B17	+12V
A18	+12V	B18	+12V
A19	PMBus* SDA	B19	A0 (SMBus address)
A20	PMBus* SCL	B20	A1 (SMBus address)
A21	PSON	B21	12V stby
A22	SMBAlert#	B22	Cold Redundancy Bus
A23	Return Sense	B23	12V load share
A24	+12V remote Sense	B24	No Connect
A25	PWOK	B25	Compatibility Pin

2.4.2.2 Output Wire Harness

The power distribution board has a wire harness output with the following connectors.

Listed or recognized component appliance wiring material (AVLV2), CN, rated min 85°C shall be used for all output wiring.

Table 70. PDB Cable Length

From	Length, mm	To connector #	No. of pins	Description
Power Supply cover exit hole	470	P1	24	Baseboard Power Connector
Power Supply cover exit hole	320	P2	8	Processor 0 connector
Power Supply cover exit hole	450	P3	8	Processor 1 connector
Power Supply cover exit hole	800	P4	5	Power FRU/PMBus* connector
Power Supply cover exit hole	350	P5	5	SATA peripheral power connector for 5.25"
Extension from P5	100	P6	5	SATA peripheral power connector for 5.25"
Extension from P6	100	P7	4	Peripheral Power Connector for 5.25"/HSBP Power
Power Supply cover exit hole	400	P8	4	1x4 legacy HSBP Power Connector
Extension from P8	75	P9	4	1x4 legacy HSBP Power Connector

From	Length, mm	To connector #	No. of pins	Description
Power supply cover exit hole	500	P10	4	1x4 legacy HSBP Power/Fixed HDD adaptor Connection
Extension from P10	75	P11	4	1x4 legacy HSBP Power/Fixed HDD adaptor Connection
Connector only (no cable)		P12	4	2x2 Legacy PCI Power Connector for PCIe slots

2.4.2.2.1 Baseboard power connector (P1)

- Connector housing: 24-Pin Molex Mini-Fit Jr. 39-01-2245 or equivalent
- Contact: Molex Mini-Fit, HCS Plus, Female, Crimp 44476 or equivalent

Table 71. P1 Baseboard Power Connector

Pin	Signal	18 AWG Color	Pin	Signal	18 AWG Color
1	+3.3VDC	Orange	13	+3.3VDC	Orange
	3.3V RS	Orange (24AWG)			
2	+3.3VDC	Orange	14	-12VDC	Blue
3	COM	Black	15	COM	Black
4	+5VDC	Red	16	PSON#	Green (24AWG)
5	COM	Black	17	COM	Black
6	+5VDC	Red	18	COM	Black
7	COM	Black	19	COM	Black
8	PWR OK	Gray (24AWG)	20	Reserved	N.C.
9	5 VSB	Purple	21	+5VDC	Red
10	+12V1	Yellow	22	+5VDC	Red
11	+12V1	Yellow	23	+5VDC	Red
12	+3.3VDC	Orange	24	COM	Black

2.4.2.2.2 Processor#0 Power Connector (P2)

- Connector housing: 8-Pin Molex 39-01-2080 or equivalent
- Contact: Molex Mini-Fit, HCS Plus, Female, Crimp 44476 or equivalent

Table 72. P0 Processor Power Connector

Pin	Signal	18 AWG color	Pin	Signal	18 AWG Color
1	COM	Black	5*	+12V1	Yellow
2	COM	Black	6	+12V1	Yellow
3	COM	Black	7	+12V1	Yellow
4	COM	Black	8	+12V1	Yellow

2.4.2.2.3 Processor#1 Power Connector (P3)

- Connector housing: 8-Pin Molex 39-01-2080 or equivalent
- Contact: Molex Mini-Fit, HCS Plus, Female, Crimp 44476 or equivalent

Table 73. P1 Processor Power Connector

Pin	Signal	18 AWG color	Pin	Signal	18 AWG Color
1	COM	Black	5	+12V1	Yellow
2	COM	Black	6	+12V1	Yellow
3	COM	Black	7	+12V1	Yellow
4	COM	Black	8	+12V1	Yellow

2.4.2.2.4 Power Signal Connector (P4)

- Connector housing: 5-pin Molex 50-57-9405 or equivalent
- Contacts: Molex 16-02-0087 or equivalent

Table 74. Power Signal Connector

Pin	Signal	24 AWG Color
1	I2C Clock	White
2	I2C Data	Yellow
3	SMBAlert#	Red
4	COM	Black
5	3.3RS	Orange

2.4.2.2.5 Aux baseboard power connector (P12)

Connector header: Foxconn p/n HM3502E-P1 or equivalent

Table 75. Aux baseboard power connector

Pin	Signal	18 AWG color	Pin	Signal	18 AWG Color
1	COM	Black	3	+12V1	Yellow
2	COM	Black	4	+12V1	Yellow

2.4.2.2.6 Legacy 1x4 Peripheral Power Connectors (P7, P8, P9, P10, P11)

- Connector housing: Molex 0015-24-4048 or equivalent;
- Contact: Molex 0002-08-1201 or equivalent

Table 76. P8, P9, P10, P11 Legacy Peripheral Power Connectors

Pin	Signal	18 AWG Color
1	+12V3	White
2	COM	Black
3	COM	Black
4	+5 VDC	Red

Table 77. P7 Legacy Peripheral Power Connectors

Pin	Signal	18 AWG Color
1	+12V2	Brown
2	COM	Black
3	COM	Black
4	+5 VDC	Red

2.4.2.2.7 SATA 1x5 Peripheral Power Connectors (P5, P6)

- Connector housing: Molex 0675-82-0000 or equivalent;
- Contact: Molex 0675-81-0000 or equivalent

Table 78. SATA Peripheral Power Connectors

Pin	Signal	18 AWG Color
1	+3.3VDC	Orange
2	COM	Black
3	+5VDC	Red
4	COM	Black
5	+12V2	Brown

2.4.2.3 Grounding

The ground of the pins of the PDB output connectors provides the power return path. The output connector ground pins is connected to safety ground (PDB enclosure). This grounding is well designed to ensure passing the max allowed Common Mode Noise levels.

2.4.2.4 Remote Sense

Below is listed the remote sense requirements and connection points for all the converters on the PDB and the main 12V output of the power supply.

Table 79. Remote Sense Connection Points

Converter	+ sense location	- sense location
Power supply main 12V	On PDB	On PDB
12V/3.3V	P20 (1x5 signal connector)	P20 (1x5 signal connector)
12V/5V	On PDB	On PDB
12V/-12V	none	none
12Vstby/5Vstby	none	none

Table 80. Remote Sense Requirements

Characteristic	Requirement
+3.3V remote sense input impedance	200Ω (measure from +3.3V on P1 2x12 connector to +3.3V sense on P20 1x5 signal connector)
+3.3V remote sense drop	200mV (remote sense must be able to regulate out 200mV drop on the +3.3V and return path; from the 2x12 connector to the remote sense points)
Max remote sense current draw	< 5mA

2.4.2.5 12V Rail Distribution

The below table shows the configuration of the 12V rails and what connectors and components in the system they are powering.

Table 81. 12V Rail Distribution

	P2		P3		P12	P1	P8	P9	P10	P11	P5,6,7				
			2x4		2x2	2x12	1x4	1x4	1x4	1x4	(2) 1x5, 1x4	OCP			
	CPU1	Memory1	CPU2	Memory2	PCIe	Fans	Misc	HDD and peripherals				Total Current	Min	Nominal	Max
12V1	17.8 A	10.5 A	17.8	10.5	21.7	10.0 A	3.0 A					91 A	50	55	60
12V2								18.0 A (P8, 9, 10, 11)				18 A	18	19	20
12V3								18a (P5, 6, 7)				18 A	18	19	20

Note:

+12V current to PCIe slots may be supplied from four different connectors. 12V1 on P2, 12V2 on P3, 12V3 on P1, and 12V3 on P12. P12 is reserved for board that needs 4 x GPU cards powered. P1 is the main 12V power for PCIe slot; but additional 12V power can be connected to P2 and/or P3. The motherboard MUST NOT short any of the 12V rails or connectors together.

2.4.2.6 Hard Drive 12V rail configuration options

The below table shows the hard drive configuration options using the defined power connectors. In some cases additional converter or 'Y' cables are needed.

Table 82. Hard Drive 12V rail configuration options

	P8	P9	P10	P11	P5	P6	P7
	1x4	1x4	1x4	1x4	1x5	1x5	1x4
	18						
3 x 2.5" 8xHDD BP	HDD1 8 x 2.5	HDD2 8 x 2.5	na	na	na	na	HDD3 8 x 2.5
2 x 3.5" 4xHDD BP	HDD1 4x3.5		HDD1 4x3.5		peripheral bay		
1 x 3.5" 8xHDD BP	HDD1 8x3.5		na	na	peripheral bay		
8 x 3.5" fixed SATA	2xfixed	2xfixed	2xfixed	2xfixed	peripheral bay		
8 x 3.5" fixed SAS	2xfixed	2xfixed	2xfixed	2xfixed	peripheral bay		

2.4.2.7 DC/DC Converters Loading

The following table defines power and current ratings of three DC/DC converters located on the PDB, each powered from +12V rail. The 3 converters meet both static and dynamic voltage regulation requirements for the minimum and maximum loading conditions.

Table 83. DC/DC Converters Load Ratings

	+12VDC Input DC/DC Converters		
	+3.3V Converter	+5V Converter	-12V Converter
MAX Load	15A	15A	0.5A
MIN Static/Dynamic Load	0A	0A	0A
Max Output Power	3.3V x15A =49.5W	5V x15A =75W	12V x0.5A =6W

2.4.2.8 5VSB Loading

There is also one DC/DC converter that converts the 12V standby into 5V standby.

Table 84. 5VSB Loading

	12V stby/5V stby DC/DC Converters
MAX Load	5A
MIN Static/Dynamic Load	0.1
Max Output Power	5V x5A =25W

2.4.2.9 DC/DC Converters Voltage Regulation

The DC/DC converters' output voltages stay within the following voltage limits when operating at steady state and dynamic loading conditions. These limits include the peak-peak ripple/noise specified in Table 88. The 3.3V and 5V outputs are measured at the remote sense point, all other voltages measured at the output harness connectors.

Table 85. Voltage Regulation Limits

Converter output	Tolerance	Min	Nom	Max	Units
+ 3.3VDC	-5%/+5%	+3.14	+3.30	+3.46	VDC
+ 5VDC	-5%/+5%	+4.75	+5.00	+5.25	VDC
- 12VDC	- 5%/+9%	-13.08	-12.00	-11.40	VDC
5Vstby	-5%/+5%	+4.75	+5.00	+5.25	VDC

2.4.2.10 DC/DC Converters Dynamic Loading

The output voltages remains within limits specified in table above for the step loading and capacitive loading specified in Table 103 below. The load transient repetition rate is only a test specification. The Δ step load may occur anywhere within the MIN load to the MAX load shown in

Table 83 and Table 84.

Table 86. Transient Load Requirements

Output	Max Δ Step Load Size	Max Load Slew Rate	Test capacitive Load
+ 3.3VDC	5A	0.25 A/ μ s	250 μ F
+ 5VDC	5A	0.25 A/ μ s	400 μ F
+5Vsb	0.5A	0.25A/ μ s	20 μ F

2.4.2.11 DC/DC Converter Capacitive Loading

The DC/DC converters are stable and meet all requirements with the following capacitive loading ranges.

Min capacitive loading applies to static load only.

Table 87. Capacitive Loading Conditions

Converter output	Min	Max	Units
+3.3VDC	250	6800	μF
+5VDC	400	4700	μF
-12VDC	1	350	μF
5Vstby	20	350	μF

2.4.2.12 DC/DC Converters Closed Loop stability

Each DC/DC converter is unconditionally stable under all line/load/transient load conditions including capacitive load ranges specified in Section 2.5.2.11. A minimum of: **45 degrees phase margin** and **-10dB-gain margin** is required. The PDB provides proof of the unit's closed-loop stability with local sensing through the submission of Bode plots. Closed-loop stability must be ensured at the maximum and minimum loads as applicable.

2.4.2.13 Common Mode Noise

The Common Mode noise on any output does not exceed 350mV pk-pk over the frequency band of 10Hz to 20MHz.

- The measurement shall be made across a 100Ω resistor between each of DC outputs, including ground, at the DC power connector and chassis ground (power subsystem enclosure).
- The test set-up shall use a FET probe such as Tektronix model P6046 or equivalent.

2.4.2.14 Ripple/Noise

The maximum allowed ripple/noise output of each DC/DC Converter is defined in the table below. This is measured over a bandwidth of 0Hz to 20MHz at the PDB output connectors. A 10μF tantalum capacitor in parallel with a 0.1μF ceramic capacitor are placed at the point of measurement.

Table 88. Ripple and Noise

+3.3V	+5V	-12V	+5VSB
50mVp-p	50mVp-p	120mVp-p	50mVp-p

The test set-up shall be as shown below.

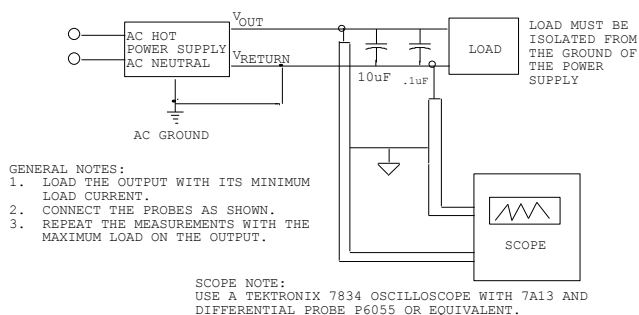

Figure 36. Differential Noise test setup

Note: When performing this test, the probe clips and capacitors should be located close to the load.

2.4.2.15 Timing Requirements

Below are timing requirements for the power on/off of the PDB DC/DC converters. The +3.3V, +5V and +12V output voltages should start to rise approximately at the same time. All outputs must rise monotonically.

Table 89. Output Voltage Timing

Description	Min	Max	Units
Output voltage rise time for each main output; 3.3V, 5V, and -12V.	5.0	70	msec
Output voltage rise time for the 5Vstby	1.0	25	msec
The main DC/DC converters (3.3V, 5V, -12V) shall be in regulation limits within this time after the 12V input has reached 11.4V.		50	msec
The main DC/DC converters (3.3V, 5V, -12V) must power off within this time after the 12V input has dropped below 11.4V.		100	msec
The 5Vstby converter shall be in regulation limits within this time after the 12Vstby has reach 11.4V.		10	msec
The 5Vstby converter must power off within this time after the 12Vstby input has dropped below 11.4V.		100	msec

2.4.2.16 Residual Voltage Immunity in Standby Mode

Each DC/DC converter is immune to any residual voltage placed on its respective output (typically a leakage voltage through the system from standby output) up to 500mV. This residual voltage does not have any adverse effect on each DC/DC converter, such as: no additional power dissipation or over-stressing/over-heating any internal components or adversely affecting the turn-on performance (no protection circuits tripping during turn on).

While in Stand-by mode, at no load condition, the residual voltage on each DC/DC converter output does not exceed 100mV.

2.4.3 Protection Circuits

The PDB shall shut down all the DC/DC converters on the PDB and the power supply (from PSON) if there is a fault condition on the PDB (OVP or OCP). If the PDB DC/DC converter

latches off due to a protection circuit tripping, an AC cycle OFF for 15sec min or a PSON# cycle HIGH for 1sec shall be able to reset the power supply and the PDB.

2.4.3.1 Over-Current Protection (OCP)/240VA Protection

Each DC/DC converter output on PDB has individual OCP protection circuits. The PS+PDB combo shall shutdown and latch off after an over current condition occurs. This latch shall be cleared by toggling the PSON# signal or by an AC power interruption. The values are measured at the PDB harness connectors. The DC/DC converters shall not be damaged from repeated power cycling in this condition. Also, the +12V output from the power supply is divided on the PDB into 4 channels and +12V4 is limited to 240VA of power. There are current sensors and limit circuits to shut down the entire PS+PDB combo if the limit is exceeded. The limits are listed in below table. -12V and 5VSB is protected under over current or shorted conditions so that no damage can occur to the power supply. Auto-recovery feature is a requirement on 5VSB rail.

Table 90. PDB Over Current Protection Limits/240VA Protection

Output Voltage	Min OCP Trip Limits	Max OCP Trip Limits	Usage	Connectors
+3.3V	18A	240VA	PCIe, Misc	P1
+5V	18A	240VA	PCIe, HDD, Misc	P1, P5-11
+12V1	91A	100A	CPU1 + memory Fans, Misc	P2
+12V2	18A	20A	HDD and peripherals	P8, 9, 10, 11
+12V3	18A	20A	HDD and peripherals	P5, 6, 7

2.4.3.2 Over Voltage Protection (OVP)

Each DC/DC converter output on PDB have individual OVP protection circuits built in and it shall be locally sensed. The PS+PDB combo shall shutdown and latch off after an over voltage condition occurs. This latch shall be cleared by toggling the PSON# signal or by an AC power interruption. Table 91 contains the over voltage limits. The values are measured at the PDB harness connectors. The voltage shall never exceed the maximum levels when measured at the power pins of the output harness connector during any single point of fail. The voltage shall never trip any lower than the minimum levels when measured at the power pins of the PDB connector.

Table 91. Over Voltage Protection (OVP) Limits

Output voltage	OVP min (v)	OVP max (v)
+3.3V	3.9	4.8
+5V	5.7	6.5
-12V	-13.3	-15.5
+5VSB	5.7	6.5

2.4.4 PWOK (Power OK) Signal

The PDB connects the PWOK signals from the power supply modules and the DC/DC converters to a common PWOK signal. This common PWOK signal connects to the PWOK pin on P1. The DC/DC convert PWOK signals have open collector outputs.

2.4.4.1 System PWOK requirements

The system will connect the PWOK signal to 3.3V or 5V from a pull-up resistor. The maximum sink current of the power supplies are 0.5mA. The minimum resistance of the pull-up resistor is

stated below depending upon the motherboard's pull-up voltage. Refer to the CRPS power supply specification for signal details.

Table 92. System PWOK Requirements

Motherboard pull-up voltage	MIN resistance value (ohms)
5V	10K
3.3V	6.8K

2.4.5 PSON Signal

The PDB connects the power supplies PSON signals together and connect them to the PSON signal on P1.

Refer to the CRPS power supply specification for signal details.

2.4.6 PMBus*

The PDB has no components on it to support PMBus*. It only needs to connect the power supply PMBus* signals (clock, data, SMBAlert#) and pass them to the 1x5 signal connector.

2.4.6.1 Addressing

The PDB address the power supply as follows on the PDB.

0 = open, 1 = grounded

Table 93. PDB addressing

	Power Supply Position 1	Power Supply Position 2
PDB addressing Address0/Address1	0/0	0/1
Power supply PMBus* device address	B0h	B2h

3. Chassis Cooling

The Intel® Server Chassis P4000S family is engineered to provide sufficient cooling for all internal components of the server. The cooling subsystem is dependent upon proper airflow. The designated cooling vents on both the front and back of the chassis must be left open and must not be blocked by improperly installed devices. All internal cables must be routed in a manner that does not impede airflow, and ducting provided for CPU cooling must be installed.

3.1 Cooling solution for Intel® Server Board S1200BT Series

The cooling solution for Intel® Server Board S1200BT series in Intel® Server Chassis P4000S family consists of one 92x38 mm rear system fan and one power supply fan. The 4-wire/4-pin 92mm x 38mm system fan is designed to plug into a 4-pin SSI fan headers, provides cooling at the rear of the chassis by drawing fresh air into the chassis from the front and exhausting warm air out the system.

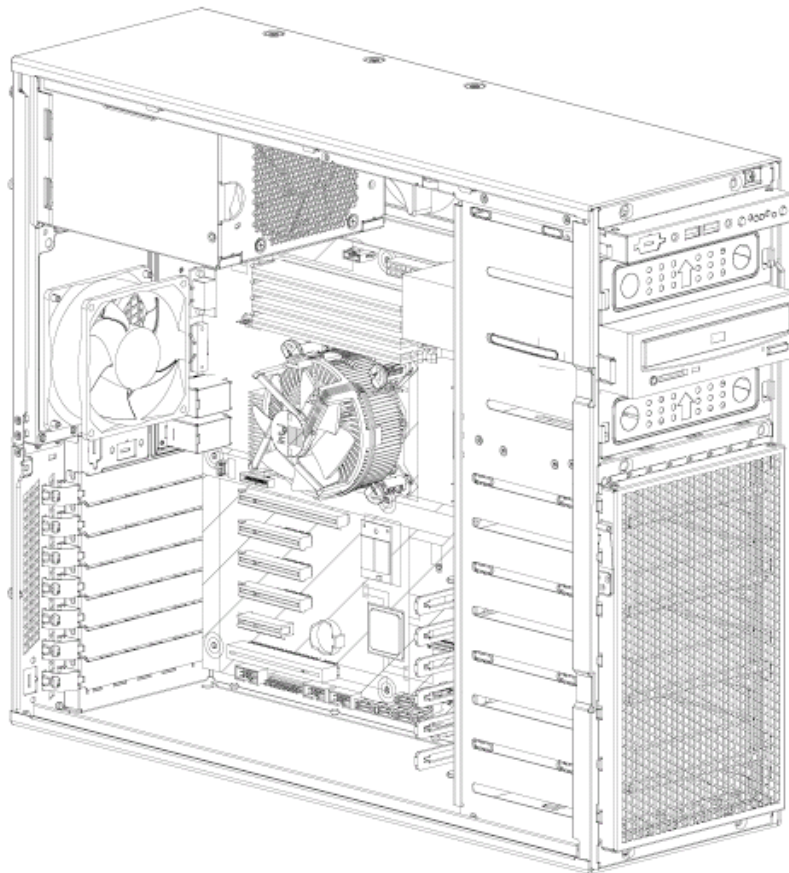

Figure 37. Active Heat Sink and Chassis Rear Fan in Intel® Server Chassis P4304XXSFCN

The power supply fan assists in drawing air through the peripheral bay area, through the power supply and exhausting it out the rear of the chassis.

Refer to the baseboard documentation for additional details on thermal and configuration requirements.

3.2 Cooling solution for Intel® Server Board S2400SC

Two 92 x 32 mm fans provide cooling for the processors, memory, hard drives and add-in cards. The two fans draw air through the rear of each hard drive bay to provide drive, processors, and memory cooling. All system fans provide a signal for RPM detection the server board can make available for server management functions. In addition, the power supply fan provides cooling for the power supply.

The default location of the two system fans is shown below:

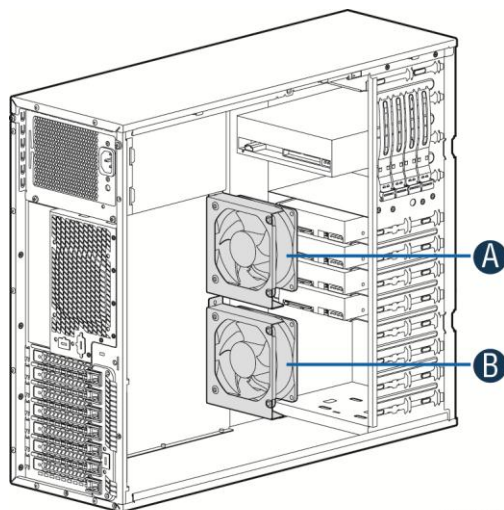

AF005492

- A. CPU zone system fan
- B. PCI zone system fan

Figure 38. Chassis System Fans Default location in Intel® Server Chassis P4304XXSFEN

To support full height full length PCI card, the PCI zone system fan in above figure can be reinstalled as shown below:

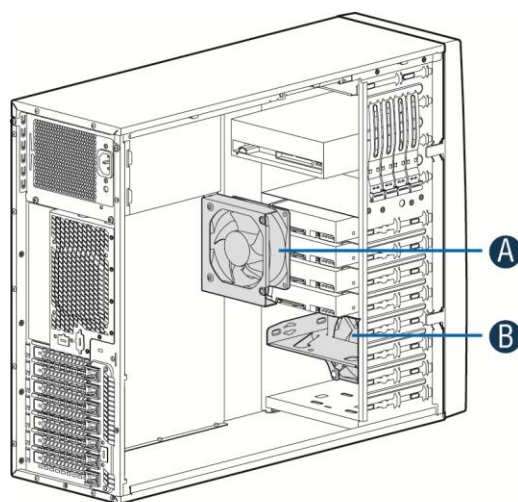

AF005493

Figure 39. Chassis System Fans to support full length card in Intel® Server Chassis P4304XXSFEN

The Air duct for Intel® Server Board S2400SC must be installed to keep the system operating within supported maximum thermal limits.

Refer to the baseboard documentation for additional details on thermal and configuration requirements.

3.3 Fan Control

The fans provided in the Intel® Server Chassis P4000S Family contains a tachometer signal that can be monitored by the server management subsystem of the Intel® Server Boards for RPM (Revolutions per Minute) detection.

The server board monitors several temperature sensors and adjusts the PWM (Pulse Width Modulated) signal to drive the fan at the appropriate speed.

The front panel of the chassis has a digital temperature sensor connected to the server board through the front panel's bus. The server board firmware adjusts the fan speed based on the front panel intake temperature and processor temperatures.

Refer to the baseboard documentation for additional details on how fan control is implemented.

3.4 Fan Header Connector Descriptions

All system fan headers support pulse width modulated (PWM) fans for cooling the processors in the chassis. PWM fans have an improved RPM range (20% to 100% rated fan speed) when compared to voltage controlled fans.

The fixed chassis fans are a 4-wire/4-pin style designed to plug into 4-pin or 6-pin SSI Fan headers. When plugged into a 6-pin header, only the first four signals are used (Pwr, Gnd, Tach, PWM).

4. Standard Front Panel

4.1 Front Panel Overview

The Front Panel will be used for Intel® Server Board S1200BTL, S1200BTS and other platforms. It is a common front panel across different sever boards and systems.

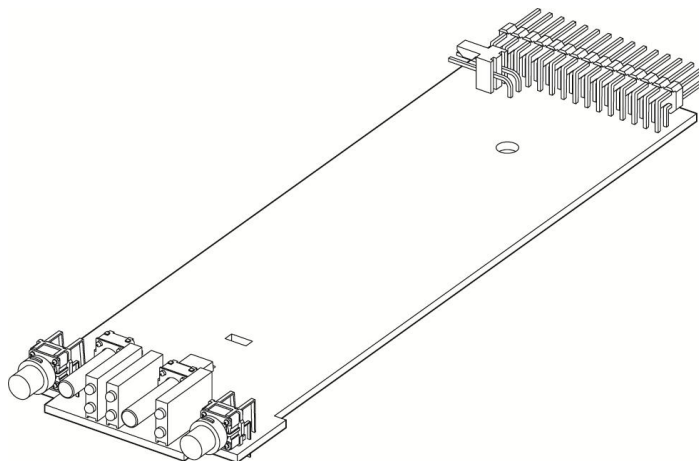

AF003625

Figure 40. Front Panel overview

This front panel conforms to SSI specification with one exception that up to 4 LAN act/link LEDs are supported. The common front panel can support either the standard SSI 2x12 cable interconnect (2 LAN ports) or an EPSD customized 2x15 cable interconnect (4 LAN ports). With Intel® Server Board S1200BT, the front panel supports standard SSI specification by using the standard SSI 2X 12 cables

4.2 Front Panel Features

The Front panel has the following features:

- Power button with integrated power LED (green).
- Chassis ID button with integrated ID LED (blue).
- Status/Fault LED (green/amber) (Conform to the BT board).
- Reset button.
- Global HDD activity LED (One HDD action).
- 4 LAN activity/link LEDs (Intel® Server Board S1200BT is using 2 LAN LEDs, such as NIC_1_LED and NIC_2_LED).
- NMI button
- Connectors: RA 2x15pin signal connector (supports 2x12pin SSI FP connections) and SSI 1x2pin chassis intrusion.

4.3 Common Front Panel Placement

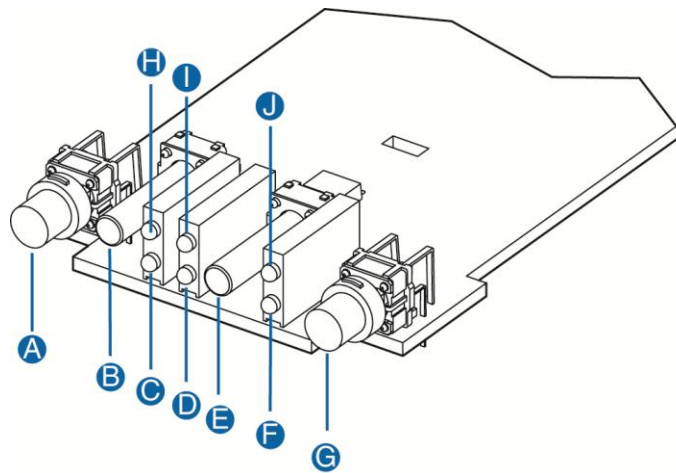

AF003626

Description		Description	
A	Unstuffable ID Button with ID LED	F	Status/Fault LED
B	NMI Button	G	Power Button with power LED
C	LAN1 LED	H	LAN2 LED
D	LAN3 LED	I	LAN4 LED
E	Reset Button	J	HDD activity LED

Figure 41. Common Front Panel LED/Button Arrangement

4.3.1 Common Front Panel LED Functionality

Table 94. Front Panel LED Functionality

LED	Color	Condition	What It Means
Power/Sleep	Green	On	Power on or S0 sleep.
	Green	Blink	S1 sleep or S3 standby only for workstation baseboards.
		Off	Off (also sleep S4/S5 modes).
Status	Green	On	System ready/No alarm.
	Green	Blink	System ready, but degraded: redundancy lost such as PS or fan failure; non-critical temp/voltage threshold; battery failure; or predictive PS failure.
	Amber	On	Critical alarm: Voltage, thermal, or power fault; CPU missing; insufficient power unit redundancy resource offset asserted.
	Amber	Blink	Non-Critical failure: Critical temp/voltage threshold; VDR hot asserted; min number fans not present or failed.
		Off	AC power off: System unplugged. AC power on: System powered off and in standby, no prior degraded/non-critical/critical state.
Global HDD Activity	Green	Blink	HDD access.
		Off	No access and no fault.
LAN 1-4	Green	On	LAN link/no access.

LED	Color	Condition	What It Means
Activity/Link (LAN 1-2 for Intel® Server Board S1200BT)	Green	Blink	LAN access.
		Off	Idle.
Chassis Identification	Blue	On	Front panel chassis ID button pressed.
	Blue	Blink	Unit selected for identification from the software.
		Off	No identification.

Note: This is dependent on server board support. Not all server boards support all features. For additional details about control panel functions supported for a specific board, refer to the individual server board specifications.

4.4 Common Front Panel Connector List and Pinouts

Below is a list of the connectors needed for this board.

Table 95. Connectors for Boards

Function	Qty
RA 2x15 FP	1
RA 1x2 Chassis Intrusion	1

4.4.1 Pinouts

The following table describes the pinouts:

Table 96. Pinouts Signal Description

Pin	Signal Description	Pin	Signal Description
1	Power LED Anode	2	Front Plane Power (P3V3_STBY)
3	Key Pin	4	System ID LED Anode
5	Power LED Cathode	6	System ID LED Cathode
7	HDD Activity LED Anode	8	System status LED1 Cathode (Green)
9	HDD Activity LED Cathode	10	System status LED2 Cathode (Amber)
11	Power Switch	12	NIC_1 Activity LED Anode
13	Power Switch (GND)	14	NIC_1 Activity LED Cathode
15	Reset Switch	16	SMBus SDA
17	Reset Switch (GND)	18	SMBus SCL
19	System ID Switch	20	Chassis Intrusion
21	1-wire Temp Sensor (unused)	22	NIC_2 Activity LED Anode
23	NMI to CPU Switch	24	NIC_2 Activity LED Cathode
25	Key Pin	26	Key Pin
27	NIC_3 Activity LED Anode	28	NIC_4 Activity LED Anode
29	NIC_3 Activity LED Cathode	30	NIC_4 Activity LED Cathode

Note: Pin 1~24 is compatible with SSI spec.

Table 97. Chassis Intrusion Pin-out

	Description
	RA 1x2 Chassis Intrusion
Pin	Signal Description
1	FP_CHASSIS_INTRU
2	GND

5. 4x3.5" Hot-Swap Back Plane (HSBP)

5.1 Overview

The Chassis supports 4x3.5" SAS/SATA backplane. The backplane provides the platform support for up to four hot-swap SAS or SATA hard drives.

5.1.1 Key Features

The 4HDD SAS/SATA HSBP supports the following feature set:

- 4x SAS/SATA 3.5" hot swap hard drive at 6Gb SAS/SATA or slower speeds.
- One SGPIO SFF-8485 interface from a 5pin connector.
- One I2C interface from a 5pin connector for HDD status communication to BMC over slave SMB bus.
- Temperature sensor and FRU support.
- In-application FW updateable over I2C interfaces from the BMC. No special hardware needed for field FW upgrade with BMC onboard EPSD baseboard.
- 4 HDD status LEDs and 4 HDD activity LEDs.
- 4 HDD presence detect inputs to the microcontroller.
- 3.3V linear regulator for to power microcontroller and various other components.
- Four 7 pin shrouded latching THMT SAS/SATA input connectors.
- 29pin SAS/SATA 'hybrid' docking hotswap connectors.

5.1.2 Board Layout

The following figure shows the board layout and connectors placement of the 4HDD SAS/SATA hot-swap backplane.

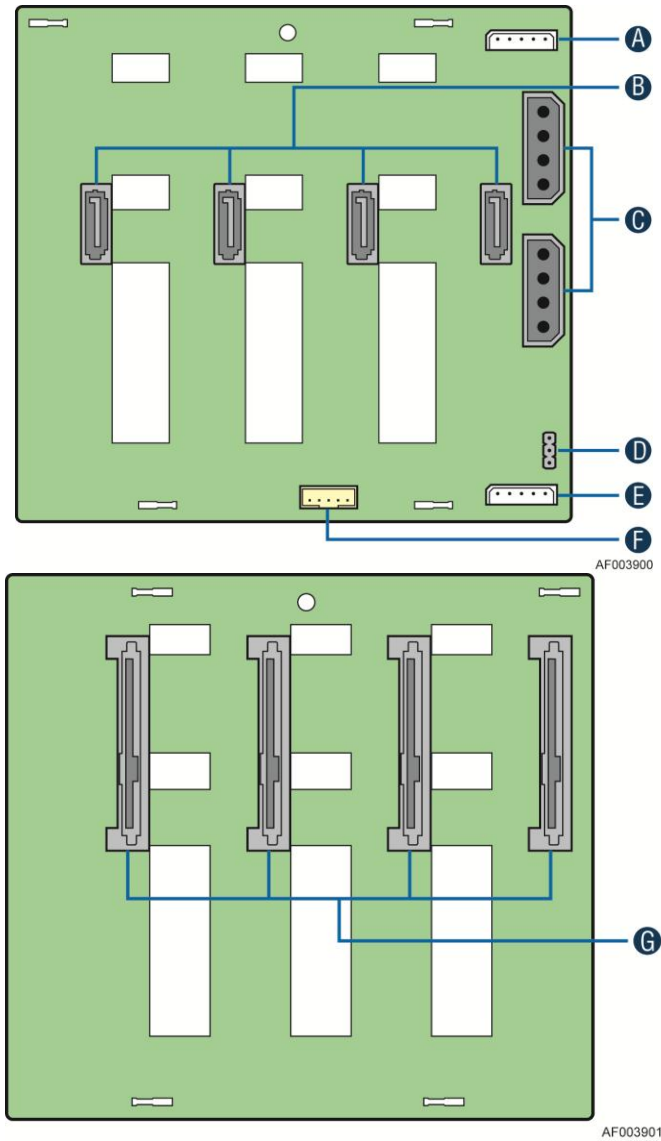

- A. I2C_In Connectors
- B. SATA/SAS Cable Connctors
- C. Power Connectors
- D. SATA 6X Mode
- E. I2C_Out Connectors
- F. SGPIO connector
- G. SATA/SAS Hot-swap Drive Connectors

Figure 42. 4x3.5" HSBP Board Layout

Note: Secondary side is mirrored.

5.2 4x 3.5" HSBP Functional Description

5.2.1 4x3.5" HSBP Microcontroller

The microcontroller Cypress PSoC (CY8C22545-24AXI) is sized for 4x and 8x HSBP. It includes I2C interface hardware for in application updating of FW operational code from the I2C interface.

Following are the microcontroller signal names and pin numbers:

Table 98. 4x3.5" HSBP Microcontroller Pinouts

Pin	Pin Name	Signal Name
1	P2[5]	FM_HDD_PRSENT1
2	P2[3]	SGPIO_DATAOUT_0
3	P2[1]	SGPIO_DATAIN_0
4	Vdd	P3V3
5	P4[5]	TP_SATA_6X_MODE
6	P4[3]	LED_HDD_FAULT3_N
7	P4[1]	LED_HDD_FAULT1_N
8	Vss	GND
9	P3[7]	TP_SGPIO_DATAOUT_1
10	P3[5]	TP_SGPIO_DATAIN_1
11	P3[3]	TP_HDD_PRSENT_7
12	P3[1]	TP_HDD_PRSENT_5
13	P1[7]	SMB_P3V3_CLK
14	P1[5]	SMB_P3V3_DAT
15	P1[3]	TP_P1_3
16	P1[1]	SMB_ISSP_CLK
17	Vss	GND
18	P1[0]	SMB_ISSP_DAT
19	P1[2]	TP_P1_2
20	P1[4]	SMB_ADD0
21	P1[6]	SMB_ADD1
22	P3[0]	TP_HDD_PRSENT_4
23	P3[2]	TP_HDD_PRSENT_6
24	P3[4]	TP_SGPIO_CLK_1
25	P3[6]	TP_SGPIO_LOAD_1
26	XRES	FM_ISSP_XRES
27	P4[0]	LED_HDD_FAULT0_N
28	P4[2]	LED_HDD_FAULT2_N
29	P4[4]	TP_P4_4
30	Vss	GND
31	P2[0]	SGPIO_CLOCK_0
32	P2[2]	SGPIO_LOAD_0
33	P2[4]	FM_HDD_PRSENT0
34	P2[6]	FM_HDD_PRSENT2
35	P0[0]	Therm_P0

Pin	Pin Name	Signal Name
36	P0[2]	TP_THERM_N
37	P0[4]	TP_LED_HDD_FAULT4_N
38	P0[6]	TP_LED_HDD_FAULT6_N
39	Vdd	P3V3
40	P0[7]	TP_LED_HDD_FAULT7_N
41	P0[5]	TP_LED_HDD_FAULT5_N
42	P0[3]	TP_P0_3
43	P0[1]	TP_P0_1
44	P2[7]	FM_HDD_PRSENT3

5.2.2 SGPIO Functionality

The 4x 3.5" HSBP supports a SFF-8485 compliant SGPIO interface. It is used to activate the HDD status LED as well is monitored by the microcontroller for generating fault, identify, and rebuild registers that in turn are monitored by the baseboard BMC for generating corresponding SEL events.

SGPIO uses a 5pin header; this is to incorporate a ground conductor as an SI improvement over previous generation products and based on measurement data indicating add the ground is strongly recommended. The 5pin connector will be consistent with other HSBPs, in this way cable commonality is improved.

5.2.3 I2C Functionality

The microcontroller has a master/slave I2C connection to the baseboard BMC. The microcontroller is not an IPMB compliant device. The BMC will generate SEL events by monitoring registers on the HSBP microcontroller for drive presence, fault, and RAID rebuild in progress.

I2C uses a 5pin connector; this is to add two additional address bits. This connector is keyed differently than the 5pin SGPIO connector. The 4x3.5" HSBP architecture is setup to support up to 3 HSBPs even though the 4x 3.5" HSBP is currently only indented to support up to two of them in the Intel® Server Chassis P4000S, P4000M and P4000L family. Two pins on the I2C header are used to indicate HSBP address. Below is a figure on how the addressing is recommended for up to three HSBPs.

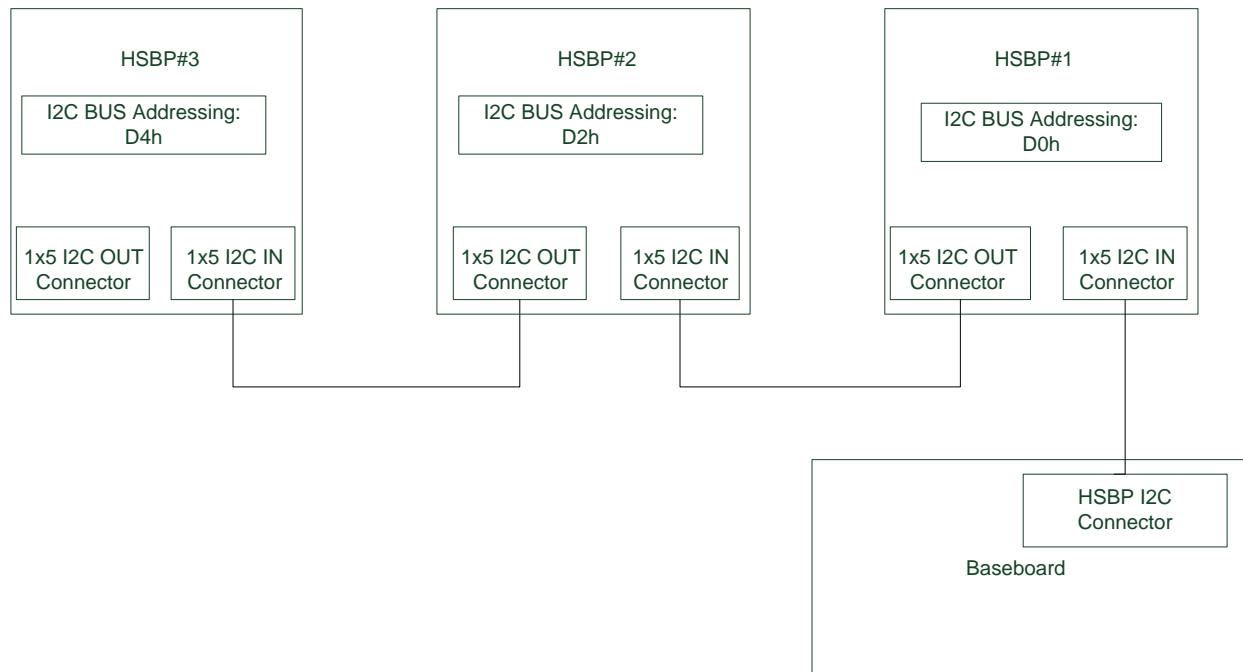

Figure 43. 4x 3.5" HSBP I2C Connectivity

5.2.4 SATA 6X Mode Jumper Functionality

The SATA 6X Mode jumper is used to enable baseboard AHCI SATA ports SGPIO function. Only when SATA 6X Mode jumper is enabled, and the SGPIO on backplane is connected to the SGPIO connector for the AHCI SATA ports on the baseboard, the AHCI SATA ports SGPIO function will be enabled.

The following table is the SATA 6X Mode Jumper Block function:

Table 99. 4x3.5" HSBP SATA 6X Mode Host Jumper Block

Function	Pins	Operation
SATA 6X Mode	1-2	Enable SATA 6x Mode
	2-3	Disable SATA 6x Mode

5.2.5 HSBP LED Functionality

Below is a table for EPSSD LED functionality for HSBP board.

Table 100. Romley LED Functionality

HDD	Green	Blink	HDD access or spin up/down (see note below)
	Amber	On	HDD fault
	Amber	Blink	RAID rebuild in progress (1Hz), identify (2Hz)
		Off	No access and no fault

The HSBP does not route HDD activity signal to the front panel so is not subject to the LED being continuously on when running SAS HDDs. Any HDD activity (really bus activity) driven from SATA/SAS host on baseboard or HBA card hosts that cable HDD activity to baseboard 2pin header would still result in the FP LED blinking. Below is a table showing HDD activity LED differences between with SATA and SAS HDDs.

Table 101. HDD Activity LED Functionality

Condition	Drive Type	Behavior
Power On with no drive activity	SAS	Ready LED stays On.
	SATA	Ready LED stays Off.
Power On with drive activity	SAS	Ready LED blinks Off when processing a command.
	SATA	Ready LED blinks On when processing a command.
Power On and drive spun down	SAS	Ready LED stays Off.
	SATA	Ready LED stays Off.
Power On and drive spun down	SAS	Ready LED blinks*.
	SATA	Ready LED stays Off.

HSBP does not need to route HDD fault LED function to front panel fan board. This function is already lumped with system fault LED already on the FP.

5.3 4x3.5" HSBP Connector List and Pinouts

Below is a list of the connectors needed for this board.

Table 102. 4x3.5" HSBP Connector List

Function	Color	Qty
29Pin Hot Swap Docking Connector	Black	4
7Pin Input SAS/SATA Connector	Black	4
1x4Pin Power Connector	White	2
1x5Pin I2C Connector (In)	White	1
1x5Pin I2C Connector (Out)	Blue	1
1x5Pin SGPIO Connector	White	1

5.3.1 Pinouts

Table 103. 4x3.5" HSBP SGPIO Connector Pinouts

	Description
-	1x5pin SATA SGPIO
Pin	Signal Description
1	SGPIO_CLOCK_0
2	SGPIO_LOAD_0
3	GND
4	SGPIO_DATAOUT_0
5	SGPIO_DATAIN_0

Table 104. 4x3.5" HSBP I2C(In) Connector Pinouts

	Description
-	1x5Pin I2C Connector (In)
Pin	Signal Description
1	SMB_3V3SB_DAT
2	GND
3	SMB_3V3SB_CLK
4	SMB_ADD0
5	SMB_ADD1

Table 105. 4x3.5" HSBP I2C (Out) Connector List

	Description
-	1x5Pin I2C Connector (Out)
Pin	Signal Description
1	SMB_3V3SB_DAT
2	GND
3	SMB_3V3SB_CLK
4	SMB_ADD0
5	SMB_ADD1

Table 106. 4x3.5" HSBP Power Connector Pinouts

	Description
	1x4Pin Power Connector
Pin	Signal Description
1	P12V
2	GND
3	GND
4	P5V

Note: See SAS/SATA specs for pinout of 29pin and 7pin connectors.

5.4 4x3.5" HSBP Cabling Requirements

The 4x 3.5" HSBP requires the following cables:

1. Ganged 4x SATA/SAS data cable.
2. I2C cable - 5pin on HSBP side to 3pin on baseboard side
3. SGPIO cable - 5pin on HSBP side to 5pin on host controller side.

6. System Interconnection

6.1 Chassis Internal Cables

Note: This chapter provides the chassis internal cables specification descriptions. Different chassis configuration may come with different cable settings.

6.1.1 Front Panel Cable

A 24-conductor ribbon cable with 24-pin IDC connectors links the front panel to the SSI EEB Revision 3.61-compliant server board.

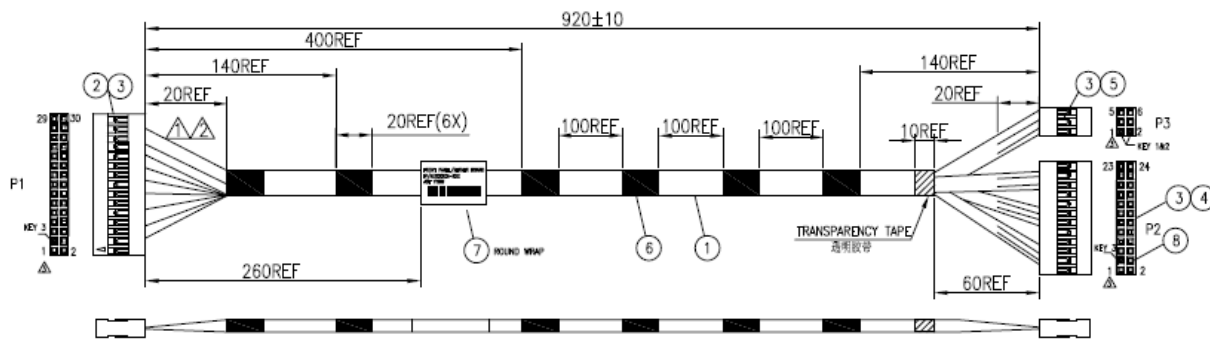

Figure 44. Chassis Front Panel Cable

6.1.2 Intrusion Switch cable

The intrusion switch cable acts as a switch installed on the chassis for chassis intrusion detection, allowing server management software to detect unauthorized access to the system side cover. The cable is connected to the front panel through a 2-pin chassis intrusion header on the front panel board.

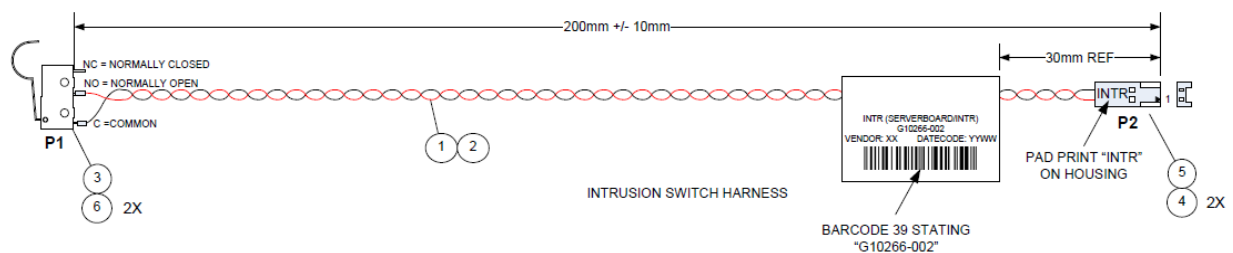

Figure 45. Intrusion Switch Cable

6.1.3 USB Cable

A 10-conductor USB cable with 10-pin connectors at one end and two 4-pin external USB connectors at the other end is used for connecting the front panel-mounted USB connector to the server board.

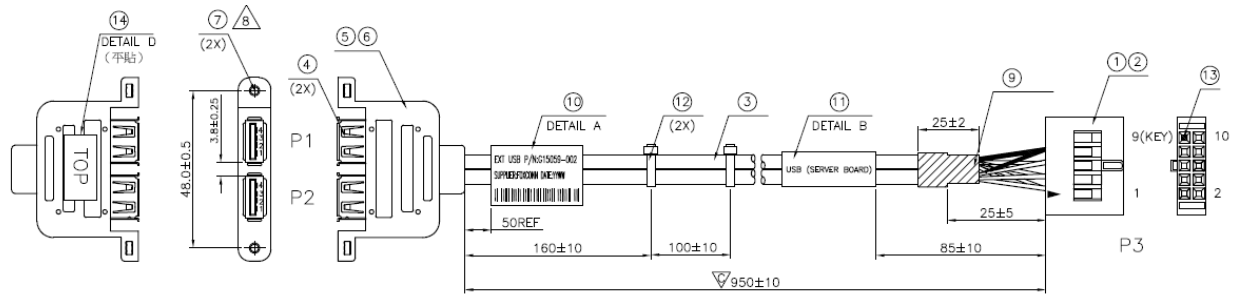

Figure 46. USB Cable Drawing

6.1.4 SATA Power Adapter Cable

The SATA Power Adapter Cable has a 4-pin LP4 connector at one end, two 15-pins SATA power connector at the other end. The cable is used for connecting the SATA Hard Drive to a standard 4-pin LP4 power connector.

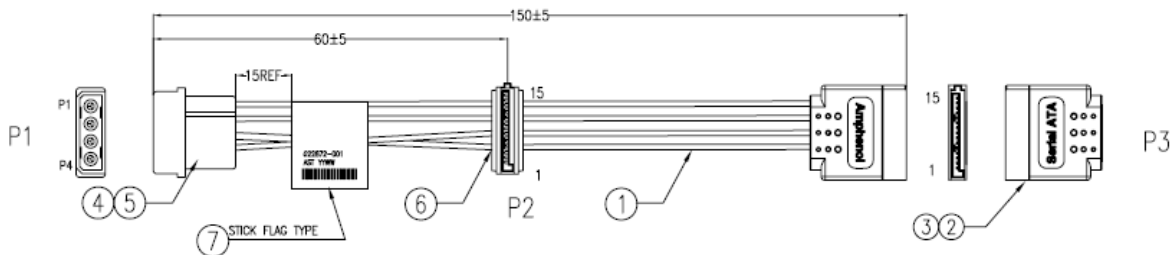

Figure 47. SATA Power Adapter Cable

6.1.5 SATA cable for HDDs/ODD

The SATA cables with two 7-pin SATA connectors are used for connecting the SATA HDDs/ODD to the server board.

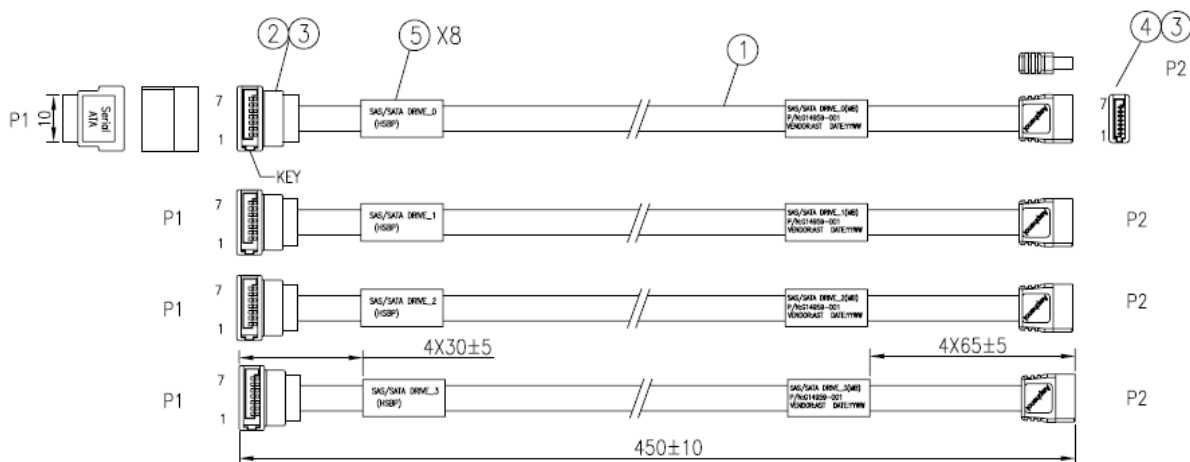

Figure 48. SATA cable for HDDs (450mm)

6.1.6 Mini SAS(MB) to 4pcs 7Pin SATA Cable with SGPIO Cable

The cable has a 36-pin connector at one end, four 7-pin SATA connectors and a 5-pin SGPIO connector at the other end. The cable is used for connecting the motherboard Mini SAS connector to 4x3.5" HSBP SATA connectors and SGPIO connector.

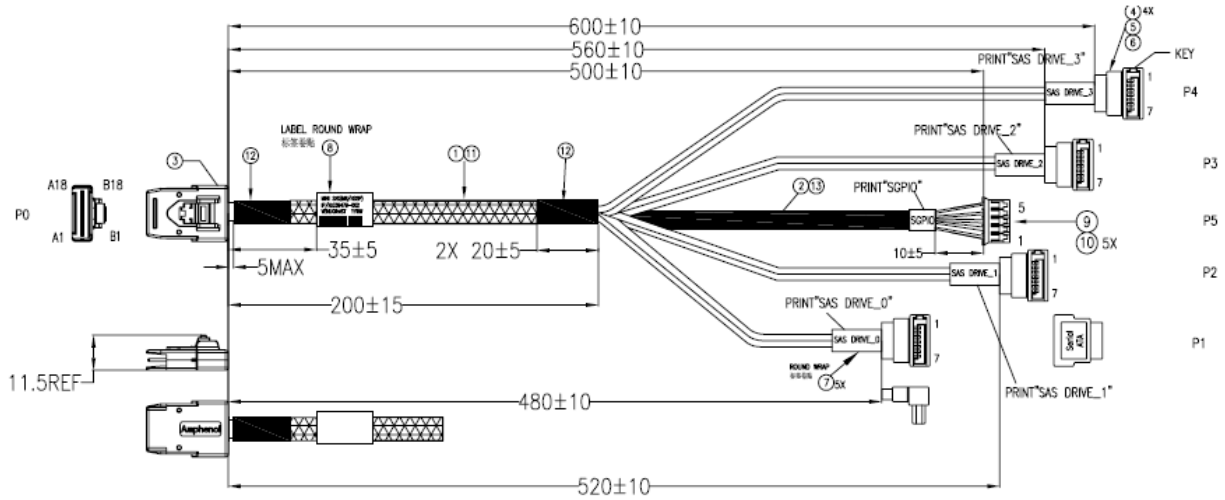

Figure 49. Mini SAS(MB) to 4pcs 7Pin SATA cable with SGPIO Cable

6.1.7 Mini SAS(MB) to 4pcs 7Pin SATA Cable

The cable has a 36-pin connector at one end, four 7-pin SATA connectors at the other end. The cable is used for connecting the motherboard Mini SAS connector to SATA connectors on fixed HDD.

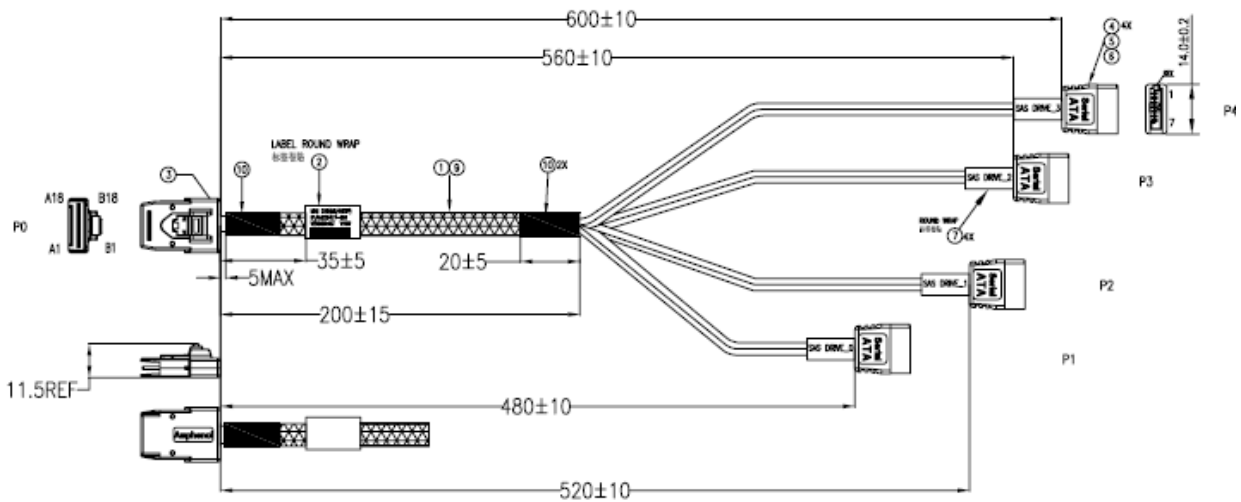

Figure 50. Mini SAS(MB) to 4pcs 7Pin SATA Cable

6.1.8 I2C Cable (5pin(HSBP)--3pin(MB))

The I2C cable is used for enclosure management communication between I/O controller (RAID) and backplane.

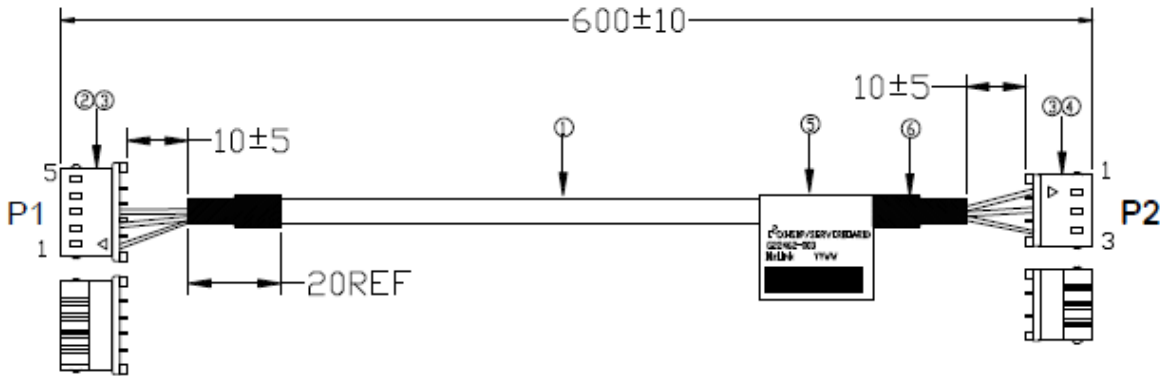

Figure 51. I2C Cable (5pin to 3pin)

6.1.9 SGPIO Cable

The SGPIO cable acts as an enclosure management interface between ESB2 and the backplane and is used by SW RAID to provide basic array device status indication from the visual LEDs.

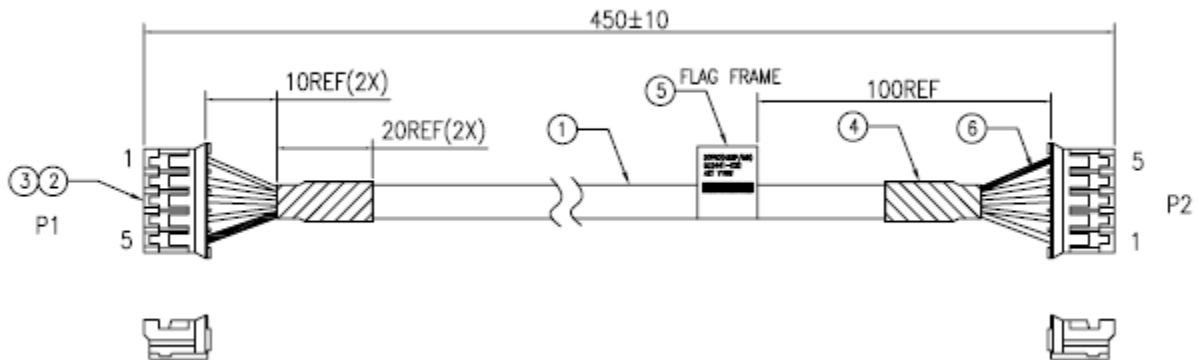

Figure 52. SGPIO Cable

7. System-Compatible Intel® Server Boards

The Intel® Server Chassis P4000S family supports the following Intel® server boards:

Table 107. System-Compatible Intel® Server Boards

	Intel® Server Chassis P4304XXSFCN	Intel® Server Chassis P4304XXSHCN	Intel® Server Chassis P4304XXSFEN P4304XXSHEN P4304XXSFDR P4304XXSHDR P4304XXSFDN P4304XXSHDN
Intel® Server Board Support	<ul style="list-style-type: none"> • S1200BTL • S1200BTS 	S1200BTL	S2400SC

8. Reliability, Serviceability, and Availability

8.1 Mean Time between Failure

The following is the calculated Mean Time Between Failures (MTBF) at maximum configuration at 40°C (ambient air). These values are derived using a historical failure rate and multiplied by factors for application, electrical and/or thermal stress and for device maturity. MTBF estimates should be viewed as “reference numbers” only.

- Telcordia SR_332 Issue II: Reliability Prediction Procedure
- Method 1: Parts Count Prediction
- Case III: Generic Value + Quality + Stress + Temperature
- Confidence Level: 90%
- Quality Level: II
- Temperature: Customer Specified (default 40°C)
- Duty Cycle: Continuous, 100%
- Operating Environment: Ground Benign, Fixed, Controlled

Table 108. Calculated Mean Time Between Failure – P4304XXSFCN and P4304XXSHCN

Subassembly (Server in 40°C ambient air)	Intel® Server Chassis P4304XXSFCN		Intel® Server Chassis P4304XXSHCN	
	MTBF (Hours)	FIT (Failures/10 ⁹ hrs)	MTBF (Hours)	FIT (Failures/10 ⁹ hrs)
S1200BTL Baseboard	172,199	5,807	172,199	5,807
Power Supply (365 W Non Redundant)	619,607	1,614	619,607	1,614
Cooling fans (Non- redundant)	206,885	4,834	206,885	4,834
Backplane board – 4x3.5"	NA	NA	935,180	1,069
Front Panel board	8,272,282	121	8,272,282	121
Totals with motherboard=	80800	12,376	74300	13,445
Totals with motherboard	152200	6,568	130900	7,638

Table 109. Calculated Mean Time Between Failure – P4304XXSFEN and P4304XXSHEN

Subassembly (Server in 40°C ambient air)	Intel® Server Chassis P4304XXSFEN		Intel® Server Chassis P4304XXSHEN	
	MTBF	FIT	MTBF	FIT
	(Hours)	(Failures/10 ⁹ hrs)	(Hours)	(Failures/10 ⁹ hrs)
S2400SC Baseboard	168,035	5,951	168,035	5,951
Power Supply (550 W Non Redundant)	474,910	2,106	474,910	2,106
Cooling fans (Non- redundant)	196,687	5,084	196,687	5,084
Backplane board - 4x3.5"	NA	NA	935,180	1,069
Front Panel board	8,272,282	121	8,272,282	121
Totals with motherboard=	136700	7,311	119300	8,380
Totals with motherboard	75400	13,262	69700	14,331

Table 110. Calculated Mean Time Between Failure – P4304XXSFDR and P4304XXSHDR

Subassembly (Server in 40°C ambient air)	Intel® Server Chassis P4304XXSFDR		Intel® Server Chassis P4304XXSHDR	
	MTBF	FIT	MTBF	FIT
	(Hours)	(Failures/10 ⁹ hrs)	(Hours)	(Failures/10 ⁹ hrs)
S2400SC Baseboard	168,035	5,951	168,035	5,951
Power Supply (Two 460 W Redundant)	1,186,122	843	1,186,122	843
Low Current PDB Board	1,726,969	579	1,726,969	579
Cooling fans (Non- redundant)	196,687	5,084	196,687	5,084
Backplane board - 4x3.5"	NA	NA	935,180	1,069
Front Panel board	8,272,282	121	8,272,282	121
Totals with motherboard=	150800	6,627	129900	7,697
Totals with motherboard	79500	12,578	73200	13,648

Table 111. Calculated Mean Time Between Failure – P4304XXSFDN and P4304XXSHDN

Subassembly (Server in 40°C ambient air)	Intel® Server Chassis P4304XXSFDN		Intel® Server Chassis P4304XXSHDN	
	MTBF (Hours)	FIT (Failures/10 ⁹ hrs)	MTBF (Hours)	FIT (Failures/10 ⁹ hrs)
S2400SC Baseboard	168,035	5,951	168,035	5,951
Power Supply (One 460 W)	790,748	1,265	790,748	1,265
Low Current PDB Board	1,726,969	579	1,726,969	579
Cooling fans (Non- redundant)	196,687	5,084	196,687	5,084
Backplane board - 4x3.5"	NA	NA	935,180	1,069
Front Panel board	8,272,282	121	8,272,282	121
Totals with motherboard=	141800	7,049	123100	8,118
Totals with motherboard	76900	13,000	71000	14,069

8.2 Serviceability

The system is designed for service by qualified technical personnel only. The desired Mean Time to Repair (MTTR) of the system is 30 minutes including the diagnosis of the system problem. To meet this goal, the system enclosure and hardware were designed to minimize the mean time to repair. The following are the maximum times a trained field service technician should take to perform the listed system maintenance procedures after diagnosis of the system.

Table 112. Maximum Maintenance Procedure Times

Activity	Time Estimate
Remove cover	< 1 minute
Remove and replace fixed hard disk drive	<3 minutes
Remove and replace hot-swap hard disk drive	<2 minute
Remove and replace 5.25-inch peripheral device	< 1 minutes
Remove and replace fixed power supply module	<5 minutes
Remove and replcae hot-swap power supply module	15 second
Remove and replace hot-swap power supply cage	<5 minutes
Remove and replace fixed fan	<2 minute
Remove and replace expansion board (PCI Adaptor Card)	<2 minutes
Remove and replace backplane board	<5 minutes
Remove and replace front panel board	<3 minutes
Remove and replace server board (with no expansion boards)	<7 minutes
Overall Mean Time To Repair (MTTR)	<30 minutes

9. Environmental Limits

9.1 System Office Environment

Table 113. System Office Environment Summary

Parameter	Limits
Operating temperature	+10°C to +35°C with the maximum rate of change not to exceed 10°C per hour.
Non-operating temperature	-40°C to +70°C
Non-operating humidity	50% to 90%, non-condensing with a maximum wet bulb of 28° C (at temperatures from 25° C to 35° C)
Acoustic noise	7.0 BA LWA in a typical office ambient temperature (18-25°C)
Shock Operating	Half sine, 2 g, 11 milliseconds
Shock Unpackaged	Trapezoidal, 25 g, velocity change 136 inches/second (≥ 40 lbs to < 80 lbs)
Shock Packaged	Operational after a free fall of 9 – 36-inches depending on the weight
Vibration unpackaged	5 Hz to 500 Hz 2.20 g RMS random
Vibration packaged	5 Hz to 500 Hz 1.09 g RMS random
Packaged shock	Operational after a free fall of 9 – 36-inches depending on the weight
ESD	Air discharge: 0 to 15.0kV; Contact Discharge: 0 to 8.0kV

9.2 System Environmental Testing

The system will be tested per the Environmental Standards Handbook, Intel Doc 25-GS0009. These tests shall include:

- Acoustic Sound Power
- Temperature operating and non-operating
- Humidity non-operating
- Shock Operating, Shock Packaged and Shock unpackaged
- Vibration Packaged and Vibration Unpackaged
- AC, DC, and I/O Surge
- AC voltage, frequency, and source interrupt
- Conducted Immunity
- DC Voltage and Source Interrupt
- Electrical Fast Transient (EFT)
- Electrostatic discharge (ESD)
- Flicker and Voltage Fluctuation
- Power Frequency Magnetic Fields
- Power Line Harmonics
- Radiated Emissions
- Radiated Immunity

- Telecom Power Line Conducted Emissions
- Voltage Dip and Dropout
- Reliability Test

9.3 Intel® Server Chassis P4000S Family Acoustic Level

The following tables detail the declared acoustic data for reference.

9.3.1 Intel® Server Chassis P4000S Family with Intel® Server Board S1200BTL

9.3.1.1 Test Conditions at Acoustic Lab

Table 114. Test Conditions at Acoustic Lab

Function	Conditions/Stress Software
Idle Mode	Windows*-2k8R2 Idling
Stress Mode_TO1	IO meter + PTU_1.5 (Core 50%)
Stress Mode_TO2	IO meter + memBW4 Delay 1

9.3.1.2 Test Environment

The room temperature shall be 23°C+/-2°C, recommend related humidity is 40% ~70% based on ISO-7779 standard.

9.3.1.3 Declared Acoustic Data

Table 115. System Configurations

	Configuration 1	Configuration 2
Chassis	P4304XXSFCN	P4304XXSHCN
Motherboard	S1200BTL	S1200BTL
CPU TDP	95W	95W
Memory	4GB UDIMM fully populated	4GB UDIMM fully populated
PCI card	5 PCI cards each with 15W	5 PCI cards each with 15W
HDD	4 SAS HDDs populated	4 SAS populated
Stress mode	Idle Mode/TO1/TO2	Idle Mode/TO1/TO2

Table 116. Declared Acoustic Data of Intel® Server Chassis P4000S family with Intel® Server Board S1200BTL

Conditions	Declared A-weighted Sound Power Level per ISO9296, LwAd (BA)	
	Configuration 1	Configuration 2
Idle Mode	3.80	5.1
Stress Mode_TO1	3.88	5.2
Stress Mode_TO2	4.0	5.1

9.3.2 Intel® Server Chassis P4000S Family with Intel® Server Board S1200BTS

9.3.2.1 Test Conditions at Acoustic Lab

Table 117. Test Conditions at Acoustic Lab

Function	Conditions/Stress Software
Idle Mode	Windows*-2k8R2 Idling
Stress Mode_TO1	IO meter + PTU_1.5 (Core 50%)
Stress Mode_TO2	IO meter + memBW4 Delay 1

9.3.2.2 Test Environment

The room temperature shall be 23°C+/-2°C, recommend related humidity is 40% ~70% based on ISO-7779 standard.

9.3.2.3 Declared Acoustic Data

Table 118. System Configurations

	Configuration 1
Chassis	P4304XXSFCN
Motherboard	S1200BTS
CPU TDP	95W
Memory	4GB UDIMM fully populated
PCI card	4 PCI cards each with 15W
HDD	4 SATA HDDs populated
Stress mode	Idle Mode/TO1/TO2

Table 119. Declared Acoustic Data of Intel® Server Chassis P4000S family with Intel® Server Board S1200BTS

Conditions	Declared A-weighted Sound Power Level per ISO9296, LwAd (BA)
	Configuration 1
Idle Mode	4.5
Stress Mode_TO1	4.8
Stress Mode_TO2	4.7

9.3.3 Intel® Server Chassis P4000S Family with Intel® Server Board S2400SC

9.3.3.1 Test Conditions at Acoustic Lab

Table 120. Test Conditions at Acoustic Lab

Function	Conditions/Stress Software
Idle Mode	OS Idling
Stress Mode_TO	IO meter + PTU_1.5 (Core and Memory 50%)

9.3.3.2 Test Environment

The room temperature shall be 23°C+/-2°C, recommend related humidity is 40% ~70% based on ISO-7779 standard.

9.3.3.3 Declared Acoustic Data

Table 121. System Configurations

	Configuration 1	Configuration 2
Chassis	P4304XXSHEN	P4304XXSHDR
Motherboard	S2400SC	S2400SC
CPU TDP	95W	95W
Memory	R/C DRX8 fully populated	R/C DRX8 fully populated
GPGPU/card	3 PCI cards	3 PCI Cards
HDD	2 HDDs populated	2 HDDs populated
Stress mode	Idle Mode/TO	Idle Mode/TO

Table 122. Declared Acoustic Data of Intel® Server Chassis P4000S family with Intel® Server Board S2600SC

Conditions	Declared A-weighted Sound Power Level per ISO9296, LwAd (BA)			
	Configuration 1		Configuration 2	
	System fans in default position (Refer to Figure 38)	System fans is reinstalled for full length PCI cards (Refer to Figure 39)	System fans in default position (Refer to Figure 38)	System fans is reinstalled for full length PCI cards (Refer to Figure 39)
Idle Mode	5.3	5.5	5.3	5.5
Stress Mode_TO	5.5	5.7	5.5	5.7

10. Product Regulatory Compliance

Please refer to the Server Products Regulatory and Safety document for the product regulatory compliance reference. The document can be downloaded from <http://www.intel.com/support/motherboards/server/>.

Appendix A: Integration and Usage Tips

This appendix provides a list of useful information that is unique to the Intel® Server Chassis P4000S family and should be kept in mind while integrating and configuring your server.

System fans are not hot swappable.

The Intel® Local Control Panel can only be used with systems configured with an Intel® Management Module.

Make sure the latest system software is loaded on the server. This includes system BIOS, FRU/SDR, BMC firmware, and hot-swap controller firmware. The latest system software can be downloaded from <http://www.intel.com/support/motherboards/server/>.

Glossary

Word/Acronym	Definition
ACA	Australian Communication Authority
ANSI	American National Standards Institute
ATA	Advanced Technology Attachment
ATX	Advanced Technology Extended
Auto-Ranging	Power supply that automatically senses and adjust itself to the proper input voltage range (110 VAC or 220 VAC). No manual switches or manual adjustments are needed.
BMC	Baseboard Management Controller
CFM	Cubic Feet per Minute (airflow)
CMOS	Complementary Metal Oxide Silicon
Dropout	A condition that allows the line voltage input to the power supply to drop to below the minimum operating voltage.
EEB	Entry-level Electronics Bay
EM	Expander Management
EMC	Electromagnetic compatibility,
EMI	Electromagnetic Interference
EMP	Emergency Management Port
ESD	Electrostatic Discharge
FIT	Failures In Time
FP	Front Panel
FRB	Fault Resilient Booting
FRU	Field Replaceable Unit
GPIO	General Purpose Input and Output
HSBP	Hot-swap Backplane
I/O	Input/Output
I2C	Inter-Integrated Circuit
IPMB	Intelligent Platform Management Bus
IPMI	Intelligent Platform Management Interface
Latch Off	A power supply, after detecting a fault condition, shuts itself off. Even if the fault condition disappears, the supply does not restart unless manual or electronic intervention occurs. Manual intervention commonly includes briefly removing and then reconnecting the supply, or using a switch. Electronic intervention can be completed by electronic signals in the Server System.
LCD	Liquid Crystal Display
LCP	Local Control Panel
LPC	Low-Pin Count
LQFP	Lower Profile Quad Flat Pack
Monotonically	A waveform changes from one level to another in a steady fashion, without intermediate retrenchment or oscillation.
MTBF	Mean Time Between Failure
MTTR	Mean Time to Repair
Noise	The periodic or random signals over frequency band of 10 Hz to 20 MHz.
OCP	Over Current Protection

Word/Acronym	Definition
OTP	Over Temperature Protection
Over-current	A condition in which a supply attempts to provide more output current than the amount for which it is rated. This commonly occurs if there is a 'short circuit' condition in the load attached to the supply.
OVP	Over Voltage Protection
PDB	Power Distribution Board
PFC	Power Factor Correction
PMBus*	Power Management Bus
PSU	Power Supply Unit
PWM	Pulse Width Modulate
ppm	Parts per million
PWOK	A typical logic level output signal provided by the supply that signals the Server System that all DC output voltages are within their specified range
RI	Ring Indicate
Ripple	The periodic or random signals over frequency band of 10 Hz to 20 MHz.
Rise Time	The time it takes any output voltage to rise from 10% to 95% of its nominal voltage.
Sag	The condition where the AC line voltage drops below the nominal voltage conditions
SAS	Serial Attached SCSI
SATA	Serial ATA
SCA	Single Connector Attachment
SCSI	Small Computer System Interface
SDK	Software Development Kit
SDR	Sensor Data Record
SE	Single-Ended
SES	SCSI Enclosure Service
SGPIO	Serial General Purpose Input/Output
SMBUS	System Management Bus
SSI	Server System Infrastructure
Surge	AC line voltage rises above nominal voltage
TACH	Tachometer
THD	Total Harmonic Distortion
UART	Universal Asynchronous Receiver Transmitter
USB	Universal Serial Bus
VCCI	Voluntary Control Council for Interference
VSB or Stand By	An output voltage that is present whenever AC power is applied to the AC inputs of the supply.