



Intel[®] Server System P4000IP and Intel[®] Workstation System P4000CR Family

Technical Product Specification

Intel reference number G38159-001



Revision 1.0

February, 2012

Enterprise Platforms and Services Marketing

Revision History

Date	Revision Number	Modifications
February, 2012	1.0	Initial release.

Disclaimers

Information in this document is provided in connection with Intel® products. No license, express or implied, by estoppel or otherwise, to any intellectual property rights is granted by this document. Except as provided in Intel®'s Terms and Conditions of Sale for such products, Intel® assumes no liability whatsoever, and Intel disclaims any express or implied warranty, relating to sale and/or use of Intel products including liability or warranties relating to fitness for a particular purpose, merchantability, or infringement of any patent, copyright or other intellectual property right. Intel products are not intended for use in medical, life saving, or life sustaining applications. Intel may make changes to specifications and product descriptions at any time, without notice.

Designers must not rely on the absence or characteristics of any features or instructions marked “reserved” or “undefined”. Intel reserves these for future definition and shall have no responsibility whatsoever for conflicts or incompatibilities arising from future changes to them.

This document contains information on products in the design phase of development. Do not finalize a design with this information. Revised information will be published when the product is available. Verify with your local sales office that you have the latest datasheet before finalizing a design.

The Intel® Server System P4000IP and Intel® Workstation System P4000CR Family may contain design defects or errors known as errata which may cause the product to deviate from published specifications. Current characterized errata are available on request.

Intel Corporation server baseboards contain a number of high-density VLSI and power delivery components that need adequate airflow to cool. Intel's own chassis are designed and tested to meet the intended thermal requirements of these components when the fully integrated system is used together. It is the responsibility of the system integrator that chooses not to use Intel developed server building blocks to consult vendor datasheets and operating parameters to determine the amount of air flow required for their specific application and environmental conditions. Intel Corporation cannot be held responsible if components fail or the server board does not operate correctly when used outside any of their published operating or non-operating limits.

Intel, Pentium, Itanium, and Xeon are trademarks or registered trademarks of Intel Corporation.

*Other brands and names may be claimed as the property of others.

Copyright © Intel Corporation 2012

Table of Contents

1.	Intel® Server System P4000IP and Intel® Workstation System Overview	1
1.1	Intergrated System family overview.....	1
1.1.1	Intel® Server System P4208IP4LHGC View	6
1.1.2	Intel® Server System P4216IP4LHJC View	7
1.1.3	Intel® Server System P4216IP4LHKC View.....	8
1.1.4	Intel® Server System P4224IP4LHKC View.....	9
1.1.5	Intel® Server System P4308IP4LHGC View	10
1.1.6	Intel® Server System P4308IP4LHJC(L) View	11
1.1.7	Intel® Server System P4308IP4LHKC View.....	12
1.1.8	Intel® Workstation System P4304CR2LFGN View	13
1.1.9	Intel® Workstation System P4304CR2LFJN(L) View	14
1.1.10	Intel® Workstation System P4304CR2LFKN View.....	15
1.2	Chassis dimensions	16
1.3	Front control panel feature Overview	16
1.3.1	Front Control Panel LED/Button Functionality	16
1.3.2	Front Control Panel LED Status	18
1.4	Back panel feature Overveiw	19
1.5	Hot swap Hard Drivers and front panel options	20
1.6	Chassis Security	20
1.7	Front Bezel Features.....	21
2.	System Power Sub-system.....	23
2.1	750-W Power Supply	23
2.1.1	Mechanical Overview	23
2.1.2	AC Input Requirements.....	25
2.1.3	Efficiency.....	28
2.1.4	DC Output Specification.....	28
2.1.5	Protection Circuits.....	32
2.1.6	Control and Indicator Functions.....	33
2.1.7	Thermal CLST.....	35
2.1.8	Power Supply Diagnostic “Black Box”	35
2.1.9	Firmware Uploader.....	36

2.2	1200-W Power Supply	36
2.2.1	Mechanical Overview	36
2.2.2	AC Input Requirements	39
2.2.3	Efficiency.....	41
2.2.4	DC Output Specification	41
2.2.5	Protection Circuits	45
2.2.6	Control and Indicator Functions.....	46
2.2.7	Thermal CLST.....	49
2.2.8	Power Supply Diagnostic “Black Box”	49
2.2.9	Firmware Update.....	49
2.3	1600-W Power Supply	49
2.3.1	Mechanical Overview	49
2.3.2	AC Input Requirements	52
2.3.3	Efficiency.....	54
2.3.4	DC Output Specification	55
2.3.5	Protection Circuits	59
2.3.6	Control and Indicator Functions.....	60
2.3.7	Thermal CLST.....	62
2.3.8	Power Supply Diagnostic “Black Box”	62
2.3.9	Firmware Update.....	63
2.4	Higer Current Power Common Redundant Power Distribution Board (PDB)	63
2.4.1	Mechanical Overview	64
2.4.2	DC Output Specification	65
2.4.3	Protection Circuits	75
2.4.4	PWOK (Power OK) Signal	76
2.4.5	PSON Signal	76
2.4.6	PMBus	77
3.	Thermal Management.....	78
3.1	Thermal Operation and Configuration Requirements	78
3.2	Thermal Management Overview	78
3.3	System Fan Configuration.....	78
3.3.1	Non-Redundant Cooling Solution	79
3.3.2	Redundant Cooling Solution.....	79
3.4	Fan Control	80

3.5	Fan Header Connector Descriptions	80
4.	Storage and Peripheral Drive Bays	81
4.1	2.5" Hard Disk Drive Support	81
4.1.1	2.5" Drive Hot-Swap Backplane Overview.....	82
4.1.2	Cypress* CY8C22545 Enclosure Management Controller.....	83
4.2	3.5" Hard Disk Drive Support	84
4.2.1	3.5" Drive Hot-Swap Backplane Overview.....	85
4.2.2	Cypress* CY8C22545 Enclosure Management Controller.....	87
4.3	SAS Expander Card Option	87
4.3.1	Protocol Support	90
4.3.2	SAS Expander Features.....	90
4.4	Optical Drive Support	90
4.5	Low Profile eUSB SSD Support	91
5.	Reliability and Availability.....	92
5.1	Mean Time between Failure	92
6.	Environmental Limits	95
6.1	System Environment Limits.....	95
6.2	System Environmental Testing.....	95
Appendix A: Integration and Usage Tips		97
Glossary		98
Reference Documents		100

List of Figures

Figure 1. Internal Chassis View of Intel® Server System P4208IP4LHGC.....	6
Figure 2. Internal Chassis View of Intel® Server System P4216IP4LHJC.....	7
Figure 3. Internal Chassis View of Intel® Server System P4216IP4LHKC.....	8
Figure 4. Internal Chassis View of Intel® Server System P4224IP4LHKC.....	9
Figure 5. Internal Chassis View of Intel® Server System P4308IP4LHGC.....	10
Figure 6. Internal Chassis View of Intel® Server System P4308IP4LHJC.....	11
Figure 7. Internal Chassis View of Intel® Server System P4308IP4LHKC.....	12
Figure 8. Internal Chassis View of Intel® Workstation System P4304CR2LFGN.....	13
Figure 9. Internal Chassis View of Intel® Workstation System P4304CR2LFJN.....	14
Figure 10. Internal Chassis View of Intel® Workstation System P4304CR2LFKN.....	15
Figure 11. Front Control Panel LED/Button Arrangement.....	16
Figure 12. Back panel feature.....	19
Figure 13. Hot-Swap Hard Disk Drive Cage.....	20
Figure 14. Front Closed Chassis View for Fixed Hard Drives Configuration.....	21
Figure 15. Front Closed Chassis View for Hot-swap Hard Drives Configuration.....	21
Figure 16. 750-W Power Supply Outline Drawing.....	23
Figure 17. Differential Noise test setup.....	31
Figure 18. Turn On/Off Timing (Power Supply Signals).....	32
Figure 19. PSON# Required Signal Characteristic.....	34
Figure 20. Power Supply Outline Drawing.....	36
Figure 21. Differential Noise test setup.....	44
Figure 22. PSON# Required Signal Characteristic.....	47
Figure 23. PWOK Circuit Requirement.....	48
Figure 24. Power Supply Outline Drawing.....	50
Figure 25 Differential Noise test setup.....	57
Figure 26 Turn On/Off Timing (Power Supply Signals).....	59
Figure 27. PSON# Required Signal Characteristic.....	61
Figure 28. PWOK Circuit Requirement.....	62
Figure 30. Outline Drawing.....	64
Figure 30. Airflow Diagram.....	65
Figure 31. Differential Noise test setup.....	74

Figure 32. Fixed Fans in Intel® Workstation System P4000CR	79
Figure 33. Hot-swap Fans in Intel® Server System P4000IP	80
Figure 34. 2.5" Hard Disk Drive Cage	81
Figure 35. 2.5" Hard Disk Drive Support - LED Status	82
Figure 36. 2.5" Backplane, Front Side	82
Figure 37. 2.5" Backplane, Back Side.....	83
Figure 38. 3.5" Hard Disk Drive Cage	84
Figure 39. 3.5" Hard Disk Drive Support - LED Status	84
Figure 40. 3.5" Backplane, Front Side	85
Figure 41. 2.5" Backplane, Back Side.....	86
Figure 42. Internal SAS Expander Installation.....	87
Figure 43. Internal 24-Port SAS Expander Card	87
Figure 44. 24-Port Expander SAS Connector/Drive Identification Block Diagram	88
Figure 45. Internal 36-Port SAS Expander Card	88
Figure 46. 36-Port Expander SAS Connector/Drive Identification Block Diagram	88
Figure 47. Optical Drive	90
Figure 48. eUSB SSD Support.....	91

List of Tables

Table 1. Intel® Server System P4000IP Hot-Swap 3.5 HDDs and Non-HDD configuration base feature	3
Table 2. Intel® Server System P4000IP Hot-Swap 2.5 HDDs configuration base feature	4
Table 3. Intel® Workstation System P4000CR Fixed 3.5 HDDs configuration base feature	4
Table 4. Power/Sleep LED Functional States.....	17
Table 5. Front Control Panel LED Status	18
Table 6. DC Output Connector.....	23
Table 7. LED Characteristics	24
Table 8. Power Supply LED Functionality	24
Table 9. Environmental Requirements	25
Table 10. Power Factor Requirements for Computer Servers.....	26
Table 11. AC Input Voltage Range	26
Table 12. AC Line Holdup Time	26
Table 13. AC Line Sag Transient Performance.....	27
Table 14. AC Line Surge Transient Performance.....	27
Table 15. Silver Efficiency Requirement	28
Table 16. Minimum Load Ratings.....	28
Table 17. Voltage Regulation Limits.....	29
Table 18. Transient Load Requirements	29
Table 19. Capacitive Loading Conditions	29
Table 20. Ripples and Noise	30
Table 21. Timing Requirements	31
Table 22. Over Current Protection	33
Table 23. Over Voltage Protection (OVP) Limits for 750W PSU	33
Table 24. PSON# Signal Characteristic	33
Table 25. PWOK Signal Characteristics.....	34
Table 26. SMBAlert# Signal Characteristics.....	35
Table 27. DC Output Connector.....	37
Table 28. LED Characteristics	38
Table 29. LED Status.....	38
Table 30. Environmental Requirements	38
Table 31. AC Input Voltage Range	39

Table 32. AC Line Sag Transient Performance.....	41
Table 33. AC Line Surge Transient Performance.....	41
Table 34. Platinum Efficiency Requirement.....	41
Table 35. Minimum Load Ratings.....	42
Table 36. Voltage Regulation Limits.....	42
Table 37. Transient Load Requirements	43
Table 38. Capacitive Loading Conditions	43
Table 39. Ripples and Noise	44
Table 40. Timing Requirements	45
Table 41. Over Current Protection	46
Table 42. Over Voltage Protection (OVP) Limits for 1200W PSU	46
Table 43. PSON# Signal Characteristic	46
Table 44. PWOK Signal Characteristics.....	47
Table 45. SMBAlert# Signal Characteristics.....	48
Table 46. DC Output Connector.....	50
Table 47. LED Characteristics	51
Table 48. LED Indicator States	51
Table 49 Environmental Requirements	52
Table 50 Environmental Requirements	52
Table 51 AC Input Voltage Range	53
Table 52. AC Line Holdup Time	53
Table 53 AC Line Sag Transient Performance.....	54
Table 54 AC Line Surge Transient Performance.....	54
Table 55 Platinum Efficiency Requirement.....	54
Table 56 Minimum Load Ratings.....	55
Table 57 Voltage Regulation Limits.....	55
Table 58. Transient Load Requirements	55
Table 59. Capacitive Loading Conditions	56
Table 60. Ripples and Noise	57
Table 61. Timing Requirements	58
Table 62 Over Current Protection	59
Table 63. Over Voltage Protection (OVP) Limits for 1600W PSU	60
Table 64 PSON# Signal Characteristic	60
Table 65 PWOK Signal Characteristics.....	61

Table 66. SMBAlert# Signal Characteristics.....	62
Table 67. Thermal Requirements.....	65
Table 68. Input Connector and Pin Assignment Diagrams	66
Table 69. PDB Cable Length	66
Table 70. P1 Baseboard Power Connector	67
Table 71. P0 Processor Power Connector	68
Table 72. P1 Processor Power Connector	68
Table 73. Power Signal Connector.....	68
Table 74. P12 12V connectors.....	69
Table 75. P13 - P16 12V connectors	69
Table 76. P8, P9, P10, P11 Legacy Peripheral Power Connectors	69
Table 77. P7 Legacy Peripheral Power Connectors.....	69
Table 78. SATA Peripheral Power Connectors	69
Table 79. Remote Sense Connection Points.....	70
Table 80. Remote Sense Requirements	70
Table 81. 12V Rail Distribution.....	71
Table 82. Hard Drive 12V rail configuration options	72
Table 83. DC/DC Converters Load Ratings	72
Table 84. 5VSB Loading	72
Table 85. Voltage Regulation Limits.....	73
Table 86. Transient Load Requirements	73
Table 87. Capacitive Loading Conditions	73
Table 88. Ripple and Noise	74
Table 89. Output Voltage Timing	74
Table 90. PDB Over Current Protection Limits/240VA Protection	76
Table 91. Over Voltage Protection (OVP) Limits	76
Table 92. System PWOK Requirements	76
Table 93. PDB addressing	77
Table 94. 2.5" Hard Disk Drive Status LED States.....	82
Table 95. 2.5" Hard Disk Drive Activity LED States.....	82
Table 96. 3.5" Hard Disk Drive Status LED States.....	84
Table 97. 3.5" Hard Disk Drive Activity LED States.....	85
Table 98. Calculated Mean Time Between Failure	92
Table 99. System Environment Limits Summary.....	95

<This page is intentionally left blank.>

1. Intel® Server System P4000IP and Intel® Workstation System Overview

Intel® Server System P4000IP and Intel® Workstation System is 4U pedestal, 27" length server chassis that is designed to support Intel® Server Board S2600IP and Intel® Workstation Board W2600CR. This chapter provides a high-level overview of the chassis features. Greater detail for each major chassis component or feature is provided in the following chapters.

1.1 Intergrated System family overview

Intel® Server System P4000IP and Intel® Workstation System make extensive use of tool-less hardware features and, depending on configuration and upgrade features, provides redundant power supply, redundant cooling and hot swappable hard drives capability. Intel® Server System P4000IP and Intel® Workstation System comes with the following configuration:

Your Intel® Workstation System P4304CR2LFJN(L) ships with the following items:

- One Intel® Workstation Board W2600CR2(L)
- One CRPS 1200W power supply, installed in the chassis
- One fixed system CPU zone fan, installed in the chassis
- One fixed system PCI zone fan, installed in the chassis
- Four fixed HDD carrier tray, installed in the chassis
- Front panel, installed in the chassis
- Front Bezel for fixed hard drive, EMI shield, 5.25" bay filler
- Pre-routing cables
- Two heat sinks

Your Intel® Workstation System P4304CR2LFGN ships with the following items:

- One Intel® Workstation Board W2600CR2
- One CRPS 750W power supply, installed in the chassis
- One fixed system CPU zone fan, installed in the chassis
- One fixed system PCI zone fan, installed in the chassis
- Four fixed HDD carrier tray, installed in the chassis
- Front panel, installed in the chassis
- Front Bezel for fixed hard drive, EMI shield, 5.25" bay filler
- Pre-routing cables
- Two heat sinks

Your Intel® Workstation System P4304CR2LFKN ships with the following items:

- One Intel® Workstation Board W2600CR2
- One CRPS 1600W power supply, installed in the chassis
- One fixed system CPU zone fan, installed in the chassis
- One fixed system PCI zone fan, installed in the chassis
- Four fixed HDD carrier tray, installed in the chassis
- Front panel, installed in the chassis
- Front Bezel for fixed hard drive, EMI shield, 5.25" bay filler
- Pre-routing cables
- Two heat sinks

Your Intel® Server System P4216IP4LHJC ships with the following items:

- One Intel® Server Board S2600IP4
- Two CRPS 1200W power supply, installed in the chassis
- Five hot-swap redundant system fans, installed in the chassis
- 16*2.5" hot-swap HDD cage with sixteen 2.5 HDD carrier, installed in the chassis
- Front panel, installed in the chassis
- Front Bezel for hot-swap hard drive, EMI shield, 5.25" bay filler
- Pre-routing cables
- Two heat sinks

Your Intel® Server System P4208IP4LHGC ships with the following items:

- One Intel® Server Board S2600IP4
- Two CRPS 750W power supply, installed in the chassis
- Five hot-swap redundant system fans, installed in the chassis
- 8*2.5" hot-swap HDD cage with eight 2.5 HDD carrier, installed in the chassis
- Front panel, installed in the chassis
- Front Bezel for hot-swap hard drive, EMI shield, 5.25" bay filler
- Pre-routing cables
- Two heat sinks

Your Intel® Server System P4308IP4LHJC(L) ships with the following items:

- One Intel® Server Board S2600IP4 (L)
- Two CRPS 1200W power supply, installed in the chassis
- Five hot-swap redundant system fans, installed in the chassis
- 8*3.5" hot-swap HDD cage with eight 3.5 HDD carrier, installed in the chassis
- Front panel, installed in the chassis
- Front Bezel for hot-swap hard drive, EMI shield, 5.25" bay filler
- Pre-routing cables
- Two heat sinks

Your Intel® Server System P4308IP4LHGC ships with the following items:

- One Intel® Server Board S2600IP
- Two CRPS 750W power supply, installed in the chassis
- Five hot-swap redundant system fans, installed in the chassis
- 8*3.5" hot-swap HDD cage with eight 3.5 HDD carrier, installed in the chassis
- Front panel, installed in the chassis
- Front Bezel for hot-swap hard drive, EMI shield, 5.25" bay filler
- Pre-routing cables
- Two heat sinks

Your Intel® Server System P4224IP4LHKC ships with the following items:

- One Intel® Server Board S2600IP
- Two CRPS 1600W power supply, installed in the chassis
- Five hot-swap redundant system fans, installed in the chassis
- 24*2.5" hot-swap HDD cage with twenty four 2.5 HDD carrier, installed in the chassis
- Front panel, installed in the chassis
- Front Bezel for hot-swap hard drive, EMI shield, 5.25" bay filler
- Pre-routing cables
- Two heat sinks

Your Intel® Server System P4216IP4LHKC ships with the following items:

- One Intel® Server Board S2600IP
- Two CRPS 1600W power supply, installed in the chassis
- Five hot-swap redundant system fans, installed in the chassis
- 16*2.5" hot-swap HDD cage with sixteen 2.5 HDD carrier, installed in the chassis
- Front panel, installed in the chassis
- Front Bezel for hot-swap hard drive, EMI shield, 5.25" bay filler
- Pre-routing cables
- Two heat sinks

Your Intel® Server System P4308IP4LHKC ships with the following items:

- One Intel® Server Board S2600IP
- Two CRPS 1600W power supply, installed in the chassis
- Five hot-swap redundant system fans, installed in the chassis
- 8*3.5" hot-swap HDD cage with eight 3.5 HDD carrier, installed in the chassis
- Front panel, installed in the chassis
- Front Bezel for hot-swap hard drive, EMI shield, 5.25" bay filler
- Pre-routing cables
- Two heat sinks

The following table summarizes the features for all System combinations:

Table 1. Intel® Server System P4000IP Hot-Swap 3.5 HDDs and Non-HDD configuration base feature

Feature	P4308IP4LHGC	P4308IP4LHJC (L)	P4308IP4LHKC
Dimensions	<ul style="list-style-type: none"> ▪ 438mm high ▪ 173mm wide ▪ 697mm deep 		
Hard Drives	8*3.5 hot-swap driver cage		
Peripherals	<ul style="list-style-type: none"> ▪ Three multi-mount 5.25" peripheral bays 		
Control Panel (dependent on option selected)	<ul style="list-style-type: none"> ▪ Front Panel ▪ Intel® Local Control Panel (Optional) 		
LEDs and displays (dependent on option selected)	<ul style="list-style-type: none"> ▪ With Front Panel <ul style="list-style-type: none"> ○ NIC1 Activity ○ NIC2 Activity ○ NIC3 Activity ○ NIC4 Activity ○ Power/Sleep ○ System Status ○ System Chassis Identification ○ Hard Drive Activity 		
Power Supply	<ul style="list-style-type: none"> ▪ Two hot-swap 750W common redundant power supply 	<ul style="list-style-type: none"> ▪ Two hot-swap 1200W common redundant power supply 	<ul style="list-style-type: none"> ▪ Two hot-swap 1600W common redundant power supply
Fans	<ul style="list-style-type: none"> ▪ Five hot-swap system fans 		
USB 2.0	<ul style="list-style-type: none"> ▪ Two front panel USB ports with Front Panel 		

Feature	P4308IP4LHGC	P4308IP4LHJC (L)	P4308IP4LHKC
	<ul style="list-style-type: none"> Four Back panel USB ports 		
Video	<ul style="list-style-type: none"> One rear panel video port 		

Table 2. Intel® Server System P4000IP Hot-Swap 2.5 HDDs configuration base feature

Feature	P4208IP4LHGC	P4216IP4LHJC	P4216IP4LHKC	P4224IP4LHKC
Dimensions	<ul style="list-style-type: none"> 438mm high 173mm wide 697mm deep 			
Hard Drives	<ul style="list-style-type: none"> One 8x2.5" Hot-swap HDD cage support up to 8x2.5" hot-swap HDDs 	<ul style="list-style-type: none"> Two 8x2.5" Hot-swap HDD cage support up to 16x2.5" hot-swap HDDs 	<ul style="list-style-type: none"> Two 8x2.5" Hot-swap HDD cage support up to 16x2.5" hot-swap HDDs 	<ul style="list-style-type: none"> Three 8x2.5" Hot-swap HDD cage support up to 24x2.5" hot-swap HDDs
Peripherals	<ul style="list-style-type: none"> Three multi-mount 5.25" peripheral bays 			<ul style="list-style-type: none"> one multi-mount 5.25" peripheral bays
Control Panel (dependent on option selected)	<ul style="list-style-type: none"> Front Panel Intel® Local Control Panel (Optional) 			
LEDs and displays (dependent on option selected)	<ul style="list-style-type: none"> With Front Panel <ul style="list-style-type: none"> NIC1 Activity NIC2 Activity NIC3 Activity NIC4 Activity Power/Sleep System Status System Chassis Identification Hard Drive Activity 			
Power Supply	<ul style="list-style-type: none"> Two hot-swap 750W common redundant power supply 	<ul style="list-style-type: none"> Two hot-swap 1200W common redundant power supply 	<ul style="list-style-type: none"> Two hot-swap 1600W common redundant power supply 	<ul style="list-style-type: none"> Two hot-swap 1600W common redundant power supply
Fans	<ul style="list-style-type: none"> Five hot-swap system fans 			
USB 2.0	<ul style="list-style-type: none"> Two front panel USB ports with Front Panel Four Back panel USB ports (depending on server/workstation board) 			
Video	<ul style="list-style-type: none"> One rear panel video port 			

Table 3. Intel® Workstation System P4000CR Fixed 3.5 HDDs configuration base feature

Feature	P4304CR2LFGN	P4304CR2LFIN(L)	P4304CR2LFKN
Dimensions	<ul style="list-style-type: none"> 17.2 inches high 6.8 inches wide 25 inches deep (without bezel: 24.5 inches) 		
Hard Drives	<ul style="list-style-type: none"> Four Fixed 3.5" HDDs tray 		
Peripherals	<ul style="list-style-type: none"> Three multi-mount 5.25 peripheral bays 		
Control Panel (dependent on)	<ul style="list-style-type: none"> Front Panel Intel® Local Control Panel (Optional) 		

Intel® Server System P4000IP and Intel® Workstation System P4000CR Family TPS
Intel® Server System P4000IP and Intel® Workstation System Overview

Feature	P4304CR2LFGN	P4304CR2LFJN(L)	P4304CR2LFKN
option selected)			
LEDs and displays (dependent on option selected)	<ul style="list-style-type: none"> ▪ With Front Panel <ul style="list-style-type: none"> ○ NIC1 Activity ○ NIC2 Activity ○ NIC3 Activity (no functional) ○ NIC4 Activity (no functional) ○ Power/Sleep ○ System Status ○ System Chassis Identification ○ Hard Drive Activity 		
Power Supply	<ul style="list-style-type: none"> ▪ Two hot-swap 750W common redundant power supply 	<ul style="list-style-type: none"> ▪ Two hot-swap 1200W common redundant power supply 	<ul style="list-style-type: none"> ▪ Two hot-swap 1600W common redundant power supply
Fans	<ul style="list-style-type: none"> ▪ One fixed system CPU zone fan ▪ One fixed system PCI zone fan 		
USB 2.0 and USB 3.0	<ul style="list-style-type: none"> ▪ Two front panel USB ports with Front Panel ▪ Two Back panel USB ports ▪ Two Back panel USB 3.0 ports 		
Video	<ul style="list-style-type: none"> ▪ One onboard internal video header 		

1.1.1

Intel® Server System P4208IP4LHGC View

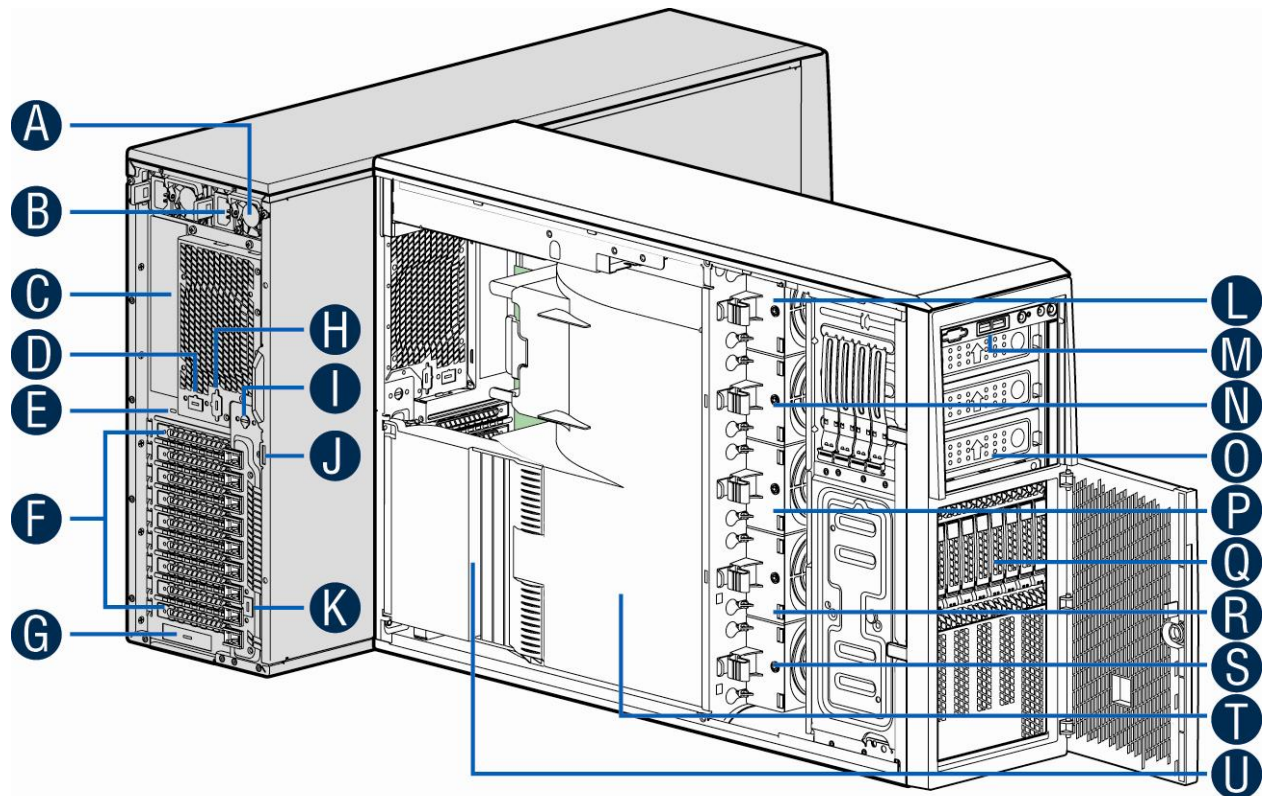

AF005134

- A. 750W CRPS Power supply
- B. AC Input Power connector
- C. I/O ports
- D. Serial port knockout
- E. A Kensington cable lock mounting hole
- F. PCI Add-in card slot covers
- G. IO module slot cover
- H. Alternate knockout
- I. Opening for SPDIF cable
- J. Padlock loop
- K. RMM4 knockout
- L. Hot swap system fan 5
- M. Front panel
- N. Hot swap system fan 4
- O. 5.25" peripheral bays
- P. Hot swap system fan 3
- Q. One 8x2.5" Hot-swap HDD Cage
- R. Hot swap system fan 2
- S. Hot swap system fan 1
- T. Air duck
- U. PCI card retainer

Figure 1. Internal Chassis View of Intel® Server System P4208IP4LHGC

1.1.2

Intel® Server System P4216IP4LHJC View

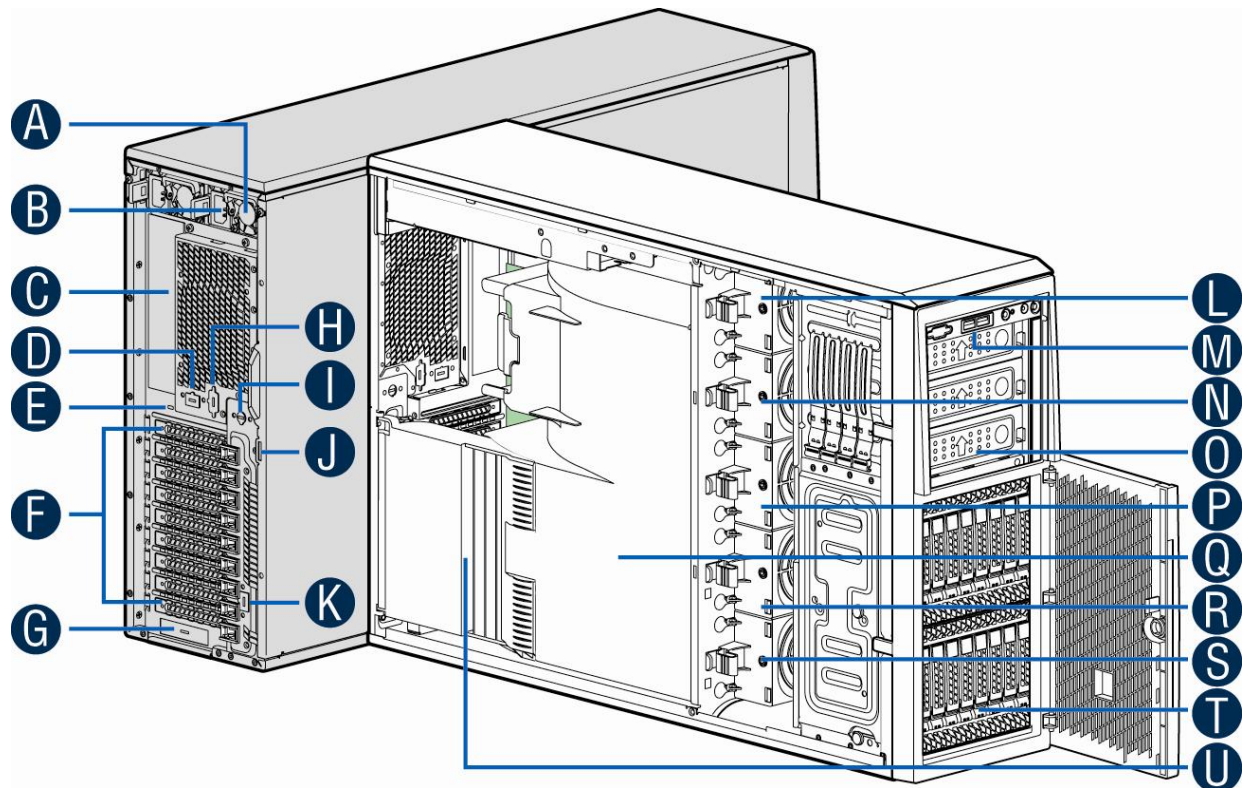

AF004945

- A. 1200W CRPS Power supply
- B. AC Input Power connector
- C. I/O ports
- D. Serial port knockout
- E. A Kensington cable lock mounting hole
- F. PCI Add-in card slot covers
- G. IO module slot cover
- H. Alternate knockout
- I. Opening for SPDIF cable
- J. Padlock loop
- K. RMM4 knockout
- L. Hot swap system fan 5
- M. Front panel
- N. Hot swap system fan 4
- O. 5.25" peripheral bays
- P. Hot swap system fan 3
- Q. Air duck
- R. Hot swap system fan 2
- S. Hot swap system fan 1
- T. Two 8x2.5" Hot-swap HDD Cage
- U. PCI card retainer

Figure 2. Internal Chassis View of Intel® Server System P4216IP4LHJC

1.1.3

Intel® Server System P4216IP4LHKC View

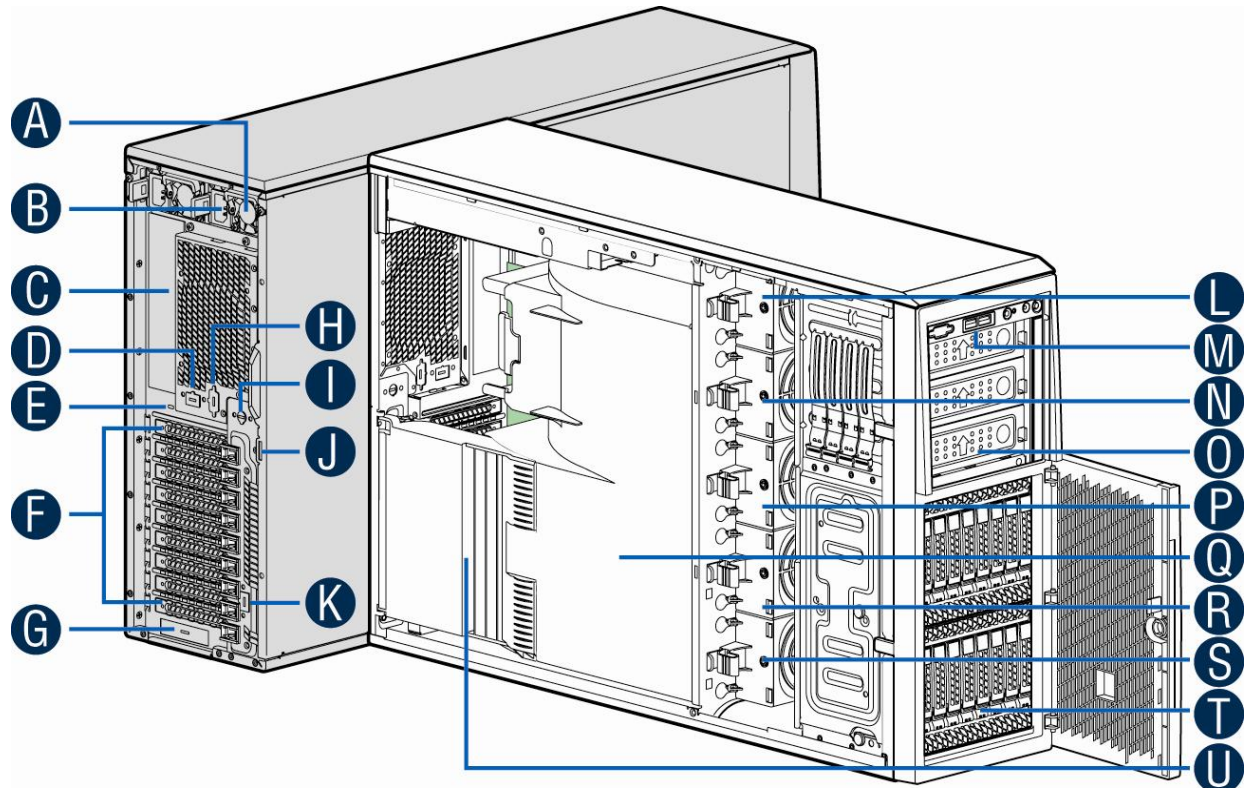

AF004945

- A. 1600W CRPS Power supply
- B. AC Input Power connector
- C. I/O ports
- D. Serial port knockout
- E. A Kensington cable lock mounting hole
- F. PCI Add-in card slot covers
- G. IO module slot cover
- H. Alternate knockout
- I. Opening for SPDIF cable
- J. Padlock loop
- K. RMM4 knockout
- L. Hot swap system fan 5
- M. Front panel
- N. Hot swap system fan 4
- O. 5.25" peripheral bays
- P. Hot swap system fan 3
- Q. Air duck
- R. Hot swap system fan 2
- S. Hot swap system fan 1
- T. Two 8x2.5" Hot-swap HDD Cage
- U. PCI card retainer

Figure 3. Internal Chassis View of Intel® Server System P4216IP4LHKC

1.1.4 Intel® Server System P4224IP4LHKC View

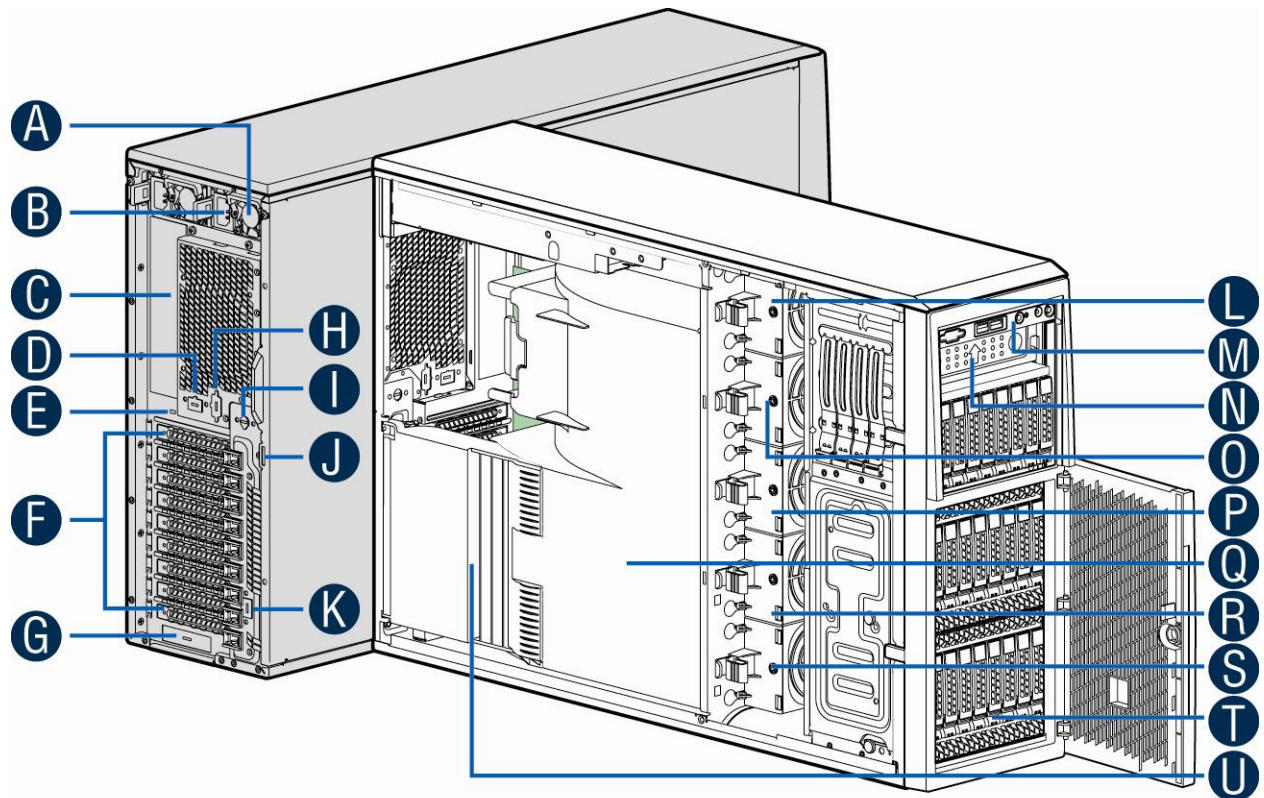

AF005135

- A. 1600W CRPS Power supply
- B. AC Input Power connector
- C. I/O ports
- D. Serial port knockout
- E. A Kensington cable lock mounting hole
- F. PCI Add-in card slot covers
- G. IO module slot cover
- H. Alternate knockout
- I. Opening for SPDIF cable
- J. Padlock loop
- K. RMM4 knockout
- L. Hot swap system fan 5
- M. Front panel
- N. 5.25" peripheral bays
- O. Hot swap system fan 4
- P. Hot swap system fan 3
- Q. Air duck
- R. Hot swap system fan 2
- S. Hot swap system fan 1
- T. Three 8x2.5" Hot-swap HDD Cage
- U. PCI card retainer

Figure 4. Internal Chassis View of Intel® Server System P4224IP4LHKC

1.1.5

Intel® Server System P4308IP4LHGC View

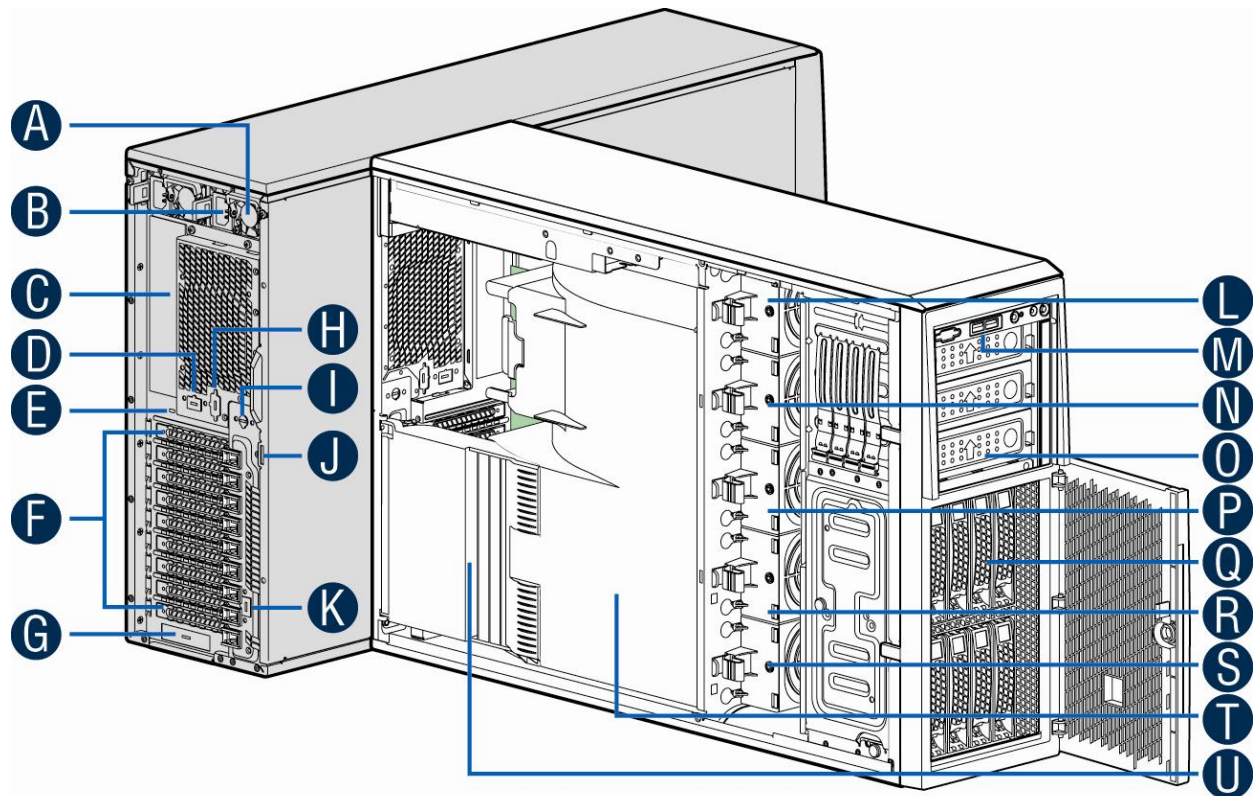

AF005137

- A. 750W CRPS Power supply
- B. AC Input Power connector
- C. I/O ports
- D. Serial port knockout
- E. A Kensington cable lock mounting hole
- F. PCI Add-in card slot covers
- G. IO module slot cover
- H. Alternate knockout
- I. Opening for SPDIF cable
- J. Padlock loop
- K. RMM4 knockout
- L. Hot swap system fan 5
- M. Front panel
- N. Hot swap system fan 4
- O. 5.25" peripheral bays
- P. Hot swap system fan 3
- Q. One 8x3.5" Hot-swap HDD Cage
- R. Hot swap system fan 2
- S. Hot swap system fan 1
- T. Air duck
- U. PCI card retainer

Figure 5. Internal Chassis View of Intel® Server System P4308IP4LHGC

1.1.6

Intel® Server System P4308IP4LHJC(L) View

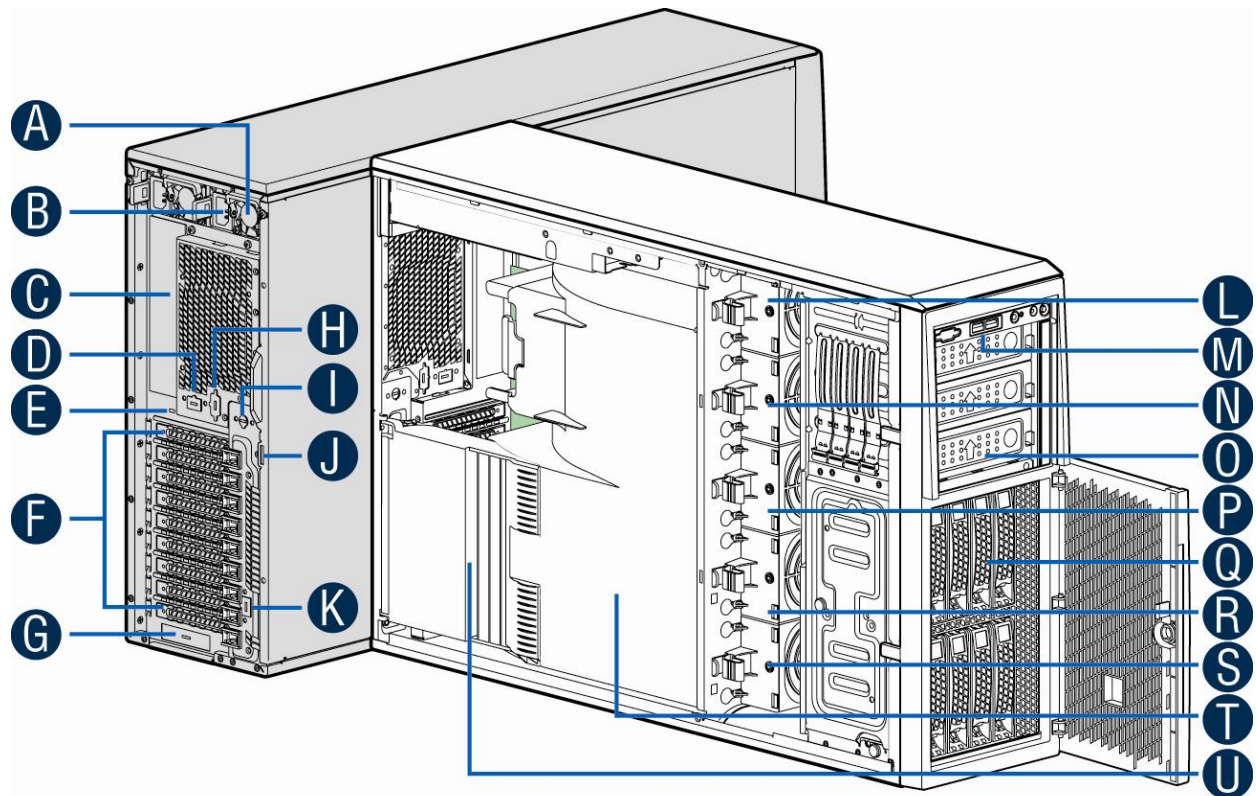

AF005137

- A. 1200W CRPS Power supply
- B. AC Input Power connector
- C. I/O ports
- D. Serial port knockout
- E. A Kensington cable lock mounting hole
- F. PCI Add-in card slot covers
- G. IO module slot cover
- H. Alternate knockout
- I. Opening for SPDIF cable
- J. Padlock loop
- K. RMM4 knockout
- L. Hot swap system fan 5
- M. Front panel
- N. Hot swap system fan 4
- O. 5.25" peripheral bays
- P. Hot swap system fan 3
- Q. One 8x3.5" Hot-swap HDD Cage
- R. Hot swap system fan 2
- S. Hot swap system fan 1
- T. Air duck
- U. PCI card retainer

Figure 6. Internal Chassis View of Intel® Server System P4308IP4LHJC

1.1.7

Intel® Server System P4308IP4LHKC View

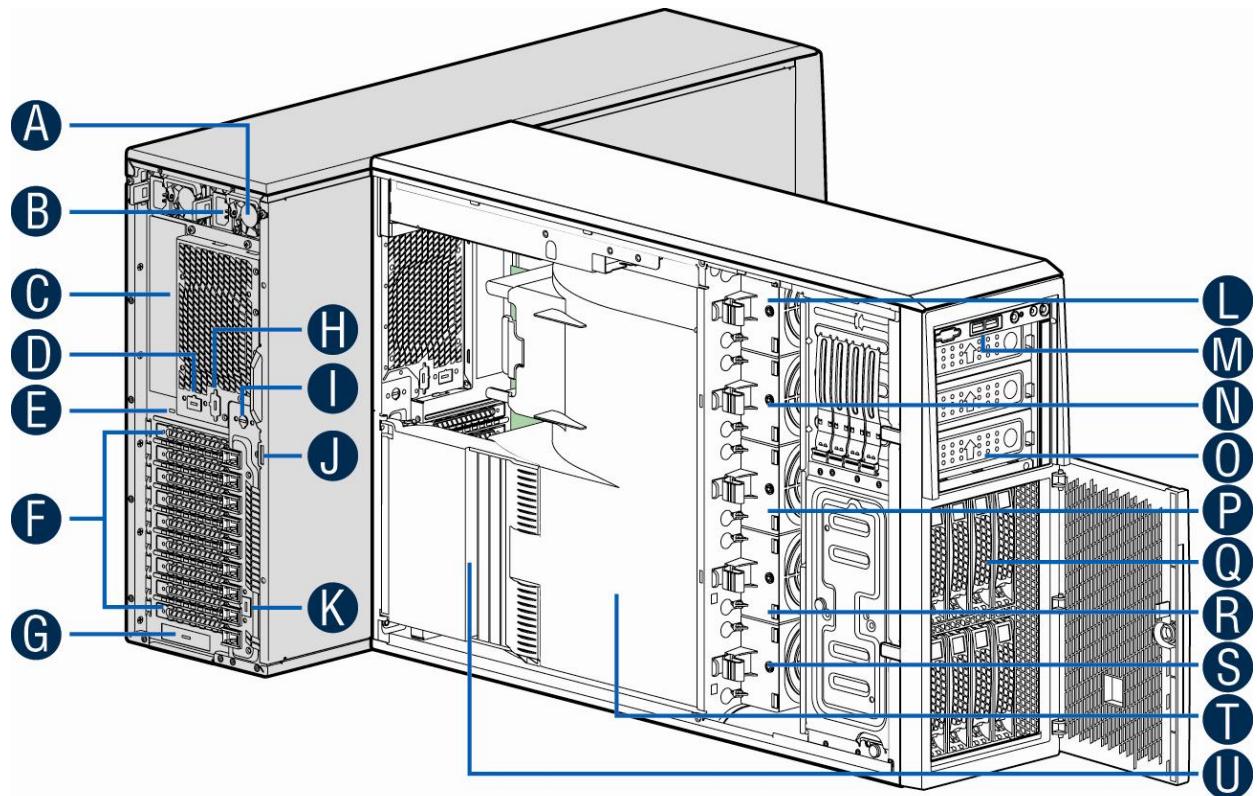

AF005137

- A. 1600W CRPS Power supply
- B. AC Input Power connector
- C. I/O ports
- D. Serial port knockout
- E. A Kensington cable lock mounting hole
- F. PCI Add-in card slot covers
- G. IO module slot cover
- H. Alternate knockout
- I. Opening for SPDIF cable
- J. Padlock loop
- K. RMM4 knockout
- L. Hot swap system fan 5
- M. Front panel
- N. Hot swap system fan 4
- O. 5.25" peripheral bays
- P. Hot swap system fan 3
- Q. One 8x3.5" Hot-swap HDD Cage
- R. Hot swap system fan 2
- S. Hot swap system fan 1
- T. Air duck
- U. PCI card retainer

Figure 7. Internal Chassis View of Intel® Server System P4308IP4LHKC

1.1.8

Intel® Workstation System P4304CR2LFGN View

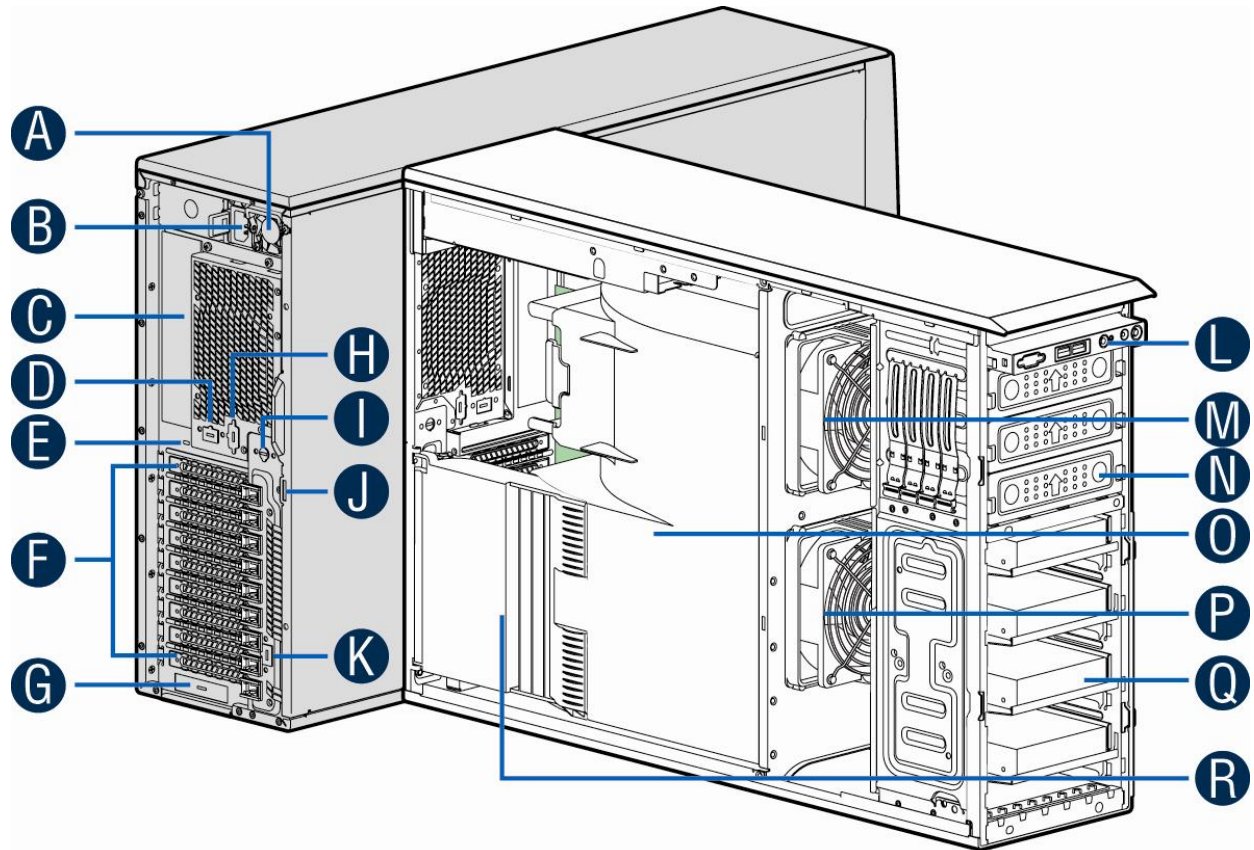

AF004944

- A. 750W CRPS Power supply
- B. AC Input Power connector
- C. I/O ports
- D. Serial port knockout
- E. A Kensington cable lock mounting hole
- F. PCI Add-in card slot covers
- G. IO module slot cover
- H. Alternate knockout
- I. Opening for SPDIF cable
- J. Padlock loop
- K. RMM4 knockout
- L. Front panel
- M. CPU zone system fan(fan 2)
- N. 5.25" peripheral bays
- O. Air duck
- P. PCI zone system fan(fan 1)
- Q. Fixed Hard driver carrier tray
- R. PCI card retainer

Figure 8. Internal Chassis View of Intel® Workstation System P4304CR2LFGN

1.1.9

Intel® Workstation System P4304CR2LFJN(L) View

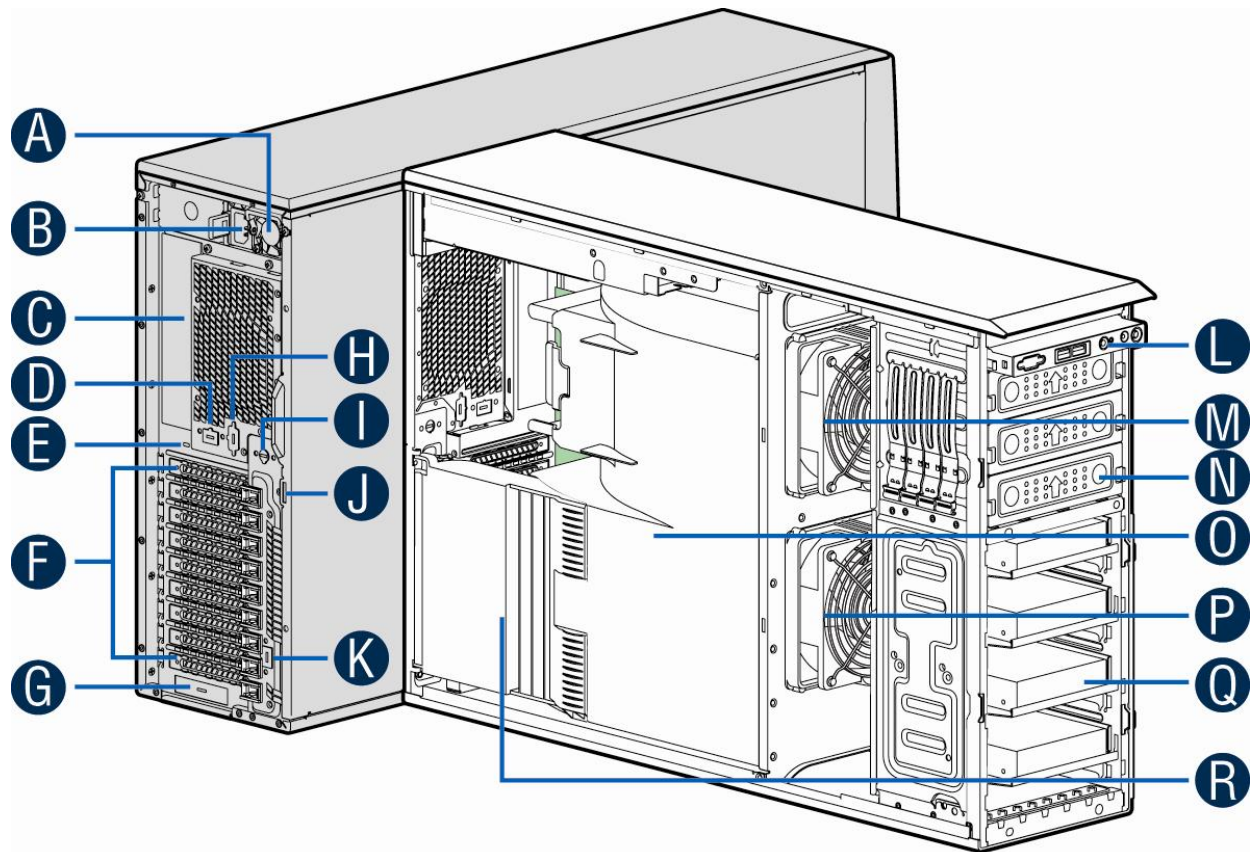

AF004944

- A. 1200W CRPS Power supply
- B. AC Input Power connector
- C. I/O ports
- D. Serial port knockout
- E. A Kensington cable lock mounting hole
- F. PCI Add-in card slot covers
- G. IO module slot cover
- H. Alternate knockout
- I. Opening for SPDIF cable
- J. Padlock loop
- K. RMM4 knockout
- L. Front panel
- M. CPU zone system fan(fan 2)
- N. 5.25" peripheral bays
- O. Air duck
- P. PCI zone system fan(fan 1)
- Q. Fixed Hard driver carrier tray
- R. PCI card retainer

Figure 9. Internal Chassis View of Intel® Workstation System P4304CR2LFJN

1.1.10

Intel® Workstation System P4304CR2LFKN View

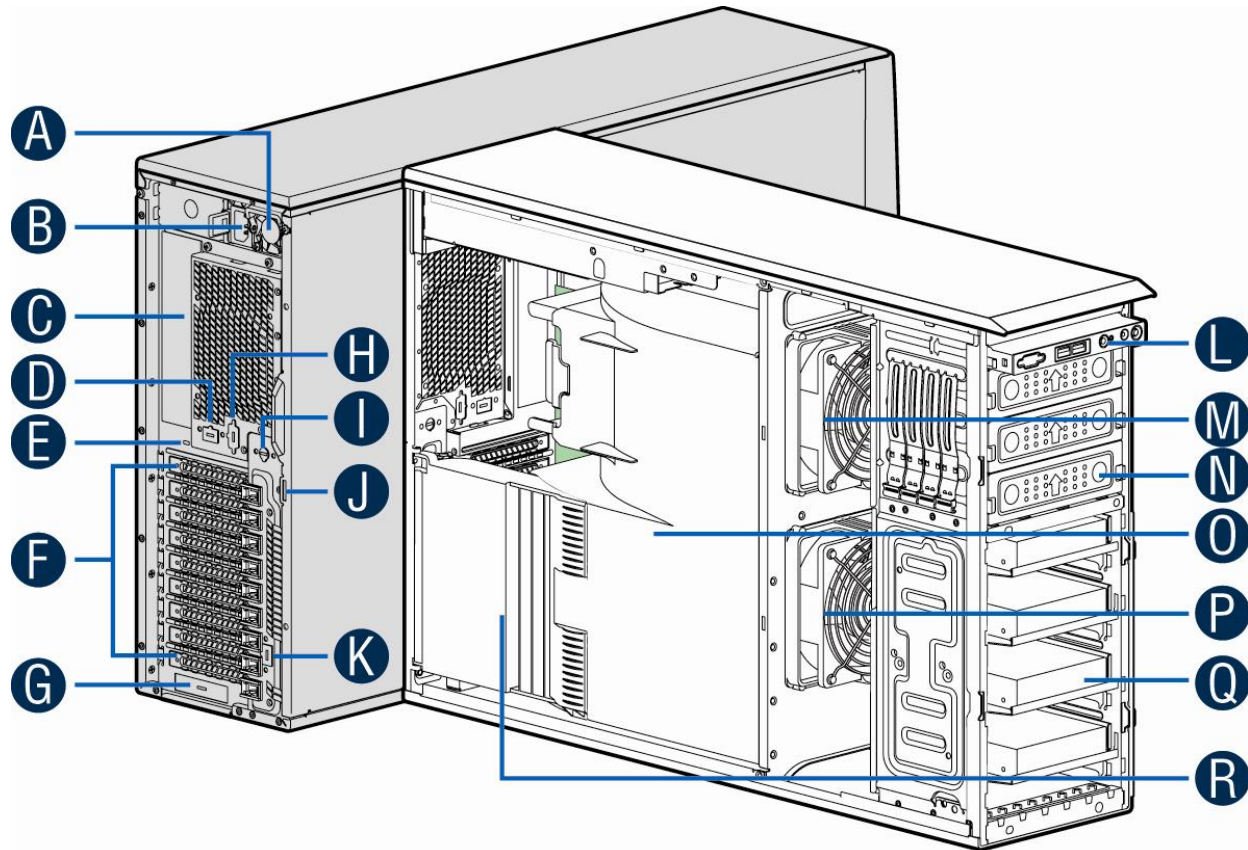

AF004944

- A. 1600W CRPS Power supply
- B. AC Input Power connector
- C. I/O ports
- D. Serial port knockout
- E. A Kensington cable lock mounting hole
- F. PCI Add-in card slot covers
- G. IO module slot cover
- H. Alternate knockout
- I. Opening for SPDIF cable
- J. Padlock loop
- K. RMM4 knockout
- L. Front panel
- M. CPU zone system fan(fan 2)
- N. 5.25" peripheral bays
- O. Air duck
- P. PCI zone system fan(fan 1)
- Q. Fixed Hard driver carrier tray
- R. PCI card retainer

Figure 10. Internal Chassis View of Intel® Workstation System P4304CR2LFKN

1.2 Chassis dimensions

Length:

656 mm (without bezel)

698.3 mm (with bezel)

Height:

438 mm

Width:

173 mm

1.3 Front control panel feature Overview

This Front Control Panel conforms to SSI specification with one exception that up to 4 LAN act/link LEDs are supported. The common front panel can support either the standard SSI 2x12 cable interconnect (2 LAN ports) or an Intel customized 2x15 cable interconnect (4 LAN ports).

The Front Control Panel has the following features:

- Power button with integrated power LED (green)
- System ID with integrated ID LED (blue)
- System Status LED (green/amber)
- System Reset button
- HDD activity LED
- HDD activity LED
- 4 NIC activity/link LEDs
- NMI button
- Two USB ports

1.3.1 Front Control Panel LED/Button Functionality

The following figure shows the layout of Front Control Panel:

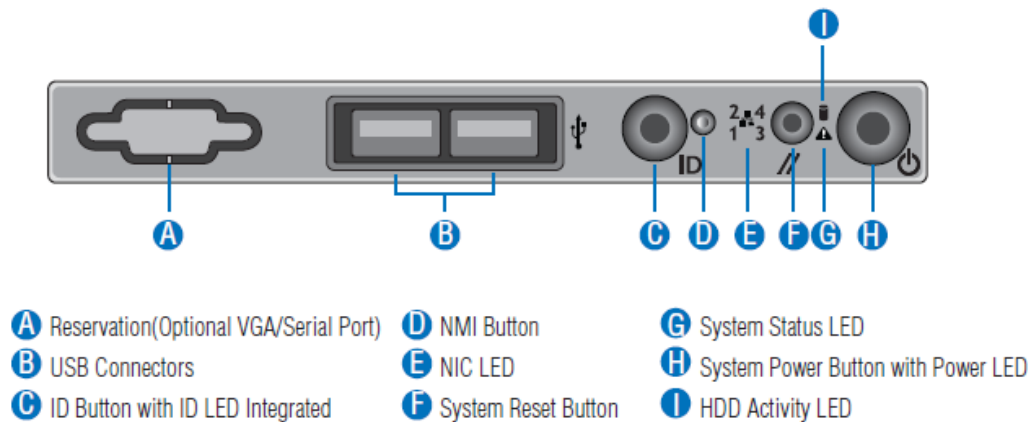

Figure 11. Front Control Panel LED/Button Arrangement

ID Button with integrated ID LED – Toggles the integrated ID LED and the Blue server board ID LED on and off. The ID LED is used to identify the system for maintenance when installed in a rack of similar server systems. The ID LED can also be toggled on and off remotely using the IPMI “Chassis Identify” command which will cause the LED to blink for 15 seconds.

NMI Button – When the NMI button is pressed, it puts the server in a halt state and issues a non-maskable interrupt (NMI). This can be useful when performing diagnostics for a given issue where a memory download is necessary to help determine the cause of the problem. To prevent an inadvertent system halt, the actual NMI button is located behind the Front Control Panel faceplate where it is only accessible with the use of a small tipped tool like a pin or paper clip.

Network Activity LEDs (NIC LED) – The Front Control Panel includes an activity LED indicator for each on-board Network Interface Controller (NIC). When a network link is detected, the LED will turn on solid. The LED will blink once network activity occurs at a rate that is consistent with the amount of network activity that is occurring.

System Reset Button – When pressed, this button will reboot and re-initialize the system.

System Status LED – The System Status LED is a bi-color (Green/Amber) indicator that shows the current health of the server system. The system provides two locations for this feature; one is located on the Front Control Panel, the other is located on the back edge of the server board, viewable from the back of the system. Both LEDs are tied together and will show the same state. The System Status LED states are driven by the on-board platform management sub-system.

System Power Button with power LED – Toggles the system power on and off. This button also functions as a sleep button if enabled by an ACPI compliant operating system. Pressing this button will send a signal to the iBMC, which will either power on or power off the system. The integrated LED is a single color (Green) and is capable of supporting different indicator states as defined in the following table.

Table 4. Power/Sleep LED Functional States

State	Power Mode	LED	Description
Power-off	Non-ACPI	Off	System power is off, and the BIOS has not initialized the chipset.
Power-on	Non-ACPI	On	System power is on
S5	ACPI	Off	Mechanical is off, and the operating system has not saved any context to the hard disk.
S4	ACPI	Off	Mechanical is off. The operating system has saved context to the hard disk.
S3-S1	ACPI	Slow blink ¹	DC power is still on. The operating system has saved context and gone into a level of low-power state.
S0	ACPI	Steady on	System and the operating system are up and running.

HDD Activity LED - The drive activity LED on the front panel indicates drive activity from the on-board hard disk controllers. The server board also provides a header giving access to this LED for add-in controllers.

USB Ports – In addition, the front panel provides two USB ports. The USB ports are cabled to the 2x5 connector on the server board.

1.3.2 Front Control Panel LED Status

The following table provides a description of each LED status.

Table 5. Front Control Panel LED Status

LED	Color	Condition	What It Means
Power/Sleep	Green	On	Power on or S0 sleep.
	Green	Blink	S1 sleep or S3 standby only for workstation baseboards.
		Off	Off (also sleep S4/S5 modes).
Status	Green	On	System ready/No alarm.
	Green	Blink	System ready, but degraded: redundancy lost such as PS or fan failure; non-critical temp/voltage threshold; battery failure; or predictive PS failure.
	Amber	On	Critical alarm: Voltage, thermal, or power fault; CPU missing; insufficient power unit redundancy resource offset asserted.
	Amber	Blink	Non-Critical failure: Critical temp/voltage threshold; VDR hot asserted; min number fans not present or failed.
		Off	AC power off: System unplugged. AC power on: System powered off and in standby, no prior degraded/non-critical/critical state.
Global HDD Activity	Green	Blink	HDD access.
		Off	No access and no fault.
LAN 1-4 Activity/Link	Green	On	LAN link
	Green	Blink	LAN access.
		Off	Idle.
Chassis Identification	Blue	On	Front panel chassis ID button pressed.
	Blue	Blink	Unit selected for identification by software.
		Off	No identification.

1.4 Back panel feature Overview

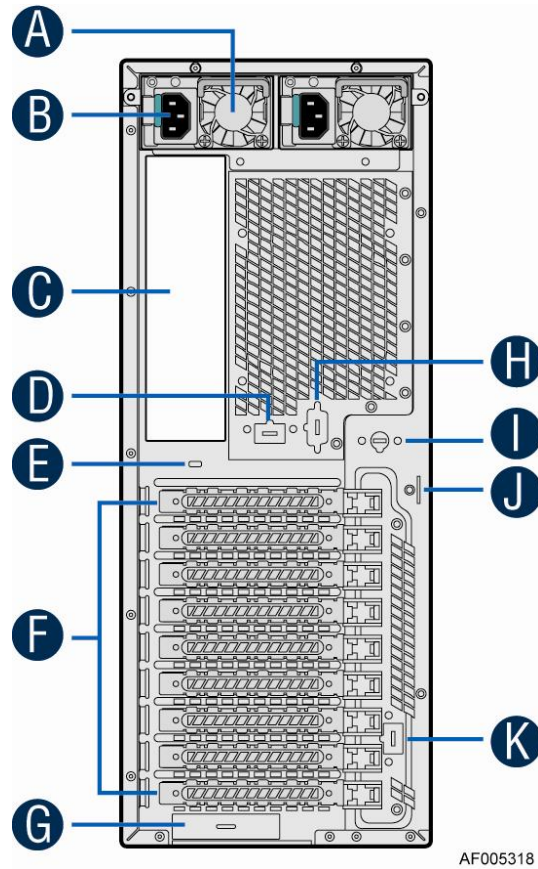

A	CRPS Power supply	G	IO module slot cover
B	AC Input Power connector	H	Alternate RMM4 knockout
C	I/O ports	I	Opening for SPDIF cable
D	Serial port knockout	J	Padlock loop
E	A Kensington cable lock mounting hole	K	RMM4 knockout
F	PCI Add-in card slot covers		

Figure 12. Back panel feature

1.5 Hot swap Hard Drivers and front panel options

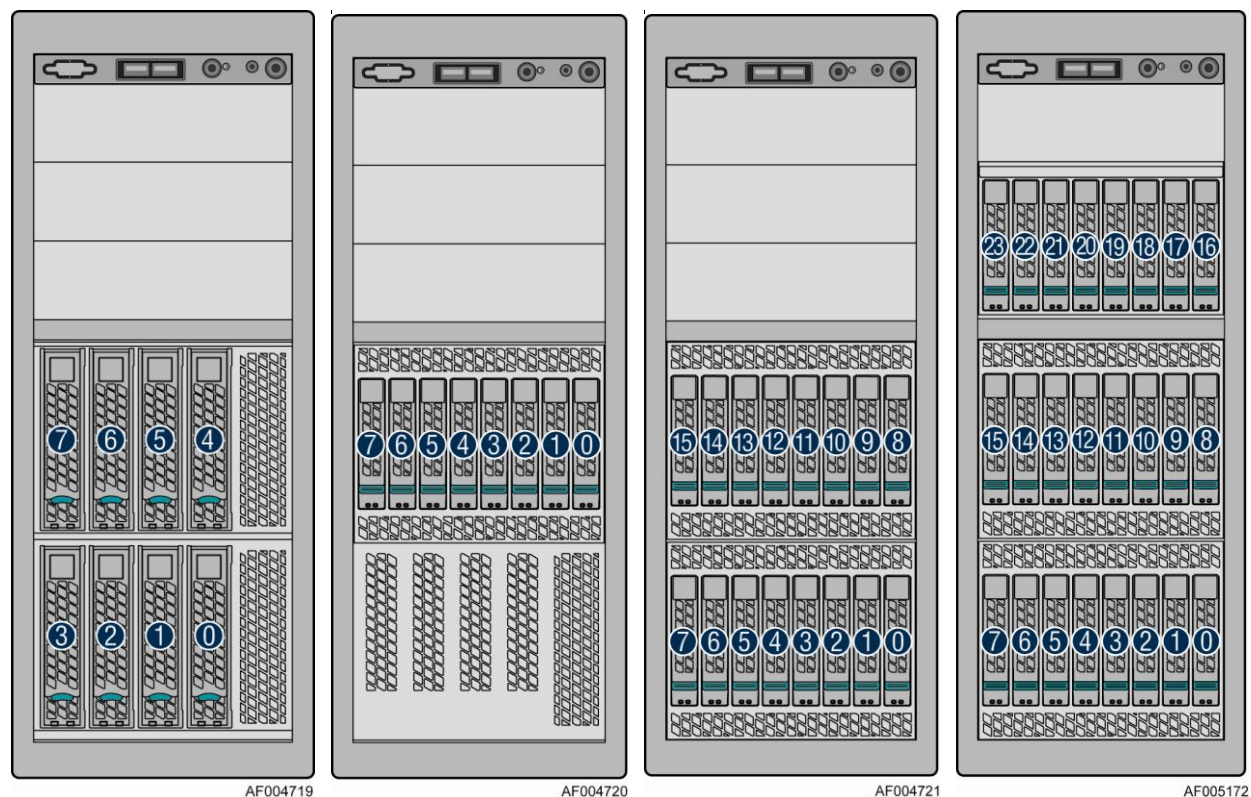

Figure 13. Hot-Swap Hard Disk Drive Cage

1.6 Chassis Security

A variety of chassis security options are provided at the system level:

- A removable padlock loop at the rear of the system access cover can be used to prevent access to the microprocessors, memory, and add-in cards. A variety of lock sizes can be accommodated by the 0.270-inch diameter loop.
- A Kensington* cable lock mounting hole is provided on the rear chassis I/O panel.
- A chassis intrusion switch is provided, allowing server management software to detect unauthorized access to the system side cover.
- In hot-swap hard drives configuration, a door lock is provided on the front bezel assembly with the door to prevent access to the hot-swap hard drives and the interior of the chassis.

Note: See the technical product specification appropriate to the server board and System Service Guide for a description of BIOS and management security features for each specific supported platform. Technical product specifications can be found at <http://www.intel.com/support>.

1.7 Front Bezel Features

There are two type of front bezel assembly.

1. Front bezel assembly for fixed hard drives configuration on Intel® Workstation System P4000CR.

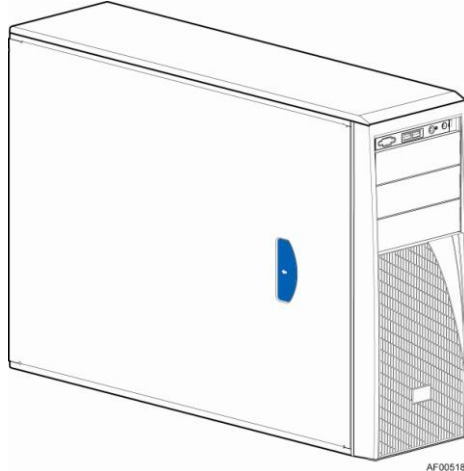
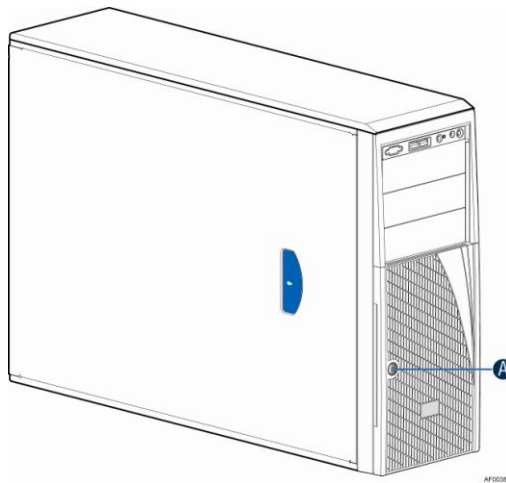

Figure 14. Front Closed Chassis View for Fixed Hard Drives Configuration

2. Front bezel assembly with the door for hot-swap hard drives configuration on Intel® Server System P4000IP.



A. Security Lock

Figure 15. Front Closed Chassis View for Hot-swap Hard Drives Configuration

Both two pedestal front bezel are constructed of molded plastic and attaches to the front of the chassis with three clips on the right side and two snaps on the left. The snaps at the left attach behind the access cover, thereby preventing accidental removal of the bezel. The bezel can

only be removed by first removing the server access cover. This provides additional security to the hard drive and peripheral bay area.

For the front bezel assembly for fixed hard drives configuration, removing the bezel, there is an EMI shield covering the fixed hard drives bay area.

For the front bezel assembly for hot-swap hard drives configuration, the bezel includes a key-locking door that covers the drive cage area and allows access to hot swap drives when a hot swap drive cage is installed.

The peripheral bays are covered with plastic snap-in cosmetic pieces that must be removed to add peripherals to the system. Front panel buttons and lights are located above the peripheral bays.

2. System Power Sub-system

2.1 750-W Power Supply

This specification defines a 750W redundant power supply that supports server systems. This power supply has 2 outputs; 12V and 12V standby. The AC input is auto ranging and power factor corrected.

2.1.1 Mechanical Overview

The physical size of the power supply enclosure is 39/40mm x 73.5mm x 185mm. The power supply contains a single 40mm fan. The power supply has a card edge output that interfaces with a 2x25 card edge connector in the system. The AC plugs directly into the external face of the power supply. Refer to the following Figure 16. All dimensions are nominal.

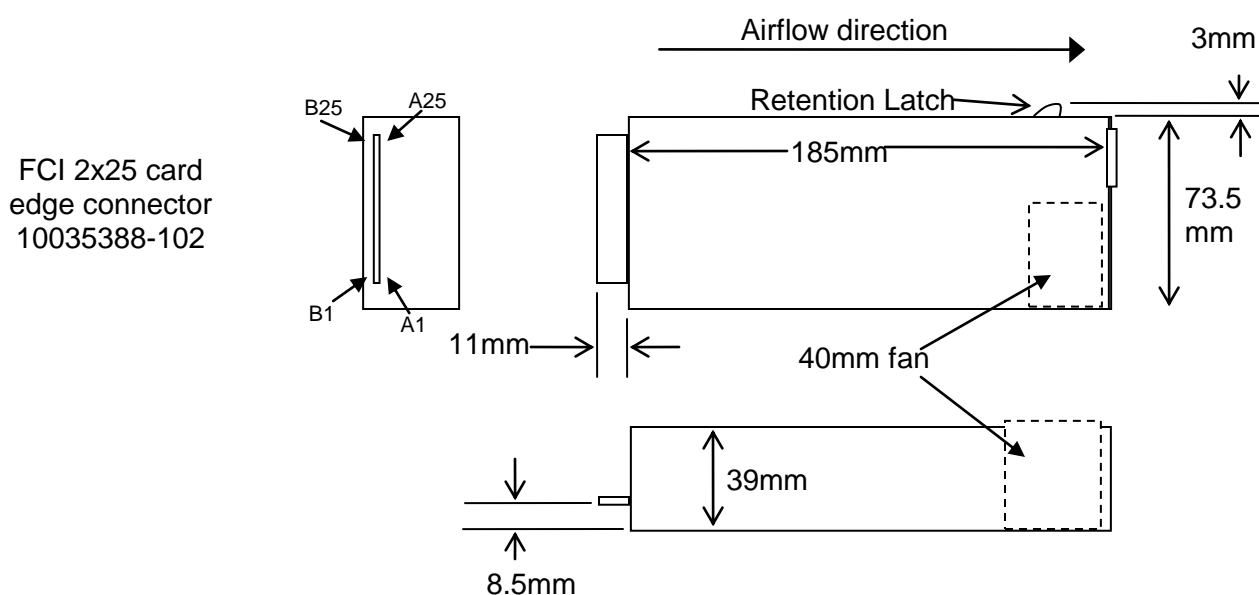

Figure 16. 750-W Power Supply Outline Drawing

2.1.1.1 DC Output Connector

The power supply uses a card edge output connection for power and signal that is compatible with a 2x25 Power Card Edge connector (equivalent to 2x25 pin configuration of the FCI power card connector 10035388-102LF).

Table 6. DC Output Connector

Pin	Name	Pin	Name
A1	GND	B1	GND
A2	GND	B2	GND
A3	GND	B3	GND
A4	GND	B4	GND
A5	GND	B5	GND

Pin	Name	Pin	Name
A6	GND	B6	GND
A7	GND	B7	GND
A8	GND	B8	GND
A9	GND	B9	GND
A10	+12V	B10	+12V
A11	+12V	B11	+12V
A12	+12V	B12	+12V
A13	+12V	B13	+12V
A14	+12V	B14	+12V
A15	+12V	B15	+12V
A16	+12V	B16	+12V
A17	+12V	B17	+12V
A18	+12V	B18	+12V
A19	PMBus SDA	B19	A0 (SMBus address)
A20	PMBus SCL	B20	A1 (SMBus address)
A21	PSON	B21	12V stby
A22	SMBAAlert#	B22	Cold Redundancy Bus
A23	Return Sense	B23	12V load share bus
A24	+12V remote Sense	B24	No Connect
A25	PWOK	B25	Compatibility Check pin

2.1.1.2 Handle Retention

The power supply has a handle to assist extraction. The module is able to be inserted and extracted without the assistance of tools. The power supply has a latch which retains the power supply into the system and prevents the power supply from being inserted or extracted from the system when the AC power cord is pulled into the power supply.

The handle protects the operator from any burn hazard.

2.1.1.3 LED Marking and Identification

The power supply uses a bi-color LED: Amber and Green. Below are table showing the LED states for each power supply operating state and the LED's wavelength characteristics. Refer to the Intel LED Wavelength and Intensity specification for more details.

Table 7. LED Characteristics

	Min λ Wavelength	Nominal λ Wavelength	Max λ Wavelength	Units
Green	562	565	568	nm
Amber	607	610	613	nm

Table 8. Power Supply LED Functionality

Power Supply Condition	LED State
Output ON and OK	GREEN
No AC power to all power supplies	OFF
AC present/Only 12VSB on (PS off) or PS in Cold redundant state	1Hz Blink GREEN
AC cord unplugged or AC power lost; with a second power supply in parallel still with AC input power.	AMBER
Power supply warning events where the power supply continues to operate; high temp, high power, high current, slow fan.	1Hz Blink Amber
Power supply critical event causing a shutdown; failure, OCP, OVP, Fan Fail	AMBER
Power supply FW updating	2Hz Blink GREEN

2.1.1.4 Temperature Requirements

The power supply operates within all specified limits over the T_{op} temperature range. All airflow passes through the power supply and not over the exterior surfaces of the power supply.

Table 9. Environmental Requirements

Item	Description	Min	Max	Units
$T_{op_sc_red}$	Operating temperature range; spreadcore redundant (60% load, 3000m, spreadcore system flow impedance2)	0	60	°C
$T_{op_sc_nr}$	Operating temperature range; spreadcore non-redundant (100% load, 3000m, spreadcore system flow impedance2)	0	50	°C
$T_{op_rackped_900}$	Operating temperature range; rack/pedestal 900m (100% load, 900m, rack/pedestal system flow impedance2)	0	45	°C
$T_{op_rackped_3000}$	Operating temperature range; rack/pedestal 3000m (100% load, 3000m, rack/pedestal system flow impedance2)	0	40	°C
Texit	Maximum exit air temperature		68	°C
T_{non-op}	Non-operating temperature range.	-40	70	°C
Altitude	Maximum operating altitude 3		3050	m

Notes:

- Under normal conditions, the exit air temperature shall be less than 65C. 68C is provided for absolute worst case conditions and is expected only to exist when the inlet ambient reaches 60C.
- $T_{op_rackped_900}$ condition only requires max altitude of 900m.

The power supply meets UL enclosure requirements for temperature rise limits. All sides of the power supply with exception to the air exhaust side are classified as “Handle, knobs, grips, etc. held for short periods of time only”.

2.1.2 AC Input Requirements

2.1.2.1 Power Factor

The power supply meets the power factor requirements stated in the *Energy Star® Program Requirements for Computer Servers*. These requirements are stated below.

Table 10. Power Factor Requirements for Computer Servers

Output power	10% load	20% load	50% load	100% load
Power factor	> 0.65	> 0.80	> 0.90	> 0.95

Tested at 230Vac, 50Hz and 60Hz and 115VAC, 60Hz

Tested according to *Generalized Internal Power Supply Efficiency Testing Protocol*, Rev 6.4.3.

This is posted at <http://efficientpowersupplies.epri.com/methods.asp>.

2.1.2.2 AC Inlet Connector

The AC input connector is an *IEC 320 C-14* power inlet. This inlet is rated for 10A/250VAC.

2.1.2.3 AC Input Voltage Specification

The power supply operates within all specified limits over the following input voltage range. Harmonic distortion of up to 10% of the rated line voltage does not cause the power supply to go out of specified limits. Application of an input voltage below 85VAC does not cause damage to the power supply, including a blown fuse.

Table 11. AC Input Voltage Range

PARAMETER	MIN	RATED	V _{MAX}	Start up VAC	Power Off VAC
Voltage (110)	90 V _{rms}	100-127 V _{rms}	140 V _{rms}	85VAC +/- 4VAC	74VAC +/- 5VAC
Voltage (220)	180 V _{rms}	200-240 V _{rms}	264 V _{rms}		
Frequency	47 Hz	50/60	63 Hz		

Notes:

1. Maximum input current at low input voltage range shall be measured at 90VAC, at max load.
2. Maximum input current at high input voltage range shall be measured at 180VAC, at max load.
3. This requirement is not to be used for determining agency input current markings.

2.1.2.4 AC Line Dropout/Holdup

An AC line dropout is defined to be when the AC input drops to 0VAC at any phase of the AC line for any length of time. During an AC dropout the power supply meets dynamic voltage regulation requirements. An AC line dropout of any duration does not cause tripping of control signals or protection circuits. If the AC dropout lasts longer than the holdup time the power supply recovers and meets all turn on requirements. The power supply meets the AC dropout requirement over rated AC voltages and frequencies. A dropout of the AC line for any duration does not cause damage to the power supply.

Table 12. AC Line Holdup Time

Loading	Holdup time
70%	12msec

2.1.2.5 AC Line 12VSBHoldup

The 12VSB output voltage stays in regulation under its full load (static or dynamic) during an AC dropout of **70ms min** (=12VSB holdup time) whether the power supply is in ON or OFF state (PSON asserted or de-asserted).

2.1.2.6 AC Line Fuse

The power supply has one line fused in the **single line fuse** on the line (Hot) wire of the AC input. The line fusing is acceptable for all safety agency requirements. The input is a slow blow type. AC inrush current does not cause the AC line fuse to blow under any conditions. All protection circuits in the power supply does not cause the AC fuse to blow unless a component in the power supply has failed. This includes DC output load short conditions.

2.1.2.7 AC Line Transient Specification

AC line transient conditions are defined as “sag” and “surge” conditions. “Sag” conditions are also commonly referred to as “brownout”, these conditions is defined as the AC line voltage dropping below nominal voltage conditions. “Surge” is defined to refer to conditions when the AC line voltage rises above nominal voltage.

The power supply meets the requirements under the following AC line sag and surge conditions.

Table 13. AC Line Sag Transient Performance

AC Line Sag (10sec interval between each sagging)				
Duration	Sag	Operating AC Voltage	Line Frequency	Performance Criteria
0 to 1/2 AC cycle	95%	Nominal AC Voltage ranges	50/60Hz	No loss of function or performance
> 1 AC cycle	>30%	Nominal AC Voltage ranges	50/60Hz	Loss of function acceptable, self recoverable

Table 14. AC Line Surge Transient Performance

AC Line Surge				
Duration	Surge	Operating AC Voltage	Line Frequency	Performance Criteria
Continuous	10%	Nominal AC Voltages	50/60Hz	No loss of function or performance
0 to ½ AC cycle	30%	Mid-point of nominal AC Voltages	50/60Hz	No loss of function or performance

2.1.2.8 Power Recovery

The power supply shall recover automatically after an AC power failure. AC power failure is defined to be any loss of AC power that exceeds the dropout criteria.

2.1.3 Efficiency

The following table provides the required minimum efficiency level at various loading conditions. These are provided at three different load levels; 100%, 50%, 20%, and 10%. Output shall be load according to the proportional loading method defined by 80 Plus in *Generalized Internal Power Supply Efficiency Testing Protocol*, Rev. 6.4.3. This is posted at <http://efficientpowersupplies.epri.com/methods.asp>.

Table 15. Silver Efficiency Requirement

Loading	100% of maximum	50% of maximum	20% of maximum	10% of maximum
Minimum Efficiency	91%	94%	90%	82%

The power supply passes with enough margins to make sure in production all power supplies meet these efficiency requirements.

2.1.4 DC Output Specification

2.1.4.1 Output Power/Currents

The following table defines the minimum power and current ratings. The power supply meets both static and dynamic voltage regulation requirements for all conditions.

Table 16. Minimum Load Ratings

Parameter	Min	Max.	Peak 2, 3	Unit
12V main	0.0	62.0	70.0	A
12Vstby 1	0.0	2.1	2.4	A

Notes:

- 12Vstby must provide 4.0A with two power supplies in parallel. The Fan may work when stby current >1.5A
- Length of time peak power can be supported is based on thermal sensor and assertion of the SMBAlert# signal. Minimum peak power duration shall be 20 seconds without asserting the SMBAlert# signal at maximum operating temperature.

2.1.4.2 Pmax Power support

The PSU should support 3msec peak power duration at a 50msec period; 5.7% duty cycle, Step loading from 730W to 1050W, Average power = 750W. Full AC input range; 100-127VAC/200-240VAC

2.1.4.3 Standby Output

The 12VSB output is present when an AC input greater than the power supply turn on voltage is applied.

2.1.4.4 Voltage Regulation

The power supply output voltages stay within the following voltage limits when operating at steady state and dynamic loading conditions. These limits include the peak-peak ripple/noise. These shall be measured at the output connectors.

Table 17. Voltage Regulation Limits

Parameter	Tolerance	Min	Nom	Max	Units
+12V	- 5%/+5%	+11.40	+12.00	+12.60	V _{rms}
+12V stby	- 5%/+5%	+11.40	+12.00	+12.60	V _{rms}

2.1.4.5 Dynamic Loading

The output voltages remains within limits specified for the step loading and capacitive loading specified in the table below. The load transient repetition rate is tested between 50Hz and 5kHz at duty cycles ranging from 10%-90%. The load transient repetition rate is only a test specification. The Δ step load may occur anywhere within the MIN load to the MAX load conditions.

Table 18. Transient Load Requirements

Output	Δ Step Load Size (See note 2)	Load Slew Rate	Test capacitive Load
+12VSB	1.0A	0.25 A/ μ sec	20 μ F
+12V	60% of max load	0.25 A/ μ sec	2000 μ F

Note:

For dynamic condition +12V min loading is 1A.

2.1.4.6 Capacitive Loading

The power supply is stable and meets all requirements with the following capacitive loading ranges.

Table 19. Capacitive Loading Conditions

Output	Min	Max	Units
+12VSB	20	3100	μ F
+12V	500	25000	μ F

2.1.4.7 Grounding

The output ground of the pins of the power supply provides the output power return path. The output connector ground pins are connected to the safety ground (power supply enclosure). This grounding is well designed to ensure passing the max allowed Common Mode Noise levels.

The power supply is provided with a reliable protective earth ground. All secondary circuits is connected to protective earth ground. Resistance of the ground returns to chassis does not exceed 1.0 m Ω . This path may be used to carry DC current.

2.1.4.8 Residual Voltage Immunity in Standby mode

The power supply is immune to any residual voltage placed on its outputs (Typically a leakage voltage through the system from standby output) up to 500mV. There is neither additional heat generated, nor stressing of any internal components with this voltage applied to any individual or all outputs simultaneously. It also does not trip the protection circuits during turn on.

The residual voltage at the power supply outputs for no load condition does not exceed 100mV when AC voltage is applied and the PSON# signal is de-asserted.

2.1.4.9 Common Mode Noise

The Common Mode noise on any output does not exceed 350mV pk-pk over the frequency band of 10Hz to 20MHz. The measurement is made across a 100Ω resistor between each of DC outputs, including ground at the DC power connector and chassis ground (power subsystem enclosure). The test set-up shall use a FET probe such as Tektronix model P6046 or equivalent.

2.1.4.10 Hot Swap Requirements

Hot swapping a power supply is the process of inserting and extracting a power supply from an operating power system. During this process the output voltages remains within the limits with the capacitive load specified. The hot swap test is conducted when the system is operating under static, dynamic, and zero loading conditions. The power supply uses a latching mechanism to prevent insertion and extraction of the power supply when the AC power cord is inserted into the power supply.

2.1.4.11 Forced Load Sharing

The +12V output will have active load sharing. The output will share within 10% at full load. The failure of a power supply does not affect the load sharing or output voltages of the other supplies still operating. The supplies are able to load share in parallel and operate in a hot-swap/redundant **1+1** configurations. The 12VSB output is not required to actively share current between power supplies (passive sharing). The 12VSB output of the power supplies are connected together in the system so that a failure or hot swap of a redundant power supply does not cause these outputs to go out of regulation in the system.

2.1.4.12 Ripple/Noise

The maximum allowed ripple/noise output of the power supply is defined in below Table. 41. This is measured over a bandwidth of 10Hz to 20MHz at the power supply output connectors. A 10μF tantalum capacitor in parallel with a 0.1μF ceramic capacitor is placed at the point of measurement.

Table 20. Ripples and Noise

+12V main	+12VSB
120mVp-p	120mVp-p

The test set-up shall be as shown below:

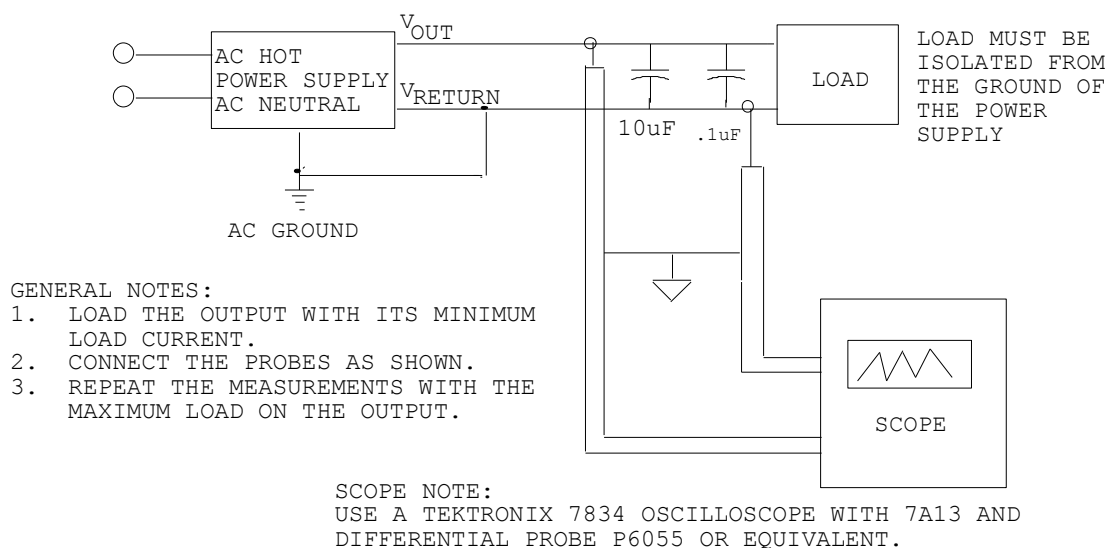

Figure 17. Differential Noise test setup

Note: When performing this test, the probe clips and capacitors should be located close to the load.

2.1.4.13 Timing Requirements

These are the timing requirements for the power supply operation. The output voltages must rise from 10% to within regulation limits (T_{vout_rise}) within 5 to 70ms. For 12VSB, it is allowed to rise from 1.0 to 25ms. **All outputs must rise monotonically.** Table below shows the timing requirements for the power supply being turned on and off by the AC input, with PSON held low and the PSON signal, with the AC input applied.

Table 21. Timing Requirements

Item	Description	Min	Max	Units
T_{vout_rise}	Output voltage rise time	5.0 *	70 *	ms
$T_{sb_on_delay}$	Delay from AC being applied to 12VSB being within regulation.		1500	ms
$T_{ac_on_delay}$	Delay from AC being applied to all output voltages being within regulation.		3000	ms
T_{vout_holdup}	Time 12V output voltage stay within regulation after loss of AC.	13		ms
T_{pwok_holdup}	Delay from loss of AC to de-assertion of PWOK	12		ms
$T_{pson_on_delay}$	Delay from PSON# active to output voltages within regulation limits.	5	400	ms
T_{pson_pwok}	Delay from PSON# deactivate to PWOK being de-asserted.		5	ms
T_{pwok_on}	Delay from output voltages within regulation limits to PWOK asserted at turn on.	100	500	ms
T_{pwok_off}	Delay from PWOK de-asserted to output voltages dropping out of regulation limits.	1		ms
T_{pwok_low}	Duration of PWOK being in the de-asserted state during an off/on cycle using AC or the PSON	100		ms

Item	Description	Min	Max	Units
	signal.			
T_{sb_vout}	Delay from 12VSB being in regulation to O/Ps being in regulation at AC turn on.	50	1000	ms
T_{12VSB_holdup}	Time the 12VSB output voltage stays within regulation after loss of AC.	70		ms

* The 12VSB output voltage rise time shall be from 1.0ms to 25ms.

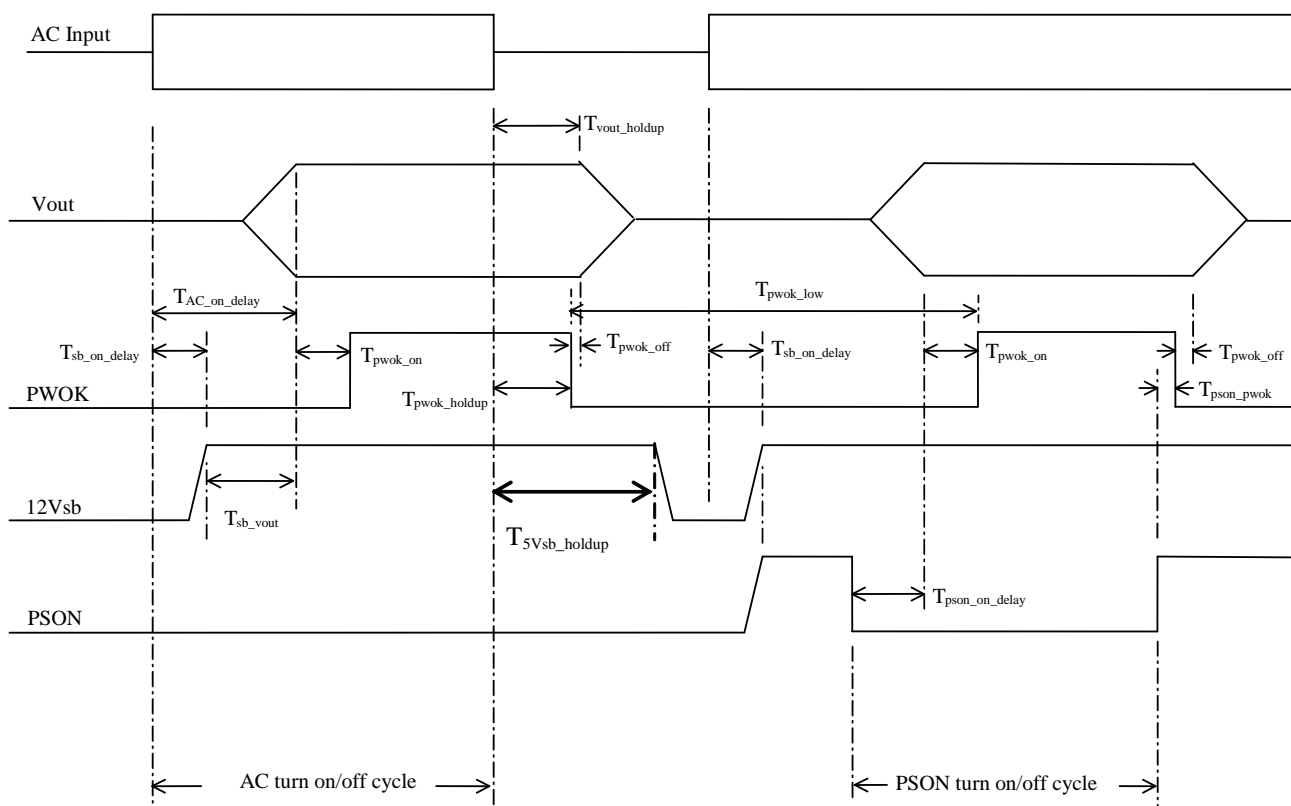

Figure 18. Turn On/Off Timing (Power Supply Signals)

2.1.5 Protection Circuits

Protection circuits inside the power supply causes only the power supply's main outputs to shutdown. If the power supply latches off due to a protection circuit tripping, an AC cycle OFF for 15sec and a PSON[#] cycle HIGH for 1sec is able to reset the power supply.

2.1.5.1 Current Limit (OCP)

The power supply has current limit to prevent the outputs from exceeding the values shown in table below. If the current limits are exceeded the power supply shuts down and latches off. The latch will be cleared by toggling the PSON[#] signal or by an AC power interruption. The power supply does not be damaged from repeated power cycling in this condition. 12VSB will be auto-recovered after removing OCP limit.

Table 22. Over Current Protection

Output VOLTAGE	Input voltage range	Over Current Limits
+12V	90 – 264VAC	72A min; 78A max
12VSB	90 – 264VAC	2.5A min; 3.5A max

2.1.5.2 Over Voltage Protection (OVP)

The power supply over voltage protection is locally sensed. The power supply shuts down and latches off after an over voltage condition occurs. This latch is cleared by toggling the PSON[#] signal or by an AC power interruption. The values are measured at the output of the power supply's connectors. The voltage does not exceed the maximum levels when measured at the power connectors of the power supply connector during any single point of fail. The voltage doesn't trip any lower than the minimum levels when measured at the power connector. 12VSB will be auto-recovered after removing OVP limit.

Table 23. Over Voltage Protection (OVP) Limits for 750W PSU

Output voltage	Min (v)	Max (v)
+12V	13.0	14.5
+12VSB	13.0	14.5

2.1.5.3 Over Temperature Protection (OTP)

The power supply will be protected against over temperature conditions caused by loss of fan cooling or excessive ambient temperature. In an OTP condition the PSU will shut down. When the power supply temperature drops to within specified limits, the power supply shall restore power automatically, while the 12VSB remains always on. The OTP circuit must have built in margin such that the power supply will not oscillate on and off due to temperature recovering condition. The OTP trip level shall have a minimum of 4°C of ambient temperature margin.

2.1.6 Control and Indicator Functions

The following sections define the input and output signals from the power supply. Signals that can be defined as low true use the following convention: Signal[#] = low true.

2.1.6.1 PSON[#] Input Signal

The PSON[#] signal is required to remotely turn on/off the power supply. PSON[#] is an active low signal that turns on the +12V power rail. When this signal is not pulled low by the system, or left open, the outputs (except the +12VSB) turn off. This signal is pulled to a standby voltage by a pull-up resistor internal to the power supply.

Table 24. PSON[#] Signal Characteristic

Signal Type	Accepts an open collector/drain input from the system. Pull-up to VSB located in power supply.	
PSON [#] = Low	ON	
PSON [#] = High or Open	OFF	
	MIN	MAX

Signal Type	Accepts an open collector/drain input from the system. Pull-up to VSB located in power supply.	
Logic level low (power supply ON)	0V	1.0V
Logic level high (power supply OFF)	2.0V	3.46V
Source current, $V_{pson} = \text{low}$		4mA
Power up delay: $T_{pson_on_delay}$	5msec	400msec
PWOK delay: T_{pson_pwok}		50msec

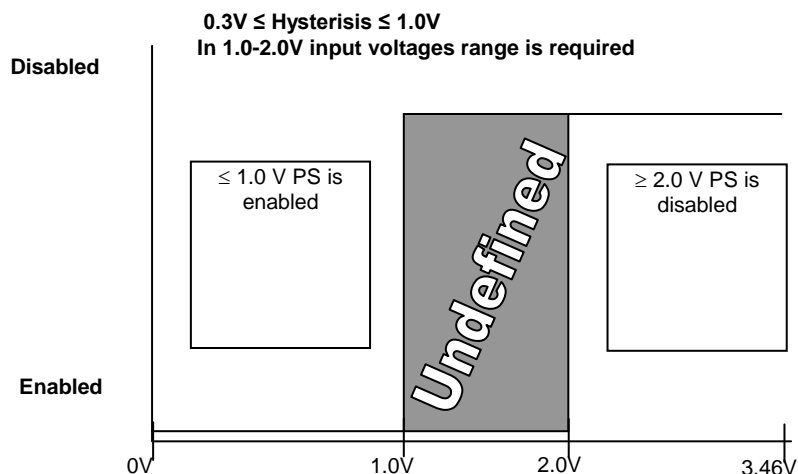

Figure 19. PSON# Required Signal Characteristic

2.1.6.2 PWOK (Power OK) Output Signal

PWOK is a power OK signal and will be pulled HIGH by the power supply to indicate that all the outputs are within the regulation limits of the power supply. When any output voltage falls below regulation limits or when AC power has been removed for a time sufficiently long so that power supply operation is no longer guaranteed, PWOK will be de-asserted to a LOW state. See Table 46 for a representation of the timing characteristics of PWOK. The start of the PWOK delay time shall be inhibited as long as any power supply output is in current limit.

Table 25. PWOK Signal Characteristics

Signal Type	Open collector/drain output from power supply. Pull-up to VSB located in the power supply.	
PWOK = High	Power OK	
PWOK = Low	Power Not OK	
	MIN	MAX
Logic level low voltage, $I_{sink}=400\mu\text{A}$	0V	0.4V
Logic level high voltage, $I_{source}=200\mu\text{A}$	2.4V	3.46V
Sink current, PWOK = low		400uA
Source current, PWOK = high		2mA
PWOK delay: T_{pwok_on}	100ms	1000ms

Signal Type	Open collector/drain output from power supply. Pull-up to VSB located in the power supply.	
PWOK rise and fall time		100µsec
Power down delay: T _{pwok_off}	1ms	200msec

A recommended implementation of the Power Ok circuits is shown below.

Note: The Power Ok circuits should be compatible with 5V pull up resistor (>10k) and 3.3V pull up resistor (>6.8k).

2.1.6.3 SMBAlert# Signal

This signal indicates that the power supply is experiencing a problem that the user should investigate. This shall be asserted due to Critical events or Warning events. The signal shall activate in the case of critical component temperature reached a warning threshold (see sec. 4.10), general failure, over-current, over-voltage, under-voltage, failed fan. This signal may also indicate the power supply is reaching its end of life or is operating in an environment exceeding the specified limits.

This signal is to be asserted in parallel with LED turning solid Amber or blink Amber.

Table 26. SMBAlert# Signal Characteristics

Signal Type (Active Low)	Open collector/drain output from power supply. Pull-up to VSB located in system.	
Alert# = High	OK	
Alert# = Low	Power Alert to system	
	MIN	MAX
Logic level low voltage, I _{sink} =4 mA	0 V	0.4 V
Logic level high voltage, I _{sink} =50 µA		3.46 V
Sink current, Alert# = low		4 mA
Sink current, Alert# = high		50 µA
Alert# rise and fall time		100 µs

2.1.7 Thermal CLST

The power supply shall assert the SMBAlert signal when a temperature sensor crosses a warning threshold. Refer to the *Intel® Common Hardware and Firmware Requirements for CRPS Power Supplier* for detailed requirements.

2.1.8 Power Supply Diagnostic “Black Box”

The power supply saves the latest PMBus data and other pertinent data into nonvolatile memory when a critical event shuts down the power supply. This data is accessible by the SMBus interface with an external source providing power to the 12Vstby output.

Refer to the *Intel® Common Hardware and Firmware Requirements for CRPS Power Supplier* for detailed requirements.

2.1.9 Firmware Uploader

The power supply has the capability to update its firmware from the PMBus interface while it is in standby mode. This FW can be updated when in the system and in standby mode and outside the system with power applied to the 12Vstby pins.

Refer to the *Intel® Common Hardware and Firmware Requirements for CRPS Power Supplier* for detailed requirements.

2.2 1200-W Power Supply

This specification defines a 1200W redundant power supply that supports server systems. The parameters of this power supply are defined in this specification. This specification defines a power supply with 2 outputs; 12V and 12V standby. The AC input shall be auto ranging and power factor corrected.

2.2.1 Mechanical Overview

The physical size of the power supply enclosure is 39/40mm x 73.5mm x 265mm. The power supply contains a single 40mm fan. The power supply has a card edge output that interfaces with a 2x25 card edge connector in the system. The AC plugs directly into the external face of the power supply. Refer to the following figure. All dimensions are nominal.

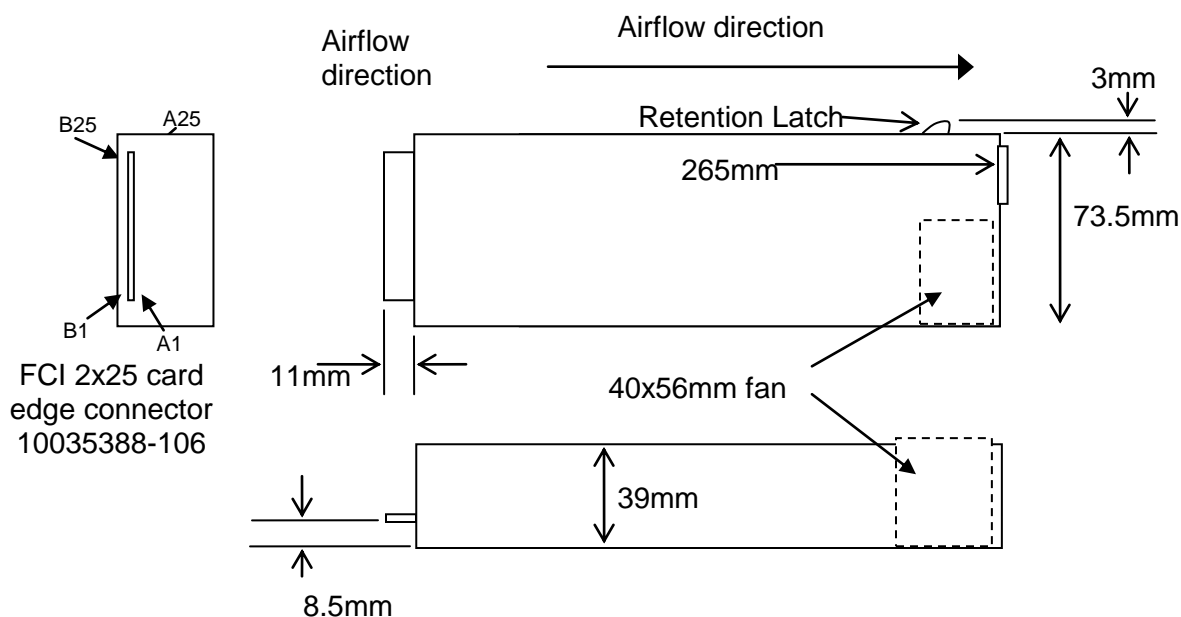

Figure 20. Power Supply Outline Drawing

2.2.1.1 DC Output Connector

The power supply shall use a card edge output connection for power and signal that is compatible with a 2x25 Power Card Edge connector (equivalent to 2x25 pin configuration of the FCI power card connector 10035388-102LF).

Table 27. DC Output Connector

Pin	Name	Pin	Name
A1	GND	B1	GND
A2	GND	B2	GND
A3	GND	B3	GND
A4	GND	B4	GND
A5	GND	B5	GND
A6	GND	B6	GND
A7	GND	B7	GND
A8	GND	B8	GND
A9	GND	B9	GND
A10	+12V	B10	+12V
A11	+12V	B11	+12V
A12	+12V	B12	+12V
A13	+12V	B13	+12V
A14	+12V	B14	+12V
A15	+12V	B15	+12V
A16	+12V	B16	+12V
A17	+12V	B17	+12V
A18	+12V	B18	+12V
A19	PMBus SDA	B19	A0 (SMBus address)
A20	PMBus SCL	B20	A1 (SMBus address)
A21	PSON	B21	12V stby
A22	SMBAAlert#	B22	Cold Redundancy Bus
A23	Return Sense	B23	12V load share bus
A24	+12V remote Sense	B24	No Connect
A25	PWOK	B25	Compatibility Check pin*

Note: Refer the specifications mentioned in the *Intel® Common Hardware and Firmware Requirements for CRPS Power Supplier*.

2.2.1.2 Handle Retention

The power supply shall have a handle to assist extraction. The module shall be able to be inserted and extracted without the assistance of tools. The power supply shall have a latch

which retains the power supply into the system and prevents the power supply from being inserted or extracted from the system when the AC power cord is pulled into the power supply.

The handle shall protect the operator from any burn hazard through the use of the Intel Corporation Industrial designed plastic handle or equivalent Intel approved material.

2.2.1.3 LED Marking and Identification

The power supply shall use a bi-color LED; Amber and Green. Below are table showing the LED states for each power supply operating state and the LED's wavelength characteristics. Refer to the *Intel® LED Wavelength and Intensity Specification* for more details.

Table 28. LED Characteristics

	Min λ Wavelength	Nominal λ Wavelength	Max λ Wavelength	Units
Green	562	565	568	nm
Amber	607	610	613	nm

Table 29. LED Status

Power Supply Condition	LED State
Output ON and OK	GREEN
No AC power to all power supplies	OFF
AC present/Only 12VSB on (PS off) or PS in Cold redundant state	1Hz Blink GREEN
AC cord unplugged or AC power lost; with a second power supply in parallel still with AC input power.	AMBER
Power supply warning events where the power supply continues to operate; high temp, high power, high current, slow fan.	1Hz Blink Amber
Power supply critical event causing a shutdown; failure, OCP, OVP, Fan Fail	AMBER
Power supply FW updating	2Hz Blink GREEN

2.2.1.4 Temperature Requirements

The power supply shall operate within all specified limits over the T_{op} temperature range. All airflow shall pass through the power supply and not over the exterior surfaces of the power supply.

Table 30. Environmental Requirements

Item	Description	MIN	MAX	UNITS
$T_{op_rackped_900}$	Operating temperature range; rack/pedestal 900m (100% load, 900m, rack/pedestal system flow impedance)	0	50	°C

Item	Description	MIN	MAX	UNITS
T _{op_rackped_3000}	Operating temperature range; rack/pedestal 3000m (100% load, 3000m, rack/pedestal system flow impedance)	0	45	°C
T _{exit}	Maximum exit air temperature		68 ¹	°C
T _{non-op}	Non-operating temperature range.	-40	70	°C
Altitude	Maximum operating altitude ³		3050	m

Notes:

- Under normal conditions, the exit air temperature shall be less than 65C. 68C is provided for absolute worst case conditions and is expected only to exist when the inlet ambient reaches 60C.
- T_{op_rackped_900} condition only requires max altitude of 900m.

The power supply must meet UL enclosure requirements for temperature rise limits. All sides of the power supply with exception to the air exhaust side must be classified as “Handle, knobs, grips, and so on, held for short periods of time only”.

2.2.2 AC Input Requirements

2.2.2.1 Power Factor

The power supply must meet the power factor requirements stated in the *Energy Star® Program Requirements for Computer Servers*. These requirements are stated below:

Output power	10% load	20% load	50% load	100% load
Power factor	> 0.80	> 0.90	> 0.90	> 0.95

Tested at 230Vac, 50Hz and 60Hz and 115VAC, 60Hz.

Tested according to *Generalized Internal Power Supply Efficiency Testing Protocol*, Rev 6.4.3.

This is posted at <http://efficientpowersupplies.epri.com/methods.asp>.

2.2.2.2 AC Inlet Connector

The AC input connector shall be an *IEC 320 C-14* power inlet. This inlet is rated for 10A/250VAC.

2.2.2.3 AC Input Voltage Specification

The power supply must operate within all specified limits over the following input voltage range. Harmonic distortion of up to 10% of the rated line voltage must not cause the power supply to go out of specified limits. Application of an input voltage below 85VAC shall not cause damage to the power supply, including a blown fuse.

Table 31. AC Input Voltage Range

Parameter	MIN	Rated	VMAX	Startup VAC	Power Off VAC

Voltage (110)	90 V _{rms}	100-127 V _{rms}	140 V _{rms}	85VAC +/- 4VAC	74VAC +/- 5VAC
Voltage (220)	180 V _{rms}	200-240 V _{rms}	264 V _{rms}		
Frequency	47 Hz	50/60	63 Hz		

Notes:

1. Maximum input current at low input voltage range shall be measured at 90VAC, at max load.
2. Maximum input current at high input voltage range shall be measured at 180VAC, at max load.
3. This requirement is not to be used for determining agency input current markings.

2.2.2.4 AC Line Dropout/Holdup

An AC line dropout is defined to be when the AC input drops to 0VAC at any phase of the AC line for any length of time. During an AC dropout the power supply must meet dynamic voltage regulation requirements. An AC line dropout of any duration shall not cause tripping of control signals or protection circuits. If the AC dropout lasts longer than the holdup time the power supply should recover and meet all turn on requirements. The power supply shall meet the AC dropout requirement over rated AC voltages and frequencies. A dropout of the AC line for any duration shall not cause damage to the power supply.

Loading	Holdup time
70%	10.6msec

2.2.2.5 AC Line 12VSB Holdup

The 12VSB output voltage should stay in regulation under its full load (static or dynamic) during an AC dropout of **70ms min** (=12VSB holdup time) whether the power supply is in ON or OFF state (PSON asserted or de-asserted).

2.2.2.6 AC Line Fuse

The power supply shall have one line fused in the **single line fuse** on the line (Hot) wire of the AC input. The line fusing shall be acceptable for all safety agency requirements. The input fuse shall be a slow blow type. AC inrush current shall not cause the AC line fuse to blow under any conditions. All protection circuits in the power supply shall not cause the AC fuse to blow unless a component in the power supply has failed. This includes DC output load short conditions.

2.2.2.7 AC Line Transient Specification

AC line transient conditions shall be defined as “sag” and “surge” conditions. “Sag” conditions are also commonly referred to as “brownout”, these conditions will be defined as the AC line voltage dropping below nominal voltage conditions. “Surge” will be defined to refer to conditions when the AC line voltage rises above nominal voltage.

The power supply shall meet the requirements under the following AC line sag and surge conditions.

Table 32. AC Line Sag Transient Performance

AC Line Sag (10sec interval between each sagging)				
Duration	Sag	Operating AC Voltage	Line Frequency	Performance Criteria
0 to 1/2 AC cycle	95%	Nominal AC Voltage ranges	50/60Hz	No loss of function or performance.
> 1 AC cycle	>30 %	Nominal AC Voltage ranges	50/60Hz	Loss of function acceptable, self-recoverable.

Table 33. AC Line Surge Transient Performance

AC Line Surge				
Duration	Surge	Operating AC Voltage	Line Frequency	Performance Criteria
Continuous	10%	Nominal AC Voltages	50/60Hz	No loss of function or performance
0 to 1/2 AC cycle	30%	Mid-point of nominal AC Voltages	50/60Hz	No loss of function or performance.

2.2.2.8 Power Recovery

The power supply shall recover automatically after an AC power failure. AC power failure is defined to be any loss of AC power that exceeds the dropout criteria.

2.2.3 Efficiency

The following table provides the required minimum efficiency level at various loading conditions. These are provided at three different load levels; 100%, 50%, 20%, and 10%. Output shall be load according to the proportional loading method defined by 80 Plus in *Generalized Internal Power Supply Efficiency Testing Protocol*, Rev 6.4.3. This is posted at <http://efficientpowersupplies.epri.com/methods.asp>

Table 34. Platinum Efficiency Requirement

Loading	100% of maximum	50% of maximum	20% of maximum	10% of maximum
Minimum Efficiency	91%	94%	90%	82%

The power supply must pass with enough margins to make sure in production all power supplies meet these efficiency requirements.

2.2.4 DC Output Specification**2.2.4.1 Output Power/Currents**

The following table defines the minimum power and current ratings. The power supply must meet both static and dynamic voltage regulation requirements for all conditions.

Table 35. Minimum Load Ratings

Parameter	Min	Max.	Peak 2, 3	Unit
12V main (200-240VAC)	0.0	100	133	A
12V main (100-127VAC)	0.0	83	110	A
12Vstby ¹	0.0	3	3.5	A

Notes:

1. 12Vstby must provide 6A with two power supplies in parallel. The power supply fan is allowed to run in standby mode for loads > 1.5A.
2. Length of time peak power can be supported is based on thermal sensor and assertion of the SMBAlert# signal.

2.2.4.2 Pmax Power support

The PSU should support 3msec peak power duration at a 50msec period; 5.7% duty cycle, Step loading from 1140W to 2200W, Average power = 1200W. High line only: 200-240VAC

2.2.4.3 Standby Output

The 12VSB output shall be present when an AC input greater than the power supply turn on voltage is applied.

2.2.4.4 Voltage Regulation

The power supply output voltages must stay within the following voltage limits when operating at steady state and dynamic loading conditions. These limits include the peak-peak ripple/noise. These shall be measured at the output connectors.

Table 36. Voltage Regulation Limits

Parameter	Tolerance	MIN	NOM	MAX	UNITS
+12V	- 5%/+5%	+11.40	+12.00	+12.60	V _{rms}
+12V stby	- 5%/+5%	+11.40	+12.00	+12.60	V _{rms}

2.2.4.5 Dynamic Loading

The output voltages shall remain within limits specified for the step loading and capacitive loading specified in the table below. The load transient repetition rate shall be tested between 50Hz and 5kHz at duty cycles ranging from 10%-90%. The load transient repetition rate is only a test specification. The Δ step load may occur anywhere within the MIN load to the MAX load conditions.

Table 37. Transient Load Requirements

Output	Δ Step Load Size (See note)	Load Slew Rate	Test capacitive Load
+12VSB	1.0A	0.25 A/ μ sec	20 μ F
+12V	60% of max load	0.25 A/ μ sec	2000 μ F

Note: For dynamic condition +12V min loading is 1A.

2.2.4.6 Capacitive Loading

The power supply shall be stable and meet all requirements with the following capacitive loading ranges.

Table 38. Capacitive Loading Conditions

Output	MIN	MAX	Units
+12VSB	20	3100	μ F
+12V	500	25000	μ F

2.2.4.7 Grounding

The output ground of the pins of the power supply provides the output power return path. The output connector ground pins shall be connected to the safety ground (power supply enclosure). This grounding should be well designed to ensure passing the max allowed Common Mode Noise levels.

2.2.4.8 Residual Voltage Immunity in Standby mode

The power supply should be immune to any residual voltage placed on its outputs (Typically a leakage voltage through the system from standby output) up to **500mV**. There shall be no additional heat generated, nor stressing of any internal components with this voltage applied to any individual or all outputs simultaneously. It also should not trip the protection circuits during turn on.

The residual voltage at the power supply outputs for no load condition shall not exceed **100mV** when AC voltage is applied and the PSON# signal is de-asserted.

2.2.4.9 Common Mode Noise

The Common Mode noise on any output shall not exceed **350mV pk-pk** over the frequency band of 10Hz to 20MHz.

1. The measurement shall be made across a 100 Ω resistor between each of DC outputs, including ground at the DC power connector and chassis ground (power subsystem enclosure).
2. The test set-up shall use a FET probe such as Tektronix model P6046 or equivalent.

2.2.4.10 Hot Swap Requirements

Hot swapping a power supply is the process of inserting and extracting a power supply from an operating power system. During this process the output voltages shall remain within the limits

with the capacitive load specified. The hot swap test must be conducted when the system is operating under static, dynamic, and zero loading conditions. The power supply shall use a latching mechanism to prevent insertion and extraction of the power supply when the AC power cord is inserted into the power supply.

2.2.4.11 Forced Load Sharing

The +12V output will have active load sharing. The output will share within 10% at full load. The failure of a power supply should not affect the load sharing or output voltages of the other supplies still operating. The supplies must be able to load share in parallel and operate in a hot-swap/redundant **1+1** configurations. The 12VSB output is not required to actively share current between power supplies (passive sharing). The 12VSB output of the power supplies are connected together in the system so that a failure or hot swap of a redundant power supply does not cause these outputs to go out of regulation in the system.

2.2.4.12 Ripple/Noise

The maximum allowed ripple/noise output of the power supply is defined in the table below. This is measured over a bandwidth of 10Hz to 20MHz at the power supply output connectors. A 10 μ F tantalum capacitor in parallel with a 0.1 μ F ceramic capacitor is placed at the point of measurement.

Table 39. Ripples and Noise

+12V main	+12VSB
120mVp-p	120mVp-p

The test set-up shall be as shown below:

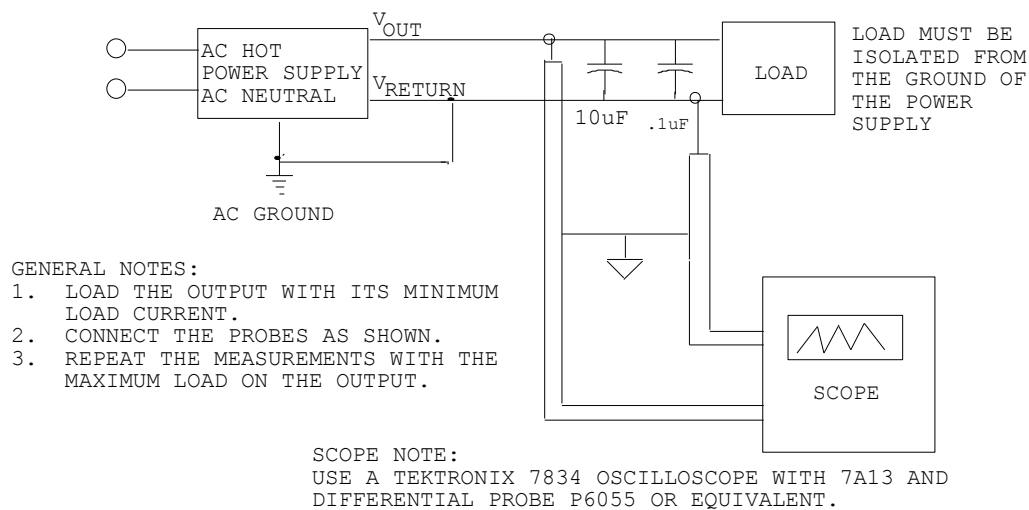

Figure 21. Differential Noise test setup

Note: When performing this test, the probe clips and capacitors should be located close to the load.

2.2.4.13 Timing Requirements

These are the timing requirements for the power supply operation. The output voltages must rise from 10% to within regulation limits (T_{vout_rise}) within 5 to 70ms. For 12VSB, it is allowed to rise from 1.0 to 25ms. **All outputs must rise monotonically.** Table below shows the timing requirements for the power supply being turned on and off by the AC input, with PSON held low and the PSON signal, with the AC input applied.

Table 40. Timing Requirements

Item	Description	MIN	MAX	UNITS
T_{vout_rise}	Output voltage rise time	5.0 *	70 *	ms
Tsb_on_delay	Delay from AC being applied to 12VSB being within regulation.		1500	ms
T ac_on_delay	Delay from AC being applied to all output voltages being within regulation.		3000	ms
Tvout_holdup	Time 12V output voltage stay within regulation after loss of AC.	13		ms
Tpwok_holdup	Delay from loss of AC to de-assertion of PWOK	10.6		ms
Tpson_on_delay	Delay from PSON# active to output voltages within regulation limits.	5	400	ms
Tpsn_pwok	Delay from PSON# deactivate to PWOK being de-asserted.		5	ms
Tpwok_on	Delay from output voltages within regulation limits to PWOK asserted at turn on.	100	500	ms
Tpwok_off	Delay from PWOK de-asserted to output voltages dropping out of regulation limits.	1		ms
Tpwok_low	Duration of PWOK being in the de-asserted state during an off/on cycle using AC or the PSON signal.	100		ms
Tsb_vout	Delay from 12VSB being in regulation to O/Ps being in regulation at AC turn on.	50	1000	ms
T12VSB_holdup	Time the 12VSB output voltage stays within regulation after loss of AC.	70		ms

* The 12VSB output voltage rise time shall be from 1.0ms to 25ms

2.2.5 Protection Circuits

Protection circuits inside the power supply shall cause only the power supply's main outputs to shut down. If the power supply latches off due to a protection circuit tripping, an AC cycle OFF for 15sec and a PSON# cycle HIGH for 1sec shall be able to reset the power supply.

2.2.5.1 Current Limit (OCP)

The power supply shall have current limit to prevent the outputs from exceeding the values shown in table below. If the current limits are exceeded the power supply shall shutdown and

latch off. The latch will be cleared by toggling the PSON[#] signal or by an AC power interruption. The power supply shall not be damaged from repeated power cycling in this condition. 12VSB will be auto-recovered after removing OCP limit.

Table 41. Over Current Protection

Output Voltage	Input voltage range	Over Current Limits
+12V	90 – 264VAC	140A min; 170A max
12VSB	90 – 264VAC	2.5A min; 3A max

2.2.5.2 Over Voltage Protection (OVP)

The power supply over voltage protection shall be locally sensed. The power supply shall shutdown and latch off after an over voltage condition occurs. This latch shall be cleared by toggling the PSON[#] signal or by an AC power interruption. The values are measured at the output of the power supply's connectors. The voltage shall never exceed the maximum levels when measured at the power connectors of the power supply connector during any single point of fail. The voltage shall never trip any lower than the minimum levels when measured at the power connector. 12VSB will be auto-recovered after removing OVP limit.

Table 42. Over Voltage Protection (OVP) Limits for 1200W PSU

Output Voltage	MIN (V)	MAX (V)
+12V	13.3	14.5
+12VSB	13.3	14.5

2.2.5.3 Over Temperature Protection (OTP)

The power supply will be protected against over temperature conditions caused by loss of fan cooling or excessive ambient temperature. In an OTP condition the PSU will shut down. When the power supply temperature drops to within specified limits, the power supply shall restore power automatically, while the 12VSB remains always on. The OTP circuit must have built in margin such that the power supply will not oscillate on and off due to temperature recovering condition. The OTP trip level shall have a minimum of 4°C of ambient temperature margin.

2.2.6 Control and Indicator Functions

The following sections define the input and output signals from the power supply. Signals that can be defined as low true use the following convention: *Signal[#]* = low true

2.2.6.1 PSON[#] Input Signal

The PSON[#] signal is required to remotely turn on/off the power supply. PSON[#] is an active low signal that turns on the +12V power rail. When this signal is not pulled low by the system, or left open, the outputs (except the +12VSB) turn off. This signal is pulled to a standby voltage by a pull-up resistor internal to the power supply.

Table 43. PSON[#] Signal Characteristic

Signal Type	Accepts an open collector/drain input from the system. Pull-up to VSB located in power supply.	
PSON# = Low	ON	
PSON# = High or Open	OFF	
	MIN	MAX
Logic level low (power supply ON)	0V	1.0V
Logic level high (power supply OFF)	2.0V	3.46V
Source current, Vpson = low		4mA
Power up delay: T _{pson_on_delay}	5msec	400msec
PWOK delay: T _{pson_pwok}		50msec

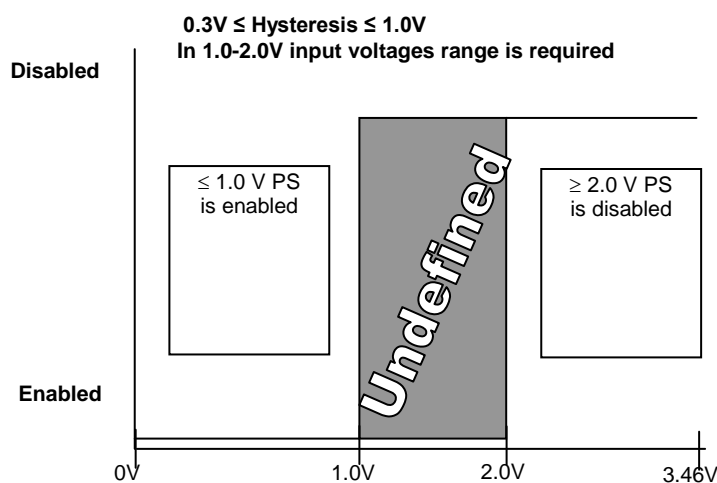

Figure 22. PSON# Required Signal Characteristic

2.2.6.2 PWOK (Power OK) Output Signal

PWOK is a power OK signal and will be pulled HIGH by the power supply to indicate that all the outputs are within the regulation limits of the power supply. When any output voltage falls below regulation limits or when AC power has been removed for a time sufficiently long so that power supply operation is no longer guaranteed, PWOK will be de-asserted to a LOW state. See the table below for a representation of the timing characteristics of PWOK. The start of the PWOK delay time shall inhibited as long as any power supply output is in current limit.

Table 44. PWOK Signal Characteristics

Signal Type	
-------------	--

PWOK = High	Power OK	
PWOK = Low	Power Not OK	
	MIN	MAX
Logic level low voltage, Isink=400uA	0V	0.4V
Logic level high voltage, Isource=200μA	2.4V	3.46V
Sink current, PWOK = low		400uA
Source current, PWOK = high		2mA
PWOK delay: T_{pwok_on}	100ms	1000ms
PWOK rise and fall time		100μsec
Power down delay: T_{pwok_off}	1ms	200msec

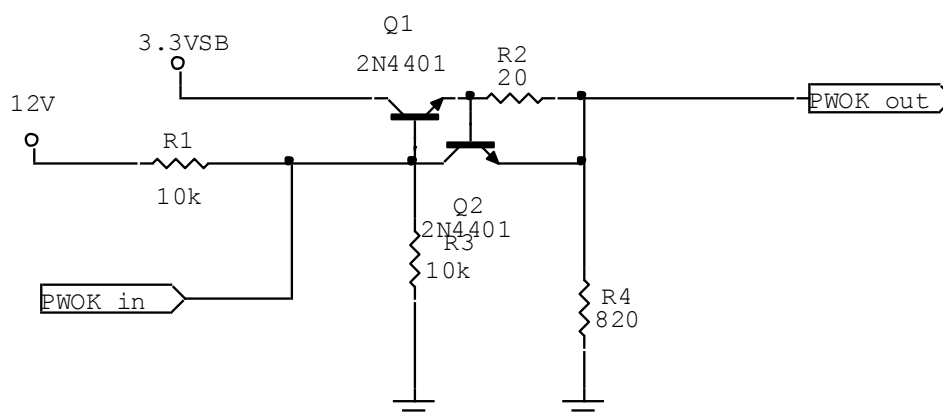

Figure 23. PWOK Circuit Requirement

2.2.6.3 SMBAlert# Signal

This signal indicates that the power supply is experiencing a problem that the user should investigate. This shall be asserted due to Critical events or Warning events. The signal shall activate in the case of critical component temperature reached a warning threshold (see sec. 4.10), general failure, over-current, over-voltage, under-voltage, failed fan. This signal may also indicate the power supply is reaching its end of life or is operating in an environment exceeding the specified limits.

This signal is to be asserted in parallel with LED turning solid Amber or blink Amber.

Table 45. SMBAlert# Signal Characteristics

Signal Type (Active Low)	Open collector/drain output from power supply. Pull-up to VSB located in system.	
Alert# = High	OK	
Alert# = Low	Power Alert to system	
	MIN	MAX
Logic level low voltage, Isink=4 mA	0 V	0.4 V
Logic level high voltage, Isink=50 μ A		3.46 V
Sink current, Alert# = low		4 mA
Sink current, Alert# = high		50 μ A
Alert# rise and fall time		100 μ s

2.2.7 Thermal CLST

The power supply shall assert the SMBAlert signal when a temperature sensor crosses a warning threshold. Refer to the *Intel® Common Hardware and Firmware Requirements for CRPS Power Supplier* for detailed requirements.

2.2.8 Power Supply Diagnostic “Black Box”

The power supply shall save the latest PMBus data and other pertinent data into nonvolatile memory when a critical event shuts down the power supply. This data shall be accessible from the SMBus interface with an external source providing power to the 12Vstby output.

Refer to *Intel® Common Hardware and Firmware Requirements for CRPS Power Supplier* for detailed requirements.

2.2.9 Firmware Update

The power supply shall have the capability to update its firmware from the PMBus interface while it is in standby mode. This FW can be updated when in the system and in standby mode and outside the system with power applied to the 12Vstby pins.

Refer to the *Intel® Common Hardware and Firmware Requirements for CRPS Power Supplier* for detailed requirements.

2.3 1600-W Power Supply

This specification defines a 1600W redundant power supply that supports server systems. The parameters of this power supply are defined in this specification. This specification defines a power supply with 2 outputs; 12V and 12V standby. The AC input shall be auto ranging and power factor corrected.

2.3.1 Mechanical Overview

The physical size of the power supply enclosure is 39/40mm x 73.5mm x 265mm. The power supply contains a single 40mm fan. The power supply has a card edge output that interfaces with a 2x25 card edge connector in the system. The AC plugs directly into the external face of the power supply. All dimensions are nominal.

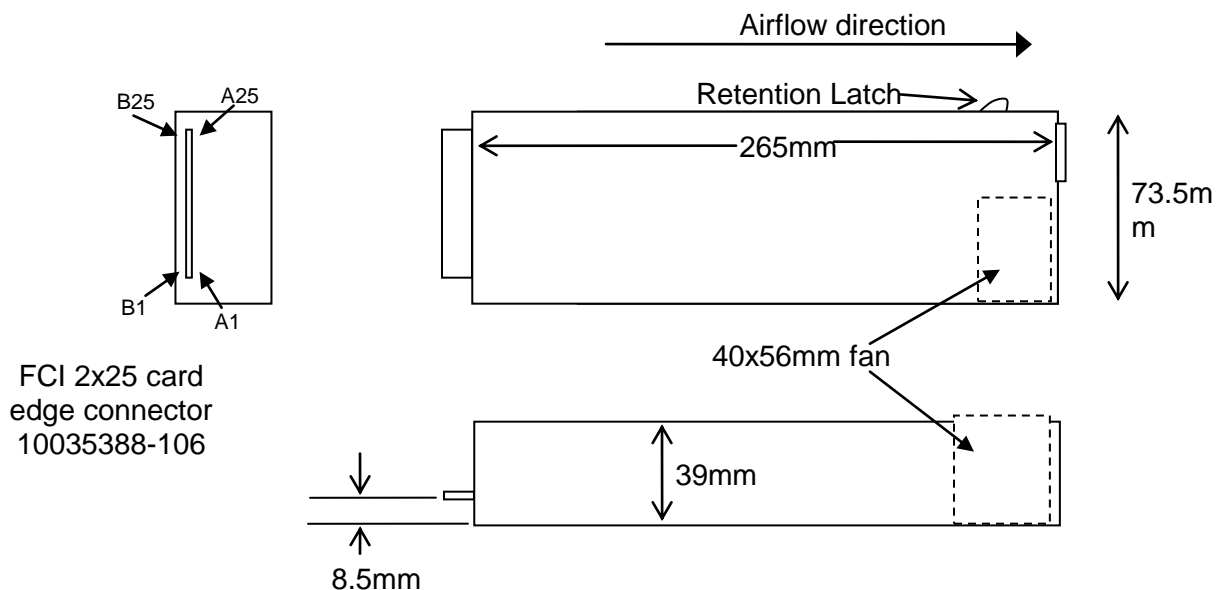

Figure 24. Power Supply Outline Drawing

2.3.1.1 DC Output Connector

The power supply shall use a card edge output connection for power and signal that is compatible with a 2x25 Power Card Edge connector (equivalent to 2x25 pin configuration of the FCI power card connector 10035388-102LF).

Table 46. DC Output Connector

Pin	Name	Pin	Name
A1	GND	B1	GND
A2	GND	B2	GND
A3	GND	B3	GND
A4	GND	B4	GND
A5	GND	B5	GND
A6	GND	B6	GND
A7	GND	B7	GND
A8	GND	B8	GND
A9	GND	B9	GND
A10	+12V	B10	+12V
A11	+12V	B11	+12V
A12	+12V	B12	+12V
A13	+12V	B13	+12V

Pin	Name	Pin	Name
A14	+12V	B14	+12V
A15	+12V	B15	+12V
A16	+12V	B16	+12V
A17	+12V	B17	+12V
A18	+12V	B18	+12V
A19	PMBus SDA ¹	B19	A0 (SMBus address) ¹
A20	PMBus SCL ¹	B20	A1 (SMBus address) ¹
A21	PSON	B21	12V stby
A22	SMBAAlert#	B22	Cold Redundancy Bus ¹
A23	Return Sense	B23	12V load share bus
A24	+12V remote Sense	B24	No Connect
A25	PWOK	B25	Compatibility Bus ¹

Note¹: Refer to the *CRPS Common Requirements specification*.

2.3.1.2 Handle Retention

The power supply shall have a handle to assist extraction. The module shall be able to be inserted and extracted without the assistance of tools. The power supply shall have a latch which retains the power supply into the system and prevents the power supply from being inserted or extracted from the system when the AC power cord is pulled into the power supply.

The handle shall protect the operator from any burn hazard through the use of the Intel Corporation Industrial designed plastic handle or equivalent Intel approved material.

2.3.1.3 LED Marking and Identification

The power supply shall use a bi-color LED; Amber and Green. The following tables show the LED states for each power supply operating state and the LED's wavelength characteristics. Refer to the *Intel® LED Wavelength and Intensity Specification* for more details.

Table 47. LED Characteristics

	Min Ad Wavelength	Nominal Ad Wavelength	Max Ad Wavelength	Units
Green	562	565	568	nm
Amber	607	610	613	nm

Table 48. LED Indicator States

Power Supply Condition	LED State

Power Supply Condition	LED State
Output ON and OK	Solid GREEN
No AC power to all power supplies	OFF
AC present/Only 12VSB on (PS off) or PS in Cold redundant state	1Hz Blink GREEN
AC cord unplugged; with a second power supply in parallel still with AC input power.	Solid AMBER
Power supply warning events where the power supply continues to operate; high temp, high power, high current, slow fan.	1Hz Blink AMBER
Power supply critical event causing a shutdown; failure, OCP, OVP, Fan Fail	Solid AMBER
Power supply in FW upload mode	2Hz Blink GREEN

2.3.1.4 Thermal Requirements

The power supply shall operate within all specified limits over the T_{op} temperature range. All airflow shall pass through the power supply and not over the exterior surfaces of the power supply.

Table 49 Environmental Requirements

ITEM	DESCRIPTION	MIN	MAX	UNITS
T_{op}	Operating temperature range; 900m	0	55	°C
T_{exit}	Maximum exit air temperature		68 ¹	°C
T_{non-op}	Non-operating temperature range.	-40	70	°C
Altitude	Maximum operating altitude ³		3000	m

The power supply must meet UL enclosure requirements for temperature rise limits. All sides of the power supply with exception to the air exhaust side must be classified as “Handle, knobs, grips, etc. held for short periods of time only”.

2.3.2 AC Input Requirements

2.3.2.1 Power Factor

The power supply must meet the power factor requirements stated in the *Energy Star® Program Requirements for Computer Servers*. These requirements are stated below.

Table 50 Environmental Requirements

Output power	10% load	20% load	50% load	100% load
Power factor	> 0.80	> 0.90	> 0.90	> 0.95

Tested at 230Vac, 50Hz and 60Hz and 115VAC, 60Hz

Tested according to *Generalized Internal Power Supply Efficiency Testing Protocol*, Rev 6.4.3.

This is posted at <http://efficientpowersupplies.epri.com/methods.asp>.

2.3.2.2 AC Inlet Connector

The AC input connector shall be an *IEC 320 C-14* power inlet. This inlet is rated for 10A/250VAC.

2.3.2.3 AC Input Voltage Specification

The power supply must operate within all specified limits over the following input voltage range. Harmonic distortion of up to 10% of the rated line voltage must not cause the power supply to go out of specified limits. Application of an input voltage below 85VAC shall not cause damage to the power supply, including a blown fuse.

Table 51 AC Input Voltage Range

PARAMETER	MIN	RATED	VMAX	Start up VAC	Power Off VAC
Voltage (110)	90 V _{rms}	100-127 V _{rms}	140 V _{rms}	85VAC +/- 4VAC	75VAC +/- 5VAC
Voltage (220)	180 V_{rms}	200-240 V _{rms}	264 V _{rms}		
Frequency	47 Hz	50/60	63 Hz		

Notes:

1. Maximum input current at low input voltage range shall be measured at 90VAC, at max load.
2. Maximum input current at high input voltage range shall be measured at 180VAC, at max load.
3. This requirement is not to be used for determining agency input current markings.

2.3.2.4 AC Line Dropout/Holdup

An AC line dropout is defined to be when the AC input drops to 0VAC at any phase of the AC line for any length of time. During an AC dropout the power supply must meet dynamic voltage regulation requirements. An AC line dropout of any duration shall not cause tripping of control signals or protection circuits. If the AC dropout lasts longer than the hold up time the power supply should recover and meet all turn on requirements. The power supply shall meet the AC dropout requirement over rated AC voltages and frequencies. A dropout of the AC line for any duration shall not cause damage to the power supply.

Table 52. AC Line Holdup Time

Loading	Holdup time
75%	10msec

2.3.2.5 AC Line 12VSB Holdup

The 12VSB output voltage should stay in regulation under its full load (static or dynamic) during an AC dropout of **70ms min** (=12VSB holdup time) whether the power supply is in ON or OFF state (PSON asserted or de-asserted).

2.3.2.6 AC Line Fuse

The power supply shall have one line fused in the **single line fuse** on the line (Hot) wire of the AC input. The line fusing shall be acceptable for all safety agency requirements. The input fuse shall be a slow blow type. AC inrush current shall not cause the AC line fuse to blow under any

conditions. All protection circuits in the power supply shall not cause the AC fuse to blow unless a component in the power supply has failed. This includes DC output load short conditions.

2.3.2.7 AC Line Transient Specification

AC line transient conditions shall be defined as “sag” and “surge” conditions. “Sag” conditions are also commonly referred to as “brownout”, these conditions will be defined as the AC line voltage dropping below nominal voltage conditions. “Surge” will be defined to refer to conditions when the AC line voltage rises above nominal voltage. The power supply shall meet the requirements under the following AC line sag and surge conditions.

Table 53 AC Line Sag Transient Performance

AC Line Sag (10sec interval between each sagging)				
Duration	Sag	Operating AC Voltage	Line Frequency	Performance Criteria
0 to 1/2 AC cycle	95%	Nominal AC Voltage ranges	50/60Hz	No loss of function or performance
> 1 AC cycle	>30 %	Nominal AC Voltage ranges	50/60Hz	Loss of function acceptable, self recoverable

Table 54 AC Line Surge Transient Performance

AC Line Surge				
Duration	Surge	Operating AC Voltage	Line Frequency	Performance Criteria
Continuous	10%	Nominal AC Voltages	50/60Hz	No loss of function or performance
0 to ½ AC cycle	30%	Mid-point of nominal AC Voltages	50/60Hz	No loss of function or performance

2.3.2.8 Power Recovery

The power supply shall recover automatically after an AC power failure. AC power failure is defined to be any loss of AC power that exceeds the dropout criteria.

2.3.3 Efficiency

The following table provides the required minimum efficiency level at various loading conditions. These are provided at three different load levels; 100%, 50%, 20%, and 10%. Output shall be load according to the proportional loading method defined by 80 Plus in *Generalized Internal Power Supply Efficiency Testing Protocol*, Rev. 6.4.3. This is posted at: <http://efficientpowersupplies.epri.com/methods.asp>.

Table 55 Platinum Efficiency Requirement

Loading	100% of maximum	50% of maximum	20% of maximum	10% of maximum
Minimum Efficiency	91%	94%	90%	82%

The power supply must pass with enough margin to make sure in production all power supplies meet these efficiency requirements.

2.3.4 DC Output Specification

2.3.4.1 Output Power/Currents

The following tables define the minimum power and current ratings. The power supply must meet both static and dynamic voltage regulation requirements for all conditions.

Table 56 Minimum Load Ratings

Parameter	Min	Max.	Peak 2, 3	Unit
12V main (200-240VAC)	0.0	133	175	A
12V main (100-127VAC)	0.0	83	110	A
12Vstby 1	0.0	3.5	4.0	A

Notes:

- 12Vstby must be able to provide 4.0A peak load with single power supply. The power supply fan is allowed to run in standby mode for loads > 1.5A.
- Peak combined power for all outputs shall not exceed 2100W.
- Length of time peak power can be supported is based on thermal sensor and assertion of the SMBAlert# signal. Minimum peak power duration shall be 20 seconds without asserting the SMBAlert# signal.

2.3.4.2 Standby Output

The 12VSB output shall be present when an AC input greater than the power supply turn on voltage is applied.

2.3.4.3 Voltage Regulation

The power supply output voltages must stay within the following voltage limits when operating at steady state and dynamic loading conditions. These limits include the peak-peak ripple/noise. These shall be measured at the output connectors.

Table 57 Voltage Regulation Limits

PARAMETER	TOLERANCE	MIN	NOM	MAX	UNITS
+12V	- 5%/+5%	+11.40	+12.00	+12.60	V _{rms}
+12V stby	- 5%/+5%	+11.40	+12.00	+12.60	V _{rms}

2.3.4.4 Dynamic Loading

The output voltages shall remain within limits specified for the step loading and capacitive loading specified in the table below. The load transient repetition rate shall be tested between 50Hz and 5kHz at duty cycles ranging from 10%-90%. The load transient repetition rate is only a test specification. The Δ step load may occur anywhere within the MIN load to the MAX load conditions.

Table 58. Transient Load Requirements

Output	Δ Step Load Size	Load Slew Rate	Test capacitive Load
--------	-------------------------	----------------	----------------------

	(See note 2)		
+12VSB	1.0A	0.25 A/ μ sec	20 μ F
+12V	60% of max load	0.25 A/ μ sec	2000 μ F

Note: For dynamic condition +12V min loading is 1A.

2.3.4.5 Capacitive Loading

The power supply shall be stable and meet all requirements with the following capacitive loading ranges.

Table 59. Capacitive Loading Conditions

Output	MIN	MAX	Units
+12VSB	20	3100	μ F
+12V	500	25000	μ F

2.3.4.6 Grounding

The output ground of the pins of the power supply provides the output power return path. The output connector ground pins shall be connected to the safety ground (power supply enclosure). This grounding should be well designed to ensure passing the max allowed Common Mode Noise levels.

The power supply shall be provided with a reliable protective earth ground. All secondary circuits shall be connected to protective earth ground. Resistance of the ground returns to chassis shall not exceed 1.0 m Ω . This path may be used to carry DC current.

2.3.4.7 Residual Voltage Immunity in Standby mode

The power supply should be immune to any residual voltage placed on its outputs (Typically a leakage voltage through the system from standby output) up to **500mV**. There shall be no additional heat generated, nor stressing of any internal components with this voltage applied to any individual or all outputs simultaneously. It also should not trip the protection circuits during turn on.

The residual voltage at the power supply outputs for no load condition shall not exceed **100mV** when AC voltage is applied and the PSON# signal is de-asserted.

2.3.4.8 Common Mode Noise

The Common Mode noise on any output shall not exceed **350mV pk-pk** over the frequency band of 10Hz to 20MHz.

1. The measurement shall be made across a 100 Ω resistor between each of DC outputs, including ground at the DC power connector and chassis ground (power subsystem enclosure).
2. The test set-up shall use a FET probe such as Tektronix model P6046 or equivalent.

2.3.4.9 Hot Swap Requirements

Hot swapping a power supply is the process of inserting and extracting a power supply from an operating power system. During this process the output voltages shall remain within the limits with the capacitive load specified. The hot swap test must be conducted when the system is operating under static, dynamic, and zero loading conditions. The power supply shall use a

latching mechanism to prevent insertion and extraction of the power supply when the AC power cord is inserted into the power supply.

2.3.4.10 Forced Load Sharing

The +12V output will have active load sharing. The output will share within 10% at full load. The failure of a power supply should not affect the load sharing or output voltages of the other supplies still operating. The supplies must be able to load share in parallel and operate in a hot-swap/redundant **1+1** configurations. The 12VSB output is not required to actively share current between power supplies (passive sharing). The 12VSB output of the power supplies are connected together in the system so that a failure or hot swap of a redundant power supply does not cause these outputs to go out of regulation in the system.

2.3.4.11 Ripple/Noise

The maximum allowed ripple/noise output of the power supply is defined in Table below. This is measured over a bandwidth of 10Hz to 20MHz at the power supply output connectors. A 10 μ F tantalum capacitor in parallel with a 0.1 μ F ceramic capacitor is placed at the point of measurement.

Table 60. Ripples and Noise

+12V main	+12VSB
120mVp-p	120mVp-p

The test set-up shall be as shown below.

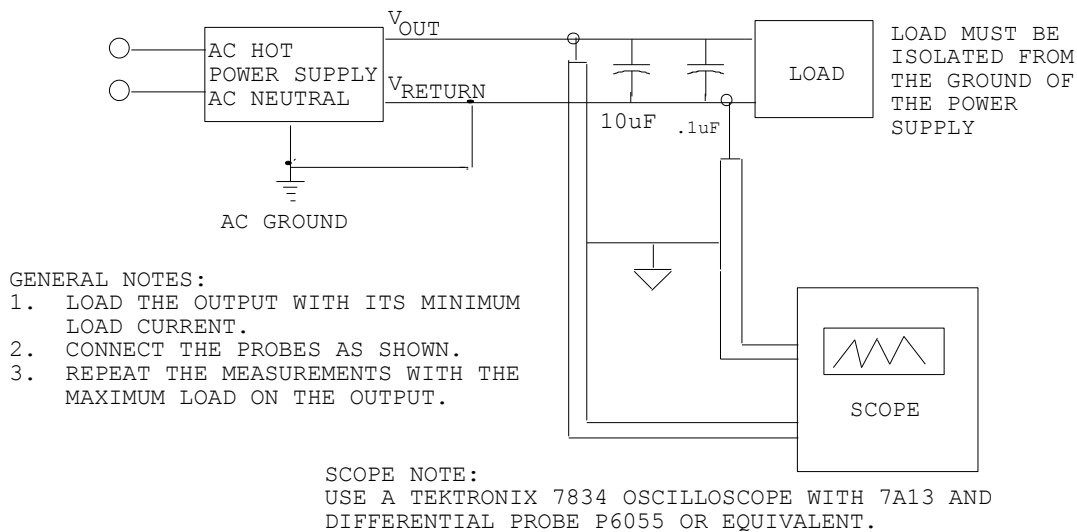

Figure 25 Differential Noise test setup

Note: When performing this test, the probe clips and capacitors should be located close to the load.

2.3.4.12 Timing Requirements

These are the timing requirements for the power supply operation. The output voltages must rise from 10% to within regulation limits (T_{vout_rise}) within 5 to 70ms. For 12VSB, it is allowed to rise from 1.0 to 25ms. **All outputs must rise monotonically.** Table below shows the timing requirements for the power supply being turned on and off by the AC input, with PSON held low and the PSON signal, with the AC input applied.

Table 61. Timing Requirements

Item	Description	MIN	MAX	UNITS
T_{vout_rise}	Output voltage rise time	5.0 *	70 *	ms
Tsb_on_delay	Delay from AC being applied to 12VSB being within regulation.		1500	ms
Tac_on_delay	Delay from AC being applied to all output voltages being within regulation.		3000	ms
Tvout_holdup	Time 12V output voltage stay within regulation after loss of AC.	11		ms
Tpwok_holdup	Delay from loss of AC to de-assertion of PWOK	10		ms
Tpson_on_delay	Delay from PSON# active to output voltages within regulation limits.	5	400	ms
Tpson_pwok	Delay from PSON# deactivate to PWOK being de-asserted.		5	ms
Tpwok_on	Delay from output voltages within regulation limits to PWOK asserted at turn on.	100	500	ms
Tpwok_off	Delay from PWOK de-asserted to output voltages dropping out of regulation limits.	1		ms
Tpwok_low	Duration of PWOK being in the de-asserted state during an off/on cycle using AC or the PSON signal.	100		ms
Tsb_vout	Delay from 12VSB being in regulation to O/Ps being in regulation at AC turn on.	50	1000	ms
T12VSB_holdup	Time the 12VSB output voltage stays within regulation after loss of AC.	70		ms

* The 12VSB output voltage rise time shall be from 1.0ms to 25ms.

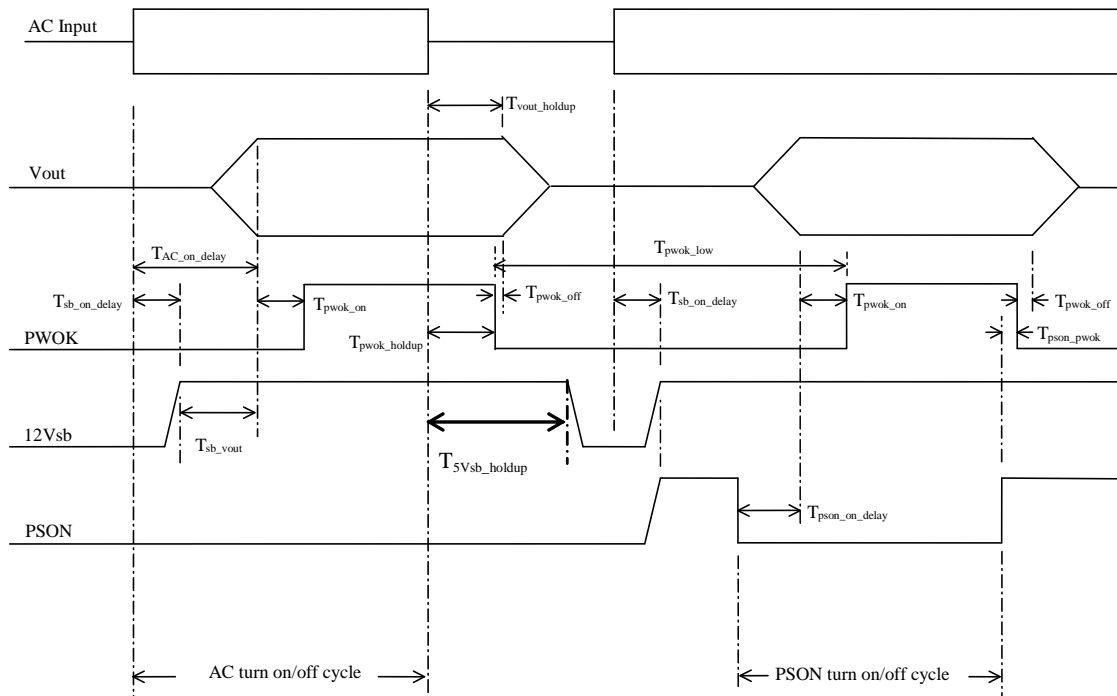

Figure 26 Turn On/Off Timing (Power Supply Signals)

2.3.5 Protection Circuits

Protection circuits inside the power supply shall cause only the power supply’s main outputs to shutdown. If the power supply latches off due to a protection circuit tripping, an AC cycle OFF for 15sec and a PSON# cycle HIGH for 1sec shall be able to reset the power supply.

2.3.5.1 Current Limit (OCP)

The power supply shall have current limit to prevent the outputs from exceeding the values shown in table below. If the current limits are exceeded the power supply shall shutdown and latch off. The latch will be cleared by toggling the PSON# signal or by an AC power interruption. The power supply shall not be damaged from repeated power cycling in this condition. 12VSB will be auto-recovered after removing OCP limit.

Table 62 Over Current Protection

Output VOLTAGE	Input voltage range	OVER CURRENT LIMITs
+12V	90 – 264VAC	180A min; 200A max
12VSB	90 – 264VAC	4A min; 5A max

2.3.5.2 Over Voltage Protection (OVP)

The power supply over voltage protection shall be locally sensed. The power supply shall shutdown and latch off after an over voltage condition occurs. This latch shall be cleared by toggling the PSON# signal or by an AC power interruption. The values are measured at the

output of the power supply's connectors. The voltage shall never exceed the maximum levels when measured at the power connectors of the power supply connector during any single point of fail. The voltage shall never trip any lower than the minimum levels when measured at the power connector. 12VSB will be auto-recovered after removing OVP limit.

Table 63. Over Voltage Protection (OVP) Limits for 1600W PSU

Output Voltage	MIN (V)	MAX (V)
+12V	13.3	14.5
+12VSB	13.3	14.5

2.3.5.3 Over Temperature Protection (OTP)

The power supply will be protected against over temperature conditions caused by loss of fan cooling or excessive ambient temperature. In an OTP condition the PSU will shutdown. When the power supply temperature drops to within specified limits, the power supply shall restore power automatically, while the 12VSB remains always on. The OTP circuit must have built in margin such that the power supply will not oscillate on and off due to temperature recovering condition. The OTP trip level shall have a minimum of 4°C of ambient temperature margin.

2.3.6 Control and Indicator Functions

The following sections define the input and output signals from the power supply. Signals that can be defined as low true use the following convention: Signal# = low true

2.3.6.1 PSON# Input Signal

The PSON# signal is required to remotely turn on/off the power supply. PSON# is an active low signal that turns on the +12V power rail. When this signal is not pulled low by the system, or left open, the outputs (except the +12VSB) turn off. This signal is pulled to a standby voltage by a pull-up resistor internal to the power supply.

Table 64 PSON# Signal Characteristic

Signal Type	Accepts an open collector/drain input from the system. Pull-up to VSB located in power supply.	
PSON# = Low	ON	
PSON# = High or Open	OFF	
	MIN	MAX
Logic level low (power supply ON)	0V	1.0V
Logic level high (power supply OFF)	2.0V	5.25V
Source current, $V_{pson} = \text{low}$		4mA
Power up delay: $T_{pson_on_delay}$	5msec	400msec
PWOK delay: T_{pson_pwok}		50msec

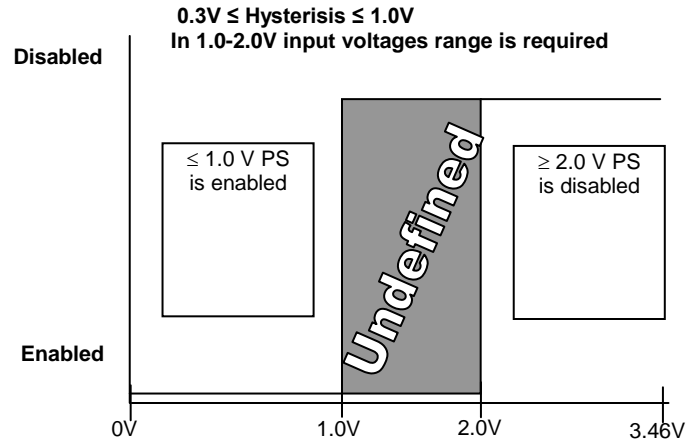

Figure 27. PSON# Required Signal Characteristic

2.3.6.2 PWOK (Power OK) Output Signal

PWOK is a power OK signal and will be pulled HIGH by the power supply to indicate that all the outputs are within the regulation limits of the power supply. When any output voltage falls below regulation limits or when AC power has been removed for a time sufficiently long so that power supply operation is no longer guaranteed, PWOK will be de-asserted to a LOW state. See [the following table](#) for a representation of the timing characteristics of PWOK. The start of the PWOK delay time shall inhibited as long as any power supply output is in current limit.

Table 65 PWOK Signal Characteristics

Signal Type		
PWOK = High	Power OK	
PWOK = Low	Power Not OK	
	MIN	MAX
Logic level low voltage, Isink=400uA	0V	0.4V
Logic level high voltage, Isource=200µA	2.4V	3.46V
Sink current, PWOK = low		400uA
Source current, PWOK = high		2mA
PWOK delay: T _{pwok_on}	100ms	1000ms
PWOK rise and fall time		100µsec
Power down delay: T _{pwok_off}	1ms	200msec

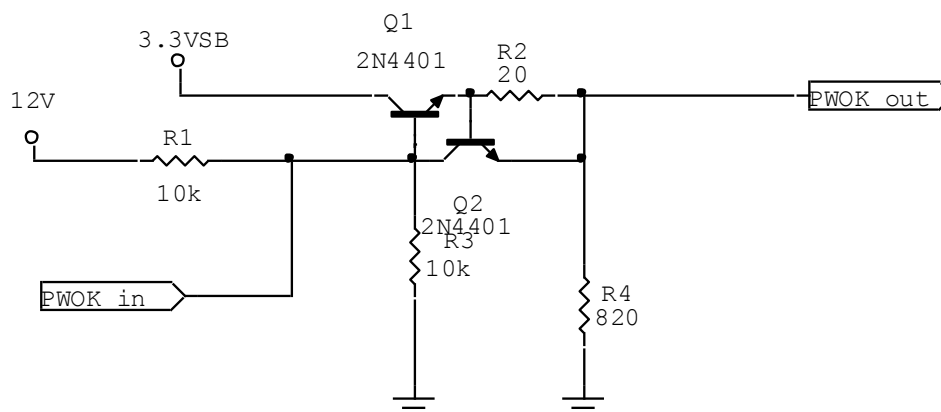

Figure 28. PWOK Circuit Requirement

2.3.6.3 SMBAlert# Signal

This signal indicates that the power supply is experiencing a problem that the user should investigate. This shall be asserted due to Critical events or Warning events. The signal shall activate in the case of critical component temperature reaching a warning threshold, general failure, over-current, over-voltage, under-voltage, failed fan. This signal may also indicate the power supply is reaching its end of life or is operating in an environment exceeding the specified limits.

This signal is to be asserted in parallel with LED turning solid Amber or blink Amber.

Table 66 SMBAlert# Signal Characteristics

Signal Type (Active Low)	Open collector/drain output from power supply. Pull-up to VSB located in system.	
Alert# = High	OK	
Alert# = Low	Power Alert to system	
	MIN	MAX
Logic level low voltage, $I_{\text{sink}}=4 \text{ mA}$	0 V	0.4 V
Logic level high voltage, $I_{\text{sink}}=50 \mu\text{A}$		3.46 V
Sink current, Alert# = low		4 mA
Sink current, Alert# = high		50 μA
Alert# rise and fall time		100 μs

2.3.7 Thermal CLST

The power supply shall assert the SMBAlert signal when a temperature sensor crosses a warning threshold.

Refer to the *CRPS Common Requirements Specification* for detailed requirements.

2.3.8 Power Supply Diagnostic “Black Box”

The power supply shall save the latest PMBus data and other pertinent data into nonvolatile memory when a critical event shuts down the power supply. This data shall be accessible from the SMBus interface with an external source providing power to the 12Vstby output.

Refer to the *CRPS Common Requirements Specification* for detailed requirements.

2.3.9 Firmware Update

The power supply shall have the capability to update its firmware from the PMBus interface while it is in standby mode. This FW can be updated when in the system and in standby mode and outside the system with power applied to the 12Vstby pins.

Refer to the *CRPS Common Requirements Specification* for detailed requirements.

2.4 Higer Current Power Common Redundant Power Distribution Board (PDB)

The Power Distribution Board (PDB) for Intel® Server System P4000IP and Intel® Workstation System P4000CR supports the Common Redundant power supply in a 1+1 redundant configuration. The PDB is designed to plug directly to the output connector of the PS and it contains 3 DC/DC power converters to produce other required voltages: +3.3VDC, +5VDC and 5V standby along with additional over current protection circuit for the 12V rails.

This power distribution board is intended to be used in the Intel® Server System P4000IP and Intel® Workstation System P4000CR with various common redundant power supplies; 750W, 1200W, 1600W.

2.4.1 Mechanical Overview

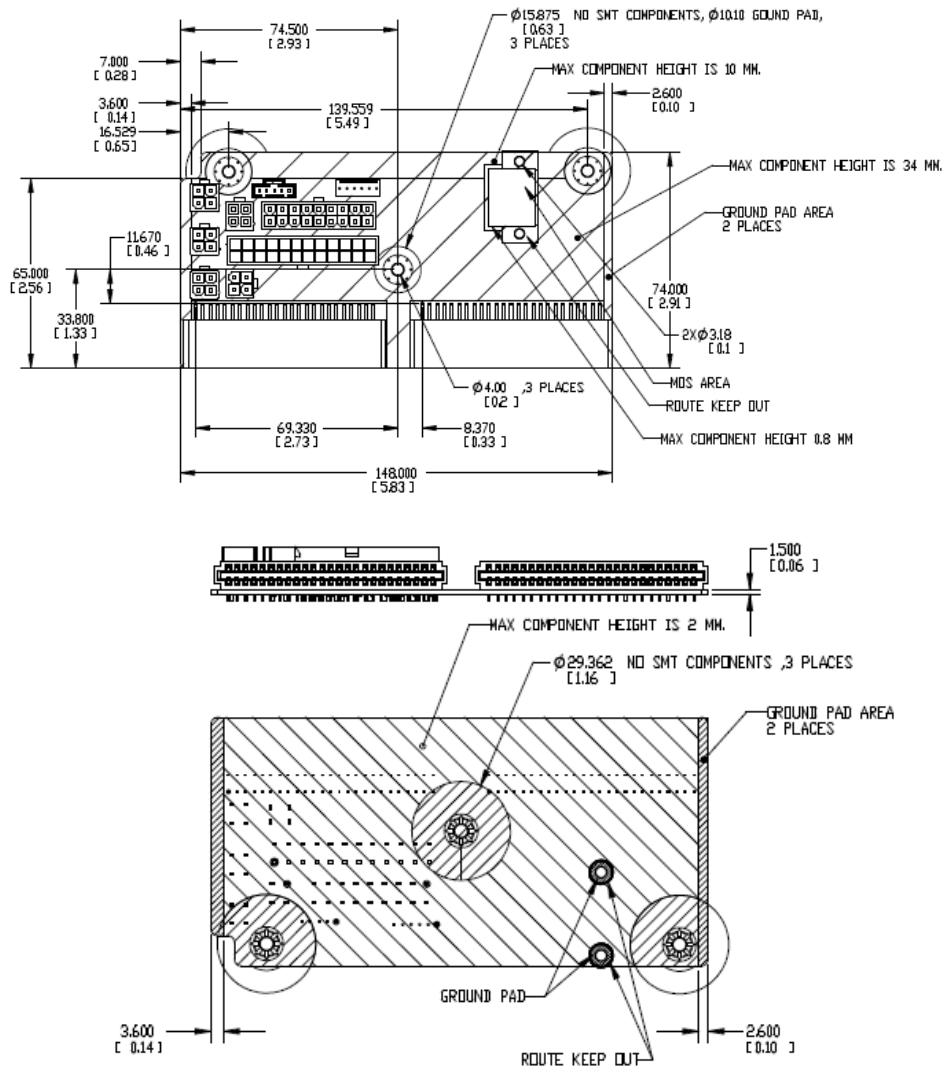

NOTE: UNLESS OTHERWISE SPECIFIED, MAX COMPONENT HEIGHT IS 34 MM

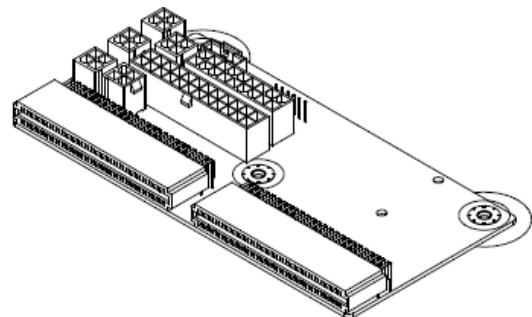

Figure 29. Outline Drawing

2.4.1.1 Airflow Requirements

The power distribution board shall get enough airflow for cooling DC/DC converters from the fans located in the Power Supply modules. Below is a basic drawing showing airflow direction.

The amount of cooling airflow that will be available to the DC/DC converters is to be no less than 1.2M/s.

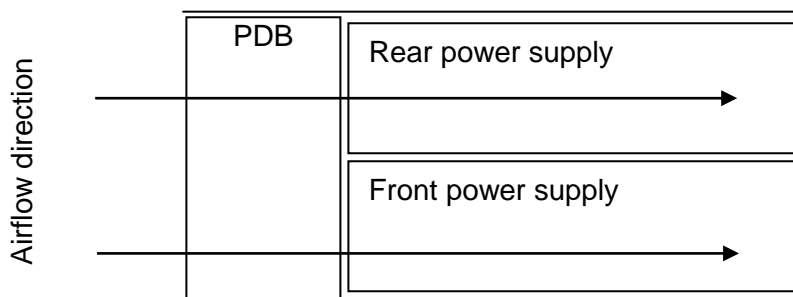

Figure 30. Airflow Diagram

2.4.1.2 DC/DC converter cooling

The dc/dc converters on the power distribution board are in series airflow path with the power supplies.

2.4.1.3 Temperature Requirements

The PDB operates within all specified limits over the Top temperature range. Some amount of airflow shall pass over the PDB.

Table 67. Thermal Requirements

Item	Description	Min	Max	Units
T _{op}	Operating temperature range.	0	50	°C
T _{non-op}	Non-operating temperature range.	-40	70	°C

2.4.1.4 Efficiency

Each DC/DC converter shall have a **minimum** efficiency of **85%** at 50% ~ 100% loads and over +12V line voltage range and over temperature and humidity range.

2.4.2 DC Output Specification

2.4.2.1 Input Connector (power distribution mating connector)

The power distribution provides two power pins, a card edge output connection for power and signal that is compatible with a 2x25 Power Card Edge connector (equivalent to 2x25 pin configuration of the FCI power card connector 10035388-102LF). The FCI power card edge connector is a new version of the PCE from FCI used to raise the card edge by 0.031" to allow

for future 0.093" PCBs in the system. The card edge connector has no keying features; the keying method is accomplished by the system sheet metal.

Table 68. Input Connector and Pin Assignment Diagrams

Pin	Name	Pin	Name
A1	GND	B1	GND
A2	GND	B2	GND
A3	GND	B3	GND
A4	GND	B4	GND
A5	GND	B5	GND
A6	GND	B6	GND
A7	GND	B7	GND
A8	GND	B8	GND
A9	GND	B9	GND
A10	+12V	B10	+12V
A11	+12V	B11	+12V
A12	+12V	B12	+12V
A13	+12V	B13	+12V
A14	+12V	B14	+12V
A15	+12V	B15	+12V
A16	+12V	B16	+12V
A17	+12V	B17	+12V
A18	+12V	B18	+12V
A19	PMBus SDA	B19	A0 (SMBus address)
A20	PMBus SCL	B20	A1 (SMBus address)
A21	PSON	B21	12V stby
A22	SMBAlert#	B22	Cold Redundancy Bus
A23	Return Sense	B23	12V load share
A24	+12V remote Sense	B24	No Connect
A25	PWOK	B25	Compatibility Pin*

Note: *The compatibility Pin is used for soft compatibility check. The two compatibility pins are connected directly.

2.4.2.2 Output Wire Harness

The power distribution board has a wire harness output with the following connectors.

Listed or recognized component appliance wiring material (AVLV2), CN, rated min 85°C shall be used for all output wiring.

Table 69. PDB Cable Length

From	Length, mm	To connector #	No of pins	Description
Power Supply cover exit hole	470	P1	24	Baseboard Power Connector

From	Length, mm	To connector #	No of pins	Description
Power Supply cover exit hole	320	P2	8	Processor 0 connector
Power Supply cover exit hole	450	P3	8	Processor 1 connector
Power Supply cover exit hole	800	P4	5	Power FRU/PMBus connector
Power Supply cover exit hole	350	P5	5	SATA peripheral power connector for 5.25"
Extension from P5	100	P6	5	SATA peripheral power connector for 5.25"
Extension from P6	100	P7	4	Peripheral Power Connector for 5.25"/HSBP Power
Power Supply cover exit hole	400	P8	4	1x4 legacy HSBP Power Connector
Extension from P8	75	P9	4	1x4 legacy HSBP Power Connector
Power supply cover exit hole	500	P10	4	1x4 legacy HSBP Power/Fixed HDD adaptor Connection
Extension from P10	75	P11	4	1x4 legacy HSBP Power/Fixed HDD adaptor Connection
PCI power connector	800	P12	4	2x2 Legacy PCI Power Connector
Connector only (no cable)	na	P13	4	GFX card aux connectors
Connector only (no cable)	na	P14	4	
Connector only (no cable)	na	P15	4	
Connector only (no cable)	na	P16	4	

2.4.2.2.1 Baseboard power connector (P1)

- Connector housing: 24-Pin Molex* Mini-Fit Jr. 39-01-2245 or equivalent
- Contact: Molex* Mini-Fit, HCS Plus, Female, Crimp 44476 or equivalent

Table 70. P1 Baseboard Power Connector

Pin	Signal	18 AWG Color	Pin	Signal	18 AWG Color
1	+3.3VDC	Orange	13	+3.3VDC	Orange
	3.3V RS	Orange (24AWG)			
2	+3.3VDC	Orange	14	-12VDC	Blue
3	COM	Black	15	COM	Black
4	+5VDC	Red	16	PSON#	Green (24AWG)
5	COM	Black	17	COM	Black
6	+5VDC	Red	18	COM	Black
7	COM	Black	19	COM	Black

Pin	Signal	18 AWG Color	Pin	Signal	18 AWG Color
8	PWR OK	Gray (24AWG)	20	Reserved	N.C.
9	5 VSB	Purple	21	+5VDC	Red
10	+12V1	Yellow	22	+5VDC	Red
11	+12V1	Yellow	23	+5VDC	Red
12	+3.3VDC	Orange	24	COM	Black

2.4.2.2.2 Processor#0 Power Connector (P2)

- Connector housing: 8-Pin Molex* 39-01-2080 or equivalent
- Contact: Molex* Mini-Fit, HCS Plus, Female, Crimp 44476 or equivalent

Table 71. P0 Processor Power Connector

Pin	Signal	18 AWG color	Pin	Signal	18 AWG Color
1	COM	Black	5*	+12V1	Yellow
2	COM	Black	6	+12V1	Yellow
3	COM	Black	7	+12V1	Yellow
4	COM	Black	8	+12V1	Yellow

2.4.2.2.3 Processor#1 Power Connector (P3)

- Connector housing: 8-Pin Molex* 39-01-2080 or equivalent
- Contact: Molex* Mini-Fit, HCS Plus, Female, Crimp 44476 or equivalent

Table 72. P1 Processor Power Connector

Pin	Signal	18 AWG color	Pin	Signal	18 AWG Color
1	COM	Black	5	+12V1	Yellow
2	COM	Black	6	+12V1	Yellow
3	COM	Black	7	+12V1	Yellow
4	COM	Black	8	+12V1	Yellow

2.4.2.2.4 Power Signal Connector (P4)

- Connector housing: 5-pin Molex* 50-57-9405 or equivalent
- Contacts: Molex* 16-02-0087 or equivalent

Table 73. Power Signal Connector

Pin	Signal	24 AWG Color
1	I2C Clock	White
2	I2C Data	Yellow
3	SMBAlert#	Red
4	COM	Black
5	3.3RS	Orange

2.4.2.2.5 2x2 12V connector (P12-P16)

Connector header: Foxconn p/n HM3502E-P1 or equivalent

Table 74. P12 12V connectors

Pin	Signal	18 AWG color	Pin	Signal	18 AWG Color
1	COM	Black	5	+12V1	Yellow
2	COM	Black	6	+12V1	Yellow

Table 75. P13 - P16 12V connectors

Pin	Signal	18 AWG color	Pin	Signal	18 AWG Color
1	COM	Black	5	+12V2	Green
2	COM	Black	6	+12V2	Green

2.4.2.2.6 Legacy 1x4 Peripheral Power Connectors (P7, P8, P9, P10, P11)

- Connector housing: Molex* 0015-24-4048 or equivalent;
- Contact: Molex* 0002-08-1201 or equivalent

Table 76. P8, P9, P10, P11 Legacy Peripheral Power Connectors

Pin	Signal	18 AWG Color
1	+12V4	White
2	COM	Black
3	COM	Black
4	+5 VDC	Red

Table 77. P7 Legacy Peripheral Power Connectors

Pin	Signal	18 AWG Color
1	+12V3	Brown
2	COM	Black
3	COM	Black
4	+5 VDC	Red

2.4.2.2.7 SATA 1x5 Peripheral Power Connectors (P5, P6)

- Connector housing: Molex* 0675-82-0000 or equivalent;
- Contact: Molex* 0675-81-0000 or equivalent

Table 78. SATA Peripheral Power Connectors

Pin	Signal	18 AWG Color
1	+3.3VDC	Orange
2	COM	Black
3	+5VDC	Red

Pin	Signal	18 AWG Color
4	COM	Black
5	+12V3	Yellow

2.4.2.3 Grounding

The ground of the pins of the PDB output connectors provides the power return path. The output connector ground pins is connected to safety ground (PDB enclosure). This grounding is well designed to ensure passing the max allowed Common Mode Noise levels.

2.4.2.4 Remote Sense

Below is listed the remote sense requirements and connection points for all the converters on the PDB and the main 12V output of the power supply.

Table 79. Remote Sense Connection Points

Converter	+ sense location	- sense location
Power supply main 12V	On PDB	On PDB
12V/3.3V	P20 (1x5 signal connector)	P20 (1x5 signal connector)
12V/5V	On PDB	On PDB
12V/-12V	none	none
12Vstby/5Vstby	none	none

Table 80. Remote Sense Requirements

Characteristic	Requirement
+3.3V remote sense input impedance	200Ω (measure from +3.3V on P1 2x12 connector to +3.3V sense on P20 1x5 signal connector)
+3.3V remote sense drop	200mV (remote sense must be able to regulate out 200mV drop on the +3.3V and return path; from the 2x12 connector to the remote sense points)
Max remote sense current draw	< 5mA

2.4.2.5 12V Rail Distribution

The below table shows the configuration of the 12V rails and what connectors and components in the system they are powering.

Table 81. 12V Rail Distribution

	P2		P3		P12	P1			P8	P9	P10	P11	P5,6,7	P13	P14	P15	P16	P17	P18	P19	P20				
	2x4		2x4		2x2	2x12			1x4	1x4	1x4	1x4	(2) 1x5, 1x4	GPU1		GPU2		GPU3		GPU4		OCP			
	CPU 1	Memo ry1	CPU2	Memo ry2	PCIe	Fans	Misc	HDD and peripherals				2x3	2x4	2x3	2x4	2x3	2x4	2x3	2x4	2x3	2x4	Total Curr ent	Min	Nom inal	Max
12V1	17.8 A	10.5 A	17.8 A	10.5 A	21.7 A	10.0 A	3.0 A															91 A	91	95.5	100
12V2													6.3 A	12.5 A	6.3 A	12.5 A	6.3 A	12.5 A	6.3 A	12.5 A		76 A	76	88	100
12V3												18.0 A										18 A	18	19	20
12V4																						18A	18	19	20

Note:

P12 is reserved for board that needs 4 x GPU cards powered. P1 is the main 12V power for PCIe slot; but additional 12V power can be connected to P2 and/or P3. The motherboard MUST NOT short any of the 12V rails or connectors together.

2.4.2.6 Hard Drive 12V rail configuration options

The below table shows the hard drive configuration options using the defined power connectors. In some cases additional converter or 'Y' cables are needed.

Table 82. Hard Drive 12V rail configuration options

	P8	P9	P10	P11	P5	P6	P7
	1x4	1x4	1x4	1x4	1x5	1x5	1x4
	18						
3 x 2.5" 8xHDD BP	HDD1 8 x 2.5	na	HDD2 8 x 2.5	na	na	na	HDD3 8 x 2.5
2 x 3.5" 4xHDD BP	HDD1 4x3.5		HDD1 4x3.5		peripheral bay		
1 x 3.5" 8xHDD BP	HDD1 8x3.5		na	na	peripheral bay		
8 x 3.5" fixed SATA	2xfixed	2xfixed	2xfixed	2xfixed	peripheral bay		
8 x 3.5" fixed SAS	2xfixed	2xfixed	2xfixed	2xfixed	peripheral bay		

2.4.2.7 DC/DC Converters Loading

The following table defines power and current ratings of three DC/DC converters located on the PDB, each powered from +12V rail. The 3 converters meet both static and dynamic voltage regulation requirements for the minimum and maximum loading conditions.

Table 83. DC/DC Converters Load Ratings

	+12VDC Input DC/DC Converters		
	+3.3V Converter	+5V Converter	-12V Converter
MAX Load	25A	15A	0.5A
MIN Static/Dynamic Load	0A	0A	0A
Max Output Power	3.3V x25A =82.5W	5V x15A =75W	12V x0.5A =6W

2.4.2.8 5VSB Loading

There is also one DC/DC converter that converts the 12V standby into 5V standby.

Table 84. 5VSB Loading

	12V stby/5V stby DC/DC Converters
MAX Load	8A
MIN Static/Dynamic Load	0.1
Max Output Power	5V x8A =40W

2.4.2.9 DC/DC Converters Voltage Regulation

The DC/DC converters' output voltages stay within the following voltage limits when operating at steady state and dynamic loading conditions. These limits include the peak-peak ripple/noise specified in Table 95. The 3.3V and 5V outputs are measured at the remote sense point, all other voltages measured at the output harness connectors.

Table 85. Voltage Regulation Limits

Converter output	Tolerance	Min	Nom	Max	Units
+ 3.3VDC	-4%/+5%	+3.20	+3.30	+3.46	VDC
+ 5VDC	-4%/+5%	+4.80	+5.00	+5.25	VDC
5Vstby	-4%/+5%	+4.80	+5.00	+5.25	VDC

2.4.2.10 DC/DC Converters Dynamic Loading

The output voltages remains within limits specified in table above for the step loading and capacitive loading specified in Table 93 below. The load transient repetition rate is only a test specification. The Δ step load may occur anywhere within the MIN load to the MAX load shown in Tables 93 and 94.

Table 86. Transient Load Requirements

Output	Max Δ Step Load Size	Max Load Slew Rate	Test capacitive Load
+ 3.3VDC	5A	0.25 A/ μ s	250 μ F
+ 5VDC	5A	0.25 A/ μ s	400 μ F
+5Vsb	0.5A	0.25A/ μ s	20 μ F

2.4.2.11 DC/DC Converter Capacitive Loading

The DC/DC converters is stable and meet all requirements with the following capacitive loading ranges. Minimum capacitive loading applies to static load only.

Table 87. Capacitive Loading Conditions

Converter output	Min	Max	Units
+3.3VDC	250	6800	μ F
+5VDC	400	4700	μ F
5Vstby	20	350	μ F

2.4.2.12 DC/DC Converters Closed Loop stability

Each DC/DC converter is unconditionally stable under all line/load/transient load conditions including capacitive load ranges specified in Section 2.4.2.11. A minimum of: **45 degrees phase margin** and **-10dB-gain margin** is required. The PDB provides proof of the unit's closed-loop stability with local sensing through the submission of Bode plots. Closed-loop stability must be ensured at the maximum and minimum loads as applicable.

2.4.2.13 Common Mode Noise

The Common Mode noise on any output does not exceed 350mV pk-pk over the frequency band of 10Hz to 20MHz.

- The measurement shall be made across a 100Ω resistor between each of DC outputs, including ground, at the DC power connector and chassis ground (power subsystem enclosure).
- The test set-up shall use a FET probe such as Tektronix model P6046 or equivalent.

2.4.2.14 Ripple/Noise

The maximum allowed ripple/noise output of each DC/DC Converter is defined in below Table 95. This is measured over a bandwidth of 0Hz to 20MHz at the PDB output connectors. A 10μF tantalum capacitor in parallel with a 0.1μF ceramic capacitor are placed at the point of measurement.

Table 88. Ripple and Noise

+3.3V	+5V	-12V	+5VSB
50mVp-p	50mVp-p	120mVp-p	50mVp-p

The test set-up shall be as shown below.

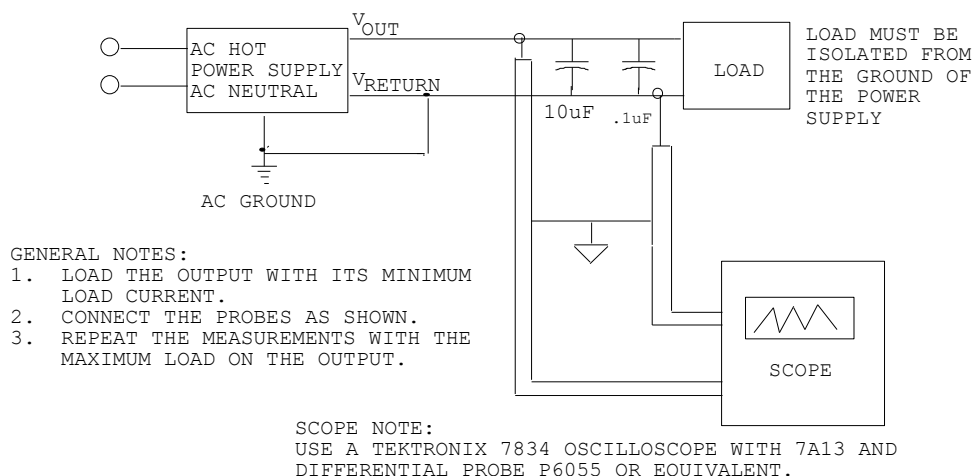

Note:

When performing this test, the probe clips and capacitors should be located close to the load.

Figure 31. Differential Noise test setup

2.4.2.15 Timing Requirements

Below are timing requirements for the power on/off of the PDB DC/DC converters. The +3.3V, +5V and +12V output voltages should start to rise approximately at the same time. All outputs must rise monotonically.

Table 89. Output Voltage Timing

Description	Min	Max	Units
Output voltage rise time for each main output; 3.3V, 5V, -12V and 5Vstby.	1.0	20	msec
The main DC/DC converters (3.3V, 5V, -12V) shall be in regulation limits within this time after the 12V input has reached 11.4V.		20	msec
The main DC/DC converters (3.3V, 5V, -12V) must drop below regulation limits within this time after the 12V input has dropped below 11.4V.		20	msec
The 5Vstby converter shall be in regulation limits within this time after the 12Vstby has reach 11.4V.		20	msec
The 5Vstby converter must power off within this time after the 12Vstby input has dropped below 11.4V.		100	msec

2.4.2.16 Residual Voltage Immunity in Standby Mode

Each DC/DC converter is immune to any residual voltage placed on its respective output (typically a leakage voltage through the system from standby output) up to 500mV. This residual voltage does not have any adverse effect on each DC/DC converter, such as: no additional power dissipation or over-stressing/over-heating any internal components or adversely affecting the turn-on performance (no protection circuits tripping during turn on).

While in Stand-by mode, at no load condition, the residual voltage on each DC/DC converter output does not exceed 100mV.

2.4.3 Protection Circuits

The PDB shall shut down all the DC/DC converters on the PDB and the power supply (from PSON) if there is a fault condition on the PDB (OVP or OCP). If the PDB DC/DC converter latches off due to a protection circuit tripping, an AC cycle OFF for 15sec min or a PSON# cycle HIGH for 1sec shall be able to reset the power supply and the PDB.

2.4.3.1 Over-Current Protection (OCP)/240VA Protection

Each DC/DC converter output on PDB has individual OCP protection circuits. The PS+PDB combo shall shutdown and latch off after an over current condition occurs. This latch shall be cleared by toggling the PSON# signal or by an AC power interruption. The values are measured at the PDB harness connectors. The DC/DC converters shall not be damaged from repeated power cycling in this condition. Also, the +12V output from the power supply is divided on the PDB into 3 channels and +12V3 is limited to 240VA of power. There are current sensors and limit circuits to shut down the entire PS+PDB combo if the limit is exceeded. The limits are listed in below table. -12V and 5VSB is protected under over current or shorted conditions so that no damage can occur to the power supply. Auto-recovery feature is a requirement on 5VSB rail.

Table 90. PDB Over Current Protection Limits/240VA Protection

Output Voltage	Min OCP Trip Limits	Max OCP Trip Limits	Usage
+3.3V	27A	Meet 240VA	PCIe, Misc
+5V	27A		PCIe, HDD, Misc
+12V1	91A	100A	CPU and memory
+12V2	76A	100A	GPU cards
+12V3	18A	20A	HDD and peripherals
+12V4	18A	20A	HDD and peripherals

2.4.3.2 Over Voltage Protection (OVP)

Each DC/DC converter output on PDB have individual OVP protection circuits built in and it shall be locally sensed. The PS+PDB combo shall shutdown and latch off after an over voltage condition occurs. This latch shall be cleared by toggling the PSON[#] signal or by an AC power interruption. Table 135 contains the over voltage limits. The values are measured at the PDB harness connectors. The voltage shall never exceed the maximum levels when measured at the power pins of the output harness connector during any single point of fail. The voltage shall never trip any lower than the minimum levels when measured at the power pins of the PDB connector.

Table 91. Over Voltage Protection (OVP) Limits

Output voltage	OVP min (v)	OVP max (v)
+3.3V	3.9	4.8
+5V	5.7	6.5
+5VSB	5.7	6.5

2.4.4 PWOK (Power OK) Signal

The PDB connects the PWOK signals from the power supply modules and the DC/DC converters to a common PWOK signal. This common PWOK signal connects to the PWOK pin on P1. The DC/DC convert PWOK signals have open collector outputs.

2.4.4.1 System PWOK requirements

The system will connect the PWOK signal to 3.3V or 5V from a pull-up resistor. The maximum sink current of the power supplies are 0.5mA. The minimum resistance of the pull-up resistor is stated below depending upon the motherboard's pull-up voltage. Refer to the CRPS power supply specification for signal details.

Table 92. System PWOK Requirements

Motherboard pull-up voltage	MIN resistance value (ohms)
5V	10K
3.3V	6.8K

2.4.5 PSON Signal

The PDB connects the power supplies PSON signals together and connect them to the PSON signal on P1.

Refer to the CRPS power supply specification for signal details.

2.4.6 PMBus

The PDB has no components on it to support PMBus. It only needs to connect the power supply PMBus signals (clock, data, SMBAlert#) and pass them to the 1x5 signal connector.

2.4.6.1 Addressing

The PDB address the power supply as follows on the PDB.

0 = open, 1 = grounded

Table 93. PDB addressing

	Power Supply Position 1	Power Supply Position 2
PDB addressing Address0/Address1	0/0	0/1
Power supply PMBus device address	B0h	B2h

3. Thermal Management

The Intel® Server System P4000IP is designed to operate at external ambient temperatures of between 10°C- 35°C. Working with integrated platform management, several features within the system are designed to move air in a front to back direction, through the system and over critical components in order to prevent them from overheating and allow the system to operate with best performance.

3.1 Thermal Operation and Configuration Requirements

To keep the system operating within supported maximum thermal limits, the system must meet the following operating and configuration guidelines:

- Ambient in-let temperature cannot exceed 35° C and should not remain at this maximum level for long periods of time. Doing so may affect long term reliability of the system.
- All hard drive bays must be populated. Hard drive carriers either can be populated with a hard drive or supplied drive blank.
- The air duct must be installed at all times.
- In single power supply configurations, the second power supply bay must have the supplied filler blank installed at all times.
- The system top-cover must be installed at all times.
- CPU2 Memory Socket Dummy Dimm must be installed.

3.2 Thermal Management Overview

In order to maintain the necessary airflow within the system, all of the previously listed components and top cover need to be properly installed. For best system performance, the external ambient temperature must remain below 35°C and all system fans should be operational.

In the event that system thermals should continue to increase with the system fans operating at their maximum speed, platform management may begin to throttle performance of either the memory subsystem or the processors or both, in order to keep components from overheating and keep the system operational. Throttling of these sub-systems will continue until system thermals are reduced.

Should system thermals increase to a point beyond the maximum thermal limit as pre-programmed in platform management for this system, the system will shut down, the System Status LED will change to a solid Amber state, and the event will be logged to the system event log.

3.3 System Fan Configuration

Two cooling solutions are used in the Intel® Server Chassis P4000L series. The base non-redundant solution consists of two 120 x 38mm fixed fans to provide sufficient system cooling. The second redundant solution is designed for maximum up time by providing five 80 x 38 mm replaceable hot-swap fans. The fans can maintain proper system cooling, even with a single failed fan.

Corresponding air ducts are needed in both configurations for supported boards.

3.3.1 Non-Redundant Cooling Solution

Non-Redundant cooling solution is used in the Intel® Workstation System P4000CR.

Two 120 x 38 mm fans provide cooling for the processors, memory, hard drives and add-in cards. The two fans draw air through the rear of each hard drive bay to provide drive, processors, and memory cooling. All system fans provide a signal for RPM detection the server board can make available for server management functions.

In addition, the power supply fan provides cooling for the power supply.

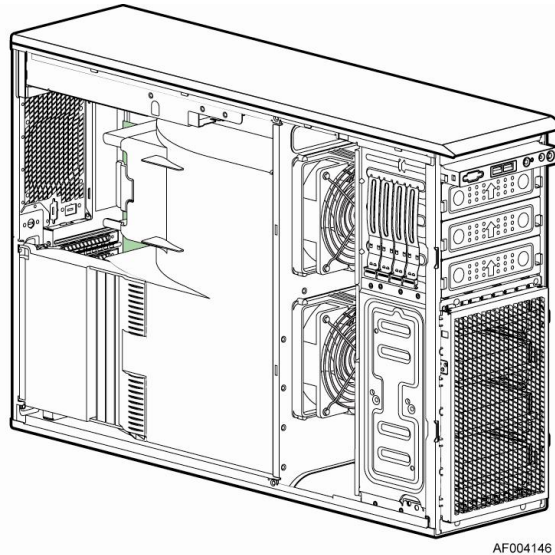

Figure 32. Fixed Fans in Intel® Workstation System P4000CR

3.3.2 Redundant Cooling Solution

Redundant cooling solution is used in the Intel® Server System P4000IP.

Five hot-swap 80x38mm fans provide cooling for the processors, hard drives, and add-in cards. When any single fan fails, the remaining fans increase in speed and maintain cooling until the failed unit is replaced. All system fans provide a signal for RPM detection that the server board can make available for server management functions.

In addition, the power supply fan provides cooling for the power supply.

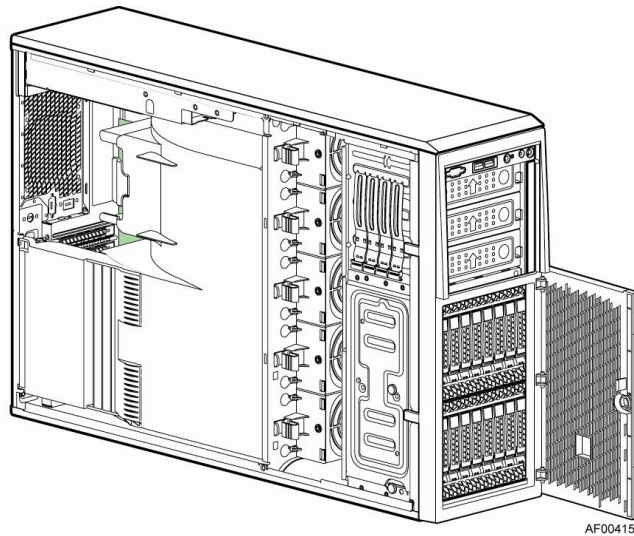

Figure 33. Hot-swap Fans in Intel® Server System P4000IP

3.4 Fan Control

The fans provided in the Intel® Server Chassis P4000M Family contains a tachometer signal that can be monitored by the server management subsystem of the Intel® Server Boards for RPM (Revolutions per Minute) detection.

The server board monitors several temperature sensors and adjusts the PWM (Pulse Width Modulated) signal to drive the fan at the appropriate speed.

The front panel of the chassis has a digital temperature sensor connected to the server board through the front panel's bus. The server board firmware adjusts the fan speed based on the front panel intake temperature and processor temperatures.

Refer to the baseboard documentation for additional details on how fan control is implemented.

3.5 Fan Header Connector Descriptions

All system fan headers support pulse width modulated (PWM) fans for cooling the processors in the chassis. PWM fans have an improved RPM range (20% to 100% rated fan speed) when compared to voltage controlled fans.

Fixed chassis fans are a 4-wire/4-pin style designed to plug into 4-pin or 6-pin SSI Fan headers. When plugged into a 6-pin header, only the first four signals are used (Pwr, Gnd, Tach, PWM).

Hot-swap chassis fans are a 6-wire/6-pin style designed to plug into 6-pin headers. The extra signals provide for fan redundancy and failure indications (Pwr, Gnd, Tach, PWM, Presence, and Failure).

4. Storage and Peripheral Drive Bays

The Intel® Server System P4000IP and the Intel® Workstation System P4000CR product family has support for many storage device options, including:

- Hot Swap 2.5" Hard Disk Drives
- Hot Swap 3.5" Hard Disk Drives
- SAS Expender Option
- SATA Optical Drive
- eUSB Solid State Device (eUSB SSD)

Support for different storage and peripheral device options will vary depending on the system SKU. This section will provide an overview of each available option.

4.1 2.5" Hard Disk Drive Support

The Intel® Server System P4000IP support 8x2.5" drive configuration. The drive bay can support either SATA or SAS hard disk drives. Mixing of drive types within the hard drive bay is not supported. Hard disk drive type is dependent on the type of host bus controller used, SATA only or SAS. Each 2.5" hard disk drive is mounted to a drive tray, allowing for hot swap extraction and insertion. Drive trays have a latching mechanism that is used to extract and insert drives from the chassis, and lock the tray in place.

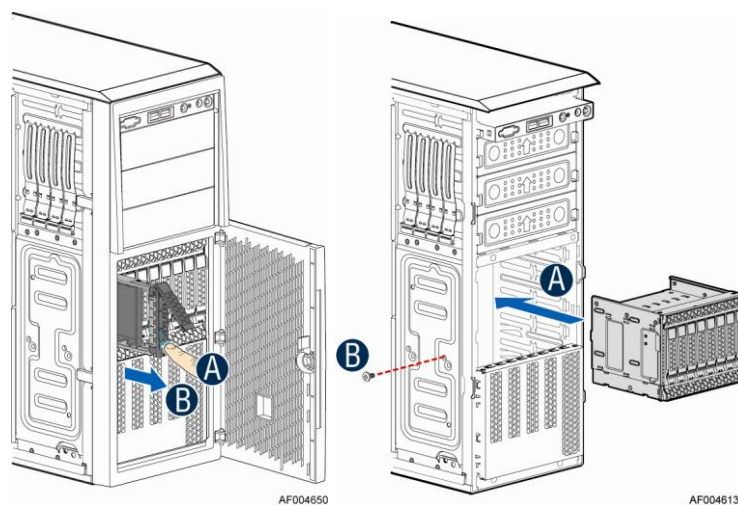

Figure 34. 2.5" Hard Disk Drive Cage

Light pipes integrated into the drive tray assembly direct light emitted from Amber drive status and Green activity LEDs located next to each drive connector on the backplane, to the drive tray faceplate, making them visible from the front of the system.

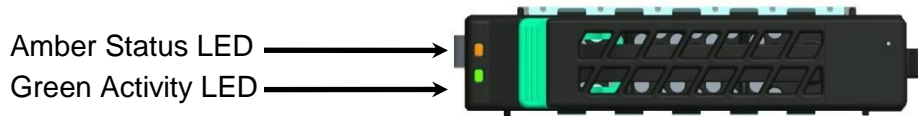

Figure 35. 2.5" Hard Disk Drive Support - LED Status

Table 94. 2.5" Hard Disk Drive Status LED States

Amber	Off	No access and no fault
	Solid On	Hard Drive Fault has occurred
	Blink	RAID rebuild in progress (1 Hz), Identify (2 Hz)

Table 95. 2.5" Hard Disk Drive Activity LED States

	Condition	Drive Type	Behavior
Green	Power on with no drive activity	SAS	LED stays on
		SATA	LED stays off
	Power on with drive activity	SAS	LED blinks off when processing a command
		SATA	LED blinks on when processing a command
	Power on and drive spun down	SAS	LED stays off
		SATA	LED stays off
Power on and drive spinning up	SAS	LED blinks	
	SATA	LED stays off	

4.1.1 2.5" Drive Hot-Swap Backplane Overview

Depending on the number of hard disk drives supported by a given system SKU, a system can be configured with 1, 2, or 3 eight drive backplanes. Each backplane is attached to the back of the drive bay assembly. On the front side of each backplane are mounted eight hard disk drive interface connectors (A), each providing both power and I/O signals to attached hard disk drives.

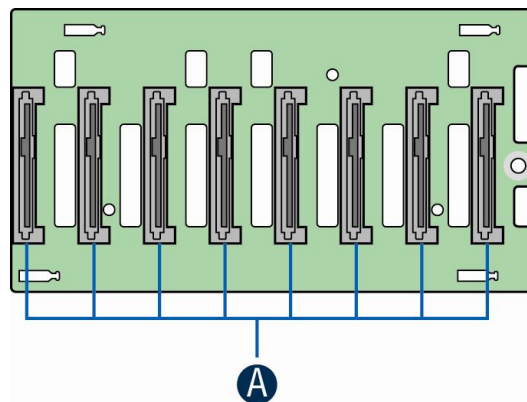

AF004024

Figure 36. 2.5" Backplane, Front Side

There are several connectors on the backside of each backplane. The following illustration identifies each of them:

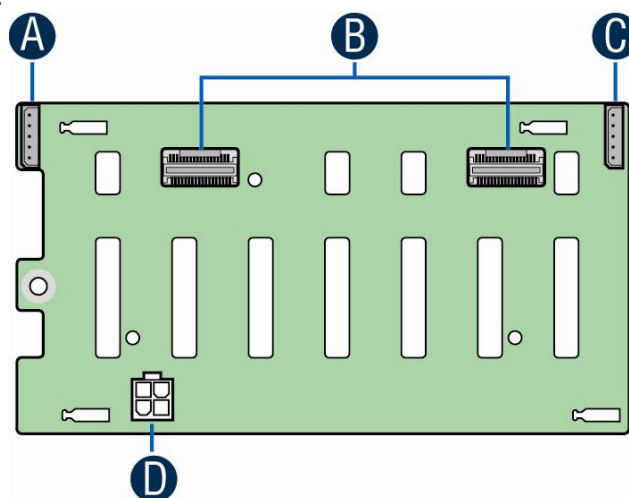

AF004025

Label	Description
A	4-port Mini-SAS cable connectors
B	SMBus-Out cable connector for multi-backplane support
C	Power connector
D	SMBus-In cable connector – From Server board or other backplane

Figure 37. 2.5" Backplane, Back Side

A – Multi-port Mini-SAS Cable Connectors – The backplane includes two multi-port mini-SAS cable connectors, each providing I/O signals for four SAS/SATA hard drives on the backplane. Cables can be routed from matching connectors on the server board, add-in SAS/SATA RAID cards, or optionally installed SAS expander cards.

B and D – SMBus Cable Connectors – The backplane includes two 1x5 cable connectors used as a management interface between the server board and the installed backplanes. In systems configured with multiple backplanes, a short jumper cable is attached between backplanes, with connector B used on the first board and connector D used on the second board, extending the SMBus to each installed backplane.

C – Power Harness Connector – The backplane includes a 2x2 connector supplying power to the backplane. Power is routed to each installed backplane by a multi-connector power cable harness from the server board.

4.1.2 Cypress* CY8C22545 Enclosure Management Controller

The backplanes support enclosure management using a Cypress* CY8C22545 Programmable System-on-Chip (PSoC*) device. The CY8C22545 drives the hard drive activity/fault LED, hard drive present signal, and controls hard drive power-up during system power-on.

4.2 3.5" Hard Disk Drive Support

The Intel® Server System P4308CP4MHEN and P4308CP4MHGC support 8x3.5" drive configuration. The drive bay can support either SATA or SAS hard disk drives. Mixing of drive types within the hard drive bay is not supported. Hard disk drive type is dependent on the type of host bus controller used, SATA only or SAS. Each 3.5" hard disk drive is mounted to a drive tray, allowing for hot swap extraction and insertion. Drive trays have a latching mechanism that is used to extract and insert drives from the chassis, and lock the tray in place.

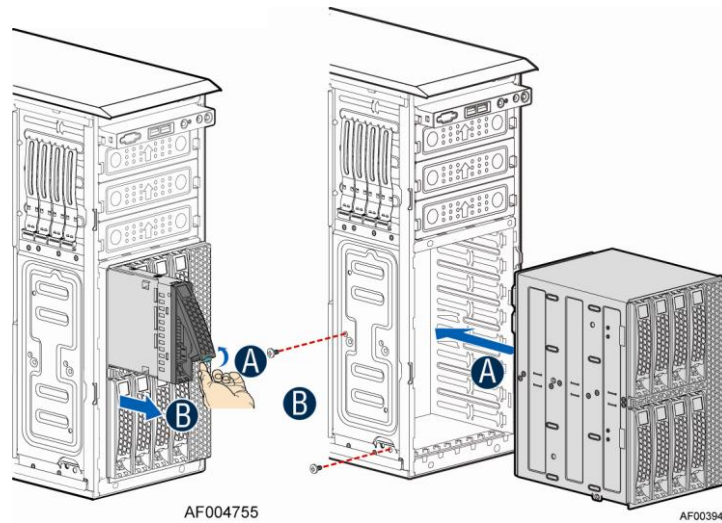

Figure 38. 3.5" Hard Disk Drive Cage

Light pipes integrated into the drive tray assembly direct light emitted from Amber drive status and Green activity LEDs located next to each drive connector on the backplane, to the drive tray faceplate, making them visible from the front of the system.

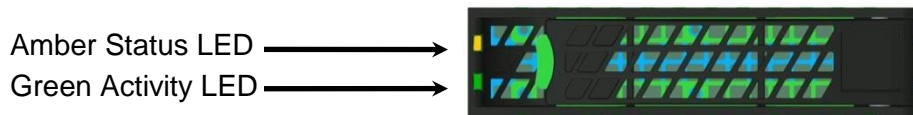

Figure 39. 3.5" Hard Disk Drive Support - LED Status

Table 96. 3.5" Hard Disk Drive Status LED States

Amber	Off	No access and no fault
	Solid On	Hard Drive Fault has occurred
	Blink	RAID rebuild in progress (1 Hz), Identify (2 Hz)

Table 97. 3.5" Hard Disk Drive Activity LED States

Green	Condition	Drive Type	Behavior
	Power on with no drive activity		SAS
SATA			LED stays off
Power on with drive activity		SAS	LED blinks off when processing a command
		SATA	LED blinks on when processing a command
Power on and drive spun down		SAS	LED stays off
		SATA	LED stays off
Power on and drive spinning up		SAS	LED blinks
		SATA	LED stays off

4.2.1 3.5" Drive Hot-Swap Backplane Overview

The backplane mount to the back of the drive bay assembly. On the front side the back plane are mounted eight hard disk drive interface connectors (A), each providing both power and I/O signals to the attached hard disk drives.

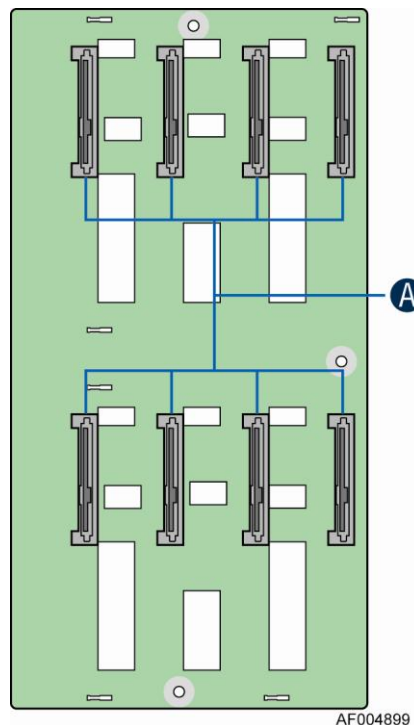
**Figure 40. 3.5" Backplane, Front Side**

On the backside of each backplane are several connectors. The following illustration identifies each.

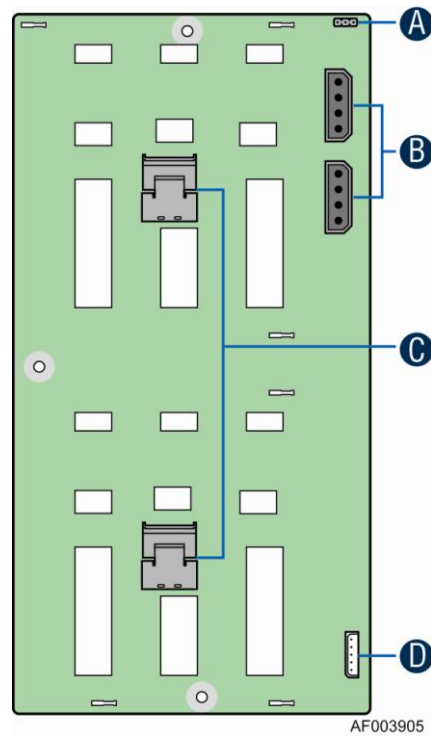

Label	Description
A	Reserved
B	Power connector
C	4-port mini-SAS connectors
D	SMBus connector
E	Drive connector interface

Figure 41. 2.5" Backplane, Back Side

A – Reserved

B – Power Harness Connector - The backplane includes a 2x2 connector supplying power to the backplane. Power is routed to the backplane by a power cable harness from the server board

C – 4-port Mini-SAS Connectors – The backplane includes two or three multi-port mini-SAS cable connectors, each providing I/O signals for four SAS/SATA hard drives on the backplane. Cables can be routed from matching connectors on the server board, add-in SAS/SATA RAID cards, or optionally installed SAS expander cards. Each mini-SAS connector will include a silk-screen identifying which drives the connector supports; Drives 0-3 and Drives 4-7.

D – SMBus Cable Connectors – The backplane includes a 1x5 cable connector used as a management interface to the server board.

4.2.2 Cypress* CY8C22545 Enclosure Management Controller

The backplanes support enclosure management using a Cypress* CY8C22545 Programmable System-on-Chip (PSoC*) device. The CY8C22545 drives the hard drive activity/fault LED, hard drive present signal, and controls hard drive power-up during system power-on.

4.3 SAS Expander Card Option

The 24-port SAS expander card and 36-port expander card is an optional accessory that can support up to 16 Hard drivers and 24 Hard drivers 2.5" hard disk drives. The expander card can be mounted directly behind the drive bay assembly as shown in the following illustration.

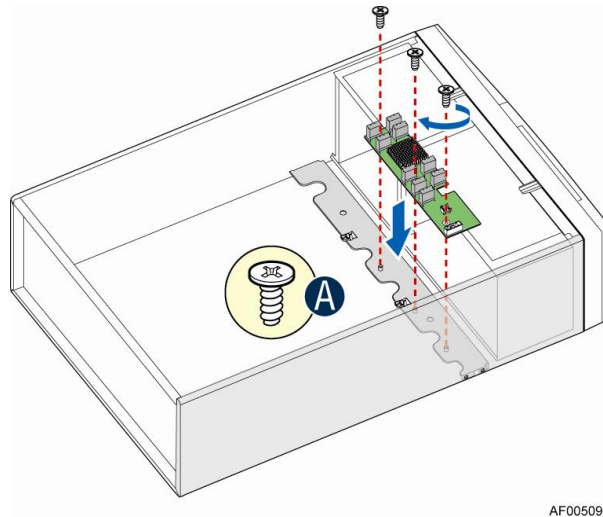

Figure 42. Internal SAS Expander Installation

The following diagrams are used to help identify the mini-SAS connectors found on the SAS expander cards. Care should be taken when connecting connectors from the SAS expander to the connectors on the backplane because each connector is pre-programmed at the factory to provide specific drive identification mapping. Improper connections may provide undesirable drive mappings.

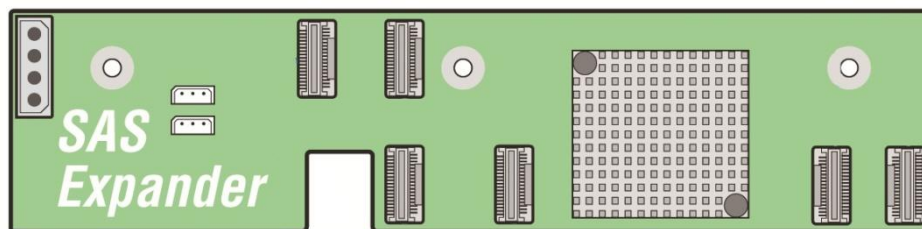

Figure 43. Internal 24-Port SAS Expander Card

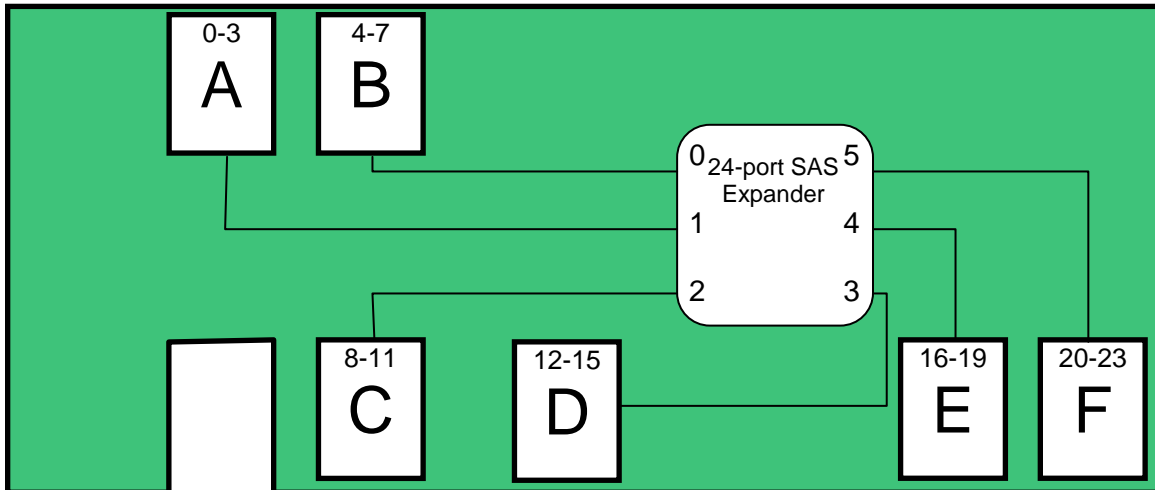

Figure 44. 24-Port Expander SAS Connector/Drive Identification Block Diagram

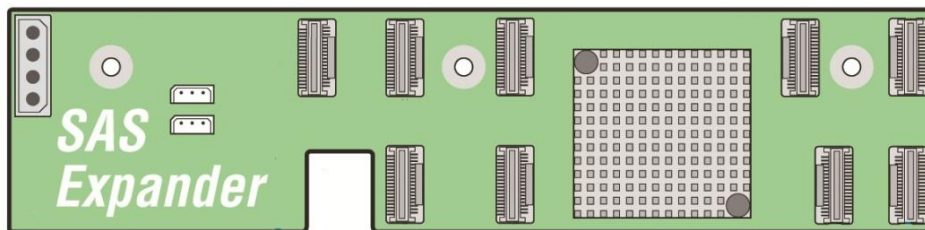

Figure 45. Internal 36-Port SAS Expander Card

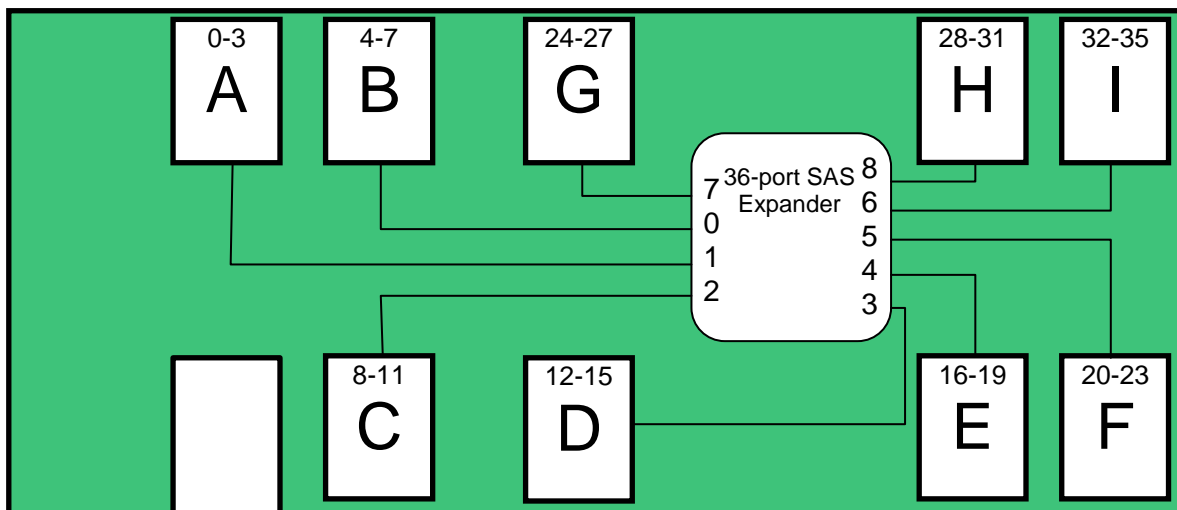

Figure 46. 36-Port Expander SAS Connector/Drive Identification Block Diagram

Each connector on the SAS expander card can be used as a “cable in” (SAS Controller to SAS Expander) or “cable out” (SAS Expander to Hot Swap Backplane) type connector. However, for contiguous drive mapping (0 – 16 or 0 – 24), cable routing differs when using a x8 wide-port capable 6 Gb SAS/SAS RAID Controller vs. using the embedded SCU ports.

4.3.1.1 Cable Routing using a x8 wide-port capable 6 Gb SAS/SAS RAID Controller

To ensure contiguous drive mapping when using x8 wide-port capable 6 Gb SAS/SAS RAID Controller with a SAS expander card, the system must be cabled as follows:

- Cables from the SAS Expander to the hot swap backplane must be connected in order: A – D for 16-drive configurations, and A – F for 24 drive configurations.
- The cables from the SAS controller can be attached to any of the remaining connectors on the SAS expander card.

4.3.1.2 Cable Routing using the embedded SCU ports

Note: The following may also be applied when using any 3 Gb SAS/SAS RAID Controller.

For storage configurations that utilize up to 16 or 24 hard disk drives for storage only and an internally mounted SSD as a boot device, the system must be configured as follows to ensure contiguous drive mapping (0 – 16 or 0-24):

- At least one internally mounted SSD device must be attached to the AHCI controller (SATA_0 or SATA_1 on the server board) and used as a boot device.
- Cables from the SAS Expander to the hot swap backplane must be connected in order: **B – E** for 16-drive configurations, and **B – G** for 24 drive configurations.
- The **SCU_0 or 3G SAS/SAS RAID (0-3)** connector is cabled to the first mini-SAS connector on the hot swap backplane
- The **SCU_1 or 3G SAS/SAS RAID (4-7)** connector is cable to **Connector A** on the SAS expander card.

For storage configurations that require utilizing a hard disk drive as the boot device, the system must be cabled as follows to ensure a boot device is found and for contiguous drive mapping (0-16 or 0-24).

- The **SCU_0 (0-3)** connector on the server board is cabled to the first mini-SAS connector on the hot swap backplane
- The **SCU_1 (4-7)** connector on the server board is cable to **Connector A** on either the 24-port or 36-port SAS expander card.
- **Cables from the SAS Expander to the hot swap backplane must be connected in order:** B – F on the 24-port expander card, and B – G on the 36-port expander card.

Note: Current SCU controller design limitations prevent any hard drive attached to a SAS expander card from being a boot device when both SCU connectors are attached to the SAS expander card.

Please reference the *Intel® Server System P4000IP Product Family Service Guide* for cable routing diagrams illustrating a variety of different storage configurations.

4.3.1 Protocol Support

Each port on the expander cards support SAS devices, SATA II devices, or both using SSP, SMP, STP, and SATA II as follows:

- Serial SCSI Protocol (SSP) to enable communication with other SAS devices.
- SATA II Protocol to enable communication with other SATA II devices.
- Serial Management Protocol (SMP) to share topology management information with expanders.
- Serial Tunneling Protocol (STP) support for SATA II through expander interfaces.
- SAS protocol, described in the Serial Attached SCSI (SAS) Standard, version 2.0
- SFF-8485 protocol, using the Serial GPIO (SGPIO) interface provided by the expander.

4.3.2 SAS Expander Features

- Supports both Serial Attached SCSI and Serial ATA devices
- 6.0 Gbit/s, 3.0 Gbit/s, and 1.5 Gbit/s data transfer rate
- SFF-8087 mini-SAS connectors
- Output mini-SAS connectors support sideband SGPIO as per SFF-8485 specification
- Provides a low-latency connection to create and maintain transparent access to each connected SAS/SATA physical drive
- Staggered spin-up
- Hot Plug
- Native Command Queuing
- Allows multiple initiators to address a single target (in a fail-over configuration)

4.4 Optical Drive Support

The Intel® Server System P4000CP includes support three 5.25" optical drive bays. The optical drives can be installed to one of the three drive bays as illustrated below. The data cable from optical drive is recommended to connect to the white SATA 6G connectors on the server board.

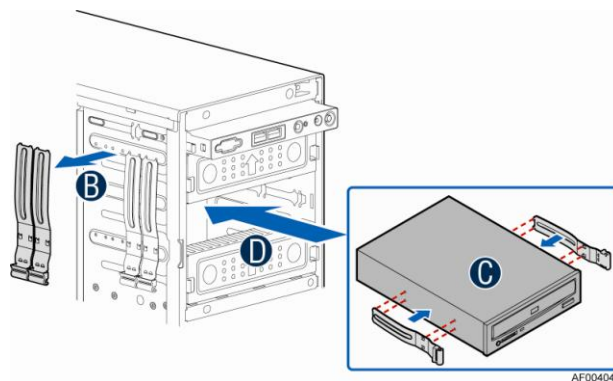

Figure 47. Optical Drive

4.5 Low Profile eUSB SSD Support

The system provides support for a low profile eUSB SSD storage device. A 2mm 2x5-pin connector labeled “eUSB SSD” near the rear I/O section of the server board is used to plug these small flash storage devices.

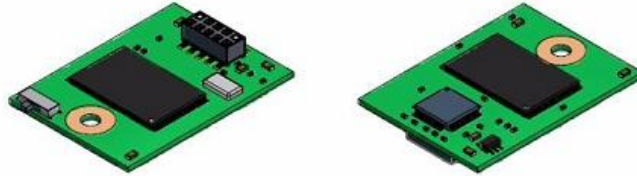

Figure 48. eUSB SSD Support

The eUSB features include:

- Two wire small form factor Universal Serial Bus 2.0 (Hi-Speed USB) interface to host.
- Read Speed up to 35 MB/s and write Speed up to 24 MB/s.
- Capacity range from 256GB to 32GB.
- Support USB Mass Storage Class requirements for Boot capability.

5. Reliability and Availability

5.1 Mean Time between Failure

The following is the calculated Mean Time Between Failures (MTBF) at maximum configuration at 40°C (ambient air). These values are derived using a historical failure rate and multiplied by factors for application, electrical and/or thermal stress and for device maturity. MTBF estimates should be viewed as “reference numbers” only.

- Telcordia SR_332 Issue II: Reliability Prediction Procedure
- Method 1: Parts Count Prediction
- Case III: Generic Value + Quality + Stress + Temperature
- Confidence Level: 90%
- Quality Level: II
- Temperature: Customer Specified (default 40 °C)
- Duty Cycle: Continuous, 100%
- Operating Environment: Ground Benign, Fixed, Controlled

Table 98. Calculated Mean Time Between Failure

Subassembly (Server in 40C ambient air)	Server Model	
	P4216IP4LHJC	
	MTBF (hours)	FIT (flrs/10 ⁹ hrs)
Intel® Server board S2600IP	200,730	4,982
Power Supply - 1200W CRPS (x2)	888,444	1,126
PDB board	1,675,959	597
Redundant Cooling Fan (x5)	108,708	9,199
Backplane board - HSBP8x2.5" (x2)	1,375,447	727
Front Panel board	8,272,282	121
RMM4	10,960,687	91
Totals without motherboard =	84300	11,860
Totals with motherboard =	59300	16,842

Subassembly (Server in 40C ambient air)	Server Model	
	P4208IP4LHGC	
	MTBF (hours)	FIT (flrs/10 ⁹ hrs)
Intel® Server board S2600IP	200,730	4,982
Power Supply - 750W CRPS (x2)	806,373	1,240
PDB board	1,675,959	597
Redundant Cooling Fan (x5)	108,708	9,199
Backplane board - HSBP8x2.5"	2,750,894	364
Front Panel board	8,272,282	121
RMM4	10,960,687	91

Subassembly (Server in 40C ambient air)	Server Model	
	P4208IP4LHGC	
	MTBF	FIT
	(hours)	(flrs/10 ⁹ hrs)
Totals without motherboard =	86100	11,611
Totals with motherboard =	60200	16,593

Subassembly (Server in 40C ambient air)	Server Model	
	P4308IP4LHJC	
	MTBF	FIT
	(hours)	(flrs/10 ⁹ hrs)
Intel® Server board S2600IP	200,730	4,982
Power Supply - 1200W CRPS (x2)	888,444	1,126
PDB board	1,675,959	597
Redundant Cooling Fan (x5)	108,708	9,199
Backplane board - HSBP8x3.5"	712,161	1,404
Front Panel board	8,272,282	121
RMM4	10,960,687	91
Totals without motherboard =	79700	12,538
Totals with motherboard =	57000	17,519

Subassembly (Server in 40C ambient air)	Server Model	
	P4308IP4LHGC	
	MTBF	FIT
	(hours)	(flrs/10 ⁹ hrs)
Intel® Server board S2600IP	200,730	4,982
Power Supply - 750W CRPS (x2)	806,373	1,240
PDB board	1,675,959	597
Redundant Cooling Fan (x5)	108,708	9,199
Backplane board - HSBP8x3.5"	712,161	1,404
Front Panel board	8,272,282	121
RMM4	10,960,687	91
Totals without motherboard =	79000	12,652
Totals with motherboard =	56700	17,634

Subassembly (Server in 40C ambient air)	Server Model	
	P4304CR2LFJN	
	MTBF	FIT
	(hours)	(flrs/10 ⁹ hrs)
Intel® Workstation board W2600CR	190,561	5,248
Power Supply - 1200W CRPS	592,296	1,688
PDB board	1,675,959	597
NR Cooling Fan - CPU fan	157,350	6,355
NR Cooling Fan - PCI fan	490,000	2,041
Front Panel board	8,272,282	121

Subassembly (Server in 40C ambient air)	Server Model	
	P4304CR2LFJN	
	MTBF	FIT
	(hours)	(flrs/10 ⁹ hrs)
RMM4	10,960,687	91
Totals without motherboard =	91800	10,893
Totals with motherboard =	61900	16,141

Subassembly (Server in 40C ambient air)	Server Model	
	P4304CR2LFGN	
	MTBF	FIT
	(hours)	(flrs/10 ⁹ hrs)
Intel® Workstation board W2600CR	190,561	5,248
Power Supply - 750W CRPS	537,582	1,860
PDB board	1,675,959	597
NR Cooling Fan - CPU fan	157,350	6,355
NR Cooling Fan - PCI fan	490,000	2,041
Front Panel board	8,272,282	121
RMM4	10,960,687	91
Totals without motherboard =	90300	11,065
Totals with motherboard =	61300	16,313

6. Environmental Limits

6.1 System Environment Limits

The following table defines the Intel® Server System P4000IP and Intel® Workstation System P4000CR system level operating and non-operating environmental limits. Operation of the Intel® Server System P4000IP and Intel® Workstation System P4000CR at conditions beyond those shown in the following table may cause permanent damage to the system. Exposure to absolute maximum rating conditions for extended periods may affect system reliability.

Table 99. System Environment Limits Summary

Parameter		Limits			
Temperature					
	Operating	10° C to 35° C ¹ (50° F to 95° F) with the maximum rate of change not to exceed 10°C per hour			
	Non-Operating	-40° C to 70° C (-40° F to 158° F)			
Humidity					
	Non-Operating	50% to 90%, non-condensing with a maximum wet bulb of 28° C (at temperatures from 25° C to 35° C)			
Shock					
	Operating	Half sine, 2g, 11 mSec			
	Unpackaged	Trapezoidal, 25 g, velocity change is based on packaged weight			
	Packaged	Product Weight: ≥ 40 to < 80 Non-palletized Free Fall Height = 18 inches Palletized (single product) Free Fall Height = NA			
Vibration					
	Unpackaged	5 Hz to 500 Hz 2.20 g RMS random			
	Packaged	5 Hz to 500 Hz 1.09 g RMS random			
AC-DC					
	Voltage	90 Hz to 132 V and 180 V to 264 V			
	Frequency	47 Hz to 63 Hz			
	Source Interrupt	No loss of data for power line drop-out of 12 mSec			
	Surge Non-operating and operating	Unidirectional			
	Line to earth Only	AC Leads	2.0 kV		
		I/O Leads	1.0 kV		
		DC Leads	0.5 kV		
ESD					
	Air Discharged	12.0 kV			
	Contact Discharge	8.0 kV			
Acoustics Sound Power Measured					
	Power in Watts	<300 W	≥300 W	≥600 W	≥1000 W
	Servers/Rack Mount BA	7.0	7.0	7.0	7.0

Note:

- Intel Corporation server boards contain a number of high-density VLSI and power delivery components that need adequate airflow to cool. Intel ensures through its own chassis development and testing that when Intel® server building blocks are used together, the fully integrated system will meet the intended thermal requirements of these components. It is the responsibility of the system

integrator who chooses not to use Intel® developed server building blocks to consult vendor datasheets and operating parameters to determine the amount of airflow required for their specific application and environmental conditions. Intel Corporation cannot be held responsible if components fail or the server board does not operate correctly when used outside any of its published operating or non-operating limits.

Disclaimer Note: Intel® ensures the unpackaged server board and system meet the shock requirement mentioned above through its own chassis development and system configuration. It is the responsibility of the system integrator to determine the proper shock level of the board and system if the system integrator chooses different system configuration or different chassis. Intel Corporation cannot be held responsible, if components fail or the server board does not operate correctly when used outside any of its published operating or non-operating limits.

6.2 System Environmental Testing

The system will be tested per the *Environmental Standards Handbook*, Intel Doc 25-GS0009. These tests shall include:

- Acoustic Sound Power
- Temperature operating and non-operating
- Humidity non-operating
- Shock Operating, Shock Packaged and Shock unpackaged
- Vibration Packaged and Vibration Unpackaged
- AC, DC, and I/O Surge
- AC voltage, frequency, and source interrupt
- Conducted Immunity
- DC Voltage and Source Interrupt
- Electrical Fast Transient (EFT)
- Electrostatic discharge (ESD)
- Flicker and Voltage Fluctuation
- Power Frequency Magnetic Fields
- Power Line Harmonics
- Radiated Emissions
- Radiated Immunity
- Telecom Power Line Conducted Emissions
- Voltage Dip and Dropout
- Reliability Test

Appendix A: Integration and Usage Tips

This appendix provides a list of useful information that is unique to the Intel® Server Chassis Union Peak Long family and should be kept in mind while integrating and configuring your server.

The Intel® Local Control Panel can only be used with systems configured with an Intel® Management Module.

Make sure the latest system software is loaded on the server. This includes system BIOS, FRU/SDR, BMC firmware, and hot-swap controller firmware. The latest system software can be downloaded from <http://www.intel.com/support/motherboards/server/>.

Glossary

Word/Acronym	Definition
ACA	Australian Communication Authority
ANSI	American National Standards Institute
ATA	Advanced Technology Attachment
ATX	Advanced Technology Extended
Auto-Ranging	Power supply that automatically senses and adjust itself to the proper input voltage range (110 VAC or 220 VAC). No manual switches or manual adjustments are needed.
BMC	Baseboard Management Controller
CFM	Cubic Feet per Minute (airflow)
CMOS	Complementary Metal Oxide Silicon
Dropout	A condition that allows the line voltage input to the power supply to drop to below the minimum operating voltage.
EEB	Entry-level Electronics Bay
EM	Expander Management
EMC	Electromagnetic compatibility
EMI	Electromagnetic Interference
EMP	Emergency Management Port
ESD	Electrostatic Discharge
FIT	Failures In Time
FP	Front Panel
FRB	Fault Resilient Booting
FRU	Field Replaceable Unit
GPIO	General Purpose Input and Output
HSBP	Hot-swap Backplane
I/O	Input/Output
I2C	Inter-Integrated Circuit
IPMB	Intelligent Platform Management Bus
IPMI	Intelligent Platform Management Interface
Latch Off	A power supply, after detecting a fault condition, shuts itself off. Even if the fault condition disappears, the supply does not restart unless manual or electronic intervention occurs. Manual intervention commonly includes briefly removing and then reconnecting the supply, or using a switch. Electronic intervention can be completed by electronic signals in the Server System.
LCD	Liquid Crystal Display
LCP	Local Control Panel
LPC	Low-Pin Count
LQFP	Lower Profile Quad Flat Pack
Monotonically	A waveform changes from one level to another in a steady fashion, without intermediate retrenchment or oscillation.
MTBF	Mean Time Between Failure
MTTR	Mean Time to Repair
Noise	The periodic or random signals over frequency band of 10 Hz to 20 MHz.

Word/Acronym	Definition
OCP	Over Current Protection
OTP	Over Temperature Protection
Over-current	A condition in which a supply attempts to provide more output current than the amount for which it is rated. This commonly occurs if there is a 'short circuit' condition in the load attached to the supply.
OVP	Over Voltage Protection
PDB	Power Distribution Board
PFC	Power Factor Correction
PMBus	Power Management Bus
PSU	Power Supply Unit
PWM	Pulse Width Modulate
ppm	Parts per million
PWOK	A typical logic level output signal provided by the supply that signals the Server System that all DC output voltages are within their specified range.
RI	Ring Indicate
Ripple	The periodic or random signals over frequency band of 10 Hz to 20 MHz.
Rise Time	The time it takes any output voltage to rise from 10% to 95% of its nominal voltage.
Sag	The condition where the AC line voltage drops below the nominal voltage conditions.
SAS	Serial Attached SCSI
SATA	Serial ATA
SCA	Single Connector Attachment
SCSI	Small Computer System Interface
SDK	Software Development Kit
SDR	Sensor Data Record
SE	Single-Ended
SES	SCSI Enclosure Service
SGPIO	Serial General Purpose Input/Output
SMBUS	System Management Bus
SSI	Server System Infrastructure
Surge	AC line voltage rises above nominal voltage
TACH	Tachometer
THD	Total Harmonic Distortion
UART	Universal Asynchronous Receiver Transmitter
USB	Universal Serial Bus
VCCI	Voluntary Control Council for Interference
VSB or Stand By	An output voltage that is present whenever AC power is applied to the AC inputs of the supply.

Reference Documents

See the following documents for additional information:

- *Intel® Server Board S2600IP and Intel® Workstation Board W2600CR Technical Product Specification*
- *Intel® Server System P4000IP and Intel® Workstation System P4000CR Service Guide*
- *Intel® Server System P4000IP and Intel® Workstation System P4000CR Quick Installation Guide*
- *BIOS for EPSD Platforms Based on Intel® Xeon Processor E5-4600/2600/2400/1600 Product Families External Product Specification*
- *EPSD Platforms Based On Intel Xeon® Processor E5 4600/2600/2400/1600 Product Families BMC Core Firmware External Product Specification*
- *Intel Integrated RAID Module RMS25PB080, RMS25PB040, RMS25CB080, and RMS25CB040 Hardware Users Guide*
- *Intel® Remote Management Module 4 Technical Product Specification*
- *Intel® Remote Management Module 4 and Integrated BMC Web Console Users Guide*