

Intel® Server Board S2600WP

Technical Product Specification

Intel order number G44057-003



Revision 1.2

June, 2012

Enterprise Platforms and Services Division - Marketing

Revision History

Date	Revision Number	Modifications
January 2012	1.0	Initial release
April 2012	1.1	<ul style="list-style-type: none"> ▪ Updated storage specification for all block diagrams. ▪ Added BMC Core Sensor list. ▪ Updated Shock (Unpackaged) data for <i>Server Board Design Specifications</i>. ▪ Updated Chassis Intrusion Information. ▪ Updated DDIO support information. ▪ Updated BIOS “shutdown policy” information.
June 2012	1.2	<ul style="list-style-type: none"> ▪ Added FDR InfiniBand* board information. ▪ Added NTB support in BIOS. ▪ Updated <i>Design Specifications</i> and <i>ASHRAE Specification</i>.

Disclaimers

Information in this document is provided in connection with Intel® products. No license, express or implied, by estoppel or otherwise, to any intellectual property rights is granted by this document. Except as provided in Intel®s Terms and Conditions of Sale for such products, Intel® assumes no liability whatsoever, and Intel® disclaims any express or implied warranty, relating to sale and/or use of Intel® products including liability or warranties relating to fitness for a particular purpose, merchantability, or infringement of any patent, copyright or other intellectual property right. Intel® products are not intended for use in medical, lifesaving, or life sustaining applications. Intel® may make changes to specifications and product descriptions at any time, without notice.

Designers must not rely on the absence or characteristics of any features or instructions marked “reserved” or “undefined”. Intel® reserves these for future definition and shall have no responsibility whatsoever for conflicts or incompatibilities arising from future changes to them.

This document contains information on products in the design phase of development. Do not finalize a design with this information. Revised information will be published when the product is available. Verify with your local sales office that you have the latest datasheet before finalizing a design.

This document may contain design defects or errors known as errata which may cause the product to deviate from published specifications. Current characterized errata are available on request.

This document and the software described in it are furnished under license and may only be used or copied in accordance with the terms of the license. The information in this manual is furnished for informational use only, is subject to change without notice, and should not be construed as a commitment by Intel Corporation. Intel Corporation assumes no responsibility or liability for any errors or inaccuracies that may appear in this document or any software that may be provided in association with this document.

Except as permitted by such license, no part of this document may be reproduced, stored in a retrieval system, or transmitted in any form or by any means without the express written consent of Intel Corporation.

Intel and Xeon are trademarks or registered trademarks of Intel Corporation.

*Other brands and names may be claimed as the property of others.

Copyright © Intel Corporation 2012. Portions Copyright © 2012 by LSI* Corporation and Mellanox* Corporation.

Table of Contents

1. Introduction	1
1.1 Section Outline	1
1.2 Server Board Use Disclaimer	2
2. Server Board Overview	3
2.1 Server Board Connector and Component Layout	4
2.1.1 Board Rear Connector Placement	5
2.1.2 Server Board Mechanical Drawings	6
3. Product Architecture Overview	7
3.1 High Level Product Features	7
3.2 Processor Support	9
3.2.1 Processor Socket Assembly	10
3.2.2 Processor Population Rules	11
3.3 Processor Function Overview	13
3.3.1 Intel® QuickPath Interconnect	14
3.3.2 Integrated Memory Controller (IMC) and Memory Subsystem	14
3.3.3 Processor Intergrated I/O Module (I/O)	20
3.4 Intel® C600-A PCH Functional Overview	24
3.4.1 PCI Express*	26
3.4.2 Non-Transparent Bridge	26
3.4.3 Universal Serial Bus (USB)	27
3.4.4 Serial Attached SCSI (SAS) and Serial ATA (SATA) Controller	27
3.4.5 PCI Interface	28
3.4.6 Low Pin Count (LPC) Interface	28
3.4.7 Digital Media Interface (DMI)	29
3.4.8 Serials Peripheral Interface (SPI)	29
3.4.9 Compatibility Modules (DMA Controller, Timer/Counters, Interrupt Controller)	29
3.4.10 Advanced Programmable Interrupt Controller (APIC)	29
3.4.11 Real Time Clock (RTC)	29
3.4.12 GPIO	30
3.4.13 Enhanced Power Management	30
3.4.14 Fan Speed Control	30
3.4.15 Intel® Virtualization Technology for Direct I/O (Intel® VT-d)	30
3.4.16 KVM/Serial Over LAN (SOL) Function	30
3.4.17 IDE-R Function	30
3.4.18 Manageability	31
3.4.19 System Management Bus (SMBus 2.0*)	31
3.4.20 Network Interface Controller (NIC)	32
3.5 InfiniBand* Controller	33
3.5.1 Device Interfaces	34

3.5.2	Quad Small Form-factor Pluggable (QSFP) connector	35
3.6	Integrated Baseboard Management Controller Overview	35
3.6.1	Super I/O Controller	37
3.6.2	Graphics Controller and Video Support	38
3.6.3	Remote KVM.....	39
4.	Platform Management Functional Overview.....	40
4.1	Baseboard Management Controller (BMC) Firmware Feature Support.....	40
4.1.1	IPMI 2.0 Features.....	40
4.1.2	Non IPMI Features	41
4.1.3	New Manageability Features	42
4.3	Advanced Configuration and Power Interface (ACPI)	44
4.4	Platform Management SMBus* and I ² C Implementation.....	44
4.5	BMC Internal Timestamp Clock.....	45
4.6	Sensor Monitoring	45
4.7	Messaging Interfaces	45
4.7.1	Channel Management.....	46
4.7.2	User Model.....	46
4.7.3	Sessions	47
4.7.4	BMC LAN Channels	48
4.7.5	IPV6 Support.....	49
4.8	System Event Log (SEL)	51
4.8.1	Servicing Events	51
4.8.2	SEL Entry Deletion.....	51
4.8.3	SEL Erasure.....	51
4.8.4	SEL Extension Capabilities	51
4.9	Sensor Data Record (SDR) Repository	52
4.10	Field Replaceable Unit (FRU) Inventory Device	52
4.11	Diagnostics and Beep Code Generation.....	52
4.12	Diagnostics Interrupt (NMI).....	53
4.13	BMC Basic and Advanced Management Features	53
4.13.1	Enabling Advanced Manageability Features.....	54
4.13.2	Media Redirection	56
4.13.3	Embedded Web server.....	57
4.13.4	Data Center Management Interface (DCMI)	59
4.13.5	Local Directory Authentication Protocol (LDAP)	59
4.13.6	Platform/Chassis Management	59
4.13.7	Thermal Control	60
4.13.8	Node Power On/Off Control.....	61
4.14	Intel® Intelligent Power Node Manager	61
4.14.1	Overview	61
4.14.2	Features.....	62

4.15	Management Engine (ME).....	62
4.15.1	Overview.....	62
4.15.2	BMC – Management Engine (ME) Distributed Model	62
4.15.3	ME System Management Bus (SMBus*) Interface	63
4.15.4	BMC - Management Engine Interaction.....	64
4.15.5	ME Power and Firmware Startup.....	64
4.15.6	SmaRT/CLST.....	64
4.16	Other Platform Management	65
4.16.1	Wake On LAN (WOL).....	65
4.16.2	PCI Express* Power management	65
4.16.3	PMBus*	65
4.16.4	Node Power Policies	65
5.	BIOS Setup Interface.....	67
5.1	HotKeys Supported During POST	67
5.2	POST Logo/Diagnostic Screen.....	67
5.3	BIOS Boot Pop-up Menu.....	68
5.4	BIOS Setup Utility	68
5.4.1	BIOS Setup Operation.....	68
5.4.2	BIOS Setup Utility Screens.....	72
5.5	Loading BIOS Defaults.....	124
6.	Configuration Jumpers	125
6.1.1	Force Integrated BMC Update (J6B1)	126
6.1.2	Force ME Update (J1E2)	127
6.1.3	Password Clear (J1E3)	127
6.1.4	BIOS Recovery Mode (J1E1)	128
6.1.5	Reset BIOS Settings (J1D5).....	129
7.	Connector/Header Locations and Pin-out	130
7.1	Power Connectors.....	130
7.2	System Management Headers	130
7.2.1	Intel® Remote Management Module 4 (Intel® RMM4 Lite) Connector.....	130
7.2.2	IPMB Header.....	130
7.3	Bridge Board Connector.....	130
7.4	Power Button.....	132
7.5	Reset Button	133
7.6	Chassis Identify Button.....	133
7.7	Power LED.....	133
7.8	System Status LED	133
7.9	Chassis ID LED.....	135
7.10	I/O Connectors	136
7.10.1	PCI Express* Connectors.....	136
7.10.2	VGA Connector	145

7.10.3	NIC Connectors.....	146
7.10.4	SATA Connectors	146
7.10.5	Hard Drive Activity (Input) LED Header	147
7.10.6	Storage Upgrade Key Connector.....	147
7.10.7	Serial Port Connectors	147
7.10.8	USB Connectors	148
7.10.9	QSFP for InfiniBand*	148
7.11	Fan Headers	149
7.12	Chassis Intrusion.....	149
8.	Intel® Light-Guided Diagnostics	150
8.1	Front Panel Support	150
8.1.1	System ID LED.....	150
8.1.2	System Status LED	150
8.1.3	Network Link/Activity LED	150
8.1.4	Dedicated InfiniBand* Link/Activity LED	151
8.2	POST Code Diagnostic LEDs.....	151
9.	Environmental Limits Specification	153
9.1	System Level Environmental Considerations.....	153
9.1.1	Set Throttling Mode	154
9.1.2	Altitude	154
9.1.3	Set Fan Profile	154
9.1.4	Fan PWM Offset.....	154
9.1.5	Quiet Fan Idle Mode.....	154
9.1.6	Thermal Sensor Input for Fan Speed Control	155
9.2	Processor Thermal Design Power (TDP) Support	156
10.	Power Supply Specification Guidelines.....	157
10.1	Power Supply DC Output Connector	157
10.2	Power Supply DC Output Specification	157
10.2.1	Output Power/Currents.....	157
10.2.2	Standby Output	157
10.2.3	Voltage Regulation	157
10.2.4	Dynamic Loading	158
10.2.5	Capacitive Loading.....	158
10.2.6	Grounding	158
10.2.7	Closed loop stability	158
10.2.8	Residual Voltage Immunity in Standby mode	158
10.2.9	Common Mode Noise.....	159
10.2.10	Soft Starting	159
10.2.11	Zero Load Stability Requirements	159
10.2.12	Hot Swap Requirements	159
10.2.13	Forced Load Sharing.....	159

10.2.14 Ripple/Noise.....	159
10.2.15 Timing Reuqirement.....	159
Appendix A: Integration and Usage Tips	161
Appendix B: Integrated BMC Sensor Tables.....	162
Product ID	178
IPMI Channel ID Assignments.....	179
Baseboard Specific Sensors	179
ACPI S3 Sleep State Support	180
Processor Support for Intel® Server Boards S2600WP	180
Supported Chassis	180
Chassis-specific sensors	181
Hot-plug fan support	181
Fan redundancy support.....	181
Fan domain definition	181
HSC Availability	182
Power unit and Power Supply support.....	182
Redundant Fans only for Intel® Server Chassis	182
Fan Fault LED support.....	182
Memory Throttling support.....	182
Power Control Sources.....	182
Appendix C: BIOS Sensors and SEL Data	183
Appendix D: POST Code LED Decoder	190
Appendix E: Video POST Code Errors	197
Glossary	201
Reference Documents	204

List of Figures

Figure 1. Intel® Server Board S2600WP (Base SKU)	3
Figure 2. Intel® Server Board S2600WPQ/S2600WPF Components	5
Figure 3. Rear Panel Connector Placement	5
Figure 4. Baseboard and Mounting Holes	6
Figure 5. Intel® Server Board S2600WPQ/S2600WPF Functional Block Diagram	8
Figure 6. Intel® Server Board S2600WP Functional Block Diagram	9
Figure 7. Processor Socket Assembly	10
Figure 8. Processor Socket ILM Variations	10
Figure 9. Processor with IMC Functional Block Diagram	14
Figure 10. Intel® Server Board S2600WP DIMM Slot Layout	18
Figure 11. General Functional Block Diagram of Processor I/O Sub-system	21
Figure 12. PCI Express* Lane distribution scheme	22
Figure 13. Legacy VGA Socket configuration in BIOS	22
Figure 14. PCIe Riser for Slot 1	23
Figure 15. PCIe Riser for Slot 2	24
Figure 16. Intel® C600-A PCH connection	25
Figure 17. 1GbE NIC port LED	32
Figure 18. ConnectX-3* function block diagram	34
Figure 19. Connection between Mellanox* ConnectX-3* and QSFP	35
Figure 20. Integrated BMC implementation overview	36
Figure 21. Integrated BMC Functional Block Diagram	36
Figure 22. Management Engine Distribution Model	63
Figure 23. Main Screen	75
Figure 24. Advanced Screen	77
Figure 25. Processor Configuration Screen	79
Figure 26. Power and Performance Configuration Screen	84
Figure 27. Memory Configuration Screen	87
Figure 28. Memory RAS and Performance Configuration Screen	89
Figure 29. Mass Storage Controller Configuration Screen	91
Figure 30. PCI Configuration Screen	92
Figure 31. NIC Configuration Screen	95
Figure 32. Serial Port Configuration Screen	102
Figure 33. USB Configuration Screen	103
Figure 34. System Acoustic and Performance Configuration	104
Figure 35. Security Screen	107
Figure 36. Server Management Screen	109
Figure 37. Console Redirection Screen	112
Figure 38. System Information Screen	113
Figure 39. BMC LAN Configuration Screen	115

Figure 40. Boot Options Screen	117
Figure 41. Hard Disk Order Screen	119
Figure 42. Network Device Order Screen.....	120
Figure 43. Delete EFI Boot Option Screen	120
Figure 44. Boot Manager Screen	121
Figure 45. Error Manager Screen.....	122
Figure 46. Exit Screen.....	123
Figure 47. Jumper Blocks (J6B1, J1E2, J1E3, J1E1, J1D5).....	125
Figure 48. Connectors on Bridge Board	131
Figure 49. System Status LED (A) and ID LED (B)	134
Figure 50. Rear Panel Diagnostic LEDs (Block A).....	152
Figure 51. Fan Speed Control Structure.....	155
Figure 52. Turn On/Off Timing (Power Supply Signals).....	160
Figure 53. Diagnostic LED Placement Diagram	190

List of Tables

Table 1. Intel® Server Board S2600WP Feature Set	3
Table 2. Intel® Server Board S2600WP Features	7
Table 3. Mixed Processor Configurations	12
Table 4. UDIMM Support Guidelines	16
Table 5. RDIMM Support Guidelines	16
Table 6. LRDIMM Support Guidelines	17
Table 7. Intel® Server Board S2600WP DIMM Nomenclature	18
Table 8. CPU1 and CPU2 PCIe Connectivity	22
Table 9. Intel® Server Board S2600WP SATA/SAS port	27
Table 10. Intel® RAID C600-A Storage Upgrade Key Options for S2600WP	28
Table 11. Network port configuration	34
Table 12. Video Modes	38
Table 13. Video mode	38
Table 14. ACPI Power States	44
Table 15. Standard Channel Assignments	46
Table 16. Default User Values	47
Table 17. Channel/Media-specific minimum number of sessions	47
Table 18. BMC Beep Codes	52
Table 19. NMI Signal Generation and Event Logging	53
Table 20. Basic and Advanced Management Features	53
Table 21. Management features and Benefits	54
Table 22. Fan Profile Mapping	60
Table 23. POST HotKeys Recognized	67
Table 24. BIOS Setup Page Layout	69
Table 25. BIOS Setup: Keyboard Command Bar	71
Table 26. Screen Map	73
Table 27. Setup Utility – Main Screen Fields	75
Table 28. Setup Utility – Advanced Screen Display Fields	77
Table 29. Setup Utility — Processor Configuration Screen Fields	80
Table 30. Setup Utility – Power and Performance Configuration Screen Fields	84
Table 31. Power/Performance Profiles	84
Table 32. Setup Utility – Memory Configuration Screen Fields	88
Table 33. Setup Utility – Memory RAS and Performance Configuration Fields	89
Table 34. Setup Utilities – Mass Storage Controller Configuration Fields	91
Table 35. Setup Utility – PCI Configuration Screen Fields	93
Table 36. Setup Utility – NIC Configuration Screen Fields	95
Table 37. Setup Utility – Serial Ports Configuration Screen Fields	102
Table 38. Setup Utility – USB Controller Configuration Screen Fields	103
Table 39. Setup Utility – System Acoustic and Performance Configuration Screen Fields	105

Table 40. Setup Utility – Security Configuration Screen Fields.....	108
Table 41. Setup Utility – Server Management Configuration Screen Fields.....	109
Table 42. Setup Utility – Console Redirection Configuration Fields.....	112
Table 43. Setup Utility – Server Management System Information Fields.....	113
Table 44. Setup Utility — BMC configuration Screen Fields.....	116
Table 45. Setup Utility – Boot Options Screen Fields.....	118
Table 46. Setup Utility — Hard Disk Order Fields.....	119
Table 47. Setup Utility — Network Device Order Fields.....	120
Table 48. Setup Utility – Delete Boot Option Fields.....	120
Table 49. Setup Utility – Boot Manager Screen Fields.....	121
Table 50. Setup Utility — Error Manager Screen Fields.....	122
Table 51. Setup Utility — Exit Screen Fields.....	123
Table 52. Server Board Jumpers (J6B1, J1E2, J1E3, J1E1, J1D5).....	125
Table 53. Force Integrated BMC Update Jumper.....	126
Table 54. Force ME Update Jumper.....	127
Table 55. Password Clear Jumper.....	127
Table 56. BIOS Recovery Mode Jumper.....	128
Table 57. Reset BIOS Jumper.....	129
Table 58. Main Power Supply Connector 6-pin 2x3 Connector (J4K1 and J3K1).....	130
Table 59. Intel® RMM4 Lite Connector Pin-out (J1A2).....	130
Table 60. IPMB Header 4-pin (J2D2).....	130
Table 61. Bridge Board Connector (J1D1).....	131
Table 62. Power LED Indicator States.....	133
Table 63. System Status LED.....	134
Table 64. Chassis ID LED Indicator States.....	135
Table 65. PCI Express* x16 IO Riser Slot 1 Connector (J6A1).....	136
Table 66. PCI Express* x16 Riser Slot 2 Connector (J1B2).....	138
Table 67. PCI Express* x16 Riser Slot 3 Connector (J1F1).....	140
Table 68. PCI Express* x16 Riser Slot 4 Connector (J1H1).....	143
Table 69. PCI Express* Riser ID Assignment.....	145
Table 70. VGA External Video Connector (J4A1).....	146
Table 71. RJ-45 10/100/1000 NIC Connector Pin-out (JA6A1, JA5A1).....	146
Table 72. SATA Connector.....	147
Table 73. SATA HDD Activity (Input) LED Header (J6C5).....	147
Table 74. Storage Upgrade Key Connector (J6C4).....	147
Table 75. Internal 9-pin Serial A (COM1) (J6A2).....	147
Table 76. External USB port Connector (J3A1).....	148
Table 77. Internal USB Connector (J2D1).....	148
Table 78. QSFP Pin Definition.....	148
Table 79. Baseboard Fan Connector (J1K2).....	149
Table 80. Chassis Intrusion Header (J6C1).....	149

Table 81. Network link/activity LED	151
Table 82. InfiniBand* link/activity LED	151
Table 83. Server Board Design Specifications	153
Table 84. Power Supply DC Power Output Connector Pinout	157
Table 85. Minimum Load Ratings.....	157
Table 86. Voltage Regulation Limits.....	158
Table 87. Transient Load Requirements	158
Table 88. Capacitive Loading Conditions	158
Table 89. Ripples and Noise	159
Table 90. Timing Requirements	160
Table 91. BMC Core Sensors for EPSP Platforms Based on Intel® Xeon® Processor E5 4600/2600/2400/1600 Product Families	164
Table 92. BMC Channels' Assignments	179
Table 93. Intel® Server Board S2600WP Voltage Sensors	179
Table 94. Intel® Server Board S2600WP Temperature Sensors.....	180
Table 95. Intel® Server Chassis H23XXWP and H22XXWP Specific Sensors.....	181
Table 96. Intel® Server Chassis H23XXWP and H22XXWP Fan Domain Definition.....	181
Table 97. Intel® Server Chassis H23XXWP and H22XXWP Power Supply Support	182
Table 98. BIOS Sensor and SEL Data	183
Table 99. POST Progress Code LED Example	191
Table 100. Diagnostic LED POST Code Decoder	192
Table 101. POST Error Messages and Handling.....	197
Table 102. Glossary	201

1. Introduction

The Intel® Server Board S2600WP is a half width, dual sockets server board using the Intel® Xeon® Processor E5-2600 series processor, in combination with Intel® C600-A chipset to provide an outstanding feature set for high performance and high density computing.

This Technical Product Specification (TPS) provides board-specific information detailing the features, functionality, and high-level architecture of the Intel® Server Boards S2600WP.

For design-level information of specific components or subsystems relevant to the server boards described in this document, additional documents can be obtained through Intel®. The following table lists documents used as reference to compile much of the data provided here. Some of the listed documents are not publically available and must be ordered through your local Intel® representative.

1.1 Section Outline

This document is divided into the following chapters:

- Chapter 1 – Introduction
- Chapter 2 – Server Board Overview
- Chapter 3 – Product Architecture Overview
- Chapter 4 – Platform Management Functional Overview
- Chapter 5 – BIOS Setup Interface
- Chapter 6 – Configuration Jumpers
- Chapter 7 – Connector/Header Location and Pin-out
- Chapter 8 – Intel® Light-Guided Diagnostics
- Chapter 9 – Environmental Limits Specifications
- Chapter 10 – Power Supply Specification Guidelines
- Appendix A – Integration and Usage Tips
- Appendix B – Integrated BMC Sensor Tables
- Appendix C – BIOS Sensors and SEL Data
- Appendix D – POST Code LED Decoder
- Appendix E – Video POST Code Errors
- Glossary
- Reference Documents

1.2 Server Board Use Disclaimer

Intel Corporation server boards contain a number of high-density VLSI and power delivery components that need adequate airflow to cool. Intel® ensures through its own chassis development and testing that when Intel® server building blocks are used together, the fully integrated system will meet the intended thermal requirements of these components. It is the responsibility of the system integrator who chooses not to use Intel® developed server building blocks to consult vendor datasheets and operating parameters to determine the amount of air flow required for their specific application and environmental conditions. Intel Corporation cannot be held responsible if components fail or the server board does not operate correctly when used outside any of their published operating or non-operating limits.

2. Server Board Overview

The Intel® Server Board S2600WP is a monolithic printed circuit board (PCB) with features designed to support the high performance and high density computing markets. This server board is designed to support the Intel® Xeon® processor E5-2600 product family. Previous generation Intel® Xeon® processors are not supported. Many of the features and functions of the server board family are common. A board will be identified by name when a described feature or function is unique to it.

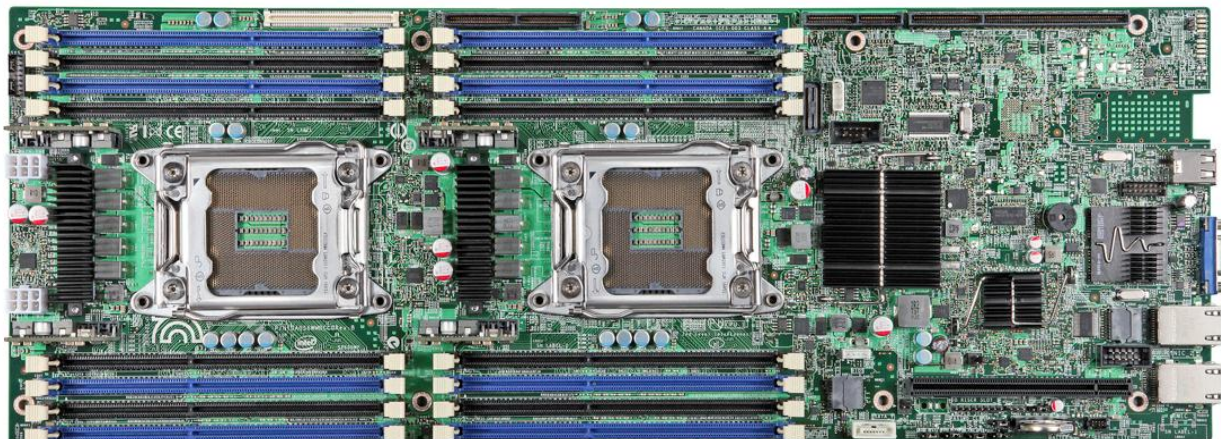

Figure 1. Intel® Server Board S2600WP (Base SKU)

There are three board SKUs based on different hardware configuration:

- **S2600WP**: base SKU
- **S2600WPQ**: base SKU with Mellanox* ConnectX-3* InfiniBand* QDR populated
- **S2600WPF**: base SKU with Mellanox* ConnectX-3* InfiniBand* FDR populated

The following table provides a high-level product feature list.

Table 1. Intel® Server Board S2600WP Feature Set

Feature	Description
Processors	Support for one or two Intel® Xeon® Processor E5-2600 series processors. <ul style="list-style-type: none"> ▪ Up to eight GT/s Intel® QuickPath Interconnect (Intel® QPI) ▪ LGA 2011 Socket R ▪ Thermal Design Power (TDP) up to 135 Watt (Intel® Server System H2000WP supports up to 130W TDP processors)
Memory	<ul style="list-style-type: none"> ▪ 16 DIMM slots total across eight memory channels ▪ Unbuffered or registered DDR3 with ECC DIMMs ▪ Memory DDR3 data transfer rates of 800/1066/1333/1600 MT/s ▪ Load Reduced DDR3 DIMM ▪ DDR3 standard I/O voltage of 1.5V(All Speed) and DDR3 Low Voltage of 1.35V (1333MT/s or below)
Chipset	Intel® C600-A Platform Controller Hub(PCH) with support for optional Storage Upgrade Key

Feature	Description
External I/O Connections	<ul style="list-style-type: none"> ▪ DB-15 Video connectors ▪ Two RJ-45 Network Interface for 10/100/1000 LAN ▪ One stacked two port USB 2.0 (Port 0/1) connectors ▪ One InfiniBand* QDR QSFP port (SKU: S2600WPQ only) ▪ One InfiniBand* FDR QSFP port (SKU: S2600WPF only)
Internal I/O connectors/headers	<ul style="list-style-type: none"> ▪ Bridge Slot to extend board I/O <ul style="list-style-type: none"> - SCU0 (Four SATA/SAS 3Gb/s ports) for backplane - Front control panel signals - One SATA(Port 0) 6Gb/s port for DOM ▪ One USB 2.0 connector (USB port 2/3) ▪ One 2x7pin header for system FAN module ▪ One DH-10 serial Port A connector ▪ One SATA 6Gb/s (Port 1) ▪ One 2x4 pin header for Intel® RMM4 Lite ▪ One 1x4 pin header for Storage Upgrade Key
Power Connections	Two sets of 2x3 pin connector
System Fan Support	Three sets of dual rotor fan
Add-in Riser Support	<p>Four PCIe Gen III riser slots</p> <ul style="list-style-type: none"> ▪ Riser slot 1 supports PCIe Gen III x16 Riser. ▪ Riser slot 2 of S2600WP supports one PCIe Gen III x16 Riser and one PCIe Gen III x8 Riser in one physical slot the same time or PCIe Gen III x8 Riser (for Intel® rIOM). ▪ Riser slot 2 of S2600WPQ and S2600WPF support PCIe Gen III x16 Riser or PCIe Gen III x8 Riser (for Intel® rIOM). <p>One Bridge Slot for board I/O expansion</p> <p>Note: With Intel's riser, the riser slot 2 supports Intel® rIOM only. It does not support other standard PCI-E adapters. Intel® rIOM is supported on Riser slot 2 only. Intel® Server System family H2000WP does not support PCIe riser slot 3 and slot 4.</p>
Video	<ul style="list-style-type: none"> ▪ Integrated 2D Video Graphics controller ▪ 128MB DDR3 Memory
Hard Drive Support	One SATA port at 6Gbps on board. Four SATA/SASports (from SCU0, SAS support need storage upgrade key) and one SATA 6Gbps port (for DOM) are supported through bridge board.
RAID Support	<ul style="list-style-type: none"> ▪ Intel® RSTe RAID 0/1/10/5 for SATA mode ▪ Intel® ESRT2 RAID 0/1/10/5 for SAS/SATA mode
Server Management	<ul style="list-style-type: none"> ▪ Onboard ServerEngines* LLC Pilot III* Controller ▪ Support for Intel® Remote Management Module 4 Lite solutions ▪ Intel® Light-Guided Diagnostics on field replaceable units ▪ Support for Intel® System Management Software ▪ Support for Intel® Intelligent Power Node Manager (Need PMBus*-compliant power supply)

2.1 Server Board Connector and Component Layout

The following illustration provides a general overview of the server board, identifying key feature and component locations. The majority of the items identified are common in the Intel® Server Board S2600WP family. The accompanying table will identify variations when present.

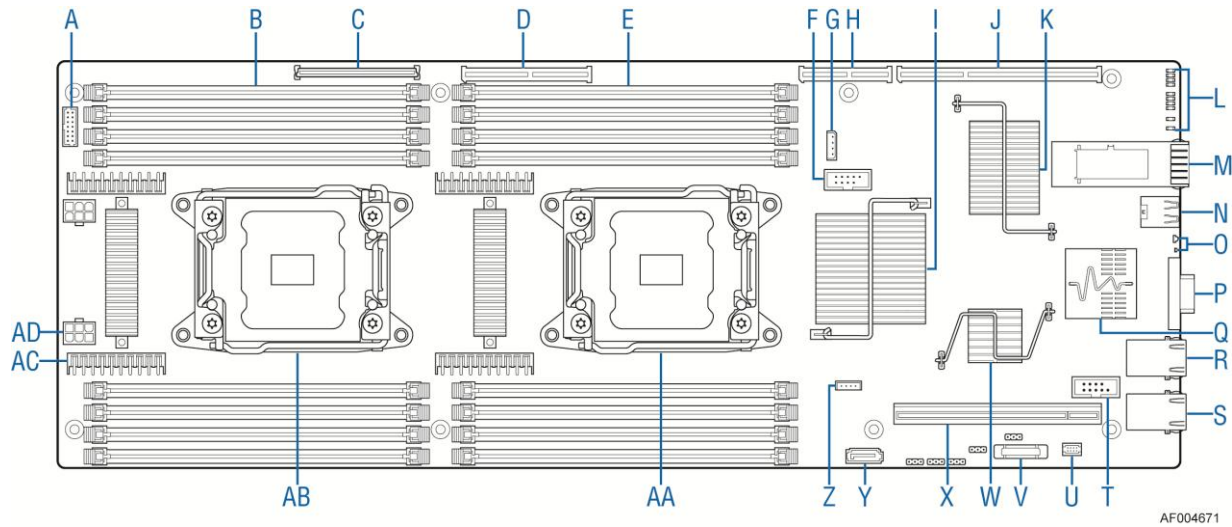

Description	Description	Description	Description
A 2x7 fan control connector	I PCH C600-A	Q Dual port 1GbE NIC chip	Y SATA port 1
B CPU2 DIMM (8 total)	J Riser Slot 2 (PCIe Gen3x16)	R NIC port 2	Z Storage Upgrade key
C Riser Slot 4 (PCIe Gen3x16)	K InfiniBand* QDR or FDR	S NIC Port 1	AA CPU 1
D Riser Slot 3 (PCIe Gen3x16)	L InfiniBand* diagnostic and status LED	T Serial Port A	AB CPU 2
E CPU1 DIMM (8 total)	M QSFP	U RMM4 lite	AC VRS (4 total)
F 2x5 USB	N USB x2	V CMOS battery	AD 2x3 PWR connector (2 total)
G IPMB connector	O Status and ID LED	W Integrated BMC	
H Bridge board connector	P VGA out	X Riser Slot 1 (PCIe Gen3x16)	

Figure 2. Intel® Server Board S2600WPQ/S2600WPF Components

2.1.1 Board Rear Connector Placement

The Intel® Server Board S2600WPQ has the following board rear connector placement:

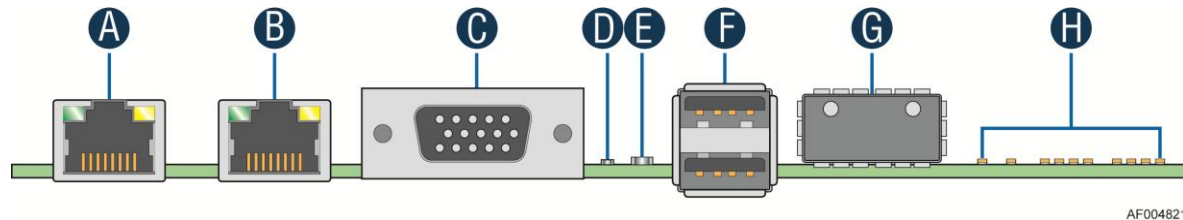

Description	Description
A NIC port 1 (RJ45)	E Status LED
B NIC port 2 (RJ45)	F Dual port USB connector
C DB15 video out	G QSFP Connector
D ID LED	H InfiniBand* diagnostic and status LED

Figure 3. Rear Panel Connector Placement

2.1.2 Server Board Mechanical Drawings

The following figure is the mechanical drawing of the Intel® Server Board S2600WP:

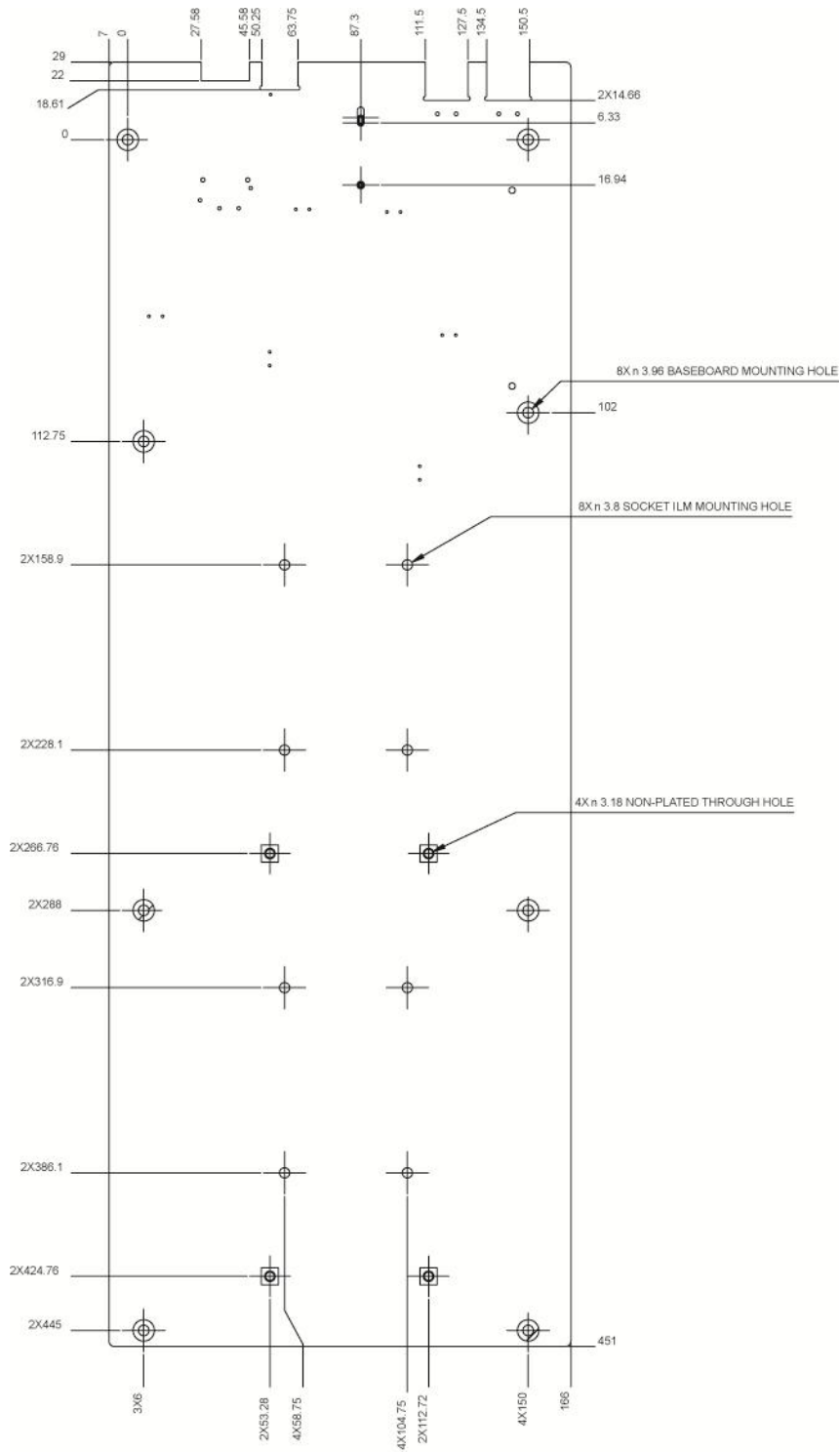

AF004831

Figure 4. Baseboard and Mounting Holes

3. Product Architecture Overview

The Intel® Server Board S2600WP is a purpose build, rack-optimized server board used in a high-density rack system. It is designed around the integrated features and functions of the Intel® Xeon® processor E5-2600 product family, the Intel® C600-A chipset, and other supporting components including the Integrated BMC, the Intel® I350 network interface controller and the Mellanox® ConnectX-3® InfiniBand® (depending on the board SKU).

The reduced board size allows four boards reside in a standard 2U Intel® Server Chassis H2000WP for high-performance and high-density computing.

3.1 High Level Product Features

Table 2. Intel® Server Board S2600WP Features

Board	S2600WP	S2600WPQ/S2600WPF
Form Factor	6.8" (173mm) x 18.9" (480mm)	
CPU Socket	Socket R, LGA2011	
Chipset	Intel® C600-A Chipset PCH	
Memory	16 DDR3 RDIMMs/LR-DIMMs/UDIMMs with ECC	
Slots	Three PCI Express* Gen3 x16 connectors One PCI Express* Gen3 x16 + x8 connector One system bridge board connector	4 PCI Express* Gen3 x16 connectors 1 system bridge board connector
Ethernet	Dual GbE, Intel® I350 Gigabit Ethernet	
InfiniBand*	N/A	Single port of InfiniBand* QDR/FDR
SATA Storage	One SATA III port (6Gb/s) on base board and One SATA III port (6Gb/s) on the bridge board	
SAS Storage	Four SAS ports (3Gb/s, on the backplane of server system H2000WP) from SCU0 through bridge board (The SAS support needs storage upgrade key).	
Software RAID	Intel® ESRT2 SAS/SATA RAID 0,1,5,10 or Intel® RSTe SATA RAID 0,1,5, and 10	
Processor Support	Maximum 135W TDP (Server System H2000WP supports 130W Maximum TDP CPUs)	
Video	Integrated in BMC	
iSMS	<ul style="list-style-type: none"> ▪ Onboard ServerEngines* LLC Pilot III* Controller with IPMI 2.0 support ▪ Support for Intel® Remote Management Module 4 Lite solutions ▪ Intel® Light-Guided Diagnostics on field replaceable units ▪ Support for Intel® System Management Software Support for Intel® Intelligent Power Node Manager (Need PMBus*-compliant power supply)	
Chassis	Intel® Server chassis H2000WP	
Power Supply	12V and 5VS/B PMBus*	

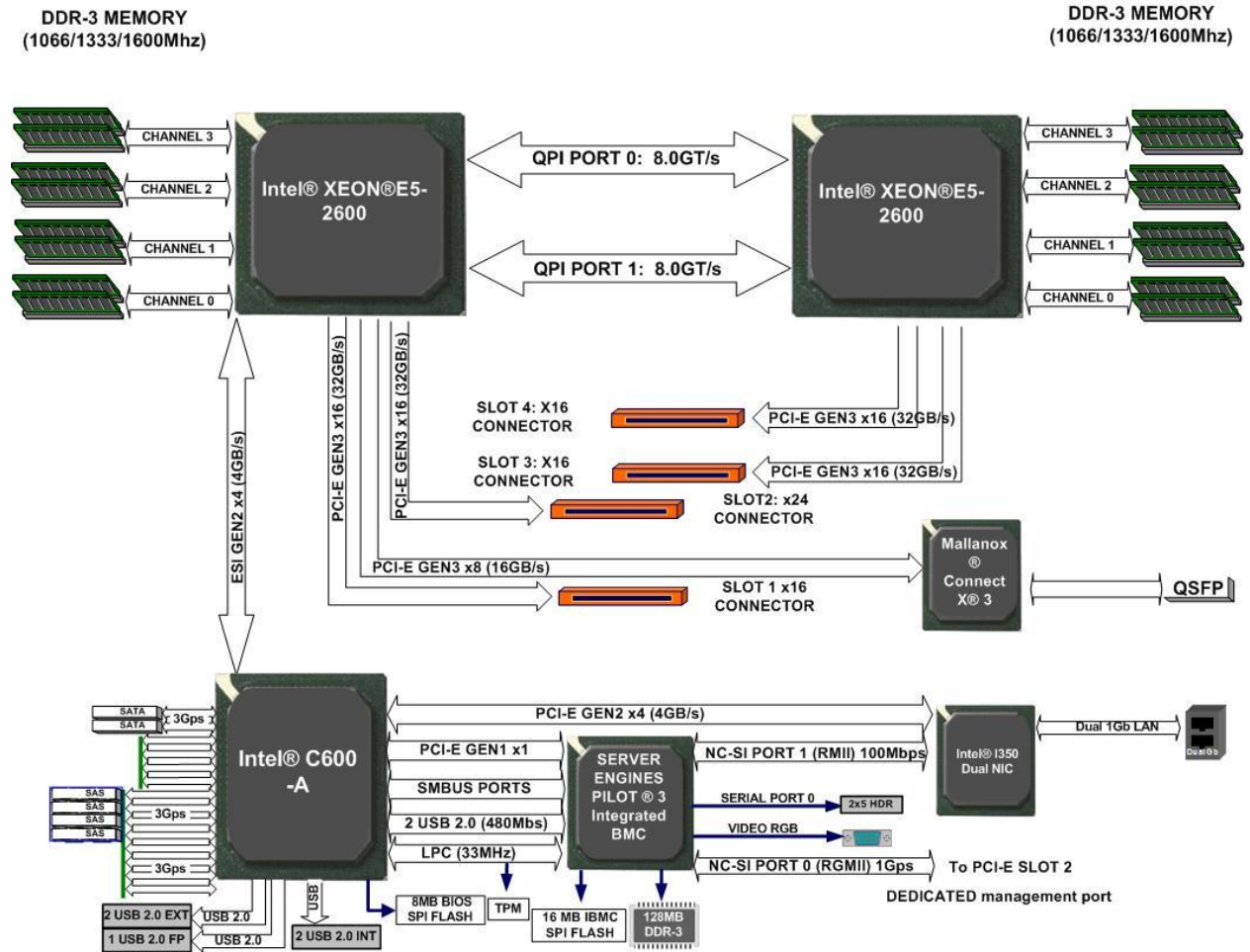

Figure 5. Intel® Server Board S2600WPQ/S2600WPF Functional Block Diagram

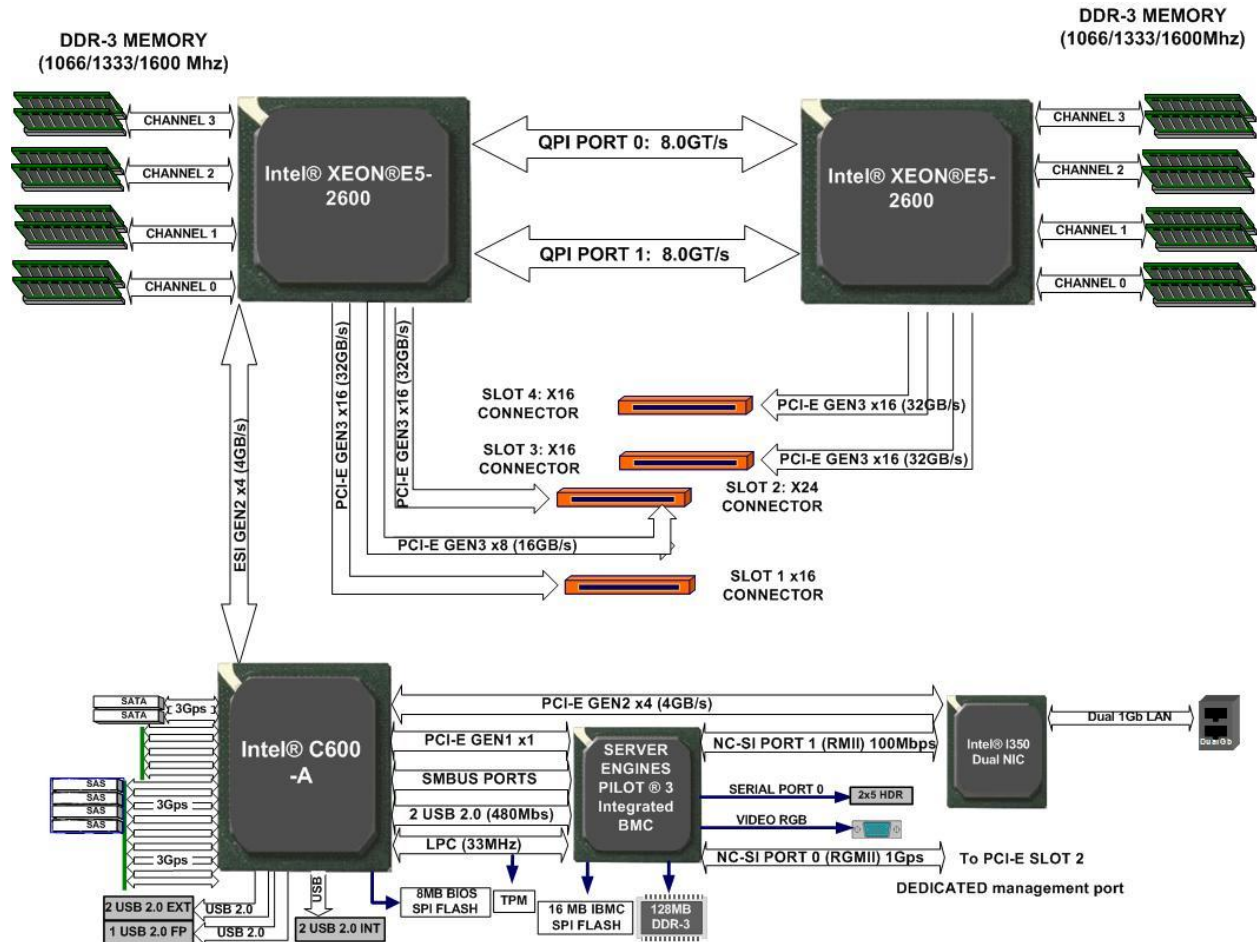

Figure 6. Intel® Server Board S2600WP Functional Block Diagram

3.2 Processor Support

The server board includes two Socket-R (LGA2011) processor sockets and can support Intel® Xeon® processor E5-2600 product family, code named “Sandy Bridge - EP” with a Thermal Design Power (TDP) of up to 135W.

The Intel® Xeon™ E5-2600 processor family are composed of 6/8 cores respectively. The microprocessors include an integrated DDR3 memory controller (IMC) with four memory channels which can support up to three ECC Registered DIMMs or three Un-buffered ECC DIMMs per memory channel, an integrated I/O controller with 40 PCI Express* Gen3 lanes controlled by ten PCI Express* Master Controllers. The target TDPs are: 50W, 60W, 70, 80W, 95W and 135W on Intel® Server Board S2600WP.

Previous generation Intel® Xeon® processors are **NOT** supported on the Intel® server boards described in this document.

For a complete updated list of supported processors, see:
http://www.intel.com/p/en_US/support/highlights/server/sb-s2600wp.

On the **Support** tab, look for **Compatibility** and then **Supported Processor List**.

3.2.1 Processor Socket Assembly

Each processor socket of the server board is pre-assembled with an Independent Latching Mechanism (ILM) and Back Plate which allow for secure placement of the processor and processor heat to the server board.

The illustration below identifies each sub-assembly component.

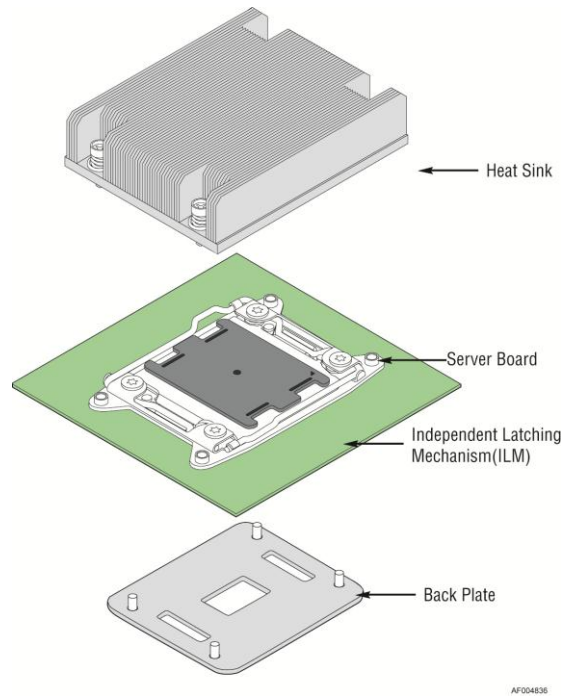

Figure 7. Processor Socket Assembly

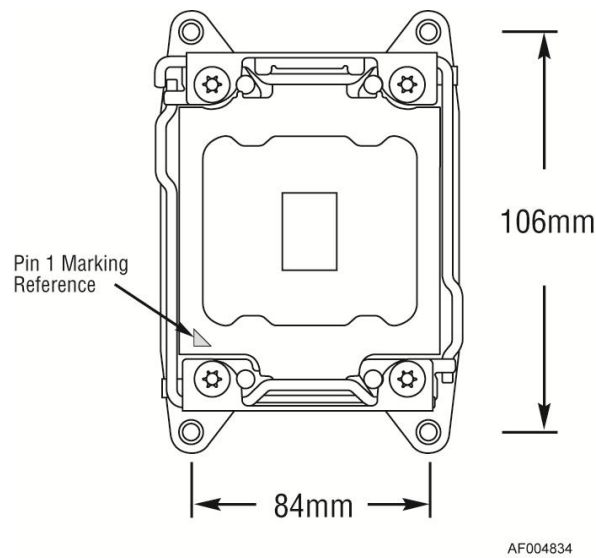

Figure 8. Processor Socket ILM Variations

The square ILM has an 84x106 mm heat sink mounting hole pattern and is used on the Intel® Server Board S2600WP.

Note: Intel® Server System H2000WP uses two different CPU heat sinks for CPU 1 and CPU 2. FXXCA84X106HS (Cu base-Al fin Heatsink) is for CPU1, while FXXE84X106HS (Al-extruded Heatsink) is for CPU2. Misallocating the heatsinks in Intel® server system H2000WP will cause serious thermal damage! Please refer *Intel® Server System H2000WP TPS* for more details.

3.2.2 Processor Population Rules

Note: Although the server board does support dual-processor configurations consisting of different processors that meet the defined criteria below, Intel® does not perform validation testing of this configuration. For optimal system performance in dual-processor configurations, Intel® recommends that identical processors be installed.

When using a single processor configuration, the processor must be installed into the processor socket labeled “CPU_1”.

When two processors are installed, the following population rules apply:

- Both processors must be of the same processor family.
- Both processors must have the same cache size.
- Processors with different speeds can be mixed in a system, given the prior rules are met. If this condition is detected, all processor speeds are set to the lowest common denominator (highest common speed) and an error is reported.
- Processor stepping within a common processor family can be mixed as long as it is listed in the processor specification updates published by Intel Corporation.

The following table describes mixed processor conditions and recommended actions for all Intel® server boards and Intel® server systems designed around the Intel® Xeon® Processor E5-2600 product family and Intel® C600-A chipset product family architecture. The errors fall into one of the following two categories:

- **Fatal:** If the system can boot, it goes directly to the Error Manager screen in BIOS Setup, regardless of whether the “Post Error Pause” setup option is enabled or disabled.

Major: If the “POST Error Pause” option in BIOS Setup is disabled, the system will log the error to the BIOS Setup Utility Error Manager and then continue to boot. No POST error message is given. If the “POST Error Pause” option in BIOS Setup is enabled, the error is logged and the system goes directly to the Error Manager in BIOS Setup.

Table 3. Mixed Processor Configurations

Error	Severity	System Action
Processor family not identical	Fatal	<p>The BIOS detects the error condition and responds as follows:</p> <ul style="list-style-type: none"> ▪ Logs the error into the system event log (SEL). ▪ Alerts the Integrated BMC of the configuration error with an IPMI command. ▪ Does not disable the processor. ▪ Displays “0194: Processor family mismatch detected” message in the error manager. ▪ Halts the system.
Processor cache not identical	Fatal	<p>The BIOS detects the error condition and responds as follows:</p> <ul style="list-style-type: none"> ▪ Logs the error into the SEL. ▪ Alerts the Integrated BMC of the configuration error with an IPMI command. ▪ Does not disable the processor. ▪ Displays “0192: Cache size mismatch detected” message in the error manager. ▪ Halts the system.
Processor frequency (speed) not identical	Major	<p>The BIOS detects the error condition and responds as follows:</p> <ul style="list-style-type: none"> ▪ Adjusts all processor frequencies to lowest common denominator. ▪ Continues to boot the system successfully. <p>If the frequencies for all processors cannot be adjusted to be the same, then the BIOS:</p> <ul style="list-style-type: none"> ▪ Logs the error into the SEL. ▪ Displays “0197: Processor speeds mismatched” message in the error manager. ▪ Halts the system.
Processor microcode missing	Fatal	<p>The BIOS detects the error condition and responds as follows:</p> <ul style="list-style-type: none"> ▪ Logs the error into the SEL. ▪ Alerts the Integrated BMC of the configuration error with an IPMI command. ▪ Does not disable processor. ▪ Displays “816x: Processor 0x unable to apply microcode update” message in the error manager. ▪ Pauses the system for user intervention.
Processor Intel® QuickPath Interconnect speeds not identical	Halt	<p>The BIOS detects the error condition and responds as follows:</p> <ul style="list-style-type: none"> ▪ Logs the error into the system event log (SEL). ▪ Alerts the Integrated BMC of the configuration error with an IPMI command. ▪ Does not disable the processor. ▪ Displays “0195: Processor Front Side Bus speed mismatch detected” message in the error manager. ▪ Halts the system.

When a single processor is installed, no terminator is required in the second processor socket.

3.3 Processor Function Overview

With the release of the Intel® Xeon® processor E5-2600 product family, several key system components, including the CPU, Integrated Memory Controller (IMC), and Integrated IO Module (IIO), have been combined into a single processor package and feature per socket; two Intel® QuickPath Interconnect point-to-point links capable of up to 8.0 GT/s, up to 40 lanes of Gen 3 PCI Express* links capable of 8.0 GT/s, and 4 lanes of DMI2/PCI Express* Gen 2 interface with a peak transfer rate of 5.0 GT/s. The processor supports up to 46 bits of physical address space and 48-bit of virtual address space.

The following sections will provide an overview of the key processor features and functions that help to define the performance and architecture of the server board. For more comprehensive processor specific information, refer to the Intel® Xeon® processor E5-2600 product family documents through <http://www.intel.com/content/www/us/en/processors/xeon/xeon-processor-5000-sequence.html>.

Processor Feature Details:

- Up to eight execution cores
- Each core supports two threads (Intel® Hyper-Threading Technology), up to 16 threads per socket
- 46-bit physical addressing and 48-bit virtual addressing
- 1GB large page support for server applications
- A 32KB instruction and 32KB data first-level cache (L1) for each core
- A 256KB shared instruction/data mid-level (L2) cache for each core
- Up to 20MB last level cache (LLC): up to 2.5MB per core instruction/data last level cache (LLC), shared among all cores

Supported Technologies:

- Intel® Virtualization Technology (Intel® VT)
- Intel® Virtualization Technology for Directed I/O (Intel® VT-d)
- Intel® Virtualization Technology “Sandy Bridge” Processor Extensions
- Intel® Trusted Execution Technology (Intel® TXT)
- Intel® 64 Architecture
- Intel® Streaming SIMD Extensions 4.1 (Intel® SSE4.1)
- Intel® Streaming SIMD Extensions 4.2 (Intel® SSE4.2)
- Intel® Advanced Vector Extensions (Intel® AVX)
- Intel® Hyper-Threading Technology
- Execute Disable Bit
- Intel® Turbo Boost Technology
- Intel® Intelligent Power Technology
- Enhanced Intel® SpeedStep Technology
- Data Direct I/O (DDIO)
- Non-Transparent Bridge (NTB)

3.3.1 Intel® QuickPath Interconnect

The Intel® QuickPath Interconnect is a high speed, packetized, point-to-point interconnect used in the processor. The narrow high-speed links stitch together processors in distributed shared memory and integrated I/O platform architecture. It offers much higher bandwidth with low latency. The Intel® QuickPath Interconnect has an efficient architecture allowing more interconnect performance to be achieved in real systems. It has a snoop protocol optimized for low latency and high scalability, as well as packet and lane structures enabling quick completions of transactions. Reliability, availability, and serviceability features (RAS) are built into the architecture.

The physical connectivity of each interconnect link is made up of twenty differential signal pairs plus a differential forwarded clock. Each port supports a link pair consisting of two unidirectional links to complete the connection between two components. This supports traffic in both directions simultaneously. To facilitate flexibility and longevity, the interconnect is defined as having five layers: Physical, Link, Routing, Transport, and Protocol.

The Intel® QuickPath Interconnect includes a cache coherency protocol to keep the distributed memory and caching structures coherent during system operation. It supports both low-latency source snooping and a scalable home snoop behavior. The coherency protocol provides for direct cache-to-cache transfers for optimal latency.

3.3.2 Integrated Memory Controller (IMC) and Memory Subsystem

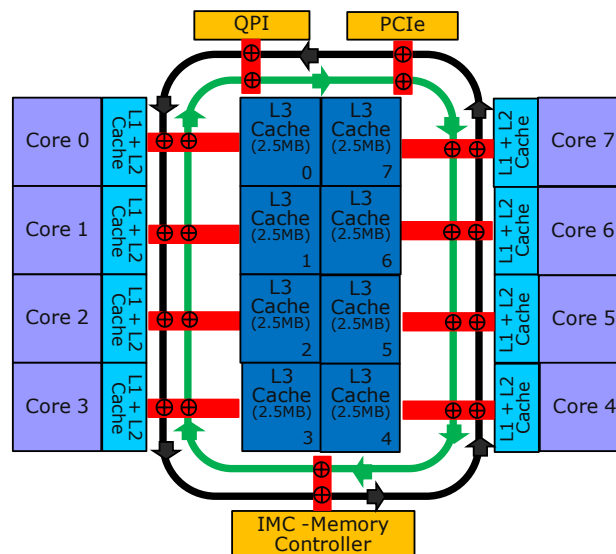

Figure 9. Processor with IMC Functional Block Diagram

- Unbuffered or registered DDR3 DIMMs
- LR DIMM (Load Reduced DIMM) for buffered memory solutions demanding higher capacity memory subsystems
- Independent channel mode or lockstep mode
- Data burst length of eight cycles for all memory organization modes
- Memory DDR3 data transfer rates of 800, 1066, 1333, and 1600 MT/s

- 64-bit wide channels plus 8-bits of ECC support for each channel
- DDR3 standard I/O Voltage of 1.5 V and DDR3 Low Voltage of 1.35 V
- 1-Gb, 2-Gb, and 4-Gb DDR3 DRAM technologies supported for these devices:
 - UDIMM DDR3 – SR x8 and x16 data widths, DR – x8 data width
 - RDIMM DDR3 – SR, DR, and QR – x4 and x8 data widths
 - LRDIMM DDR3 – QR – x4 and x8 data widths with direct map or with rank multiplication
- Up to eight ranks supported per memory channel, 1, 2 or 4 ranks per DIMM
- Open with adaptive idle page close timer or closed page policy
- Per channel memory test and initialization engine can initialize DRAM to all logical zeros with valid ECC (with or without data scrambler) or a predefined test pattern
- Isochronous access support for Quality of Service (QoS)
- Minimum memory configuration: independent channel support with 1 DIMM populated
- Integrated dual SMBus* master controllers
- Command launch modes of 1n/2n
- RAS Support:
 - Rank Level Sparing and Device Tagging
 - Demand and Patrol Scrubbing
 - DRAM Single Device Data Correction (SDDC) for any single x4 or x8 DRAM device. Independent channel mode supports x4 SDDC. x8 SDDC requires lockstep mode
 - Lockstep mode where channels 0 and 1 and channels 2 and 3 are operated in lockstep mode
 - Data scrambling with address to ease detection of write errors to an incorrect address.
 - Error reporting through Machine Check Architecture
 - Read Retry during CRC error handling checks by iMC
 - Channel mirroring within a socket
 - CPU1 Channel Mirror Pairs (A,B) and (C,D)
 - CPU2 Channel Mirror Pairs (E,F) and (G,H)
 - Error Containment Recovery
- Improved Thermal Throttling with dynamic Closed Loop Thermal Throttling (CLTT)
- Memory thermal monitoring support for DIMM temperature
- Supported Memory

Table 4. UDIMM Support Guidelines

Ranks Per DIMM and Data Width	Memory Capacity Per DIMM			Speed (MT/s) and Voltage Validated by Slot Per Channel (SPC) and DIMM Per Channel (DPC)			
				2 Slots Per Channel			
				1DPC		2DPC	
				1.35V	1.5V	1.35V	1.5V
SRx8 ECC	1GB	2GB	4GB	1066, 1333	1066, 1333	1066	1066, 1333
DRx8 ECC	2GB	4GB	8GB	1066, 1333	1066, 1333	1066	1066, 1333

Notes:

1. Supported DRAM Densities are 1Gb, 2Gb, and 4Gb. Only 2Gb, and 4Gb are validated by Intel®.
2. Command Address Timing is 1N for 1DPC and 2N for 2DPC.

Table 5. RDIMM Support Guidelines

Ranks Per DIMM and Data Width	Memory Capacity Per DIMM			Speed (MT/s) and Voltage Validated by Slot Per Channel (SPC) and DIMM Per Channel (DPC)			
				2 Slots Per Channel			
				1DPC		2DPC	
				1.35V	1.5V	1.35V	1.5V
SRx8	1GB	2GB	4GB	1066, 1333	1066, 1333, 1600	1066, 1333	1066, 1333, 1600
DRx8	2GB	4GB	8GB	1066, 1333	1066, 1333, 1600	1066, 1333	1066, 1333, 1600
SRx4	2GB	4GB	8GB	1066, 1333	1066, 1333, 1600	1066, 1333	1066, 1333, 1600
DRx4	4GB	8GB	16GB	1066, 1333	1066, 1333, 1600	1066, 1333	1066, 1333, 1600
QRx4	8GB	16GB	32GB	800	1066	800	800
QRx8	4GB	8GB	16GB	800	1066	800	800

Notes:

1. Supported DRAM Densities are 1Gb, 2Gb, and 4Gb. Only 2Gb and 4Gb are validated by Intel®.
2. Command Address Timing is 1N.
3. QR RDIMM are supported but only validated by Intel® in a homogenous environment. The coverage will have limited system level testing, no signal integrity testing, and no interoperability testing. The passing QR RDIMMs will be web posted.

Table 6. LRDIMM Support Guidelines

Ranks Per DIMM and Data Width	Memory Capacity Per DIMM		Speed (MT/s) and Voltage Validated by Slot Per Channel (SPC) and DIMM Per Channel (DPC)	
			2 Slots Per Channel	
			1DPC and 2DPC	
			1.35V	1.5V
QRx4 (DDP)	16GB	32GB	1066	1066, 1333
QRx8 (P)	8GB	16GB	1066	1066, 1333

Notes:

1. Physical Rank is used to calculate DIMM Capacity.
2. Supported and validated DRAM Densities are 2Gb and 4Gb.
3. Command Address Timing is 1N.
4. For 3SPC/3DPC - Rank Multiplication (RM) >= 2.
5. DDP - Dual Die Package DRAM stacking. P – Planer monolithic DRAM Die.

3.3.2.1 Memory population rules

Note: Although mixed DIMM configurations are supported, Intel® only performs platform validation on systems that are configured with identical DIMMs installed.

Each processor provides four banks of memory, each capable of supporting up to three DIMMs.

- DIMMs are organized into physical slots on DDR3 memory channels that belong to processor sockets.
- The memory channels from processor socket 1 are identified as Channel A, B, C and D. The memory channels from processor socket 2 are identified as Channel E, F, G, and H.
- The silk screened DIMM slot identifiers on the board provide information about the channel, and therefore the processor to which they belong. For example, DIMM_A1 is the first slot on Channel A on processor 1; DIMM_A2 is the second slot on Channel A on processor 1; DIMM_E1 is the first DIMM socket on Channel E on processor 2; DIMM_E2 is the second DIMM socket on Channel E on processor 2.
- The memory slots associated with a given processor are unavailable if the corresponding processor socket is not populated.
- A processor may be installed without populating the associated memory slots provided a second processor is installed with associated memory. In this case, the memory is shared by the processors. However, the platform suffers performance degradation and latency due to the remote memory.

- Processor sockets are self-contained and autonomous. However, all memory subsystem support (such as Memory RAS, Error Management,) in the BIOS setup are applied commonly across processor sockets.

On the Intel® Server Board S2600WP, a total of 16 DIMM slots is provided (two CPUs, four Channels/CPU, and two DIMMs/Channel). The nomenclature for DIMM sockets is detailed in the following table:

Table 7. Intel® Server Board S2600WP DIMM Nomenclature

Processor Socket 1				Processor Socket 2			
(0) Channel A	(1) Channel B	(2) Channel C	(3) Channel D	(0) Channel E	(1) Channel F	(2) Channel G	(3) Channel H
A1	B1	C1	D1	E1	F1	G1	H1
A2	B2	C2	D2	E2	F2	G2	H2

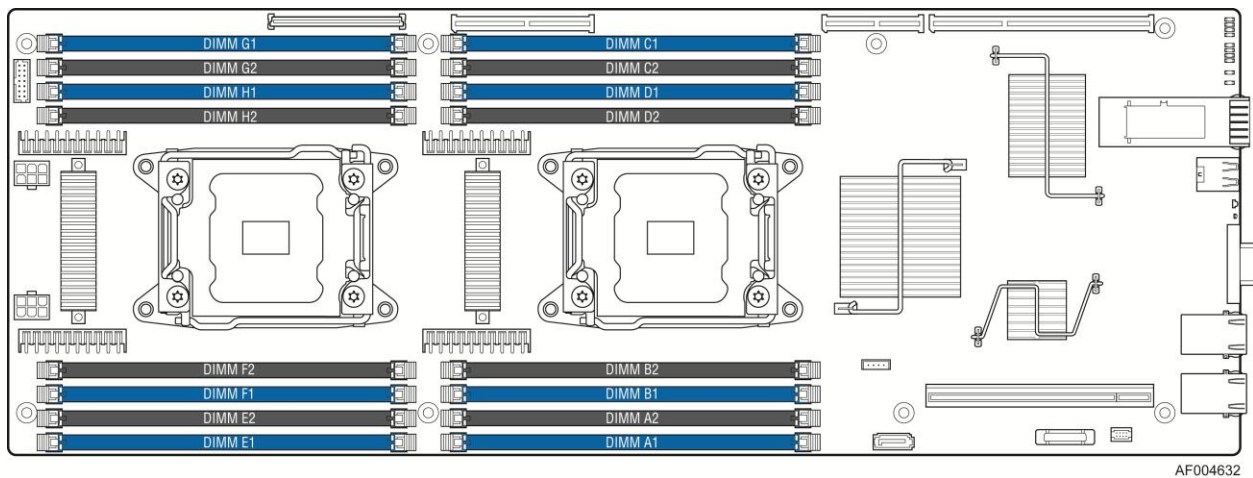

Figure 10. Intel® Server Board S2600WP DIMM Slot Layout

The following are generic DIMM population requirements that generally apply to the Intel® Server Board S2600WP.

- All DIMMs must be DDR3 DIMMs
- Unbuffered DIMMs should be ECC.
- Mixing of Registered and Unbuffered DIMMs is not allowed per platform.
- Mixing of LRDIMM with any other DIMM type is not allowed per platform.
- Mixing of DDR3 voltages is not validated within a socket or across sockets by Intel®. If 1.35V (DDR3L) and 1.50V (DDR3) DIMMs are mixed, the DIMMs will run at 1.50V.
- Mixing of DDR3 operating frequencies is not validated within a socket or across sockets by Intel®. If DIMMs with different frequencies are mixed, all DIMMs will run at the common lowest frequency.
- Quad rank RDIMMs are supported but not validated by Intel®.
- A maximum of 8 logical ranks (ranks seen by the host) per channel is allowed.
- Mixing of ECC and non-ECC DIMMs is not allowed per platform.

3.3.2.2 Publishing System Memory

- The BIOS displays the “Total Memory” of the system during POST if Display Logo is disabled in the BIOS setup. This is the total size of memory discovered by the BIOS during POST, and is the sum of the individual sizes of installed DDR3 DIMMs in the system.
- The BIOS displays the “Effective Memory” of the system in the BIOS setup. The term *Effective Memory* refers to the total size of all DDR3 DIMMs that are active (not disabled) and not used as redundant units.
- The BIOS provides the total memory of the system in the main page of the BIOS setup. This total is the same as the amount described by the first bullet above.
- If Display Logo is disabled, the BIOS displays the total system memory on the diagnostic screen at the end of POST. This total is the same as the amount described by the first bullet above.

3.3.2.3 RAS Features

The server board supports the following memory RAS modes:

- Independent Channel Mode
- Rank Sparing Mode
- Mirrored Channel Mode
- Lockstep Channel Mode

Regardless of RAS mode, the requirements for populating within a channel given in the section 3.3.2.1 must be met at all times. Note that support of RAS modes that require matching DIMM population between channels (Mirrored and Lockstep) require that ECC DIMMs be populated. Independent Channel Mode is the only mode that supports non-ECC DIMMs in addition to ECC DIMMs.

For RAS modes that require matching populations, the same slot positions across channels must hold the same DIMM type with regards to size and organization. DIMM timings do not have to match but timings will be set to support all DIMMs populated (that is, DIMMs with slower timings will force faster DIMMs to the slower common timing modes).

3.3.2.3.1 *Independent Channel Mode*

Channels can be populated in any order in Independent Channel Mode. All four channels may be populated in any order and have no matching requirements. All channels must run at the same interface frequency but individual channels may run at different DIMM timings (RAS latency, CAS Latency, and so forth).

3.3.2.3.2 *Rank Sparing Mode*

In Rank Sparing Mode, one rank is a spare of the other ranks on the same channel. The spare rank is held in reserve and is not available as system memory. The spare rank must have identical or larger memory capacity than all the other ranks (sparing source ranks) on the same channel. After sparing, the sparing source rank will be lost.

3.3.2.3.3 *Mirrored Channel Mode*

In Mirrored Channel Mode, the memory contents are mirrored between Channel 0 and Channel 2 and also between Channel 1 and Channel 3. As a result of the mirroring, the total physical memory available to the system is half of what is populated. Mirrored Channel Mode requires that Channel 0 and Channel 2, and Channel 1 and Channel 3 must be populated identically with regards to size and organization. DIMM slot populations within a channel do not have to be identical but the same DIMM slot location across Channel 0 and Channel 2 and across Channel 1 and Channel 3 must be populated the same.

3.3.2.3.4 *Lockstep Channel Mode*

In Lockstep Channel Mode, each memory access is a 128-bit data access that spans Channel 0 and Channel 1, and Channel 2 and Channel 3. Lockstep Channel mode is the only RAS mode that allows SDDC for x8 devices. Lockstep Channel Mode requires that Channel 0 and Channel 1, and Channel 2 and Channel 3 must be populated identically with regards to size and organization. DIMM slot populations within a channel do not have to be identical but the same DIMM slot location across Channel 0 and Channel 1 and across Channel 2 and Channel 3 must be populated the same.

3.3.3 Processor Intergrated I/O Module (I/O)

The processor's integrated I/O module provides features traditionally supported through chipset components. The integrated I/O module provides the following features:

- **PCI Express* Interfaces:** The integrated I/O module incorporates the PCI Express* interface and supports up to 40 lanes of PCI Express*. Following are key attributes of the PCI Express* interface:
 - Gen3 speeds at 8 GT/s (no 8b/10b encoding)
 - X16 interface bifurcated down to two x8 or four x4 (or combinations)
 - X8 interface bifurcated down to two x4
- **DMI2 Interface to the PCH:** The platform requires an interface to the legacy Southbridge (PCH) which provides basic, legacy functions required for the server platform and operating systems. Since only one PCH is required and allowed for the system, any sockets which do not connect to PCH would use this port as a standard x4 PCI Express* 2.0 interface.
- **Integrated IOAPIC:** Provides support for PCI Express* devices implementing legacy interrupt messages without interrupt sharing.
- **Non Transparent Bridge:** PCI Express* non-transparent bridge (NTB) acts as a gateway that enables high performance, low overhead communication between two intelligent subsystems; the local and the remote subsystems. The NTB allows a local processor to independently configure and control the local subsystem, provides isolation of the local host memory domain from the remote host memory domain while enabling status and data exchange between the two domains.
- **Intel® QuickData Technology:** Used for efficient, high bandwidth data movement between two locations in memory or from memory to I/O.



Figure 11. General Functional Block Diagram of Processor I/O Sub-system

The following sub-sections will describe the server board features that are directly supported by the processor I/O module. These include the Riser Card Slots, Network Interface, and connectors for the optional I/O modules and SAS Module. Features and functions of the Intel® C600-A Series chipset will be described in its own dedicated section.

3.3.3.1 Riser Card Support

The server board provides four riser card slots identified by Riser Slot 1, Riser Slot 2, Riser Slot 3 and Riser Slot 4. The PCIe signals for each riser card slot are supported by each of the two installed processors.

All lanes routed to Riser Slot 1 and Riser Slot 2 are from CPU 1. All lanes routed to Riser Slot 3 and Riser Slot 4 are from CPU 2.

Intel® server system H2000WP does not provide risers for Riser slot 3 and slot 4.

With Intel® riser card, the riser slot 2 can be used for rIOM only.

Below is the scope of I/O connection from processors on Intel® Server Board S2600WPQ/S2600WPF.

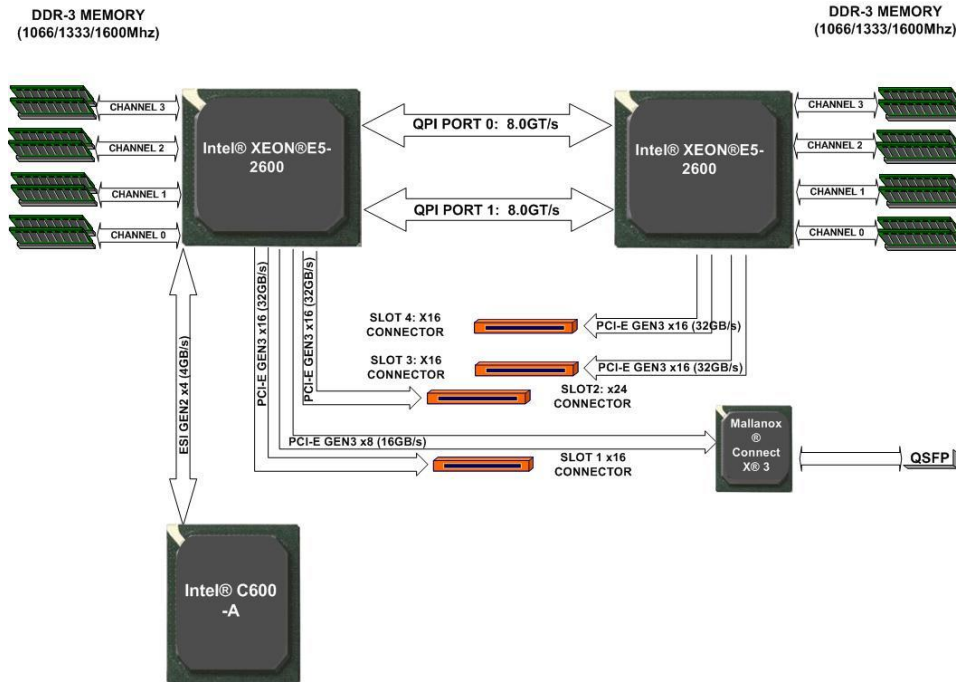

Figure 12. PCI Express* Lane distribution scheme

Table 8. CPU1 and CPU2 PCIe Connectivity

CPU	Port	IOU	Width	Connection
CPU1	DMI2	IOU2	x4	PCH (lane reversal, no polarity inversion)
CPU1	PE1	IOU2	X8	QDR/FDR InfiniBand*
CPU1	PE2	IOU0	x16	Riser 1
CPU1	PE3	IOU1	x16	Riser 2 (x8 for IOM on Riser)
CPU2	DMI2	IOU2	x4	Unused
CPU2	PE1	IOU2	x8	Unused
CPU2	PE2	IOU0	x16	Riser 3
CPU2	PE3	IOU1	x16	Riser 4

Note: Riser Slot 3 and slot 4 can only be used in dual processor configurations. With dual processor configurations even there's add-in graphic card in PCI slot, the default video output is still from on-board integrated BMC till users enable "dual monitor Video" in BIOS . Users need to determine whether Legacy VGA video output is enabled for PCIe slots attached to Processor Socket 1(PCle slot 1 and slot 2) or 2(PCle slot 3 and slot 4). Socket 1 is the default. You can change "legacy VGA socket" in BIOS setup interface from default "CPU socket 1" to "CPU socket 2" to enable video output through add-in graphic card which is in Riser slot 3 or 4.

Onboard Video	Enabled / Disabled
Legacy VGA Socket	CPU Socket 1/CPU Socket 2
Dual Monitor Video	Enabled / Disabled

Figure 13. Legacy VGA Socket configuration in BIOS

3.3.3.2 Riser Types

The riser slot 1 connector is a standard 164-pin x16 connector.

On S2600WP, the riser slot 2 has a x16 PCIe Gen 3 and a x8 PCIe Gen 3 electrical interface in the physical slot. On S2600WPQ and S2600WPF, the riser slot 2 has a x16 PCIe Gen 3 electrical interface. Riser slot 2 connector supports rIOM mounted on a riser carrier. This riser slot 2 connector supports RGMII (Reduced Gigabit Media Independent Interface) for the dedicated server management Ethernet port on the rIOM carrier. Intel® server system H2000WP provides 1x16 PCIe Gen 3 riser (x8 for IOM on Riser) for Riser slot 2.

Riser3 and riser4 are both customized slots which support 1x16 PCIe Gen3.

Customers can use Riser ID to configure all 4 riser slots to 1x16 PCI Gen 3 port or 2x8 PCI Gen 3 ports.

Riser ID	Configuration
1	1x16
0	2x8

The placement of the rear IO connectors and layout of the components on the board must be made to support a MD2, low profile card in the Riser1 and a rIOM mounted on a riser carrier for Riser 2. Riser 3 and 4 on S2600WP support off-board standard full height, full length I/O cards including double wide GPU boards.

To support GPU boards, each riser need to provide 66W of 12V power as well as 10W of 3.3V power In the case of 2 x8 boards being hosted in customized chassis. These risers need to generate 20W of 3.3V, the number of 12amp pins on the riser have increased to accommodate this.

Intel® server system H2000WP supports 1U riser cards include:

- 1U Riser for slot 1 with one PCIe slot – x16 signals routed to a x16 PCIe Slot.

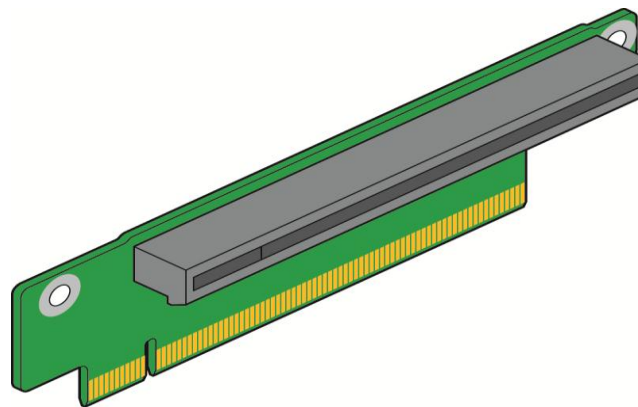

AF004224

Figure 14. PCIe Riser for Slot 1

- 1U Riser for Slot 2 with one PCIe slot – 2 sets of x8 signals routed to a x16 PCIe Slot (8 lanes for rIOM Carrier). This riser does not support standard PCI-E add-in adapters but

Intel® rIOM Carrier. Please refer *Intel® server system H2000WP Technical Production Specification* for details of rIOM Carrier.

- 1U customized Riser for Slot 2 with one PCIe slot – 1 set of x8 signals routed to root port 3A of processor 1 to facilitate Non-Transparent Bridge.

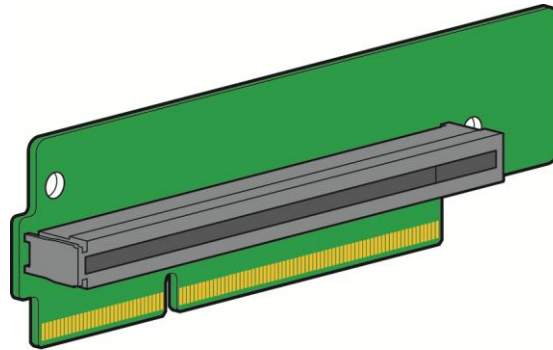

AF004645

Figure 15. PCIe Riser for Slot 2

3.3.3.3 Network Interface

Network connectivity from processor is provided by means of an onboard Mellanox* ConnectX-3* InfiniBand* Controller. **S2600WPQ** provides one SDR/DDR/QDR InfiniBand* port in a QSFP interface. S2600WPF provides one SDR/DDR/QDR/FDR InfiniBand* port in a QSFP interface. The Controller is supported by implementing x8 PCIe Gen3 signals from the I/O module of the CPU 1 processor. The on board Intel® i350 Ethernet controller provide two 10/100/1000Gbps Ethernet ports in two RJ45 ports on both S2600WP, S2600WPF and S2600WPQ.

3.3.3.4 I/O Module Support

To broaden the standard on-board feature set, the server board supports the option of adding a single I/O module providing external ports for a variety of networking interfaces. The I/O module attaches to a high density 80-pin connector on the Riser 2. Refer to *Intel® Server System H2000WP family Technical Product Specification* (Intel Order Number G52418) for more information.

3.4 Intel® C600-A PCH Functional Overview

The following sub-sections will provide an overview of the key features and functions of the Intel® C600-A chipset used on the server board. For more comprehensive chipset specific information, refer to the Intel® C600-A Series chipset documents through <http://www.intel.com/content/www/us/en/chipsets/server-chipsets/server-workstation-chipsets.html>.

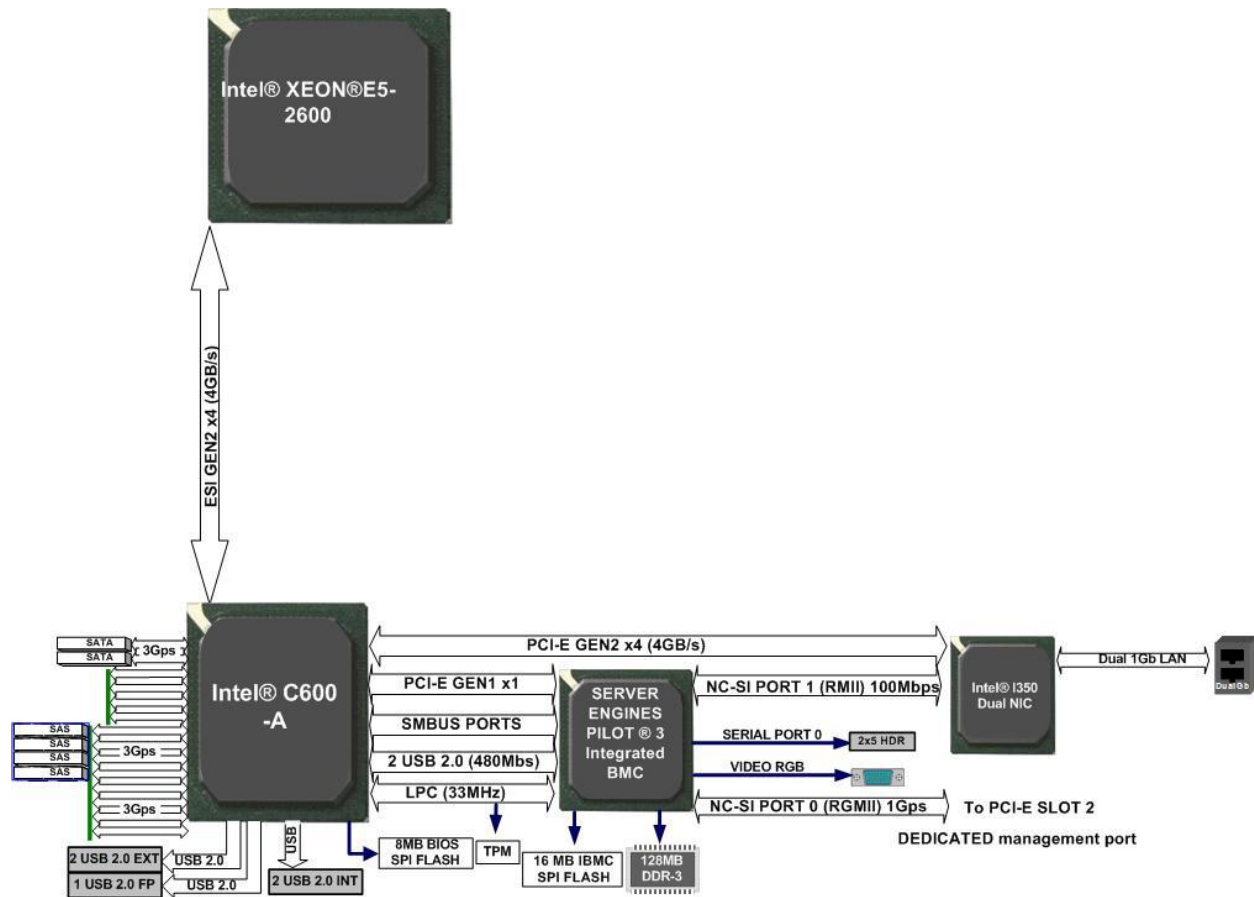

Figure 16. Intel® C600-A PCH connection

The Intel® C600-A PCH component provides extensive I/O support. Functions and capabilities include:

- *PCI Express* Base Specification, Revision 2.0* support for up to eight ports with transfers up to 5 GT/s
- *PCI Local Bus Specification, Revision 2.3* support for 33 MHz PCI operations (supports up to four Req/Gnt pairs)
- *ACPI Power Management Logic Support, Revision 4.0a*
- Enhanced DMA controller, interrupt controller, and timer functions
- Integrated Serial Attached SCSI host controllers at transfer rate up to 3Gb/s on up to eight ports
- Integrated Serial ATA host controllers with independent DMA operation on up to six ports
- USB host interface with two EHCI high-speed USB 2.0 Host controllers and 2 rate matching hubs provide support for support for up to fourteen USB 2.0 ports
- Integrated 10/100/1000 Gigabit Ethernet MAC with System Defense
- *System Management Bus (SMBus*) Specification, Version 2.0* with additional support for I2C* devices
- Supports Intel® Rapid Storage Technology (Intel® RST)

- Supports Intel® Virtualization Technology for Directed I/O (Intel® VT-d)
- Supports Intel® Trusted Execution Technology (Intel® TXT)
- Low Pin Count (LPC) interface
- Firmware Hub (FWH) interface support
- Serial Peripheral Interface (SPI) support
- Intel® Anti-Theft Technology (Intel® AT)
- JTAG Boundary Scan support

3.4.1 PCI Express*

The Intel® C600-A PCH provides up to eight PCI Express* Root Ports, supporting the *PCI Express* Base Specification, Revision 2.0*. Each Root Port x1 lane supports up to 5 Gb/s bandwidth in each direction (10 Gb/s concurrent). PCI Express* Root Ports 1-4 or Ports 5-8 can independently be configured to support four x1s, two x2s, one x2 and two x1s, or one x4 port widths.

From PCH on Intel® Server Board S2600WP, PCIe Port8 x1 Gen2 is connected to BMC Gen1 Uplink. Ports 1-4 are connected to Intel® I350 GbE NIC. The remaining PCIe Gen2 interconnect (Port 5-7, 1 based numbering) are unused.

3.4.2 Non-Transparent Bridge

PCI Express* Non-Transparent Bridge (NTB) acts as a gateway that enables high performance, low overhead communication between two intelligent subsystems, the local and the remote subsystems. The NTB allows a local processor to independently configure and control the local subsystem, provides isolation of the local host memory domain from the remote host memory domain while enabling status and data exchange between the two domains.

The PCI Express Port 3A of Intel® Xeon® Processor E5-2600 Product Families can be configured to be a transparent bridge or a NTB with x4/x8 linkwidth and Gen1/Gen2/Gen3 link speed. Also this NTB port could be attached to another NTB port or PCI Express* Root Port on another subsystem. NTB supports three 64bit BARs as configuration space or prefetchable memory windows that can access both 32bit and 64bit address space through 64bit BARs.

There are three NTB supported configuration:

- NTB Port to NTB Port Based Connection (Back-to-Back)
- NTB Port to Root Port Based Connection - Symmetric Configuration. The NTB port on the first system is connected to the root port of the second. The second system's NTB port is connected to the root port on the first system making this a fully symmetric configuration.
- NTB Port to Root Port Based Connection - Non-Symmetric Configuration. The root port on the first system is connected to the NTB port of the second system. And it is not necessary for the first system to be a of Intel® Xeon® Processor E5-2600 Product Families system.

3.4.3 Universal Serial Bus (USB)

There are fourteen USB 2.0 ports available from Intel® C600-A PCH. All ports are high-speed, full-speed and low-speed capable. A total of five USB 2.0 dedicated ports are used by Intel® Server Board S2600WP. The USB port distribution is as follows:

- ServerEngines* BMC PILOT III consumes two USB 2.0 ports (one USB1.1 and one USB2.0)
- Two rear USB 2.0 ports
- One internal USB port for extension of front-panel USB port
- Wake on USB is supported on the rear and front panel USB ports for S1 only. Standby power on USB ports is not required.

3.4.4 Serial Attached SCSI (SAS) and Serial ATA (SATA) Controller

The Intel® C600-A chipset provides storage support through two integrated controllers: AHCI and SCU. By default the server board will support up to six SATA ports: Two single6Gb/sec SATA ports routed from the AHCI controller to one white SATA connector labeled “SATA-1” on mother board and “SATA-0” on bridge board, and four 3Gb/sec SATA ports routed from the SCU to the multi-drive port connector labeled **SAS/SATA 0-3** (grouped as SCU0).

Note: The multi- drive port connector labeled **SAS/SATA 4-7** is NOT functional by default and is only enabled with the addition of an Intel® RAID C600 Storage Upgrade Key option supporting 8 SAS/SATA ports.

It supports the *Serial ATA Specification*, Revision 3.0, and several optional sections of the *Serial ATA II: Extensions to Serial ATA 1.0 Specification*, Revision 1.0 (AHCI support is required for some elements).

Intel® Server Board S2600WP implements six SATA or SAS ports. The implementation is as follows:

Table 9. Intel® Server Board S2600WP SATA/SAS port

Port#	Speed	Connector
0	6Gb/s SATA	On Bridge Board
1	6Gb/s SATA	On Server board
SCU0	3Gb/s SATA (AHCI only); 3Gb/s SATA/SAS (non-AHCI needs storage upgrade key to support SAS)	Bridge Board Slot
0		
1		
2		
3		

There are two embedded software RAID options using the storage ports configured from the SCU only:

- Intel® Embedded Server RAID Technology 2 (ESRT2) based on LSI* MegaRAID SW RAID technology supporting SATA RAID levels 0, 1, 5, and 10
- Intel® Rapid Storage Technology (RSTe) supporting SATA RAID levels 0, 1, 5, and 10

The server board is capable of supporting additional chipset embedded SAS and RAID options from the SCU controller when configured with one of several available Intel® RAID C600-A

Storage Upgrade Keys. Upgrade keys install onto a four-pin connector on the server board labeled **STOR UPG Key**. The following table identifies available upgrade key options and their supported features.

Table 10. Intel® RAID C600-A Storage Upgrade Key Options for S2600WP

Intel® RAID C600-A Upgrade Key Options (Intel® Product Codes)	Key Color	Intel® RAID C600-A Upgrade Key Description	S2600WP SCU RAID availability Description
Default – No option key installed	N/A	4 Port SATA with Intel® ESRT RAID 0,1,10 and Intel® RSTe RAID 0,1,5,10	4 Port SATA with Intel® ESRT RAID 0,1,10 and Intel® RSTe RAID 0,1,5,10
RKSATA4R5	Black	4 Port SATA with Intel® ESRT2 RAID 0,1, 5, 10 and Intel® RSTe RAID 0,1,5,10	4 Port SATA with Intel® ESRT2 RAID 0,1, 5, 10 and Intel® RSTe RAID 0,1,5,10
RKSATA8	Blue	8 Port SATA with Intel® ESRT2 RAID 0,1, 10 and Intel® RSTe RAID 0,1,5,10	4 Port SATA with Intel® ESRT2 RAID 0,1, 10 and Intel® RSTe RAID 0,1,5,10
RKSATA8R5	White	8 Port SATA with Intel® ESRT2 RAID 0,1, 5, 10 and Intel® RSTe RAID 0,1,5,10	4 Port SATA with Intel® ESRT2 RAID 0,1, 5, 10 and Intel® RSTe RAID 0,1,5,10
RKSAS4	Green	4 Port SAS with Intel® ESRT2 RAID 0,1, 10 and Intel® RSTe RAID 0,1,10	4 Port SAS with Intel® ESRT2 RAID 0,1, 10 and Intel® RSTe RAID 0,1,10
RKSAS4R5	Yellow	4 Port SAS with Intel® ESRT2 RAID 0,1, 5, 10 and Intel® RSTe RAID 0,1,10	4 Port SAS with Intel® ESRT2 RAID 0,1, 5, 10 and Intel® RSTe RAID 0,1,10
RKSAS8	Orange	8 Port SAS with Intel® ESRT2 RAID 0,1, 10 and Intel® RSTe RAID 0,1,10	4 Port SAS with Intel® ESRT2 RAID 0,1, 10 and Intel® RSTe RAID 0,1,10
RKSAS8R5	Purple	8 Port SAS with Intel® ESRT2 RAID 0,1, 5, 10 and Intel® RSTe RAID 0,1,10	4 Port SAS with Intel® ESRT2 RAID 0,1, 5, 10 and Intel® RSTe RAID 0,1,10

Note: The eight-port Storage Upgrade Key can also implement the RAID function for S2600WP, but only four ports (SCU0) can be configured as proper RAID level. SCU at ESRT2 mode supports Maximum drive = 8 (with or without SAS expander option installed)

Additional information for the on-board RAID features and functionality can be found in the *Intel® RAID Software Users Guide* (Intel Document Number D29305).

3.4.5 PCI Interface

The Intel® C600 PCH PCI Interface provides a 33MHz, Revision 2.3 implementation. It integrates a PCI arbiter that supports up to four external PCI bus masters in addition to the PCH internal requests. This allows for combinations of up to four PCI down devices and PCI slots.

3.4.6 Low Pin Count (LPC) Interface

The Intel® C600-A PCH implements an LPC Interface as described in the LPC 1.1 Specification. The Low Pin Count (LPC) bridge function of the PCH resides in PCI Device 31:Function 0. In addition to the LPC bridge interface function, D31:F0 contains other functional units including DMA, interrupt controllers, timers, power management, system management, GPIO, and RTC.

3.4.7 Digital Media Interface (DMI)

Digital Media Interface (DMI) is the chip-to-chip connection between the processor and Intel® C600-A PCH. This high-speed interface integrates advanced priority-based servicing allowing for concurrent traffic and true isochronous transfer capabilities. Base functionality is completely software-transparent, permitting current and legacy software to operate normally.

3.4.8 Serials Peripheral Interface (SPI)

The Intel® C600-A PCH implements an SPI Interface as an alternative interface for the BIOS flash device. An SPI flash device can be used as a replacement for the FWH, and is required to support Gigabit Ethernet and Intel® Active Management Technology. The PCH supports up to two SPI flash devices with speeds up to 50 MHz, utilizing two chip select pins.

3.4.9 Compatibility Modules (DMA Controller, Timer/Counters, Interrupt Controller)

The DMA controller incorporates the logic of two 82C37 DMA controllers, with seven independently programmable channels. Channels 0–3 are hardwired to 8-bit, count-by-byte transfers, and channels 5–7 are hardwired to 16-bit, count-by-word transfers. Any two of the seven DMA channels can be programmed to support fast Type-F transfers. Channel 4 is reserved as a generic bus master request.

The Intel® C600-A PCH supports LPC DMA, which is similar to ISA DMA, through the PCH's DMA controller. LPC DMA is handled through the use of the LDRQ# lines from peripherals and special encoding on LAD[3:0] from the host. Single, Demand, Verify, and Increment modes are supported on the LPC interface.

The timer/counter block contains three counters that are equivalent in function to those found in one 82C54 programmable interval timer. These three counters are combined to provide the system timer function, and speaker tone. The 14.31818 MHz oscillator input provides the clock source for these three counters.

The Intel® C600-A PCH provides an ISA-Compatible Programmable Interrupt Controller (PIC) that incorporates the functionality of two, 82C59 interrupt controllers. The two interrupt controllers are cascaded so that 14 external and two internal interrupts are possible. In addition, the PCH supports a serial interrupt scheme. All of the registers in these modules can be read and restored. This is required to save and restore system state after power has been removed and restored to the platform.

3.4.10 Advanced Programmable Interrupt Controller (APIC)

In addition to the standard ISA compatible Programmable Interrupt Controller (PIC) described in the previous section, the Intel® C600-A PCH incorporates the Advanced Programmable Interrupt Controller (APIC).

3.4.11 Real Time Clock (RTC)

The Intel® C600-A PCH contains a Motorola MC146818B-compatible real-time clock with 256 bytes of battery-backed RAM. The real-time clock performs two key functions: keeping track of the time of day and storing system data, even when the system is powered down. The RTC operates on a 32.768KHz crystal and a 3V battery. The RTC also supports two lockable memory ranges. By setting bits in the configuration space, two 8-byte ranges can be locked to read and write accesses. This prevents unauthorized reading of passwords or other system

security information. The RTC also supports a date alarm that allows for scheduling a wake up event up to 30 days in advance, rather than just 24 hours in advance.

3.4.12 GPIO

Various general purpose inputs and outputs are provided for custom system design. The number of inputs and outputs varies depending on the Intel® C600-A PCH configuration.

3.4.13 Enhanced Power Management

The Intel® C600-A PCH power management functions include enhanced clock control and various low-power (suspend) states. A hardware-based thermal management circuit permits software-independent entrance to low-power states. The PCH contains full support for the Advanced Configuration and Power Interface (ACPI) Specification, Revision 4.0a.

3.4.14 Fan Speed Control

The Intel® C600-A PCH integrates four fan speed sensors (four TACH signals) and four fan speed controllers (three Pulse Width Modulator signals), which enables monitoring and controlling up to four fans on the system. With the new implementation of the single-wire Simple Serial Transport (SST) 1.0 bus and Platform Environmental Control Interface (PECI), the PCH provides an easy way to connect to SST-based thermal sensors and access the processor thermal data.

3.4.15 Intel® Virtualization Technology for Direct I/O (Intel® VT-d)

The Intel® Virtualization Technology is designed to support multiple software environments sharing same hardware resources. Each software environment may consist of an OS and applications. The Intel® Virtualization Technology can be enabled or disabled in the BIOS setup. The default behavior is disabled.

Note: If the setup options are changed to enable or disable the Virtualization Technology setting in the processor, the user must perform an AC power cycle for the changes to take effect.

The chipset supports DMA remapping from inbound PCI Express* memory Guest Physical Address (GPA) to Host Physical Address (HPA). PCI devices are directly assigned to a virtual machine leading to a robust and efficient virtualization.

3.4.16 KVM/Serial Over LAN (SOL) Function

These functions support redirection of keyboard, mouse, and text screen to a terminal window on a remote console. The keyboard, mouse, and text redirection enables the control of the client machine through the network without the need to be physically near that machine. Text, mouse, and keyboard redirection allows the remote machine to control and configure the client by entering BIOS setup. The KVM/SOL function emulates a standard PCI serial port and redirects the data from the serial port to the management console using LAN. KVM has additional requirements of internal graphics and SOL may be used when KVM is not supported.

3.4.17 IDE-R Function

The IDE-R function is an IDE Redirection interface that provides client connection to management console ATA/ATAPI devices. When booting from IDE-R, the IDE-R interface will send the client's ATA/ATAPI command to the management console. The management console will then provide a response command back to the client. A remote machine can setup a diagnostic SW or OS installation image and direct the client to boot from IDE-R. The IDE-R

interface is the same as the IDE interface and is compliant with ATA/ATAPI-6 specifications. IDE-R does not conflict with the usage of PXE boot. The system can support both interfaces and continue to boot from the PXE as with any other boot devices. However, during management boot session the Intel® AMT solution will use IDE-R when remote boot is required. The devices attached to the IDER channel are only visible to software during management boot session. During normal boot session the IDE-R channel does not appear as a present device.

3.4.18 Manageability

Intel® C600-A PCH integrates several functions designed to manage the system and lower the total cost of ownership (TCO) of the system. These system management functions are designed to report errors, diagnose the system, and recover from system lockups without the aid of an external microcontroller. The functionality provided by the SPS firmware is different from Intel® Active Management Technology (Intel® AMT or AT) provided by the ME on client platforms.

- **TCO Timer:** The Intel® C600-A PCH's integrated programmable TCO timer is used to detect system locks. The first expiration of the timer generates an SMI# that the system can use to recover from a software lock. The second expiration of the timer causes a system reset to recover from a hardware lock.
- **Processor Present Indicator:** The Intel® C600-A PCH looks for the processor to fetch the first instruction after reset. If the processor does not fetch the first instruction, the PCH will reboot the system.
- **ECC Error Reporting:** When detecting an ECC error, the host controller has the ability to send one of several messages to the Intel® C600-A PCH. The host controller can instruct the PCH to generate any of SMI#, NMI, SERR#, or TCO interrupt.
- **Function Disable:** The Intel® C600-A PCH provides the ability to disable the following integrated functions: LAN, USB, LPC, Intel® HD Audio, SATA, PCI Express* or SMBus*. Once disabled, these functions no longer decode I/O, memory, or PCI configuration space. Also, no interrupts or power management events are generated from the disabled functions.
- **Intruder Detect:** The Intel® C600-A PCH provides an input signal (INTRUDER#) that can be attached to a switch that is activated by the system case being opened. The Intel® C600-A PCH can be programmed to generate either SMI# or TCO interrupt due to an active INTRUDER# signal.

3.4.19 System Management Bus (SMBus 2.0*)

The Intel® C600-A PCH contains a SMBus* Host interface that allows the processor to communicate with SMBus* slaves. This interface is compatible with most I²C devices. Special I²C commands are implemented.

The Intel® C600-A PCH's SMBus* host controller provides a mechanism for the processor to initiate communications with SMBus* peripherals (slaves). Also, the PCH supports slave functionality, including the Host Notify protocol. Hence, the host controller supports eight command protocols of the SMBus* interface (see *System Management Bus (SMBus*) Specification, Version 2.0*): Quick Command, Send Byte, Receive Byte, Write Byte/Word, Read Byte/Word, Process Call, Block Read/Write, and Host Notify.

The Intel® C600-A PCH's SMBus* also implements hardware-based Packet Error Checking for data robustness and the Address Resolution Protocol (ARP) to dynamically provide address to all SMBus* devices.

3.4.20 Network Interface Controller (NIC)

Network interface support is provided from the onboard Intel® I350 NIC, which is a dual-port, compact component with two fully integrated GbE Media Access Control (MAC) and Physical Layer (PHY) ports. The Intel® I350 NIC provides the server board with support for dual LAN ports designed for 10/100/1000 Mbps operation. Refer to the Intel® I350 Gigabit Ethernet Controller Datasheet for full details of the NIC feature set.

The NIC device provides a standard IEEE 802.3 Ethernet interface for 1000BASE-T, 100BASE-TX, and 10BASE-T applications (802.3, 802.3u, and 802.3ab) and is capable of transmitting and receiving data at rates of 1000 Mbps, 100 Mbps, or 10 Mbps.

The Intel® I350 controller also requires the use of Intel® C600-A PCH SMBus* interface during Sleep states S4 and S5 as well as for ME Firmware. The Intel® I350 LAN controller will be on standby power so that Wake on LAN and manageability functions can be supported.

Intel® I350 will be used in conjunction with the Server Engines PILOT III BMC for out of band Management traffic. The BMC will communicate with Intel® I350 over a NC-SI interface (RMII physical). The NIC will be on standby power so that the BMC can send management traffic over the NC-SI interface to the network during sleep states S4 and S5.

The NIC supports the normal RJ-45 LINK/Activity speed LEDs as well as the Proset ID function. These LEDs are powered from a Standby voltage rail.

The link/activity LED (at the right of the connector) indicates network connection when on, and transmit/receive activity when blinking. The speed LED (at the left of the connector) indicates 1000-Mbps operation when green, 100-Mbps operation when amber, and 10-Mbps when off. The following table provides an overview of the LEDs:

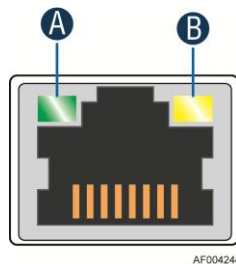

LED Color	LED State	NIC State
Green/Amber (B)	Off	10 Mbps
	Amber	100 Mbps
	Green	1000 Mbps
Green (A)	On	Active Connection
	Blinking	Transmit/Receive activity

Figure 17. 1GbE NIC port LED

3.4.20.1 MAC Address Definition

The Intel® Server Board S2600WP has the following four MAC addresses assigned to it at the Intel® factory.

- NIC 1 MAC address (for OS usage)

- NIC 2 MAC address = NIC 1 MAC address + 1 (for OS usage)
- BMC LAN channel 1 MAC address = NIC1 MAC address + 2
- BMC LAN channel 2 MAC address = NIC1 MAC address + 3
- BMC LAN channel 3 (Dedicated Server Management NIC) MAC address = NIC1 MAC address + 4

The Intel® Server Board S2600WP has a white MAC address sticker included with the board. The sticker displays the NIC 1 MAC address in both bar code and alphanumeric formats.

3.4.20.2 LAN Manageability

Port 2 of the Intel® I350 NIC will be used by the BMC firmware to send management traffic. In standby in order to save power, Port2 will be the only port to support Wake on LAN. The EEPROM is programmed to turn off this feature from the other ports in order to maximize power savings during sleep states.

3.4.20.3 Wake-On-LAN

WOL is supported on the Intel® I350 LAN controller for all supported Sleep states.

3.4.20.4 LAN Connector Ordering

The Intel® I350 NIC is connected to independent RJ-45 ports for NIC 1 and NIC 2.

3.4.20.5 Intel® I350 Thermal Sensor

Intel® I350 NIC will have an integrated digital thermal sensor accessible through CSR and manageability registers. The thermal sensor can be programmed to trigger digital pins and thermal throttling with hysteresis.

3.5 InfiniBand* Controller

Intel® Server Board S2600WPQ/S2600WPF are populated with a new generation InfiniBand*/Ethernet adapter device. Mellanox* ConnectX*-3 supports Virtual Protocol Interconnect® (VPI), providing InfiniBand* interfaces. The functional diagram is as below:

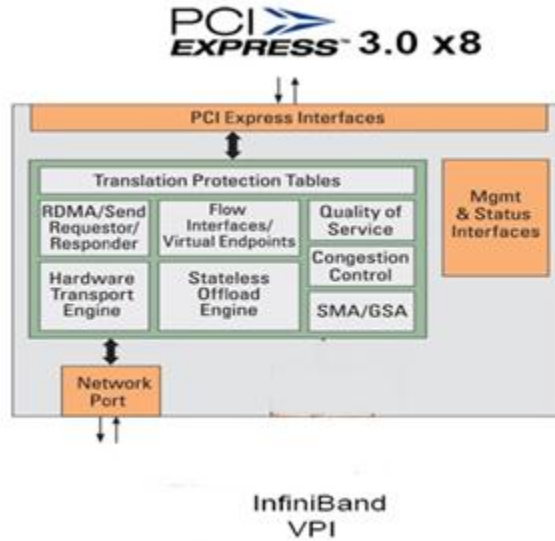

Figure 18. ConnectX-3* function block diagram

Major features and functions include:

- Single InfiniBand* Port: SDR/DDR/QDR on S2600WPQ, SDR/DDR/QDR/FDR on S2600WPF with port remapping in firmware
- Performance optimization: achieving single port line-rate bandwidth
- PCI Express* 3.0 x8 to achieve 2.5, 5 or 8GT/s link rate
- Optimized for LOM: Small footprint, minimal peripherals, WOL, integrated sensors and BMC interface
- Low power consumption: 6.5Watt typical

3.5.1 Device Interfaces

Below is a list of major interfaces of Mellanox* ConnectX-3* chip:

- **Clock and Reset signals:** include core clock input and chip reset signals
- **Uplink Bus:** The PCI Express* bus is a high-speed uplink interface used to connect Mellanox* ConnectX-3* to the host processor. The Mellanox* ConnectX-3* supports a PCI Express* 3.0 x8 uplink connection with transfer rates of 2.5GT/s, 5GT/s and 8GT/s per lane. Throughout this document, the PCI Express* interface may also be referred to as the “uplink” interface
- **Network Interface:** Single network port connecting the device to a network fabric in one of the configurations described in below table.

Table 11. Network port configuration

Port Configured as
10/20/40/56 Gb/s InfiniBand*

- **Flash interface:** Chip initialization and host boot

- **I2C Compatible Interfaces:** For chip, QSFP connector, and chassis configure and monitor
- **Management Link:** Connect to BMC through SMBus* and NC-SI
- **Others including:** MDIO, GPIO and JTAG

3.5.2 Quad Small Form-factor Pluggable (QSFP) connector

Port of the Mellanox® ConnectX-3* is connected to a single QSFP connector on Intel® Server Board S2600WPQ and S2600WPF. Below is the application reference between Mellanox® ConnectX-3* and QSFP:

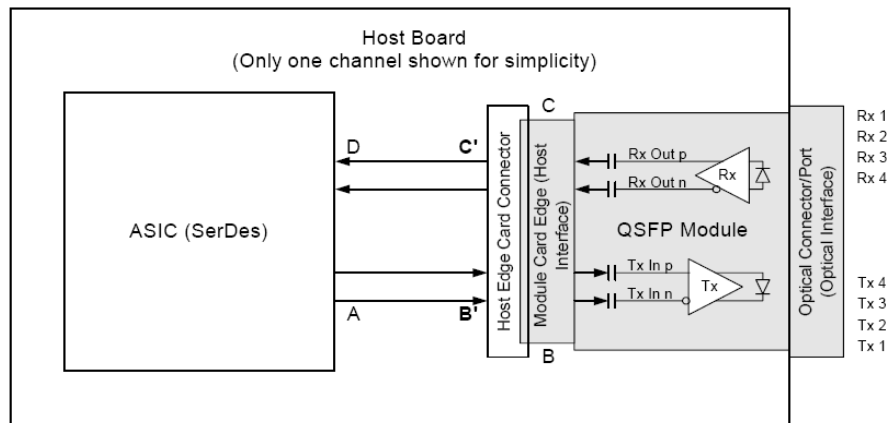

Figure 19. Connection between Mellanox® ConnectX-3* and QSFP

The QSFP module and all pins shall withstand 500V electrostatic discharge based on Human Body Model per JEDEC JESD22-A114-B.

The module shall meet ESD requirements given in EN61000-4-2, criterion B test specification such that when installed in a properly grounded cage and chassis the units are subjected to 15KV air discharges during operation and 8KV direct contact discharges to the case.

3.6 Integrated Baseboard Management Controller Overview

The server board utilizes the Baseboard Management features of the Server Engines® Pilot-III Server Management Controller. The following is an overview of the features as implemented on the server board from each embedded controller.

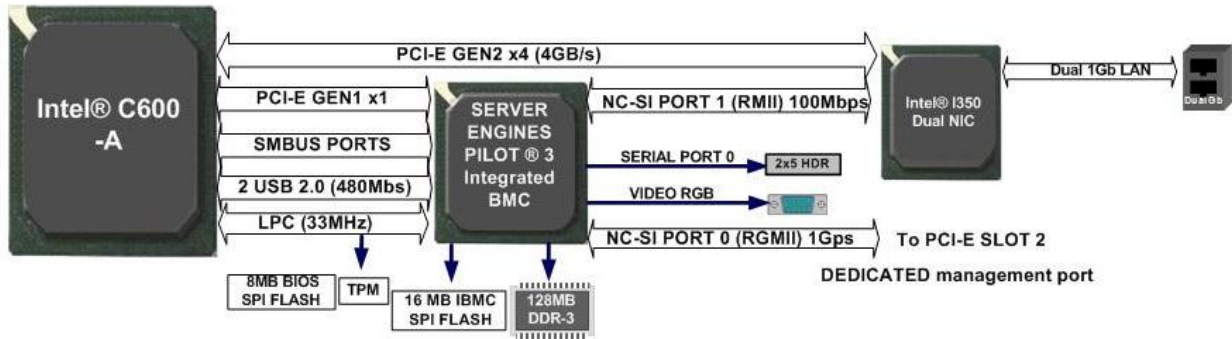

Figure 20. Integrated BMC implementation overview

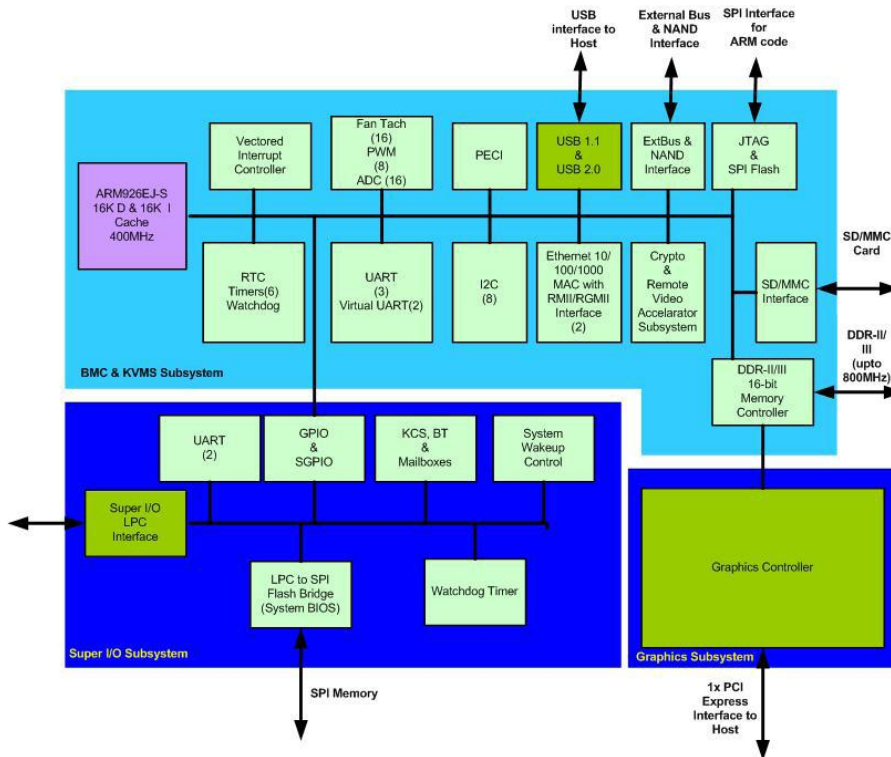

Figure 21. Integrated BMC Functional Block Diagram

The Integrated BMC is provided by an embedded ARM9 controller and associated peripheral functionality that is required for IPMI-based server management. Firmware usage of these hardware features is platform dependent.

The following is a summary of the Integrated BMC management hardware features that comprise the BMC:

- 400MHz 32-bit ARM9 processor with memory management unit (MMU)
- Two independent 10/100/1000 Ethernet Controllers with RMII/RGMII support
- DDR2/3 16-bit interface with up to 800 MHz operation
- 12 10-bit ADCs
- Sixteen fan tachometers

- Eight Pulse Width Modulators (PWM)
- Chassis intrusion logic
- JTAG Master
- Eight I2C interfaces with master-slave and SMBus* timeout support. All interfaces are SMBus* 2.0 compliant.
- Parallel general-purpose I/O Ports (16 direct, 32 shared)
- Serial general-purpose I/O Ports (80 in and 80 out)
- Three UARTs
- Platform Environmental Control Interface (PECI)
- Six general-purpose timers
- Interrupt controller
- Multiple SPI flash interfaces
- NAND/Memory interface
- Sixteen mailbox registers for communication between the BMC and host
- LPC ROM interface
- BMC watchdog timer capability
- SD/MMC card controller with DMA support
- LED support with programmable blink rate controls on GPIOs
- Port 80h snooping capability
- Secondary Service Processor (SSP), which provides the HW capability of offloading time critical processing tasks from the main ARM core.

ServerEngines* Pilot III contains an integrated SIO, KVMS subsystem and graphics controller with the following features:

3.6.1 Super I/O Controller

The integrated super I/O controller provides support for the following features as implemented on the server board:

- Keyboard Style/BT interface for BMC support
- Two Fully Functional Serial Ports, compatible with the 16C550
- Serial IRQ Support
- Up to 16 Shared GPIO available for host processor
- Programmable Wake-up Event Support
- Plug and Play Register Set
- Power Supply Control

3.6.1.1 Keyboard and Mouse Support

The server board does not support PS/2 interface keyboards and mice. However, the system BIOS recognizes USB specification-compliant keyboard and mice.

3.6.1.2 Wake-up Control

The super I/O contains functionality that allows various events to power on and power off the system.

3.6.2 Graphics Controller and Video Support

The integrated graphics controller provides support for the following features as implemented on the server board:

- Integrated Graphics Core with 2D Hardware accelerator
- DDR3 memory interface supports up to 256Mbytes of memory
- Supports all display resolutions up to 1600 x 1200 16bpp @ 60Hz
- High speed Integrated 24-bit RAMDAC

The integrated video controller supports all standard IBM* VGA modes. The following table shows the 2D modes supported for both CRT and LCD:

Table 12. Video Modes

2D Mode	Refresh Rate (Hz)	2D Video Mode Support		
		8 bpp	16 bpp	32 bpp
640x480	60, 72, 75, 85, 90, 100, 120, 160, 200	Supported	Supported	Supported
800x600	60, 70, 72, 75, 85, 90, 100, 120, 160	Supported	Supported	Supported
1024x768	60, 70, 72, 75, 85, 90, 100	Supported	Supported	Supported
1152x864	43, 47, 60, 70, 75, 80, 85	Supported	Supported	Supported
1280x1024	60, 70, 74, 75	Supported	Supported	Supported
1600x1200**	60	Supported	Supported	Supported

** Video resolutions at 1600x1200 are only supported through the external video connector located on the rear I/O section of the server board. Utilizing the optional front panel video connector may result in lower video resolutions.

The server board provides two video interfaces. The primary video interface is accessed using a standard 15-pin VGA connector found on the back edge of the server board. In addition, video signals are routed to a 14-pin header labeled "FP_Video" on the leading edge of the server board, allowing for the option of cabling to a front panel video connector. Attaching a monitor to the front panel video connector will disable the primary external video connector on the back edge of the board.

The BIOS supports dual-video mode when an add-in video card is installed.

In the single mode (dual monitor video = disabled), the on-board video controller is disabled when an add-in video card is detected.

In the dual mode (on-board video = enabled, dual monitor video = enabled), the on-board video controller is enabled and is the primary video device. The add-in video card is allocated resources and is considered the secondary video device. The BIOS Setup utility provides options to configure the feature as follows:

Table 13. Video mode

On-board Video	Enabled Disabled	
Dual Monitor Video	Enabled Disabled	Shaded if on-board video is set to "Disabled"

3.6.3 Remote KVM

The Integrated BMC contains a remote KVM subsystem with the following features:

- USB 2.0 interface for Keyboard, Mouse and Remote storage such as CD/DVD ROM and floppy
- USB 1.1/USB 2.0 interface for PS2 to USB bridging, remote Keyboard and Mouse
- Hardware Based Video Compression and Redirection Logic
- Supports both text and Graphics redirection
- Hardware assisted Video redirection using the Frame Processing Engine
- Direct interface to the Integrated Graphics Controller registers and Frame buffer
- Hardware-based encryption engine

4. Platform Management Functional Overview

Platform management functionality is supported by several hardware and software components integrated on the server board that work together to control system functions, monitor and report system health, and control various thermal and performance features in order to maintain (when possible) server functionality in the event of component failure and/or environmentally stressed conditions.

This chapter provides a high level overview of the platform management features and functionality implemented on the server board. For more in depth and design level Platform Management information, please reference the *BMC Core Firmware External Product Specification (EPS)* (Intel Order Number: G31813) and *BIOS Core External Product Specification (EPS)* for Intel® Server products based on the Intel® Xeon® processor E5-4600,2600, and 1600 product families.

4.1 Baseboard Management Controller (BMC) Firmware Feature Support

The following sections outline general features that the integrated BMC firmware can support. Support and utilization for some features is dependent on the server platform in which the server board is integrated and any additional system level components and options that may be installed.

4.1.1 IPMI 2.0 Features

- Baseboard management controller (BMC)
- IPMI Watchdog timer
- Messaging support, including command bridging and user/session support
- Chassis device functionality, including power/reset control and BIOS boot flags support
- Event receiver device: The BMC receives and processes events from other platform subsystems.
- Field Replaceable Unit (FRU) inventory device functionality: The BMC supports access to system FRU devices using IPMI FRU commands.
- System Event Log (SEL) device functionality: The BMC supports and provides access to a SEL.
- Sensor Data Record (SDR) repository device functionality: The BMC supports storage and access of system SDRs.
- Sensor device and sensor scanning/monitoring: The BMC provides IPMI management of sensors. It polls sensors to monitor and report system health.
- IPMI interfaces
- Host interfaces include system management software (SMS) with receive message queue support, and server management mode (SMM)
- IPMB interface
- LAN interface that supports the IPMI-over-LAN protocol (RMCP, RMCP+)
 - Serial-over-LAN (SOL)
 - ACPI state synchronization: The BMC tracks ACPI state changes that are provided by the BIOS.

- BMC self-test: The BMC performs initialization and run-time self-tests and makes results available to external entities.
- See also the *Intelligent Platform Management Interface Specification Second Generation v2.0*.

4.1.2 Non IPMI Features

The BMC supports the following non-IPMI features.

- In-circuit BMC firmware update
- BMC FW reliability enhancements:
 - Redundant BMC boot blocks to avoid possibility of a corrupted boot block resulting in a scenario that prevents a user from updating the BMC.
 - BMC System Management Health Monitoring
- Fault resilient booting (FRB): FRB2 is supported by the watchdog timer functionality.
- Enable/Disable of System Reset Due CPU Errors
- Chassis intrusion detection
- Fan speed control
- Fan redundancy monitoring and support
- Hot-swap fan support
- Power Supply Fan Sensors
- System Airflow Monitoring
- Exit Air Temperature Monitoring
- Acoustic management: Support for multiple fan profiles
- Ethernet Controller Thermal Monitoring
- Global Aggregate Temperature Margin Sensor
- Platform environment control interface (PECI) thermal management support
- Memory Thermal Management
- DIMM temperature monitoring: New sensors and improved acoustic management using closed-loop fan control algorithm taking into account DIMM temperature readings.
- Power supply redundancy monitoring and support
- Power unit management: Support for power unit sensor. The BMC handles power-good dropout conditions.
- Intel® Intelligent Power Node Manager support
- Signal testing support: The BMC provides test commands for setting and getting platform signal states.
- The BMC generates diagnostic beep codes for fault conditions.
- System GUID storage and retrieval
- Front panel management: The BMC controls the system status LED and chassis ID LED. It supports secure lockout of certain front panel functionality and monitors button presses. The chassis ID LED is turned on using a front panel button or a command.
- Local Control Display Panel support
- Power state retention

- Power fault analysis
- Intel® Light-Guided Diagnostics
- Address Resolution Protocol (ARP): The BMC sends and responds to ARPs (supported on embedded NICs).
- Dynamic Host Configuration Protocol (DHCP): The BMC performs DHCP (supported on embedded NICs).
- E-mail alerting
- Embedded web server
 - Support for embedded web server UI in Basic Manageability feature set.
 - Human-readable SEL
 - Additional system configurability
 - Additional system monitoring capability
 - Enhanced on-line help
- Integrated KVM
- Integrated Remote Media Redirection
- Local Directory Access Protocol (LDAP) support
- Sensor and SEL logging additions/enhancements (for example additional thermal monitoring capability)
- SEL Severity Tracking and the Extended SEL
- BMC Data Repository (Managed Data Region Feature)
- Embedded platform debug feature which allows capture of detailed data for later analysis.
- Provisioning and inventory enhancements:
 - Signed Firmware (improved security)
 - Inventory data/system information export (partial SMBIOS table)
- DCMI 1.1 compliance (product-specific).
- Support for EU Lot6 compliance
- Management support for PMBus* rev1.2 compliant power supplies
- Energy Star Server Support
- SmarT/CLST
- Power Supply Cold Redundancy
- Power Supply FW Update
- Power Supply Compatibility Check

4.1.3 New Manageability Features

The new generation EPSD server products offer a number of changes and additions to the manageability features that are supported on the previous generation of servers. The following is a list of the more significant changes that are common to all EPSD servers of this new generation:

- Sensor and SEL logging additions/enhancements (for example additional thermal monitoring capability)
- SEL Severity Tracking and the Extended SEL

- Embedded platform debug feature which allows capture of detailed data for later analysis.
- Provisioning and inventory enhancements:
 - Signed Firmware (improved security)
 - Inventory data/system information export (partial SMBIOS table)
- Enhancements to fan speed control.
- DCMI 1.1 compliance (product-specific).
- Support for embedded web server UI in Basic Manageability feature set.
- Enhancements to embedded web server
 - Human-readable SEL
 - Additional system configurability
 - Additional system monitoring capability
 - Enhanced on-line help
- Enhancements to KVM redirection
 - Support for higher resolution
- Support for EU Lot6 compliance
- Management support for PMBus* rev1.2 compliant power supplies
- BMC Data Repository (Managed Data Region Feature)
- Local Control Display Panel
- System Airflow Monitoring
- Exit Air Temperature Monitoring
- Ethernet Controller Thermal Monitoring
- Global Aggregate Temperature Margin Sensor
- Memory Thermal Management
- Power Supply Fan Sensors
- Enable/Disable of System Reset Due CPU Errors
- Energy Star Server Support
- SmaRT/CLST
- Power Supply Cold Redundancy
- Power Supply FW Update
- Power Supply Compatibility Check
- BMC FW reliability enhancements:
 - Redundant BMC boot blocks to avoid possibility of a corrupted boot block resulting in a scenario that prevents a user from updating the BMC.
 - BMC System Management Health Monitoring

4.3 Advanced Configuration and Power Interface (ACPI)

The server board has support for the following ACPI states:

Table 14. ACPI Power States

State	Supported	Description
S0	Yes	<p>Working.</p> <ul style="list-style-type: none"> ▪ The front panel power LED is on (not controlled by the BMC). ▪ The fans spin at the normal speed, as determined by sensor inputs. ▪ Front panel buttons work normally.
S1	Yes	<p>Sleeping. Hardware context is maintained; equates to processor and chipset clocks being stopped.</p> <ul style="list-style-type: none"> ▪ The front panel power LED blinks at a rate of 1 Hz with a 50% duty cycle (not controlled by the BMC). ▪ The watchdog timer is stopped. ▪ The power, reset, front panel NMI, and ID buttons are unprotected. ▪ Fan speed control is determined by available SDRs. Fans may be set to a fixed state, or basic fan management can be applied. <p>The BMC detects that the system has exited the ACPI S1 sleep state when the BIOS SMI handler notifies it.</p>
S2	No	Not supported.
S3	No	Supported only on Workstation platforms. See appropriate Platform Specific Information for more information.
S4	No	Not supported.
S5	Yes	<p>Soft off</p> <ul style="list-style-type: none"> ▪ The front panel buttons are not locked. ▪ The fans are stopped. ▪ The power-up process goes through the normal boot process. ▪ The power, reset, front panel NMI, and ID buttons are unlocked.

4.4 Platform Management SMBus* and I²C Implementation

SMBus*/I²C interconnections are a fundamental interface for various manageability components. There are three busses that are used in a multi-master fashion.

- **Primary IPMB.** An IPMB header is provided on the baseboard to support connectivity with 3rd party management PCIe cards. This bus operates as 100 kHz bus.
- **Secondary IPMB.** This is the SMLink0 bus that connects the BMC with the ME in the SSB. This bus is considered a secondary IPMB. The ME and BMC communicate over this bus using IPMB protocol messages. This bus runs at close to 400 kHz (due to a Patsburg/Cougarpoint SSB constraint, it cannot achieve a full 400 kHz operation). Any devices on the bus must be compatible with a 400 kHz bus speed.
- **PMBus*.** This is the SMLink1 bus that both the ME and BMC use to communicate with the power supplies. This bus operates as 100 kHz bus.

For all multi-master busses, the master that initiates a transaction is responsible for any bus recovery sequence if the bus hangs.

The BMC acts as master for the other busses connected to it.

4.5 BMC Internal Timestamp Clock

The BMC maintains an internal timestamp clock that is used by various BMC subsystems, example for time stamping SEL entries. As part of BMC initialization after AC power is applied or the BMC is reset, the BMC initializes this internal clock to the value retrieved from the SSB component's RTC through an SMBus* slave read operation. This is the system RTC and is on the battery power well so it maintains the current time even when there is no AC supplied to the system.

The BMC reads the RTC using the same SMBus* (the "host SMBus*") that is used by BIOS during POST, so the BMC FW must not attempt to access the RTC between the time the system is reset or powered-on and POST completes, as indicated by the assertion of the POST-complete signal. Additionally, the BMC should cancel any pending reads of the RTC if the POST-complete signal de-asserts (for example, due to a reset). Normally the BMC reads the RTC when AC power is first applied and before the system is powered-on, so this is not a concern. However, if AC power is applied and the power button is immediately pressed, it is possible that POST would be in progress by the time the BMC is ready to read the RTC. Another potential conflict can occur if the BMC gets reset and POST is in progress when the BMC has re-initialized. For either of these cases, the BMC FW initializes its internal time clock to 0 and begins counting up from there. When POST completes, BIOS will then update the BMC's time clock to the current system time.

The BMC's internal timestamp clock is read and set using the *Get SEL Time* and *Set SEL Time* commands, respectively. The *Get SDR Time* command can also be used to read the timestamp clock. These commands and the IPMI time format are specified in the IPMI 2.0 specification. Whenever the BMC receives the *Set SEL Time* command, it updates only its internal time clock. Note that an update of this internal time clock does not result in a change to the system RTC.

4.6 Sensor Monitoring

The BMC monitors system hardware and reports system health. The information gathered from physical sensors is translated into IPMI sensors as part of the "IPMI Sensor Model". The BMC also reports various system state changes by maintaining virtual sensors that are not specifically tied to physical hardware.

4.7 Messaging Interfaces

The supported BMC communication interfaces include:

- Host SMS interface by means of low pin count (LPC)/keyboard controller style (KCS) interface
- Host SMM interface by means of low pin count (LPC)/keyboard controller style (KCS) interface
- Intelligent Platform Management Bus (IPMB) I2C interface
- LAN interface using the IPMI-over-LAN protocols

4.7.1 Channel Management

Every messaging interface is assigned an IPMI channel ID by IPMI 2.0. Commands are provided to configure each channel for privilege levels and access modes. Table 15 shows the standard channel assignments:

Table 15. Standard Channel Assignments

Channel ID	Interface	Supports Sessions
0	Primary IPMB	No
1	LAN 1	Yes
2	LAN 2	Yes
3	LAN3 1 (Provided by the Intel® Dedicated Server Management NIC)	Yes
4	Reserved	Yes
5	USB	No
6	Secondary IPMB	No
7	SMM	No
8 – 0Dh	Reserved	–
0Eh	Self 2	–
0Fh	SMS/Receive Message Queue	No

Notes:

1. Optional hardware supported by the server system.
2. Refers to the actual channel used to send the request.

4.7.2 User Model

The BMC supports the IPMI 2.0 user model including *User ID 1* support. 15 user IDs are supported. These 15 users can be assigned to any channel. The following restrictions are placed on user-related operations:

1. User names for User IDs 1 and 2 cannot be changed. These are always "" (Null/blank) and "root" respectively.
 - i. A "CCh" error completion code is returned if a user attempts to modify these names.
2. User 2 ("root") always has the administrator privilege level.
 - i. A "CCh" error completion code is returned if a user attempts to modify this value.
 - ii. Trying to set any parameter for User ID 2 (root user) with the Set User Access command fails with a CCh completion code.
3. All user passwords (including passwords for 1 and 2) may be modified.
4. User IDs 3-15 may be used freely, with the condition that user names are unique. Therefore, no other users can be named "" (Null), "root," or any other existing user name.

Resetting a user name to a value equivalent to its current value results in a 0xCC error code. A list of default user values is given in Table 16. Default User Values.

Table 16. Default User Values

Users	User name	Password	Status	Default Privilege	Characteristics
User 1	[Null]	[Null]	Disabled	Admin	Password can be changed. This user may not be used to access the embedded web server.
User 2	root	superuser	Disabled	Admin	Password can be changed
User 3	test1	superuser	Disabled	Admin	User name and password can be changed
User 4	test2	superuser	Disabled	Admin	User name and password can be changed
User 5	test3	superuser	Disabled	Admin	User name and password can be changed
User 6-15	undefined	undefined	Disabled	Admin	User name and password can be changed

4.7.3 Sessions

The maximum number of IPMI-based sessions that can be supported by the BMC is returned as the byte 3 (number of possible active sessions) of the IPMI Command *Get Session Info* (App, 3Dh). Embedded Web Server and Media Redirection are not IPMI-based sessions. KVM is a type of payload in a RMCP+ Session.

Table 17. Channel/Media-specific minimum number of sessions

Channels/Media type	Session Type	Minimum Number of Sessions
LAN Channel1, Intel® Dedicated Server Management NIC ⁴	IPMI Over LAN ¹	4 ^{6,7}
HTTP ⁵	Embedded Web Server ³	2 ^{8,9}
--- ⁵	Media Redirection ^b	2 ⁸
--- ¹	KVM ²	2 ¹⁰

Notes:

1. Session type defined by the IPMI spec and includes RMCP and RMCP+ sessions (including all the payloads supported)
2. KVM is a RMCP+ **Payload Type**. Not an IPMI session.
3. These sessions are not defined by IPMI Specification and are not based on IPMI protocol. Counting them as IPMI Session violates the Specification.
4. If Intel® Dedicated Server Management NIC is not present, the minimum number of sessions still holds but only over LAN Channel 1.
5. It is not an IPMI Channel.
6. Maximum of 15 IPMI sessions are allowed per channel that is defined.

7. IPMI-based session and counted as an IPMI Session in all calculations.
8. These sessions are not counted as IPMI sessions. (For example, Get Session Info only returns values based on IPMI Sessions).
9. This type of Non-IPMI session can open IPMI sessions as part of a normal operation and those IPMI sessions are counted as IPMI sessions. For example, within a Web Session, one or more IPMI Over LAN Session are opened to GetandSet IPMI parameters. But since these IPMI sessions are not over LAN1 or Intel® Dedicated Server Management NIC, they are not counted as LAN1 or Intel® Dedicated Server Management NIC IPMI channel sessions but are counted as IPMI sessions in limit calculations.
10. It is an IPMI Over LAN RMCP+ session and is included in counts as part of the larger IPMI Over LAN group.

Note: The number of possible active session values returned by Get Session Info is the total number of allocated memory session slots in BMC firmware for IPMI Sessions. The actual number of IPMI sessions that can be established at any time is dependent on Channel and User IPMI configuration parameters and in compliance with the IPMI Specification, which is always less than the total available slots.

4.7.4 BMC LAN Channels

The BMC supports three RMII/RGMII ports that can be used for communicating with Ethernet devices. Two ports are used for communication with the on-board NICs and one is used for communication with an Ethernet PHY located on an optional add-in card (or equivalent on-board circuitry).

4.7.4.1 Baseboard NICs

The specific Ethernet controller (NIC) used on a server is platform-specific but all baseboard device options provide support for an NC-SI manageability interface. This provides a sideband high-speed connection for manageability traffic to the BMC while still allowing for a simultaneous host access to the OS if desired.

The Network Controller Sideband Interface (NC-SI) is a DMTF industry standard protocol for the side band management LAN interface. This protocol provides a fast multi-drop interface for management traffic.

The baseboard NIC(s) are connected to a single BMC RMII/RGMII port that is configured for RMII operation. The NC-SI protocol is used for this connection and provides a 100 Mb/s full-duplex multi-drop interface which allows multiple NICs to be connected to the BMC. The physical layer is based upon RMII, however RMII is a point-to-point bus whereas NC-SI allows 1 master and up to 4 slaves. The logical layer (configuration commands) is incompatible with RMII.

Multi-port baseboard NICs on some products will provide support for a dedicated management channel than can be configured to be hidden from the host and only used by the BMC. This mode of operation is configured through a BIOS setup option.

4.7.4.2 Dedicated Management Channel

An additional LAN channel dedicated to BMC usage and not available to host SW is supported through an optional add-in card. There is only a PHY device present on the add-in card. The BMC has a built-in MAC module that uses the RGMII interface to link with the card's PHY. Therefore, for this dedicated management interface, the PHY and MAC are located in different devices.

The PHY on the card connects to the BMC's other RMII/RGMII interface (that is the one that is not connected to the baseboard NICs). This BMC port is configured for RGMII usage.

In addition to the use of an add-in card for a dedicated management channel, on systems that support multiple Ethernet ports on the baseboard, the system BIOS provides a setup option to allow one of these baseboard ports to be dedicated to the BMC for manageability purposes. When this is enabled, that port is hidden from the OS.

4.7.4.3 Concurrent Server Management Use of Multiple Ethernet Controllers

Provided the HW supports a management link between the BMC and a NIC port, the BMC FW supports concurrent OOB LAN management sessions for the following combination:

- Two on-board NIC ports
- One on-board NIC and the optional dedicated add-in management NIC.
- Two on-board NICs and optional dedicated add-in management NIC.

All NIC ports must be on different subnets for the above concurrent usage models.

MAC addresses are assigned for management NICs from a pool of up to 3 MAC addresses allocated specifically for manageability. The total number of MAC addresses in the pool is dependent on the product HW constraints (for example a board with 2 NIC ports available for manageability would have a MAC allocation pool of 2 addresses).

For these channels, support can be enabled for IPMI-over-LAN and DHCP.

For security reasons, embedded LAN channels have the following default settings:

- IP Address: Static
- All users disabled

Network failover mode must be used for IPMI capable interfaces that are on the same subnet. Host-BMC communication over the same physical LAN connection – also known as “loopback” – is not supported. This includes “ping” operations.

On baseboards with more than two onboard NIC ports, only the first two ports can be used as BMC LAN channels. The remaining ports have no BMC connectivity.

- Maximum bandwidth supported by BMC LAN channels are as follows
- BMC LAN1 (Baseboard NIC port) — 1000M (10M in DC off state)
- BMC LAN 2 (Baseboard NIC port) — 1000M (10M in DC off state)
- BMC LAN 3 (Dedicated NIC) — 1000M

4.7.5 IPV6 Support

In addition to IPv4, the Intel® Server Board S2600WP supports IPv6 for manageability channels. Configuration of IPv6 is provided by extensions to the IPMI Set and Get LAN Configuration Parameters commands as well as through a Web Console IPv6 configuration web page.

The BMC supports IPv4 and IPv6 simultaneously so they are both configured separately and completely independently. For example, IPv4 can be DHCP configured while IPv6 is statically configured or vice versa. The parameters for IPv6 are similar to the parameters for IPv4 with the following differences:

- An IPv6 address is 16 bytes vs. 4 bytes for IPv4.
- An IPv6 prefix is 0 to 128 bits whereas IPv4 has a 4 byte subnet mask.
- The IPv6 Enable parameter must be set before any IPv6 packets will be sent or received on that channel.
- There are two variants of automatic IP Address Source configuration vs. just DHCP for IPv4.

The three possible IPv6 IP Address Sources for configuring the BMC are:

- **Static (Manual):** The IP, Prefix, and Gateway parameters are manually configured by the user. The BMC ignores any Router Advertisement messages received over the network.
- **DHCPv6:** The IP comes from running a DHCPv6 client on the BMC and receiving the IP from a DHCPv6 server somewhere on the network. The Prefix and Gateway are configured by Router Advertisements from the local router. The IP, Prefix, and Gateway are read-only parameters to the BMC user in this mode.
- **Stateless auto-config:** The Prefix and Gateway are configured by the router through Router Advertisements. The BMC derives its IP in two parts: the upper network portion comes from the router and the lower unique portion comes from the BMC's channel MAC address. The 6-byte MAC address is converted into an 8-byte value per the EUI-64* standard. For example, a MAC value of 00:15:17:FE:2F:62 converts into a EUI-64 value of 215:17ff:fefe:2f62. If the BMC receives a Router Advertisement from a router at IP 1:2:3:4:1 with a prefix of 64, it would then generate for itself an IP of 1:2:3:4:215:17ff:fefe:2f62. The IP, Prefix, and Gateway are read-only parameters to the BMC user in this mode.
- IPv6 can be used with the BMC's Web Console, JViewer (remote KVM and Media), and Systems Management Architecture for Server Hardware – Command Line Protocol (SMASH-CLP) interface (ssh). There is no standard yet on how IPMI RMCP or RMCP+ should operate over IPv6 so that is not currently supported.

4.7.5.1 LAN Failover

The BMC FW provides a LAN failover capability such that the failure of the system HW associated with one LAN link will result in traffic being rerouted to an alternate link. This functionality is configurable through IPMI methods as well as through the BMC's Embedded UI, allowing for user to specify the physical LAN links constitute the redundant network paths or physical LAN links constitute different network paths. BMC will support only an "all-or-nothing" approach – that is, all interfaces bonded together, or none are bonded together.

The LAN Failover feature applies only to BMC LAN traffic. It bonds all available Ethernet devices but only one is active at a time. When enabled, If the active connection's leash is lost, one of the secondary connections is automatically configured so that it has the same IP address. Traffic immediately resumes on the new active connection.

The LAN Failover enable/disable command may be sent at any time. After it has been enabled, standard IPMI commands for setting channel configuration that specify a LAN channel other than the first will return an error code.

4.8 System Event Log (SEL)

The BMC implements the system event log as specified in the *Intelligent Platform Management Interface Specification, Version 2.0*. The SEL is accessible regardless of the system power state through the BMC's in-band and out-of-band interfaces.

The BMC allocates 65,502 bytes (approximately 64KB) of non-volatile storage space to store system events. The SEL timestamps may not be in order. Up to 3,639 SEL records can be stored at a time. Any command that results in an overflow of the SEL beyond the allocated space is rejected with an "Out of Space" IPMI completion code (C4h).

4.8.1 Servicing Events

Events can be received while the SEL is being cleared. The BMC implements an event message queue to avoid the loss of messages. Up to three messages can be queued before messages are overwritten.

The BMC recognizes duplicate event messages by comparing sequence numbers and the message source. For details, see the *Intelligent Platform Management Interface Specification Second Generation v2.0*. Duplicate event messages are discarded (filtered) by the BMC after they are read from the event message queue. The queue can contain duplicate messages.

4.8.2 SEL Entry Deletion

The BMC does not support individual SEL entry deletion. The SEL may only be cleared as a whole.

4.8.3 SEL Erasure

SEL erasure is a background process. After initiating erasure with the *Clear SEL* command, additional *Clear SEL* commands must be executed to get the erasure status and determine when the SEL erasure is completed. This may take several seconds. SEL events that arrive during the erasure process are queued until the erasure is complete and then committed to the SEL.

SEL erasure generates an *Event Logging Disabled (Log Area Reset/Cleared offset)* sensor event.

4.8.4 SEL Extension Capabilities

The BMC provides an OEM extension to all SEL entries. Each entry includes an additional 8 bytes for storing extra event data that will not fit into the original 3 data bytes provided by standard IPMI SEL entries. The first extension byte is always valid for all SEL entries and specifies the severity of the SEL event as well as the number of valid extension bytes following the first one. That leaves up to 7 SEL extension data bytes that can be defined for each SEL event entry.

All standard IPMI SEL commands work the same as if there were no SEL extensions.

In order to store and access the extended SEL information, 5 OEM commands are implemented that closely follow the standard IPMI SEL commands but provide support for the SEL Extension data. These OEM commands are specified in the Intel® General Application Commands table.

4.9 Sensor Data Record (SDR) Repository

The BMC implements the sensor data record (SDR) repository as specified in the *Intelligent Platform Management Interface Specification, Version 2.0*. The SDR is accessible through the BMC's in-band and out-of-band interfaces regardless of the system power state. The BMC allocates 65,519 bytes of non-volatile storage space for the SDR.

4.10 Field Replaceable Unit (FRU) Inventory Device

The BMC implements the interface for logical FRU inventory devices as specified in the *Intelligent Platform Management Interface Specification, Version 2.0*. This functionality provides commands used for accessing and managing the FRU inventory information. These commands can be delivered through all interfaces.

The BMC provides FRU device command access to its own FRU device and to the FRU devices throughout the server. The FRU device ID mapping is defined in the Platform Specific Information. The BMC controls the mapping of the FRU device ID to the physical device.

4.11 Diagnostics and Beep Code Generation

The BMC may generate beep codes upon detection of failure conditions. Beep codes are sounded each time the problem is discovered (for example, on each power-up attempt), but are not sounded continuously. Common supported codes are listed in Table 18.

Additional platform-specific beep codes can be found in the appropriate Platform Specific Information. Each digit in the code is represented by a sequence of beeps whose count is equal to the digit.

Table 18. BMC Beep Codes

Code	Reason for Beep	Associated Sensors	Supported
1-5-2-1	No CPUs installed or first CPU socket is empty.	CPU Missing Sensor	Yes
1-5-2-4	MSID Mismatch.	MSID Mismatch Sensor.	Yes
1-5-4-2	Power fault: DC power is unexpectedly lost (power good dropout).	Power unit – power unit failure offset.	Yes
1-5-4-4	Power control fault (power good assertion timeout).	Power unit – soft power control failure offset.	Yes
1-5-1-2	VR Watchdog Timer sensor assertion	VR Watchdog Timer	Yes
1-5-1-4	The system does not power on or unexpectedly powers off and a power supply unit (PSU) is present that is an incompatible model with one or more other PSUs in the system	PSU status	Yes

4.12 Diagnostics Interrupt (NMI)

The BMC generates an NMI pulse under certain conditions. The BMC-generated NMI pulse duration is at least 30ms. Once an NMI has been generated by the BMC, the BMC does not generate another NMI until the system has been reset or powered down.

The following actions cause the BMC to generate an NMI pulse:

- Receiving a Chassis Control command to pulse the diagnostic interrupt. This command does not cause an event to be logged in the SEL.
- Detecting that the front panel diagnostic interrupt button has been pressed.
- Watchdog timer pre-timeout expiration with NMI/diagnostic interrupt pre-timeout action enabled.

Table 19 shows behavior regarding NMI signal generation and event logging by the BMC.

Table 19. NMI Signal Generation and Event Logging

Causal Event	NMI (IA-32 Only)	
	Signal Generation	Front Panel Diag Interrupt Sensor Event Logging Support
Chassis Control command (pulse diagnostic interrupt)	X	–
Front panel diagnostic interrupt button pressed	X	X
Watchdog Timer pre-timeout expiration with NMI/diagnostic interrupt action	X	–

4.13 BMC Basic and Advanced Management Features

The Intel® Server Board S2600WP product includes support for an upgrade module to support the advanced server management functionality.

Table 20. Basic and Advanced Management Features

Feature	Basic*	Advanced**
IPMI 2.0 Feature Support	X	X
In-circuit BMC Firmware Update	X	X
FRB 2	X	X
Fan Redundancy Monitoring	X	X
Hot-Swap Fan Support	X	X
Acoustic Management	X	X
Diagnostic Beep Code Support	X	X
Power State Retention	X	X
ARP/DHCP Support	X	X
PECI Thermal Management Support	X	X
E-mail Alerting	X	X
Embedded Web Server	X	X

Feature	Basic*	Advanced**
SSH Support	X	X
Integrated KVM		X
Integrated Remote Media Redirection		X
Local Directory Access Protocol (LDAP)	X	X
Intel® Intelligent Power Node Manager Support***	X	X
SMASH CLP	X	X

* Basic management features provided by Integrated BMC

**Advanced management features available with optional Intel® Remote Management Module 4 Lite

***Intel® Intelligent Power Node Manager Support requires PMBus*-compliant power supply

4.13.1 Enabling Advanced Manageability Features

The Advanced management features are to be delivered as part of the BMC FW image. The BMC's baseboard SPI flash contains code/data for both the Basic and Advanced features. An optional module Intel® RMM4 Lite is used as the activation mechanism. When the BMC FW initializes, it attempts to access the Intel® RMM4 lite. If the attempt to access Intel® RMM4 Lite is successful, then the BMC activates the advanced features.

Advanced manageability features are supported over all NIC ports enabled for server manageability. This includes baseboard NICs as well as the LAN channel provided by the optional Dedicated NIC add-in card.

Table 21. Management features and Benefits

Manageability Hardware	Benefits
Intel® Integrated BMC	Comprehensive IPMI based base manageability features
Intel® Remote Management Module4 – Lite Package contains one module – Key for advance Manageability features.	No dedicated NIC for management Enables KVM and media redirection through onboard NIC
Intel® Remote Management4 Module Package includes 2 modules – Key for advance features Dedicated NIC (1Gbe) for management	Dedicated NIC for management traffic. Higher bandwidth connectivity for KVM and media Redirection with 1Gbe NIC.

4.13.1.1 Keyboard, Video and Mouse (KVM) Redirection

The BMC firmware supports keyboard, video, and mouse redirection (KVM) over LAN. This feature is available remotely from the embedded web server as a Java applet. This feature is enabled when the Intel® RMM4 Lite is present. The client system must have a Java Runtime Environment (JRE) version 5.0 or later to run the KVM or media redirection applets.

The Integrated BMC supports an embedded KVM application (Remote Console) that can be launched from the embedded web server from a remote console. USB1.1 or USB 2.0 based mouse and keyboard redirection are supported. It is also possible to use the KVM-redirection (KVM-r) session concurrently with media-redirection (media-r). This feature allows a user to

interactively use the keyboard, video, and mouse (KVM) functions of the remote server as if the user were physically at the managed server.

The KVM-redirection feature automatically senses video resolution for best possible screen capture and provides high-performance mouse tracking and synchronization. It allows remote viewing and configuration in pre-boot POST and BIOS setup, once BIOS has initialized video.

Other attributes of this feature include:

- Encryption of the redirected screen, keyboard, and mouse
- Compression of the redirected screen

4.13.1.2 Remote Console

The Remote Console is the redirected screen, keyboard and mouse of the remote host system. To use the Remote Console window of your managed host system, the browser must include a Java® Runtime Environment plug-in. If the browser has no Java support, such as with a small handheld device, the user can maintain the remote host system using the administration forms displayed by the browser.

The Remote Console window is a Java Applet that establishes TCP connections to the Integrated BMC. The protocol that is run over these connections is a unique KVM protocol and not HTTP or HTTPS. This protocol uses ports #7578 for KVM, #5120 for CDROM media redirection, and #5123 for Floppy/USB media redirection (both supporting encryption).

4.13.1.3 Performance

The remote display accurately represents the local display. The feature adapts to changes to the video resolution of the local display and continues to work smoothly when the system transitions from graphics to text or vice-versa. The responsiveness may be slightly delayed depending on the bandwidth and latency of the network.

Enabling KVM and/or media encryption will degrade performance. Enabling video compression provides the fastest response while disabling compression provides better video quality.

For the best possible KVM performance, a 2Mb/sec link or higher is recommended.

The redirection of KVM over IP is performed in parallel with the local KVM without affecting the local KVM operation.

4.13.1.4 Security

The KVM redirection feature supports multiple encryption algorithms, including RC4 and AES. The actual algorithm that is used is negotiated with the client based on the client's capabilities.

4.13.1.5 Availability

The remote KVM session is available even when the server is powered-off (in stand-by mode). No re-start of the remote KVM session shall be required during a server reset or power on/off. An Integrated BMC reset (for example due to an Integrated BMC Watchdog initiated reset or Integrated BMC reset after Integrated BMC firmware update) will require the session to be re-established.

KVM sessions persist across system reset, but not across an AC power loss.

4.13.1.6 Timeout

The remote KVM session will automatically timeout after a configurable amount of time (30 minutes is the default).

The default inactivity timeout is 30 minutes, but may be changed through the embedded web server. Remote KVM activation does not disable the local system keyboard, video, or mouse. Remote KVM is not deactivated by local system input, unless the feature is disabled locally.

4.13.1.7 Usage

As the server is powered up, the remote KVM session displays the complete BIOS boot process. The user is able to interact with BIOS setup, change and save settings as well as enter and interact with option ROM configuration screens.

At least two concurrent remote KVM sessions are supported. It is possible for at least two different users to connect to same server and start remote KVM sessions

4.13.2 Media Redirection

The embedded web server provides a Java applet to enable remote media redirection. This may be used in conjunction with the remote KVM feature, or as a standalone applet.

The media redirection feature is intended to allow system administrators or users to mount a remote IDE or USB CD-ROM, floppy drive, or a USB flash disk as a remote device to the server. Once mounted, the remote device appears just like a local device to the server, allowing system administrators or users to install software (including operating systems), copy files, update BIOS, and so on, or boot the server from this device.

The following capabilities are supported:

- The operation of remotely mounted devices is independent of the local devices on the server. Both remote and local devices are useable in parallel.
- Either IDE (CD-ROM, floppy) or USB devices can be mounted as a remote device to the server.
- It is possible to boot all supported operating systems from the remotely mounted device and to boot from disk IMAGE (*.IMG) and CD-ROM or DVD-ROM ISO files. See the Tested/supported Operating System List for more information.
- Media redirection shall support redirection for a minimum of two virtual devices concurrently with any combination of devices. As an example, a user could redirect two CD or two USB devices.
- The media redirection feature supports multiple encryption algorithms, including RC4 and AES. The actual algorithm that is used is negotiated with the client based on the client's capabilities.
- A remote media session is maintained even when the server is powered-off (in standby mode). No restart of the remote media session is required during a server reset or power on/off. An Integrated BMC reset (for example due to an Integrated BMC reset after Integrated BMC firmware update) will require the session to be re-established

- The mounted device is visible to (and useable by) managed system's OS and BIOS in both pre-boot and post-boot states.
- The mounted device shows up in the BIOS boot order and it is possible to change the BIOS boot order to boot from this remote device.
- It is possible to install an operating system on a bare metal server (no OS present) using the remotely mounted device. This may also require the use of KVM-r to configure the OS during install.
- USB storage devices will appear as floppy disks over media redirection. This allows for the installation of device drivers during OS installation.
- If either a virtual IDE or virtual floppy device is remotely attached during system boot, both the virtual IDE and virtual floppy are presented as bootable devices. It is not possible to present only a single-mounted device type to the system BIOS.

Note: When trying to attach a local floppy or local USB key drive, if it is in use by the operating system or any other application it will fail to attach.

With Microsoft Windows 2008*, Microsoft Windows 2008R2*, and Microsoft Windows 7* if a Windows Explorer* GUI is opened after the USB Key has been installed in the local system, you may not be able to attach the USB Key as remote media.

With Microsoft Windows 2003*, and Microsoft Windows XP* if a Windows Explorer* GUI is opened after the USB Key has been installed in the local system and you then browse through the USB Key, you may not be able to attach the USB Key as remote media.

4.13.2.1 Availability

The default inactivity timeout is 30 minutes and is not user-configurable.

Media redirection sessions persist across system reset but not across an AC power loss or BMC reset.

4.13.2.2 Network Port Usage

The KVM and media redirection features use the following ports:

- 5120 – CD Redirection
- 5123 – FD Redirection
- 5124 – CD Redirection (Secure)
- 5127 – FD Redirection (Secure)
- 7578 – Video Redirection
- 7582 – Video Redirection (Secure)

4.13.3 Embedded Web server

Integrated BMC Base manageability provides an embedded web server and an OEM-customizable web GUI which exposes the manageability features of the Integrated BMC base feature set. It is supported over all on-board NICs that have management connectivity to the Integrated BMC as well as an optional dedicated add-in management NIC. At least two

concurrent web sessions from up to two different users is supported. The embedded web user interface shall support the following client web browsers:

- Microsoft Internet Explorer 7.0*
- Microsoft Internet Explorer 8.0*
- Microsoft Internet Explorer 9.0*
- Mozilla Firefox 3.0*
- Mozilla Firefox 3.5*
- Mozilla Firefox 3.6*

The embedded web user interface supports strong security (authentication, encryption, and firewall support) since it enables remote server configuration and control. The user interface presented by the embedded web user interface shall authenticate the user before allowing a web session to be initiated. Encryption using 128-bit SSL is supported. User authentication is based on user id and password.

The GUI presented by the embedded web server authenticates the user before allowing a web session to be initiated. It presents all functions to all users but grays-out those functions that the user does not have privilege to execute. (for example if a user does not have privilege to power control, then the item shall be displayed in grey-out font in that user's UI display). The web GUI also provides a launch point for some of the advanced features, such as KVM and media redirection. These features are grayed out in the GUI unless the system has been updated to support these advanced features.

A partial list of additional features supported by the web GUI includes:

- Presents all the Basic features to the users.
- Power on/off/reset the server and view current power state.
- Virtual front panel display and overall system health.
- Provides embedded firmware version information.
- Configuration of various IPMI parameters (LAN parameters, users, passwords, and so on.)
- Configuration of alerting (SNMP and SMTP).
- Display system asset information for the product, board, and chassis.
- Display of BMC-owned sensors (name, status, current reading, enabled thresholds), including color-code status of sensors.
- Automatic refresh of sensor data with a configurable refresh rate.
- On-line help.
- Display/clear SEL (display is in easily understandable human readable format).
- Supports major industry-standard browsers (Internet Explorer and Mozilla Firefox).
- Automatically logs out after user-configurable inactivity period.
- The GUI session automatically times-out after a user-configurable inactivity period. By default, this inactivity period is 30 minutes.

- Embedded Platform Debug feature - Allow the user to initiate a “diagnostic dump” to a file that can be sent to Intel® for debug purposes.
- Display of power statistics (current, average, minimum, and maximum) consumed by the server.

4.13.4 Data Center Management Interface (DCMI)

The DCMI Specification is an emerging standard that is targeted to provide a simplified management interface for Internet Portal Data Center (IPDC) customers. It is expected to become a requirement for server platforms which are targeted for IPDCs. DCMI is an IPMI-based standard that builds upon a set of required IPMI standard commands by adding a set of DCMI-specific IPMI OEM commands. S2600CP platforms will be implementing the mandatory DCMI features in the BMC FW (DCMI 1.1 Errata 1 compliance).

4.13.5 Local Directory Authentication Protocol (LDAP)

The Lightweight Directory Access Protocol (LDAP) is an application protocol supported by the Integrated BMC for the purpose of authentication and authorization. The Integrated BMC user connects with an LDAP server for login authentication. This is only supported for non-IPMI logins including the embedded web UI and SM-CLP. IPMI users/passwords and sessions are not supported over LDAP.

LDAP can be configured (IP address of LDAP server, port, and so on.) through the Integrated BMC's Embedded Web UI. LDAP authentication and authorization is supported over the any NIC configured for system management. The BMC uses a standard Open LDAP implementation for Linux*.

4.13.6 Platform/Chassis Management

Within an IPMI 2.0 framework, the BMC Firmware provides functionality to support management and control of several aspects of the platform operation. This includes:

- **Front Panel Support** (for example, secure lock out of power and reset buttons and System Status LED control)
- **Hardware/Sensor Monitoring** (for example system voltages, thermal sensors, fans, power supplies, and so on)
- **Power/Reset Control and Monitoring** (for example, local and remote power/reset control and power restore policy)
- **Hardware and Manufacturing Test Features**
- **Asset Inventory and System Identification** (for example, system GUID and FRU management)
- **Thermal and Acoustics Management** – The BMC firmware provides a comprehensive set of fan control capabilities utilizing various system thermal sensors (for example CPU, DIMMs, front panel thermal sensor). Additionally, the BMC participates in the memory CLTT by pushing dim thermal data to the iMC in the CPU.
- **Power Management (Node Manager) Support** – BMC firmware provides an external (LAN) interface for a remote management console to communicate with the ME's Node Manager Functionality.

4.13.7 Thermal Control

The system shall support thermal management through open loop throttling (OLTT) or static closed loop throttling (CLTT) of system memory based on availability of valid temperature sensors on the installed memory DIMMs. The Integrated Memory Controller (IMC) dynamically changes throttling levels to cap throttling based on memory and system thermal conditions as determined by the system and DIMM power and thermal parameters. Support for CLTT on mixed-mode DIMM populations (that is, some installed DIMMs have valid temp sensors and some do not) is not supported. The Integrated BMC fan speed control functionality is related to the memory throttling mechanism used.

The following terminology is used for the various memory throttling options:

- **Static Open Loop Thermal Throttling (Static-OLTT):** OLTT control registers are configured by BIOS MRC remain fixed after post. The system does not change any of the throttling control registers in the embedded memory controller during runtime.
- **Static Closed Loop Thermal Throttling (Static-CLTT):** CLTT control registers are configured by BIOS MRC during POST. The memory throttling is run as a closed-loop system with the DIMM temperature sensors as the control input. Otherwise, the system does not change any of the throttling control registers in the embedded memory controller during runtime.
- **Dynamic Open Loop Thermal Throttling (Dynamic-OLTT):** OLTT control registers are configured by BIOS MRC during POST. Adjustments are made to the throttling during runtime based on changes in system cooling (fan speed).
- **Dynamic Closed Loop Thermal Throttling (Dynamic-CLTT):** CLTT control registers are configured by BIOS MRC during POST. The memory throttling is run as a closed-loop system with the DIMM temperature sensors as the control input. Adjustments are made to the throttling during runtime based on changes in system cooling (fan speed).

4.13.7.1 Fan Speed Control

BIOS and BMC software work cooperatively to implement system thermal management support. During normal system operation, the BMC will retrieve information from the BIOS and monitor several platform thermal sensors to determine the required fan speeds.

In order to provide the proper fan speed control for a given system configuration, the BMC must have the appropriate platform data programmed. Platform configuration data is programmed using the FRUSDR utility during the system integration process and by System BIOS during run time.

Table 22. Fan Profile Mapping

Type	Profile	Details
OLTT	0	Acoustic, 300M altitude
OLTT	1	Performance, 300M altitude
OLTT	2	Acoustic, 900M altitude
OLTT	3	Performance, 900M altitude
OLTT	4	Acoustic, 1500M altitude

Type	Profile	Details
OLTT	5	Performance, 1500M altitude
OLTT	6	Acoustic, 3000M altitude
OLTT	7	Performance, 3000M altitude
CLTT	0	300M altitude
CLTT	2	900M altitude
CLTT	4	1500M altitude
CLTT	6	3000M altitude

4.13.7.2 System Configuration Using FRUSDR Utility

The Field Replaceable Unit and Sensor Data Record Update Utility (FRUSDR utility) is a program used to write platform-specific configuration data to NVRAM on the server board. It allows the user to select which supported chassis (Intel® or Non-Intel®) and platform chassis configuration is used. Based on the input provided, the FRUSDR writes sensor data specific to the configuration to NVRAM for the BMC controller to read each time the system is powered on.

4.13.8 Node Power On/Off Control

The BMC on each node will monitor its fans and temperature for a critical failure. When a critical failure occurs the node will be powered down by BMC. When this occurs the node will need to be manually powered on.

4.14 Intel® Intelligent Power Node Manager

4.14.1 Overview

Power management deals with requirements to manage processor power consumption and manage power at the platform level to meet critical business needs. Node Manager (NM) is a platform resident technology that enforces power capping and thermal-triggered power capping policies for the platform. These policies are applied by exploiting subsystem knobs (such as processor P and T states) that can be used to control power consumption. NM enables data center power management by exposing an external interface to management software through which platform policies can be specified. It also implements specific data center power management usage models such as power limiting, and thermal monitoring.

Note: Support for Node Manager is product-specific. This section details how Node Manager would be supported on products that provide this capability.

The NM feature is implemented by a complementary architecture utilizing the ME, BMC, BIOS, and an ACPI-compliant OS. The ME provides the NM policy engine and power control/limiting functions (referred to as Node Manager or NM) while the BMC provides the external LAN link by which external management software can interact with the feature. The BIOS provides system power information utilized by the NM algorithms and also exports ASL code used by OSPM for negotiating processor P and T state changes for power limiting. PMBus*-compliant power supplies provide the capability to monitoring input power consumption, which is necessary to support NM.

The NM architecture applicable to this generation of servers is defined by the *NPTM Architecture Specification v2.0*. NPTM is an evolving technology that is expected to continue to add new capabilities that will be defined in subsequent versions of the specification. The ME NM implements the NPTM policy engine and control/monitoring algorithms defined in the NPTM specification.

4.14.2 Features

NM provides feature support for policy management, monitoring and querying, alerts and notifications, and an external interface protocol. The policy management features implement specific IT goals that can be specified as policy directives for NM. Monitoring and querying features enable tracking of power consumption. Alerts and notifications provide the foundation for automation of power management in the data center management stack. The external interface specifies the protocols that must be supported in this version of NM.

The role of BMC in Node Manager will include:

- External communication links
- Command passing through BMC
- Alerting
- BIOS-BMC-ME communication

4.15 Management Engine (ME)

4.15.1 Overview

The Intel® Server Platform Services (SPS) is a set of manageability services provided by the firmware executing on an embedded ARC controller within the IOH. This management controller is also commonly referred to as the Management Engine (ME). The functionality provided by the SPS firmware is different from Intel® Active Management Technology (Intel® AMT or AT) provided by the ME on client platforms.

Server Platform Services (SPS) are value-added platform management options that enhance the value of Intel® platforms and their component ingredients (CPUs, chipsets, and I/O components). Each service is designed to function independently wherever possible, or grouped together with one or more features in flexible combinations to allow OEMs to differentiate platforms.

4.15.2 BMC - Management Engine (ME) Distributed Model

The Intel® Server Board S2600WP covered in this specification will require Node Manager 2.0 (NM2.0) support. The following management architecture would need to be supported on the baseboard to meet product and validation requirements. The NM 2.0 functionality is provided by the Intel® C600-A PCH Management Engine (ME).

The server management architecture is a partitioned model which places the Management Engine, which is an embedded controller in the Intel® C600-A PCH, in between the BMC and the processors. In this architecture, the PCH Management Engine is the owner of the PECCI 3.0 bus and the ServerEngines* Pilot III BMC communicates with the ME through a SMBus* connection (SMLINK 0.) The ME provides PECCI proxy support that allows the ServerEngines* Pilot III BMC firmware to access processor functions available on the PECCI bus.

The primary function of ME is to implement the NM 2.0 feature set. In this architectural model, the ServerEngines® Pilot III BMC provides the external (LAN) interface to ME in the form of IPMI bridging. A remote Node Manager application would establish a management session with the ServerEngines® Pilot III BMC which in turn would bridge IPMI commands through the secondary IPMB to the ME. In this scenario, the ServerEngines® Pilot III BMC simply acts as a proxy for this communication pipe. The ME may also generate alerts to the ServerEngines® Pilot III BMC, which may log these into the system SEL and/or output them to the remote application in the form of IPMI LAN alerts.

The ServerEngines® Pilot III BMC needs access to various system registers in the processor core silicon and integrated memory controller subsystem. Examples include Processor core and Memory DIMMs temperature information. The ServerEngines® Pilot III BMC requires this information as input into its fan speed control algorithms. The ServerEngines® Pilot III BMC accesses these registers through the secondary IPMB bus connection to ME. Depending on the particular data or register access needed, this is done using either the ME's PECE proxy functionality or through an abstracted data construct provided by the ME.

Also in this architecture, both the ServerEngines® Pilot III BMC and the ME are connected to the system power supplies through a common PMBus® (SMBus® physical) connection (SMLINK 1.) The ME accesses the system power supplies in support of various NM 2.0 features. The ServerEngines® Pilot III BMC monitors the power supplies in support of various power-related telemetry and status information that is exposed as IPMI sensors.

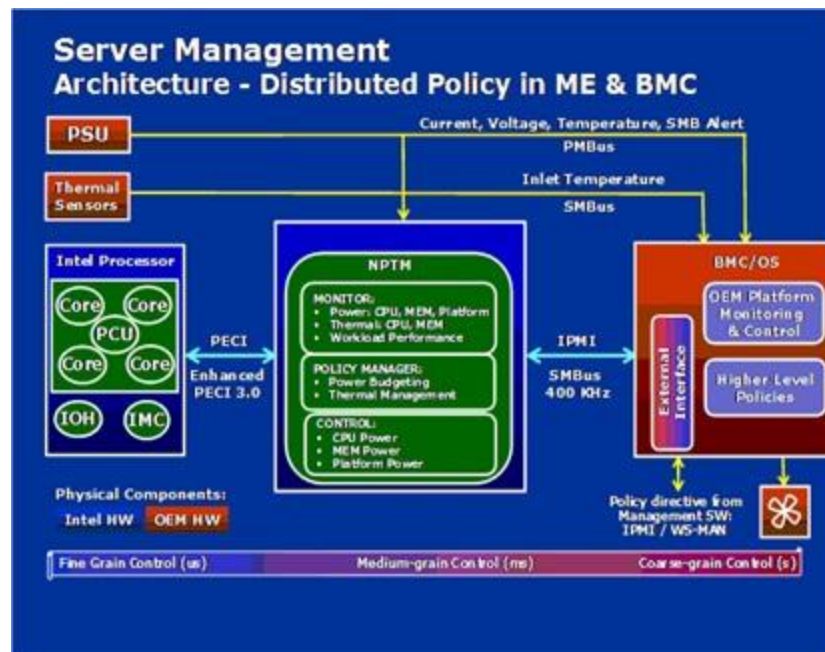

Figure 22. Management Engine Distribution Model

4.15.3 ME System Management Bus (SMBus®) Interface

- The ME uses the SMLink0 on the SSB in multi-master mode as a dedicated bus for communication with the BMC using the IPMB protocol. The EPSD BMC FW considers this a secondary IPMB bus and runs at 400KHz.
- The ME uses the SMLink1 on the SSB in multi-master mode bus for communication with PMBus® devices in the power supplies for support of various NM-related features. This

bus is shared with the BMC, which polls these PMBus* power supplies for sensor monitoring purposes (for example power supply status, input power, and so on.). This bus runs at 100 KHz.

- The Management Engine has access to the “Host SMBus*”.

4.15.4 BMC - Management Engine Interaction

Management Engine-Integrated BMC interactions include the following:

- Integrated BMC stores sensor data records for ME-owned sensors.
- Integrated BMC participates in ME firmware update.
- Integrated BMC initializes ME-owned sensors based on SDRs.
- Integrated BMC receives platform event messages sent by the ME.
- Integrated BMC notifies ME of POST completion.
- BMC may be queried by the ME for inlet temperature readings

4.15.5 ME Power and Firmware Startup

On Intel® Server Board S2600WP, the ME is on standby power. The ME FW will begin its startup sequence at the same time that the BMC FW is booting. As the BMC FW is booting to a Linux kernel and the ME FW uses an RTOS, the ME FW should always complete its basic initialization before the BMC. The ME FW can be configured to send a notification message to the BMC. After this point, the ME FW is ready to process any command requests from the BMC.

In S0/S1 power states, all ME FW functionality is supported. Some features, such as power limiting, are not supported in S3/S4/S5 power states. Refer to ME FW documentation for details on what is not supported while in the S3/S4/S5 states.

The ME FW uses a single operational image with a limited-functionality recovery image. In order to upgrade an operational image, a boot to recovery image must be performed. The ME FW does not support an IPMI update mechanism except for the case that the system is configured with a dual-ME (redundant) image. In order to conserve flash space, which the ME FW shares with BIOS, EPSP systems only support a single ME image. For this case, ME update is only supported by means of BIOS performing a direct update of the flash component. The recovery image only provides the basic functionality that is required to perform the update; therefore other ME FW features are not functional therefore when the update is in progress.

4.15.6 SmARt/CLST

The power supply optimization provided by SmARt/CLST relies on a platform HW capability as well as ME FW support. When a PMBus*-compliant power supply detects insufficient input voltage, an over current condition, or an over-temperature condition, it will assert the SMBAlert# signal on the power supply SMBus* (also known as the PMBus*). Through the use of external gates, this results in a momentary assertion of the PROCHOT# and MEMHOT# signals to the processors, thereby throttling the processors and memory. The ME FW also sees the SMBAlert# assertion, queries the power supplies to determine the condition causing the assertion, and applies an algorithm to either release or prolong the throttling, based on the situation.

System power control modes include:

- **SmArT:** Low AC input voltage event; results in a onetime momentary throttle for each event to the maximum throttle state
- **Electrical Protection CLST:** High output energy event; results in a throttling hiccup mode with fixed maximum throttle time and a fix throttle release ramp time.
- **Thermal Protection CLST:** High power supply thermal event; results in a throttling hiccup mode with fixed maximum throttle time and a fix throttle release ramp time.

When the SMBAlert# signal is asserted, the fans will be gated by HW for a short period (~100ms) to reduce overall power consumption. It is expected that the interruption to the fans will be of short enough duration to avoid false lower threshold crossings for the fan tach sensors; however, this may need to be comprehended by the fan monitoring FW if it does have this side-effect.

4.16 Other Platform Management

The platform supports the following sleep states, S1 and S5. Within S0, the platform supports additional lower power states, such as C1e and C6, for the CPU.

4.16.1 Wake On LAN (WOL)

- Wake On LAN (WOL) is supported on both LAN ports and IOM LAN modules for all supported Sleep states.
- Wake on Ring is supported on the external Serial port only for all supported Sleep states.
- Wake on USB is supported on the rear and front panel USB ports for S1 only.
- Wake on RTC is supported for all supported Sleep states.
- Wake IPMI command is supported (BMC function no additional hardware requirement) for all supported Sleep states.

4.16.2 PCI Express* Power management

L0 and L3 power management states are supported on all PCI Express* slots and embedded end points.

4.16.3 PMBus*

Power supplies that have PMBus* 1.1 are supported and required to support Intel® Dynamic Power Node Manager. Intel® Server Board S2600WP supports the features of Intel® Dynamic Power Node Manager version 1.5 except the inlet temperature sensor.

4.16.4 Node Power Policies

When working with Intel® Server Chassis H2000JF, the BMC on each node will monitor its fans and temperature for critical failures. When there is a fan failure and a critical temperature event at the same time the node will be powered down. When this occurs the node will need to be manually powered back on.

Additionally on Intel® Server Board S2600JF, the BMC on **node 3** and **node 4** will monitor for a power supply over current condition or power supply over temperature condition. If either of these occur and the Shutdown Policy has been enabled then the node will be powered down.

When this occurs the node will need to be manually powered back on but if the over current or over temperature event is detected again the node will be powered back off.

The Shutdown Policy setting is only shown on Node 3 and Node 4, and is disabled by default but can be enabled or disabled in the BIOS setup Server Management page or by using the Set Shutdown Policy command.

5. BIOS Setup Interface

5.1 HotKeys Supported During POST

Certain “HotKeys” are recognized during POST. A HotKey is a key or key combination that is recognized as an unprompted command input, that is, the operator is not prompted to press the HotKey and typically the HotKey will be recognized even while other processing is in progress.

The Intel® Server Board S2600JF Family BIOS recognizes a number of HotKeys during POST. After the OS is booted, HotKeys are the responsibility of the OS and the OS defines its own set of recognized HotKeys.

Following are the POST HotKeys, with the functions they cause to be performed.

Table 23. POST HotKeys Recognized

HotKey Combination	Function
<F2>	Enter Setup
<F6>	Pop up BIOS Boot Menu
<F12>	Network boot

5.2 POST Logo/Diagnostic Screen

The logo/Diagnostic Screen displays in one of two forms:

- If Quiet Boot is enabled in the BIOS setup, a logo splash screen displays. By default, Quiet Boot is enabled in the BIOS setup. If the logo displays during POST, press <Esc> to hide the logo and display the diagnostic screen.
- If a logo is not present in the flash ROM or if Quiet Boot is disabled in the system configuration, the POST Diagnostic Screen is displayed with a summary of system configuration information.
- The diagnostic screen displays the following information:
 - “Copyright <year> Intel Corporation”
 - AMI Copyright statement
 - BIOS version (ID)
 - BMC firmware version
 - SDR version
 - ME firmware version
 - Platform ID
 - System memory detected (total size of all installed DDR3 DIMMs)
 - Current memory speed (currently configured memory operating frequency)
 - Processor information (Intel Brand String identifying type of processor and nominal operating frequency, and number of physical processors identified)
 - Keyboards detected, if any attached
 - Mouse devices detected, if any attached

- Instructions showing hotkeys for going to Setup, going to popup Boot Menu, starting Network Boot

5.3 BIOS Boot Pop-up Menu

The BIOS Boot Specification (BBS) provides a Boot Pop-up menu that can be invoked by pressing the <F6> key during POST. The BBS Pop-up menu displays all available boot devices. The boot order in the pop-up menu is not the same as the boot order in the BIOS setup. The pop-up menu simply lists all of the available devices from which the system can be booted, and allows a manual selection of the desired boot device.

When an Administrator password is installed in Setup, the Administrator password will be required in order to access the Boot Pop-up menu using the <F6> key. If a User password is entered, the Boot Pop-up menu will not even appear – the user will be taken directly to the Boot Manager in the Setup, where a User password allows only booting in the order previously defined by the Administrator.

5.4 BIOS Setup Utility

The BIOS Setup utility is a text-based utility that allows the user to configure the system and view current settings and environment information for the platform devices. The Setup utility controls the platform's built-in devices, the boot manager, and error manager.

The BIOS Setup interface consists of a number of pages or screens. Each page contains information or links to other pages. The advanced tab in Setup displays a list of general categories as links. These links lead to pages containing a specific category's configuration.

The following sections describe the look and behavior for the platform setup.

5.4.1 BIOS Setup Operation

The BIOS Setup Utility has the following features:

- Localization – The Intel® Server Board BIOS is only available in English. However, BIOS Setup uses the Unicode standard and is capable of displaying data and input in Setup fields in all languages currently included in the Unicode standard.
- Console Redirection – BIOS Setup is functional through Console Redirection over various terminal emulation standards. This may limit some functionality for compatibility, for example, usage of colors or some keys or key sequences or support of pointing devices.
- Setup screens are designed to be displayable in an 80-character x 24-line format in order to work with Console Redirection, although that screen layout should display correctly on any format with longer lines or more lines on the screen.
- Password protection – BIOS Setup may be protected from unauthorized changes by setting an Administrative Password in the Security screen. When an Administrative Password has been set, all selection and data entry fields in Setup (except System Time and Date) are grayed out and cannot be changed unless the Administrative Password has been entered.

Note: if an Administrative Password has **not** been set, anyone who boots the system to Setup has access to all selection and data entry fields in Setup and can change any of them. For more information about BIOS password protection.

5.4.1.1 Setup Page Layout

The Setup page layout is sectioned into functional areas. Each occupies a specific area of the screen and has dedicated functionality. The following table lists and describes each functional area.

The Setup page is designed to a format of 80 x 24 (24 lines of 80 characters each). The typical display screen in a Legacy mode or in a terminal emulator mode is actually 80 characters by 25 lines, but with “line wrap” enabled (which it usually is) the 25th line cannot be used with the Setup page.

Table 24. BIOS Setup Page Layout

Functional Area	Description
Title (Tab) Bar	<p>The Title Bar is located at the top of the screen and displays “Tabs” with the titles of the top-level pages, or screens that can be selected. Using the left and right arrow keys moves from page to page through the Tabs.</p> <p>When there are more Tabs than can be displayed on the Title (Tab) Bar, they will scroll off to the left or right of the screen and temporarily disappear from the visible Title Bar. Using the arrow keys will scroll them back onto the visible Title Bar. When the arrow keys reach either end of the Title Bar, they will “wrap around” to the other end of the Title Bar.</p> <p>For multi-level hierarchies, this shows only the top-level page above the page which the user is currently viewing. The Page Title gives further information.</p>
Page Title	<p>In a multi-level hierarchy of pages beneath one of the top-level Tabs, the Page Title identifying the specific page which the user is viewing is located in the upper left corner of the page. Using the <ESC> (Escape) key will return the user to the higher level in the hierarchy, until the top-level Tab page is reached.</p>
Setup Item List	<p>The Setup Item List is a set of control entries and informational items. The list is displayed in two columns. For each item in the list:</p> <ul style="list-style-type: none"> ▪ The left column of the list contains Prompt String (or Label String), a character string which identifies the item. The Prompt String may be up to 34 characters long in the 80 x 24 page format. ▪ The right column contains a data field which may be an informational data display, a data input field, or a multiple choice field. Data input or multiple-choice fields are demarcated by square brackets (“[...]”). This field may be up to 90 characters long, but only the first 22 characters can be displayed on the 80 x 24 page (24 characters for an informational display-only field). <p>The operator navigates up and down the right hand column through the available input or choice fields.</p> <p>A Setup Item may also represent a selection to open a new screen with a further group of options for specific functionality. In this case, the operator navigates to the desired selection and presses <Enter> to go to the new screen.</p>
Item-Specific Help Area	<p>The Item-specific Help Area is located on the right side of the screen and contains Help Text specific to the highlighted Setup Item. Help information may include the meaning and usage of the item, allowable values, effects of the options, and so on.</p> <p>The Help Area is a 29 character by 11 line section of the 80 x 24 page. The Help Text may have explicit line-breaks within it. When the text is longer than 29 characters, it is also broken to a new line, dividing the text at the last space (blank) character before the 29th character. An unbroken string of more than 29 character will be arbitrarily wrapped to a new line after the 29th character. Text that extends beyond the end of the 11th line will not be displayed.</p>
Keyboard Command Area	<p>The Keyboard Command Area is located at the bottom right of the screen and continuously displays help for keyboard special keys and navigation keys.</p>

5.4.1.2 Entering BIOS Setup

To enter the BIOS Setup using a keyboard (or emulated keyboard), press the <F2> function key during boot time when the OEM or Intel logo is displayed. The following message is displayed on the diagnostics screen and under the Quiet Boot logo screen:

Press <F2> to enter setup

When the Setup Utility is entered, the Main screen is displayed. However, serious errors cause the system to display the Error Manager screen instead of the Main screen.

It is also possible to cause a boot to Setup using an IPMI 2.0 command “Get/Set System Boot Options”. For details on that capability, see the explanation in the IPMI description.

5.4.1.3 Setup Navigation Keyboard Commands

The bottom right portion of the Setup screen provides a list of commands that are used to navigate through the Setup utility. These commands are displayed at all times.

Each Setup menu page contains a number of features. Each feature is associated with a value field, except those used for informative purposes. Each value field contains configurable parameters. Depending on the security option chosen and in effect by the password, a menu feature’s value may or may not be changed. If a value cannot be changed, its field is made inaccessible and appears grayed out.

Table 25. BIOS Setup: Keyboard Command Bar

Key	Option	Description
<Enter>	Execute Command	The <Enter> key is used to activate submenus when the selected feature is a submenu, or to display a pick list if a selected option has a value field, or to select a subfield for multi-valued features like time and date. If a pick list is displayed, the <Enter> key selects the currently highlighted item, undoes the pick list, and returns the focus to the parent menu.
<Esc>	Exit	The <Esc> key provides a mechanism for backing out of any field. When the <Esc> key is pressed while editing any field or selecting features of a menu, the parent menu is re-entered. When the <Esc> key is pressed in any submenu, the parent menu is re-entered. When the <Esc> key is pressed in any major menu, the exit confirmation window is displayed and the user is asked whether changes can be discarded. If “No” is selected and the <Enter> key is pressed, or if the <Esc> key is pressed, the user is returned to where they were before <Esc> was pressed, without affecting any existing settings. If “Yes” is selected and the <Enter> key is pressed, the setup is exited and the BIOS returns to the main System Options Menu screen.
↑	Select Item	The up arrow is used to select the previous value in a pick list, or the previous option in a menu item's option list. The selected item must then be activated by pressing the <Enter> key.
↓	Select Item	The down arrow is used to select the next value in a menu item's option list, or a value field's pick list. The selected item must then be activated by pressing the <Enter> key.
← →	Select Menu	The left and right arrow keys are used to move between the major menu pages. The keys have no effect if a sub-menu or pick list is displayed.
<Tab>	Select Field	The <Tab> key is used to move between fields. For example, <Tab> can be used to move from hours to minutes in the time item in the main menu.
-	Change Value	The minus key on the keypad is used to change the value of the current item to the previous value. This key scrolls through the values in the associated pick list without displaying the full list.
+	Change Value	The plus key on the keypad is used to change the value of the current menu item to the next value. This key scrolls through the values in the associated pick list without displaying the full list. On 106-key Japanese keyboards, the plus key has a different scan code than the plus key on the other keyboards, but will have the same effect.
<F9>	Setup Defaults	Pressing the <F9> key causes the following to display: <div style="border: 1px solid black; padding: 10px; text-align: center;"> Load Optimized Defaults? Yes No </div> If “Yes” is highlighted and <Enter> is pressed, all Setup fields are set to their default values. If “No” is highlighted and <Enter> is pressed, or if the <Esc> key is pressed, the user is returned to where they were before <F9> was pressed without affecting any existing field values.
<F10>	Save and Exit	Pressing the <F10> key causes the following message to display: <div style="border: 1px solid black; padding: 10px; text-align: center;"> Save configuration and reset? Yes No </div> If “Yes” is highlighted and <Enter> is pressed, all changes are saved and the Setup is exited. If “No” is highlighted and <Enter> is pressed, or the <Esc> key is pressed, the user is returned to where they were before <F10> was pressed without affecting any existing values.

5.4.1.4 Setup Screen Menu Selection Bar

The Setup Screen Menu selection bar is located at the top of the BIOS Setup Utility screen. It displays tabs showing the major screen selections available to the user. By using the left and right arrow keys, the user can select the listed screens. Some screen selections are out of the visible menu space, and become available by scrolling to the left or right of the current selections displayed.

5.4.2 BIOS Setup Utility Screens

The following sections describe the screens available in the BIOS Setup utility for the configuration of the server platform.

For each of these screens, there is an image of the screen with a list of Field Descriptions which describe the contents of each item on the screen. Each item on the screen is hyperlinked to the relevant Field Description. Each Field Description is hyperlinked back to the screen image.

These lists follow the following guidelines:

- The text heading for each Field Description is the actual text as displayed on the BIOS Setup screen. This screen text is a hyperlink to its corresponding Field Description.
- The text shown in the Option Values and Help Text entries in each Field Description are the actual text and values are displayed on the BIOS Setup screens.
- In the Option Values entries, the text for default values is shown with an underline. These values do not appear underline on the BIOS Setup screen. The underlined text in this document is to serve as a reference to which value is the default value.
- The Help Text entry is the actual text which appears on the screen to accompany the item when the item is the one in focus (active on the screen).
- The Comments entry provides additional information where it may be helpful. This information does not appear on the BIOS Setup screens.
- Information enclosed in angular brackets (< >) in the screen shots identifies text that can vary, depending on the option(s) installed. For example, <Amount of memory installed> is replaced by the actual value for "Total Memory".
- Information enclosed in square brackets ([]) in the tables identifies areas where the user must type in text instead of selecting from a provided option.
- Whenever information is changed (except Date and Time), the systems requires a save and reboot to take place in order for the changes to take effect. Alternatively, pressing <ESC> discards the changes and resumes POST to continue to boot the system according to the boot order set from the last boot.

5.4.2.1 Map of Screens and Functionality

There are a number of screens in the entire Setup collection. They are organized into major categories. Each category has a hierarchy beginning with a top-level screen from which lower-level screens may be selected. Each top-level screen appears as a tab, arranged across the top of the Setup screen image of all top-level screens.

There are more categories than will fit across the top of the screen, so at any given time there will be some categories which will not appear until the user has scrolled across the tabs which are present.

The categories and the screens included in each category are listed below, with links to each of the screens named.

Table 26. Screen Map

Categories (Top Tabs)	Second Level Screens	Third Level Screens
Main Screen (Tab)		
Advanced Screen (Tab)		
↗	Processor Configuration	
↗	Power and Performance	
↗	Memory Configuration	
	↗	Memory RAS and Performance Configuration
↗	Mass Storage Controller Configuration	
↗	PCI Configuration	
	↗	NIC Configuration
↗	Serial Port Configuration	
↗	USB Configuration	
↗	System Acoustic and Performance Configuration	
Security Screen (Tab)		
Server Management Screen (Tab)		
↗	Console Redirection	
↗	System Information	
↗	BMC LAN Configuration	
Boot Options Screen (Tab)		
↗	CDROM Order	
↗	Hard Disk Order	
↗	Floppy Order	
↗	Network Device Order	
↗	BEV Device Order	

Categories (Top Tabs)	Second Level Screens	Third Level Screens
↵	Add EFI Boot Option	
↵	Delete EFI Boot Option	
Boot Manager Screen (Tab)		
Error Manager Screen (Tab)		
Exit Screen (Tab)		

5.4.2.2 Main Screen (Tab)

The Main Screen is the first screen that appears when the BIOS Setup configuration utility is entered, unless an error has occurred. If an error has occurred, the Error Manager Screen appears instead.

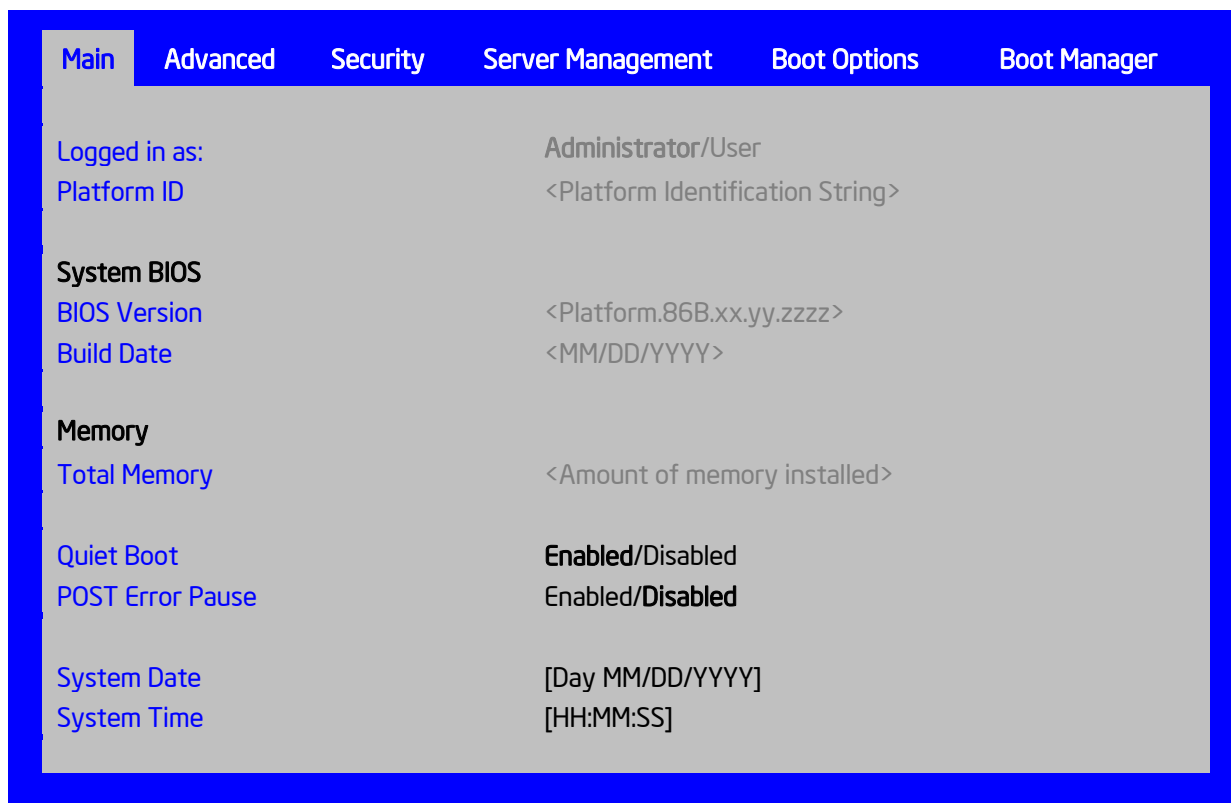

Figure 23. Main Screen

Table 27. Setup Utility – Main Screen Fields

Setup Item	Options	Help Text	Comments
Logged in as			Information only. Displays password level that setup is running in: Administrator or User. With no passwords set, Administrator is the default mode.
Platform ID			Information only. Displays the Platform ID: S2600JF
System BIOS			
Version			Information only. Displays the current BIOS version. xx = major release version yy = minor release version zzzz = release number
Build Date			Information only. Displays the current BIOS build date.

Setup Item	Options	Help Text	Comments
Memory			
Total Memory			Information only. Displays the total physical memory installed in the system, in MB or GB. The term physical memory indicates the total memory discovered in the form of installed DDR3 DIMMs.
Quiet Boot	Enabled Disabled	[Enabled] – Display the logo screen during POST. [Disabled] – Display the diagnostic screen during POST.	
POST Error Pause	Enabled Disabled	[Enabled] – Go to the Error Manager for critical POST errors. [Disabled] – Attempt to boot and do not go to the Error Manager for critical POST errors.	If enabled, the POST Error Pause option takes the system to the error manager to review the errors when major errors occur. Minor and fatal error displays are not affected by this setting.
System Date	[Day of week MM/DD/YYYY]	System Date has configurable fields for Month, Day, and Year. Use [Enter] or [Tab] key to select the next field. Use [+] or [-] key to modify the selected field.	
System Time	[HH:MM:SS]	System Time has configurable fields for Hours, Minutes, and Seconds. Hours are in 24-hour format. Use [Enter] or [Tab] key to select the next field. Use [+] or [-] key to modify the selected field.	

5.4.2.3 Advanced Screen (Tab)

The Advanced screen provides an access point to configure several groups of options. On this screen, the user can select the option group to be configured. Configuration actions are performed on the selected screen, and not directly on the Advanced screen.

To access this screen from the **Main** screen or other top-level “Tab” screen, press the right or left arrow keys to traverse the tabs at the top of the Setup screen until the **Advanced** screen is selected.

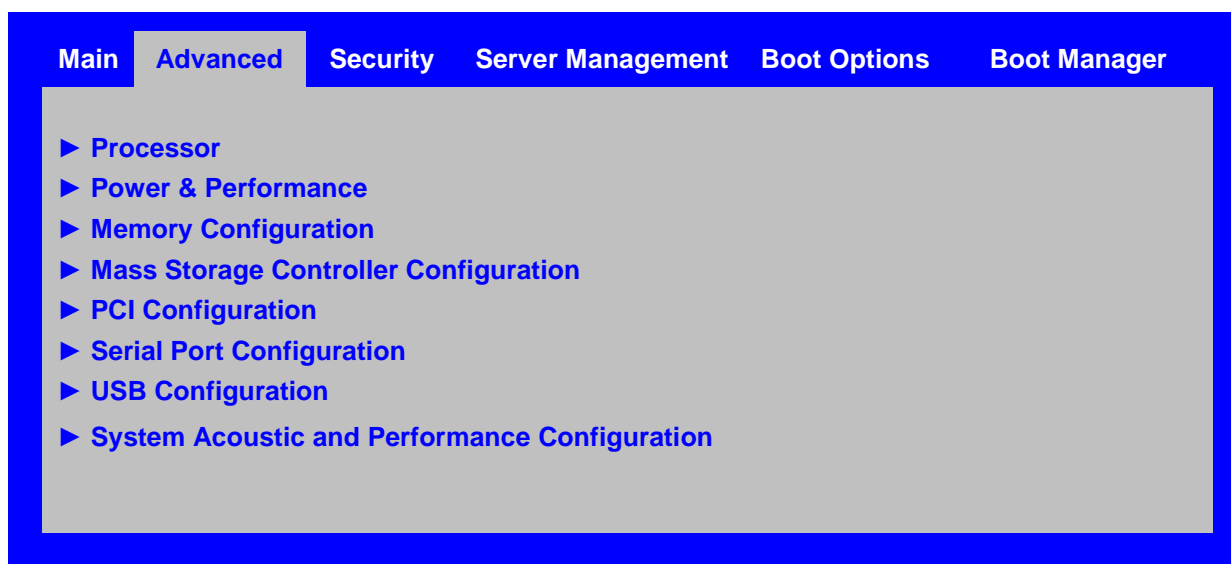

Figure 24. Advanced Screen

Table 28. Setup Utility – Advanced Screen Display Fields

Setup Item	Help Text
Processor Configuration	View/Configure processor information and settings.
Power and Performance	View/Configure power and performance policy
Memory Configuration	View/Configure memory information and settings.
Mass Storage Controller Configuration	View/Configure mass storage controller information and settings.
PCI Configuration	View/Configure PCI information and settings.
Serial Port Configuration	View/Configure serial port information and settings.
USB Configuration	View/Configure USB information and settings.
System Acoustic and Performance Configuration	View/Configure system acoustic and performance information and settings.

5.4.2.4 Processor Configuration

The Processor Configuration screen displays the processor identification and microcode level, core frequency, cache sizes, Intel® QuickPath Interconnect information for all processors currently installed. It also allows the user to enable or disable a number of processor options.

To access this screen from the **Main** screen, select **Advanced > Processor Configuration**. To move to another screen, press the **<Esc>** key to return to the **Advanced screen**, then select the desired screen.

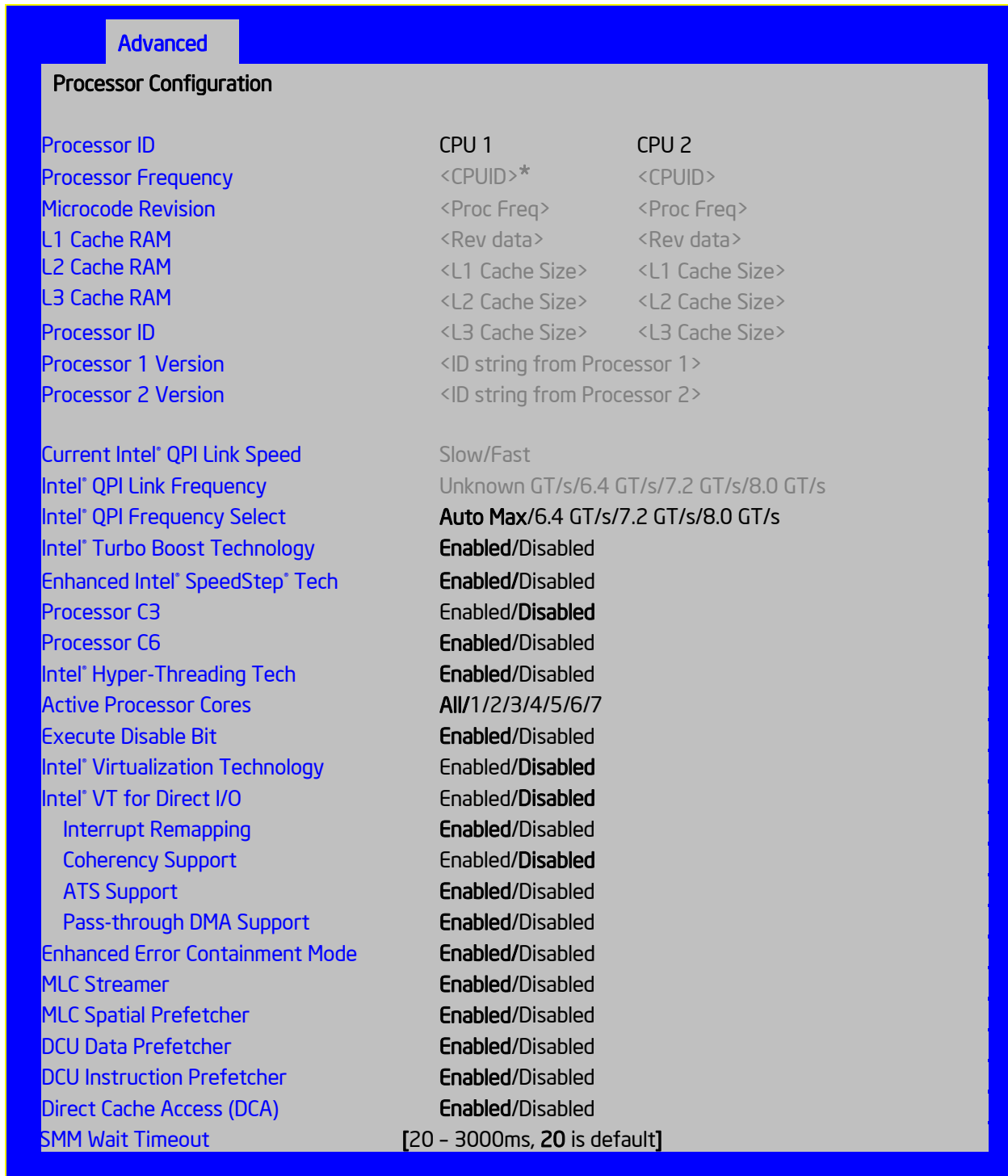

Figure 25. Processor Configuration Screen

Table 29. Setup Utility — Processor Configuration Screen Fields

Setup Item	Options	Help Text	Comments
Processor ID			Information only. Processor CPUID
Processor Frequency			Information only. Current frequency of the processor.
Microcode Revision			Information only. Revision of the loaded microcode.
L1 Cache RAM			Information only. Size of the Processor L1 Cache.
L2 Cache RAM			Information only. Size of the Processor L2 Cache
L3 Cache RAM			Information only. Size of the Processor L3 Cache.
Processor Version			Information only. ID string from the Processor.
Processor 1 Version			Information only. Brand ID string of processor with CPUID instruction.
Processor 2 Version			Information only. Brand ID string of processor with CPUID instruction.
Current QPI Link Speed			Information only. Current speed that the QPI Link is using.
QPI Link Frequency			Information only. Current frequency that the QPI Link is operating.
Current QPI Frequency Select	Auto Max 6.4 GT/s 7.2 GT/s 8.0 GT/s	Allows for selecting the Intel® QuickPath Interconnect Frequency. Recommended to leave in [Auto Max] so that BIOS can select the highest common Intel® QuickPath Interconnect frequency.	Lowering the QPI frequency may improve performance per watt for some processing loads and on certain benchmarks. [Auto Max] will give the maximum QPI performance available. <i>Appears only on multi-socket boards.</i> When a multi-socket board has only one processor installed, this will be grayed out, with the previous value remaining displayed. Changes in QPI Link Frequency will not take effect until the system reboots, so this will not immediately change the QPI Link Frequency display. Changing QPI Link Frequency does not affect the QPI Link Speed.

Setup Item	Options	Help Text	Comments
Intel® Turbo Boost Technology	Enabled Disabled	Intel® Turbo Boost Technology allows the processor to automatically increase its frequency if it is running below power, temperature, and current specifications.	This option is only visible if the processor in the system support Intel® Turbo Boost Technology.
Enhanced Intel® SpeedStep Technology	Enabled Disabled	Enhanced Intel® SpeedStep Technology allows the system to dynamically adjust processor voltage and core frequency, which can result in decreased average power consumption and decreased average heat production. Contact your OS vendor regarding OS support of this feature.	When Disabled, the processor setting reverts to running at Max TDP Core Frequency (rated frequency).
Processor C3	Enabled Disabled	Enable/Disable Processor C3 (ACPI C2/C3) report to OS	This is normally Disabled , but can be Enabled for improved performance on certain benchmarks and in certain situations.
Processor C6	Enabled Disabled	Enable/Disable Processor C6 (ACPI C3) report to OS	This is normally Enabled but can be Disabled for improved performance on certain benchmarks and in certain situations.
Intel® Hyper-Threading Technology	Enabled Disabled	Intel® HT Technology allows multithreaded software applications to execute threads in parallel within each processor. Contact your OS vendor regarding OS support of this feature.	This option is only visible if all processors installed in the system support Intel® Hyper-Threading Technology.
Active Processor Cores	All 1 2 3 4 5 6 7	Number of cores to enable in each processor package.	The numbers of cores that appear as selections depends on the number of cores available in the processors installed. Boards may have as many as eight cores in each of 1, 2, or 4 processors. The same number of cores must be active in each processor package.
Execute Disable Bit	Enabled Disabled	Execute Disable Bit can help prevent certain classes of malicious buffer overflow attacks.	This option is only visible if all processors installed in the system support the Execute Disable Bit. The OS and applications installed must support this feature in order for it to be enabled.
Intel® Virtualization Technology	Enabled Disabled	Intel® Virtualization Technology allows a platform to run multiple operating systems and applications in independent partitions. Note: A change to this option requires the system to be powered off and then back on before the setting takes effect.	This option is only visible if all processors installed in the system support Intel® VT. The software configuration installed on the system must support this feature in order for it to be enabled.

Setup Item	Options	Help Text	Comments
Intel® Virtualization Technology for Directed I/O	Enabled Disabled	Enable/Disable Intel® Virtualization Technology for Directed I/O. (Intel® VT-d) Report the I/O device assignment to VMM through DMAR ACPI Tables	This option is only visible if all processors installed in the system support Intel® VT-d. The software configuration installed on the system must support this feature in order for it to be enabled.
Interrupt Remapping	Enabled Disabled	Enable/Disable Intel® VT-d Interrupt Remapping support. For some processors, this option may be "always enabled".	This option only appears when Intel® Virtualization Technology for Directed I/O is Enabled. For some processors this will be enabled unconditionally whenever Intel® VT-d is enabled. In that case, this option will be shown as "Enabled", and grayed out and not changeable.
Coherency Support	Enabled Disabled	Enable/Disable Intel® VT-d Coherency support.	This option only appears when Intel® Virtualization Technology for Directed I/O is Enabled .
ATS Support	Enabled Disabled	Enable/Disable Intel® VT-d Address Translation Services (ATS) support.	This option only appears when Intel® Virtualization Technology for Directed I/O is Enabled .
Pass-through DMA Support	Enabled Disabled	Enable/Disable Intel® VT-d Pass-through DMA support. For some processors, this option may be "always enabled".	This option only appears when Intel® Virtualization Technology for Directed I/O is Enabled . For some processors this will be enabled unconditionally whenever Intel® VT-d is enabled. In that case, this option will be shown as "Enabled", and grayed out and not changeable.
Enhanced Error Containment Mode	Enabled Disabled		Enhanced Error Containment (Data Poisoning) is not supported by all models of processors, and this option will not appear unless all installed processors support Enhanced Error Containment. This option globally enables or disables both Core and Uncore Data Poisoning, for processors which support them
MLC Streamer	Enabled Disabled	MLC Streamer is a speculative prefetch unit within the processor(s)	MLC Streamer is normally Enabled , for best efficiency in L2 Cache and Memory Channel use, but disabling it may improve performance for some processing loads and on certain benchmarks.

Setup Item	Options	Help Text	Comments
MLC Spatial Prefetcher	Enabled Disabled	[Enabled] – Fetches adjacent cache line (128 bytes) when required data is not currently in cache. [Disabled] – Only fetches cache line with data required by the processor (64 bytes).	MLC Spatial Prefetcher is normally Enabled , for best efficiency in L2 Cache and Memory Channel use, but disabling it may improve performance for some processing loads and on certain benchmarks.
DCU Data Prefetcher	Enabled Disabled	The next cache line will be prefetched into L1 data cache from L2 or system memory during unused cycles if it sees that the processor core has accessed several bytes sequentially in a cache line as data. [Disabled] – Only fetches cache line with data required by the processor (64 bytes).	DCU Data Prefetcher is normally Enabled , for best efficiency in L1 Data Cache and Memory Channel use, but disabling it may improve performance for some processing loads and on certain benchmarks.
DCU Instruction Prefetcher	Enabled Disabled	The next cache line will be prefetched into L1 instruction cache from L2 or system memory during unused cycles if it sees that the processor core has accessed several bytes sequentially in a cache line as data.	DCU Data Prefetcher is normally Enabled , for best efficiency in L1 I Cache and Memory Channel use, but disabling it may improve performance for some processing loads and on certain benchmarks.
Direct Cache Access (DCA)	Enabled Disabled	Allows processors to increase the I/O performance by placing data from I/O devices directly into the processor cache.	System performance is usually best with Direct Cache Access Enabled. In certain unusual cases, disabling this may give improved results.
SMM Wait Timeout	20	Millisecond timeout waiting for BSP and SPs to enter SMM. Range is 20ms to 3000ms	Amount of time to allow for the SMI Handler to respond to an SMI. If exceeded, BMC generates an SMI Timeout and resets the system

5.4.2.5 Power and Performance policy

The Power and Performance screen allows the user to specify a profile which is optimized in the direction of either reduced power consumption or increased performance.

To access this screen from the **Main** screen, select **Advanced > Power and Performance**. To move to another screen, press the <Esc> key to return to the **Advanced** screen, then select the desired screen.

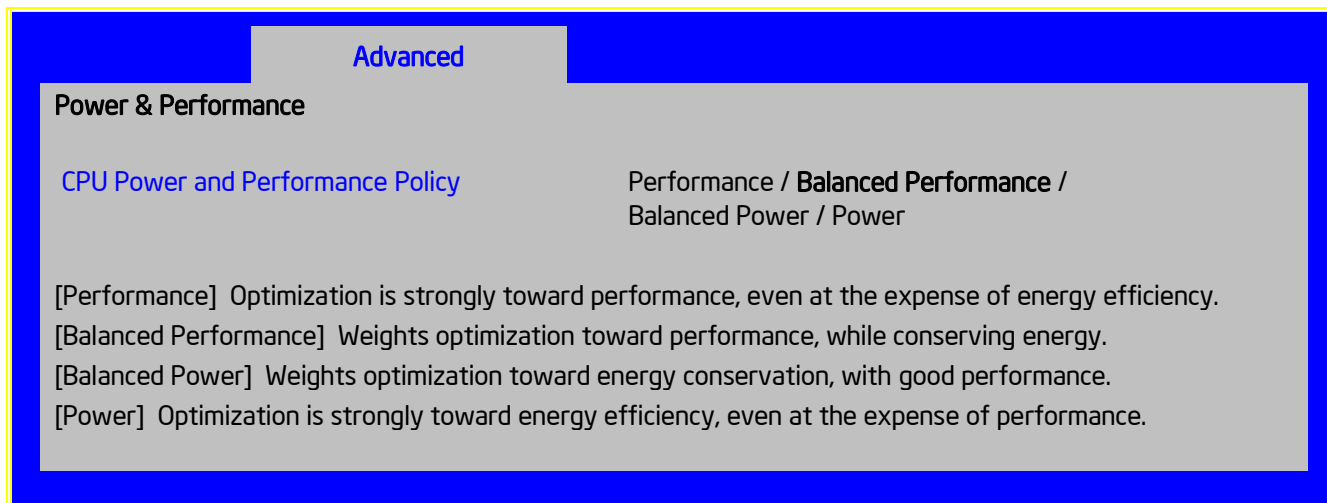

Figure 26. Power and Performance Configuration Screen

Table 30. Setup Utility – Power and Performance Configuration Screen Fields

Setup Item	Options	Comments
CPU Power and Performance Policy	Performance	Optimization is strongly toward performance, even at the expense of energy efficiency.
	Balanced Performance	Weights optimization toward performance, while conserving energy.
	Balanced Power	Weights optimization toward energy conservation, with good performance
	Power	Optimization is strongly toward energy efficiency, even at the expense of performance.

When the user selects a “Power and Performance Policy” in Setup , there is a list of complementary settings which are made. These can be individually overridden after the policy setting has been selected and the profile settings performed. The profile settings are listed in the following table.

Table 31. Power/Performance Profiles

BIOS Features	Available Settings	Performance	Balanced Performance	Balanced Power	Power
Setup: Advanced > Power and Performance					
CPU Power and Performance Policy	Performance / Balanced Performance /Balanced Power /Power	Performance	(Balanced Performance)	Balanced Power	Power
Setup: Advanced > Processor Configuration					
Intel® QPI Frequency Select	Auto Max /6.4 GT/s /7.2 GT/s /8.0 GT/s	(Auto Max)	(Auto Max)	(Auto Max)	6.4 GT/s
Intel® Turbo Boost Technology	Enabled/Disabled	(Enabled)	(Enabled)	(Enabled)	(Enabled)

BIOS Features	Available Settings	Performance	Balanced Performance	Balanced Power	Power
Enhanced Intel® SpeedStep® Technology	Enabled/Disabled	(Enabled)	(Enabled)	(Enabled)	(Enabled)
Processor C3	Enabled/Disabled	(Disabled)	(Disabled)	(Disabled)	(Disabled)
Processor C6	Enabled/Disabled	(Enabled)	(Enabled)	(Enabled)	(Enabled)
Intel® Hyper Threading	Enabled/Disabled	(Enabled)	(Enabled)	(Enabled)	(Enabled)
Active Processor Cores	All/1/2/3/4/5/6/7	(All)	(All)	(All)	(All)
MLC Streamer	Enabled/Disabled	(Enabled)	(Enabled)	(Enabled)	(Enabled)
MLC Spatial Prefetcher	Enabled/Disabled	(Enabled)	(Enabled)	(Enabled)	(Enabled)
DCU Data Prefetcher	Enabled/Disabled	(Enabled)	(Enabled)	(Enabled)	(Enabled)
DCU Instruction Prefetcher	Enabled/Disabled	(Enabled)	(Enabled)	(Enabled)	(Enabled)
Direct Cache Access (DCA)	Enabled/Disabled	(Enabled)	(Enabled)	(Enabled)	(Enabled)
Setup: Advanced > Memory Configuration					
Memory Operating Speed Selection	Auto/800/1067/1333/1600	(Auto)	(Auto)	(Auto)	(Auto)
Patrol Scrub	Enabled/Disabled	(Enabled)	(Enabled)	(Enabled)	(Enabled)
Demand Scrub	Enabled/Disabled	(Enabled)	(Enabled)	(Enabled)	(Enabled)
Memory Power Optimization	Power Optimized/ Performance Optimized	(Performance Optimized)	(Performance Optimized)	(Performance Optimized)	(Performance Optimized)
Setup: Advanced > Memory Configuration > Memory RAS and Performance Configuration					
NUMA Optimized	Enabled/Disabled	(Enabled)	(Enabled)	(Enabled)	(Enabled)
Setup: Advanced > System Acoustic and Performance Configuration					
Set Throttling Mode	Auto/DCLTT/SCLTT/SOLTT	(Auto)	(Auto)	(Auto)	(Auto)
Set Fan Profile	Performance/Acoustic	(Performance)	(Performance)	(Performance)	(Performance)
Quiet Fan Idle Mode	Enabled/Disabled	(Disabled)	(Disabled)	(Disabled)	(Disabled)
Setup: Server Management					
EuP LOT6 OFF-Mode	Enabled/Disabled	(Disabled)	(Disabled)	(Disabled)	(Disabled)
Internal BIOS Settings not displayed in BIOS Setup					
QPI Link LOS enable	Auto/Enabled/Disabled	Disabled	(Auto)	(Auto)	(Auto)
CKE Throttling	Auto/Enabled/Disabled	Disabled	(Auto)	(Auto)	Enabled
Memory Voltage	Auto/1.5V/1.35V	1.5v	(Auto)	(Auto)	(Auto)
CPU PkgC State Limit	Disabled/C6 with no retention/ C6 with retention	Disabled	(C6 with retention)	(C6 with retention)	(C6 with retention)
Processor C1 mapped to ACPI C1	Enabled/Disabled	(Enabled)	(Enabled)	(Enabled)	(Enabled)
Processor C6 with retention mapped to ACPI C2	Enabled/Disabled	(Enabled)	(Enabled)	(Enabled)	(Enabled)
ACPI C3	Enabled/Disabled	(Disabled)	(Disabled)	(Disabled)	(Disabled)
Processor C1/C3 Auto Demotion	Enabled/Disabled	(Enabled)	(Enabled)	(Enabled)	(Enabled)
Processor C1/C3 UnDemotion	Enabled/Disabled	(Enabled)	(Enabled)	(Enabled)	(Enabled)

BIOS Features	Available Settings	Performance	Balanced Performance	Balanced Power	Power
ENERGY_PERF_BIAS mode	Performance/ Balanced Performance /Balanced Power/Power	Performance	(Balanced Performance)	Balanced Power	Power

5.4.2.6 Memory Configuration

The Memory Configuration screen allows the user to view details about the DDR3 DIMMs that are installed as system memory.

To access this screen from the **Main** screen, select **Advanced > Memory Configuration**. To move to another screen, press the <Esc> key to return to the **Advanced** screen, then select the desired screen.



Figure 27. Memory Configuration Screen

Table 32. Setup Utility – Memory Configuration Screen Fields

Setup Item	Options	Comments
Total Memory		Information only. The amount of memory available in the system in the form of installed DDR3 DIMMs in units of GB.
Effective Memory		Information only. The amount of memory available to the operating system in MB or GB. The Effective Memory is the difference between the Total Physical Memory and the sum of all memory reserved for internal usage, RAS redundancy and SMRAM. This difference includes the sum of all DDR3 DIMMs that failed Memory BIST during POST, or were disabled by the BIOS during memory discovery phase to optimize memory configuration.
Current Configuration	Independent Channel Mirror Lockstep	Displays one of the following: Independent Channel – DIMMs are operating in Independent Channel Mode, the default configuration when there is no RAS Mode configured. Mirror – Mirroring RAS Mode has been configured and is operational. Lockstep – Lockstep RAS Mode has been configured and is operational
Current Memory Speed		Information only. Displays the speed the memory is running at.
Memory Operating Speed Selection	Auto 800 1066 1333 1600	Allows the user to select a specific speed at which memory will operate. Only speeds that are legitimate are available, that is, the user can only specify speeds less than or equal to the auto-selected Memory Operating Speed. The default Auto setting will select the highest achievable Memory Operating Speed consistent with the DIMMs and processors installed.
Patrol Scrub	Enabled Disabled	When enabled, Patrol Scrub is initialized to read through all of memory in a 24-hour period, correcting any Correctable ECC Errors it encounters by writing back the corrected data to memory.
Demand Scrub	Enabled Disabled	When enabled, Demand Scrub automatically corrects a Correctable ECC Error encountered during a fetch from memory by writing back the corrected data to memory.
Correctable Error Threshold	20 10 5 All None	Specifies how many Correctable Errors must occur before triggering the logging of a SEL Correctable Error Event. Only the first threshold crossing is logged, unless “All” is selected. “All” causes every CE that occurs to be logged. “None” suppresses CE logging completely.
Memory Power Optimized	Performance Optimized Power Optimized	

Setup Item	Options	Comments
DIMM_XY		<p>Displays the state of each DIMM socket present on the board. Each DIMM socket field reflects one of the following possible states:</p> <p>Operational – There is a DDR3 DIMM installed and operational in this slot.</p> <p>Not Installed – There is no DDR3 DIMM installed in this slot.</p> <p>Failed – The DIMM installed in this slot has failed during initialization.</p> <p>Disabled – The DIMM installed in this slot was disabled during initialization.</p> <p>For each DIMM that is in an Operational status, the size in GB of that DIMM is displayed.</p> <p>Note: X denotes the Channel Identifier and Y denote the DIMM Identifier within the Channel.</p>

5.4.2.7 Memory RAS and Performance Configuration

The Memory RAS and Performance Configuration screen allows the user to customize several memory configuration options, such as whether to use Memory Mirroring or Memory Sparring.

To access this screen from the **Main** screen, select **Advanced > Memory Configuration > Memory RAS and Performance Configuration**. To move to another screen, press the <Esc> key to return to the **Memory Configuration** screen, if necessary press the <Esc> key again to return to the **Advanced** screen, then select the desired screen.

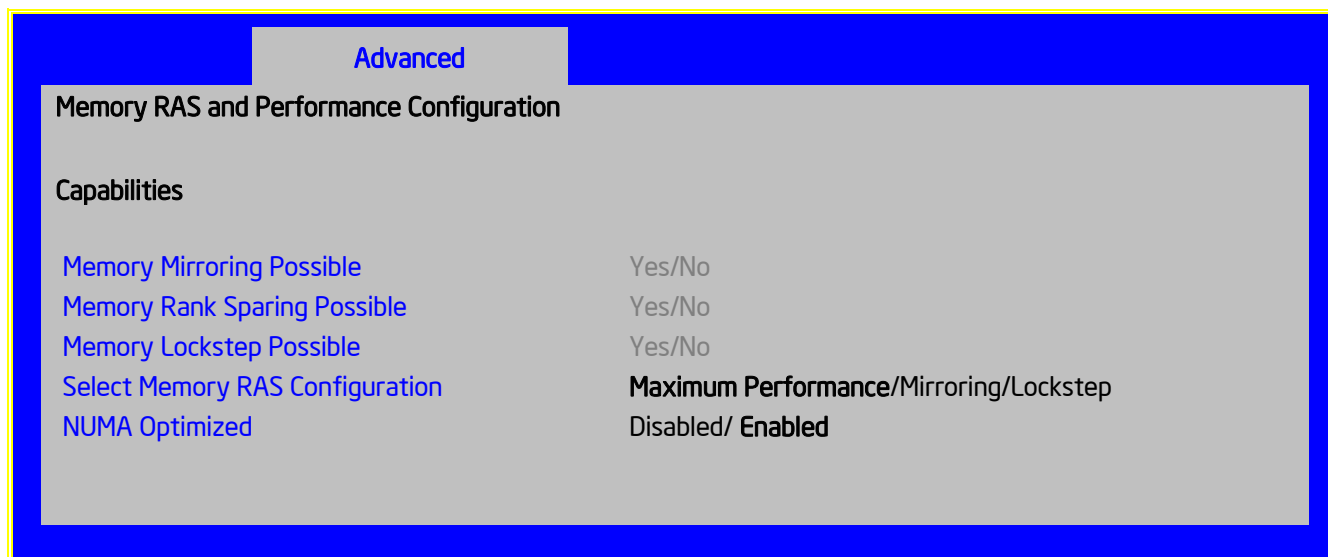

Figure 28. Memory RAS and Performance Configuration Screen

Table 33. Setup Utility – Memory RAS and Performance Configuration Fields

Setup Item	Options	Help Text	Comments
Memory Mirroring Possible	Yes No		<i>Information only.</i> Displays whether the current DIMM configuration is capable of Memory Mirroring.

Setup Item	Options	Help Text	Comments
Memory Rank Sparing Possible	Yes No		<i>Information only.</i> Displays whether the current DIMM configuration is capable of Rank Sparing.
Memory Lockstep Possible	Yes No		<i>Information only.</i> Displays whether the current DIMM configuration is capable of Memory Lockstep.
Select Memory RAS Configuration	Maximum Performance Mirroring Lockstep	<i>Allows the user to select the memory RAS Configuration to be applied for the next boot.</i>	Available modes depend on the current memory population. Modes which are not listed as “possible” should not be available as choices. If the only valid choice is “Maximum Performance”, then this option should be grayed out and unavailable.
NUMA Optimized	Enabled Disabled	<i>If enabled, BIOS includes ACPI tables that are required for NUMA-aware Operating Systems.</i>	This option is only present for boards which have two or more processor sockets. When a multi-socket board has only a single processor installed, this option is grayed out and set as Disabled.

5.4.2.8 Mass Storage Controller Configuration

The Mass Storage Configuration screen allows the user to configure the Mass Storage controllers that are integrated into the server board on which the BIOS is executing.

To access this screen from the **Main** screen, select **Advanced > Mass Storage Controller Configuration**. To move to another screen, press the <Esc> key to return to the **Advanced** screen, then select the desired screen.

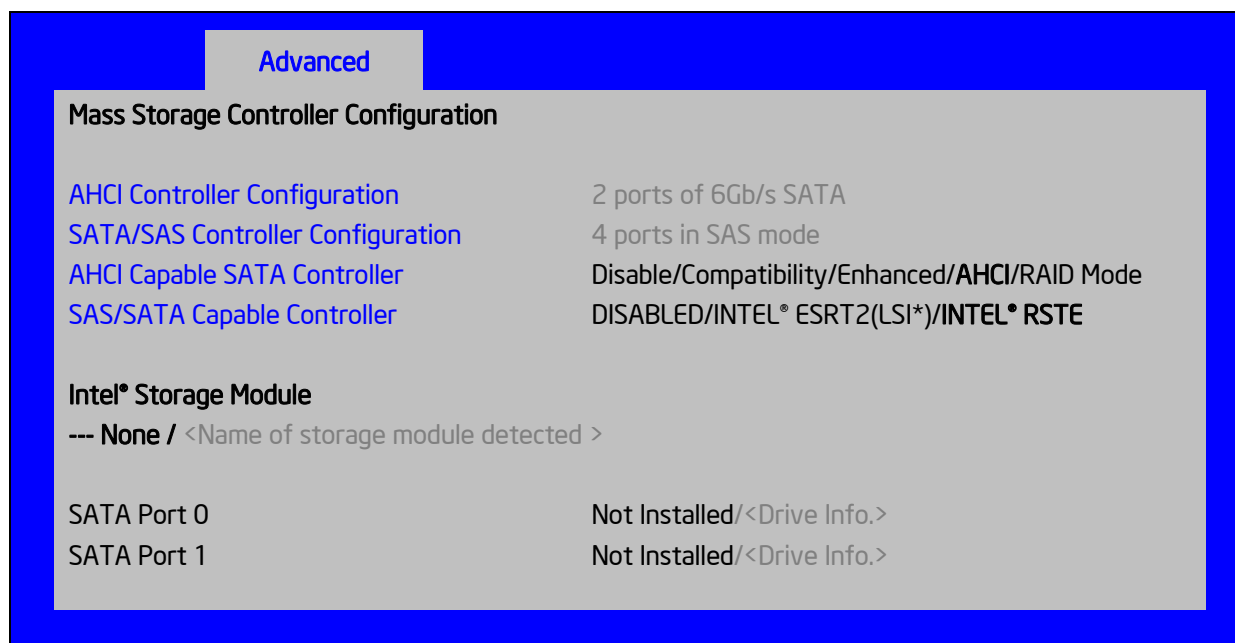

Figure 29. Mass Storage Controller Configuration Screen

Table 34. Setup Utilities – Mass Storage Controller Configuration Fields

Setup Item	Options	Help Text	Comments
AHCI Controller Configuration			Information only
SATA/SAS Controller Configuration			Information only
AHCI Capable SATA Controller	Disabled Compatibility Enhanced AHCI RAID Mode	- Compatibility provides PATA emulation on the SATA device - Enhanced provides Native SATA support - AHCI enables the Advanced Host Controller Interface, which provides Enhanced SATA functionality - RAID Mode provides host based RAID support on the onboard SATA ports	This option configures the onboard AHCI-capable SATA controller, which is distinct from the SCU.
SAS/SATA Capable Controller	Disabled Intel® ESRT2 (LSI*) Intel® RSTe	- Intel® ESRT2: Provides host based RAID 0/1/10 and optional RAID 5. Uses Intel® ESRT2 drivers (based on LSI* MegaSR). - Intel® RSTe: Provides pass-through drive support. Also provides host based RAID 0/1/10 support, and RAID 5 (in SATA mode only). Uses Intel® RSTe iastor drivers.	This option selects the RAID stack to be used with the SCU. If <i>Disabled</i> is selected, any drives connected to the SCU will not be usable.
Intel® Storage Module	--- None		Information Only

Setup Item	Options	Help Text	Comments
SATA Port x	Not Installed Drive Info	Ports 0-1: 6Gb SATA capable port	<i>Information only.</i> This is repeated for all 6 SATA Port for the Onboard SATA Controller. This section for SATA Drive Information does not appear when the SATA Mode is <u>RAID Mode</u> .

5.4.2.9 PCI Configuration

The PCI Configuration screen allows the user to configure the PCI memory space used for onboard and add-in adapters, configure video options, and configure onboard adapter options. It also displays the NIC MAC Addresses currently in use.

To access this screen from the **Main** screen, select **Advanced > PCI Configuration**. To move to another screen, press the <Esc> key to return to the **Advanced** screen, then select the desired screen.

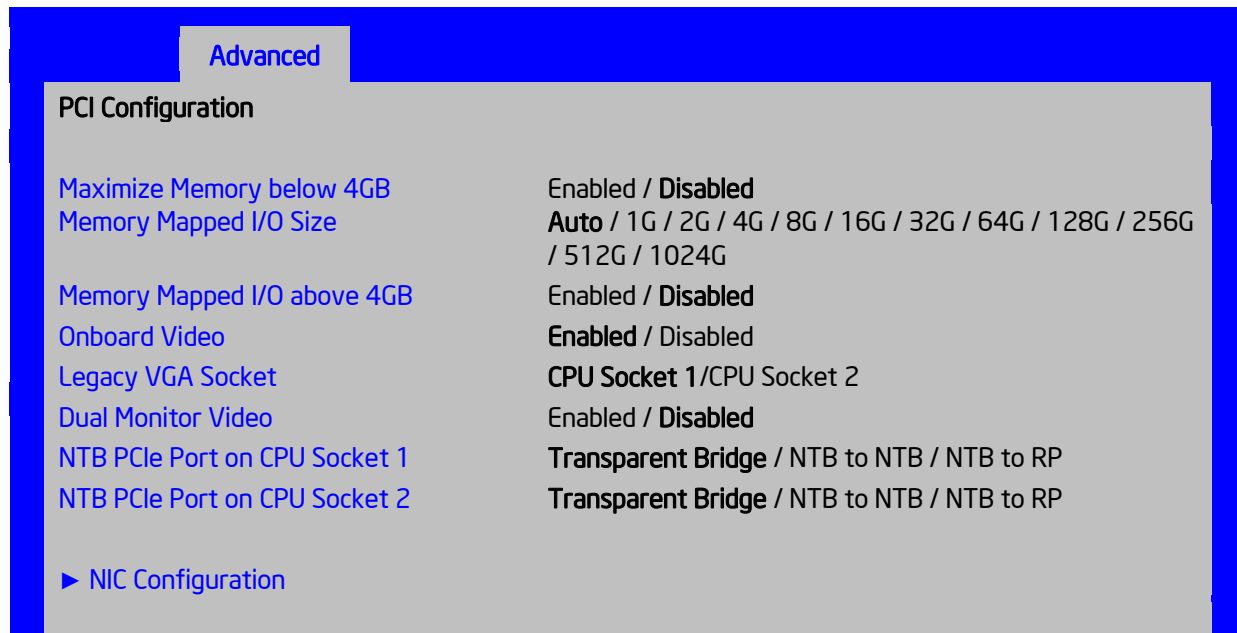

Figure 30. PCI Configuration Screen

Table 35. Setup Utility – PCI Configuration Screen Fields

Setup Item	Options	Help Text	Comments
Maximize Memory below 4GB	Enabled Disabled	<i>BIOS maximizes memory usage below 4GB for an OS without PAE support, depending on the system configuration. Only enable for an OS without PAE support.</i>	When this option is enabled, BIOS makes as much memory available as possible in the 32-bit (4GB) address space, by limiting the amount of PCI/PCIe Memory Address Space and PCIe Extended Configuration Space. This option should only be enabled for a 32-bit OS without PAE capability or without PAE enabled.
Memory Mapped I/O above 4GB	Enabled Disabled	Enable or disable memory mapped I/O of 64-bit PCI devices to 4 GB or greater address space.	When enabled, PCI/PCIe Memory Mapped I/O for devices capable of 64-bit addressing is allocated to address space above 4GB, in order to allow larger allocations and avoid impacting address space below 4GB.
Onboard Video	Enabled Disabled	Onboard video controller. Warning: System video is completely disabled if this option is disabled and an add-in video adapter is not installed.	When disabled, the system requires an add-in video card in order for the video to be seen.
Legacy VGA Socket	CPU Spcket 1 CPU Socket 2	Determines whether Legacy VGA video output is enabled for PCIe slots attached to Processor Socket 1 or 2. Socket 1 is the default.	This option is necessary when using an add-in video card on a PCIe slot attached to CPU Socket 2, due to a limitation of the processor IIO. The Legacy video device can be connected through either socket, but there is a setting that must be set on only one of the two. This option allows the switch to using a video card in a slot connected to CPU Socket 2.
Dual Monitor Video	Enabled Disabled	If enabled. both the onboard video controller and an add-in video adapter are enabled for system video. The onboard video controller becomes the primary video device.	This option must be enabled to use an add-in card as a secondary POST Legacy Video device while also displaying on the Onboard Video device. If there is no add-in video card in any PCIe slot connected to CPU Socket 1, this options is set to <i>Disabled</i> and grayed out and unavailable.

Setup Item	Options	Help Text	Comments
NTB PCIe Port on CPU Socket 1	Transparent Bridge/ NTB to NTB/NTB to RP	Configure CPU PCIe root port 3A as transparent bridge, or NTB to NTB, or NTB to Root Port.	Default is Transparent Bridge.
NTB PCIe Port on CPU Socket 2	Transparent Bridge/ NTB to NTB/NTB to RP	Configure CPU PCIe root port 3A as transparent bridge, or NTB to NTB, or NTB to Root Port.	Default is Transparent Bridge.
NIC Configuration		View/Configure NIC information and settings	

5.4.2.10 NIC Configuration

The NIC Configuration screen allows the user to configure on board NIC port 1 and port 2.



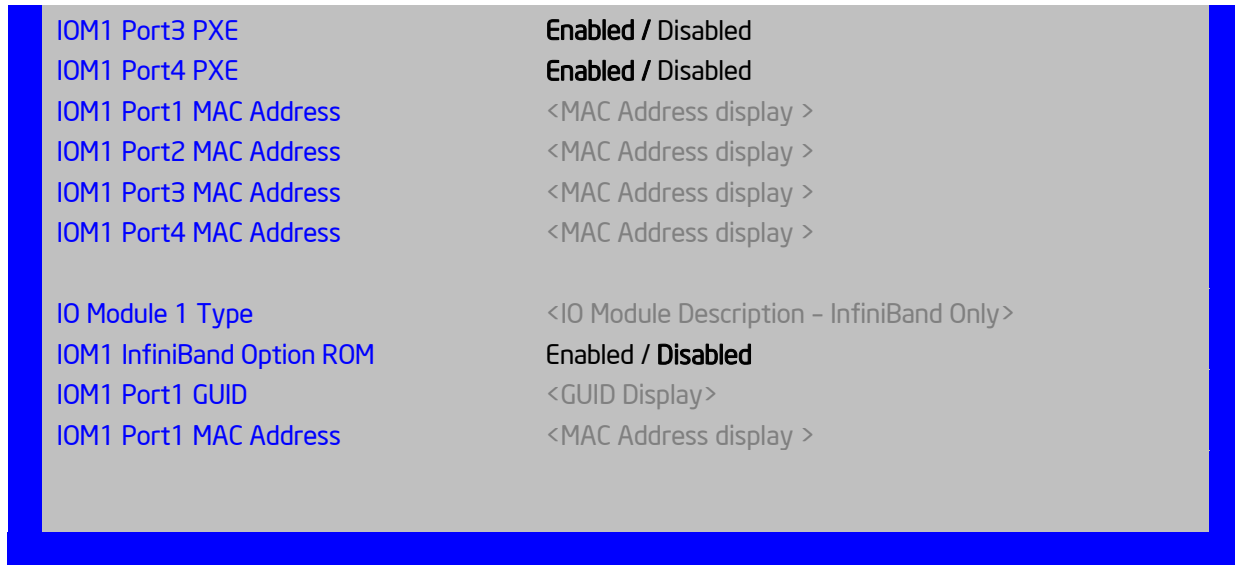

Figure 31. NIC Configuration Screen

Table 36. Setup Utility – NIC Configuration Screen Fields

Setup Item	Options	Help Text	Comments
Wake on LAN (PME)	Enabled Disabled	Enables or disables PCI PME function for Wake on LAN capability from LAN adapters.	Enables/disables PCI/PCIe PME# signal to generate Power Management Events (PME) and ACPI Table entries required for Wake on LAN (WOL). However, note that this will enable WOL only with an ACPI-capable Operating System which has the WOL function enabled.

Setup Item	Options	Help Text	Comments
PXE 1GbE Option ROM	Enabled Disabled	Enable/Disable Onboard/IOM NIC PXE Option ROM Load.	<p>This selection is to enable/disable the 1GbE PXE Option ROM that is used by all Onboard and IO Module 1 GbE controllers.</p> <p>This option is grayed out and not accessible if the discs Option ROM is enabled. It can co-exist with the 10 GbE PXE Option ROM, the 10 GbE FCoE Option ROM, or with an InfiniBand* controller Option ROM.</p> <p>If the 1GbE PXE Option ROM is disabled, and no other Option ROM is enabled, the system cannot perform a Network Boot and cannot respond for Wake-on-LAN.</p> <p>This 1GbE PXE option does not appear unless there is a 1 GbE NIC installed in the system as an Onboard or IO Module NIC.</p>

Setup Item	Options	Help Text	Comments
PXE 10GbE Option ROM	Enabled Disabled	Enable/Disable Onboard/IOM NIC PXE Option ROM Load.	<p>This selection is to enable/disable the 10GbE PXE Option ROM that is used by all Onboard and IO Module 10 GbE controllers.</p> <p>This option is grayed out and not accessible if the discs Option ROM is enabled or the 10 GbE FCoE Option ROM is enabled. It can co-exist with the 1 GbE PXE Option ROM or with an InfiniBand* controller Option ROM.</p> <p>If the 10GbE PXE Option ROM is disabled, and no other Option ROM is enabled, the system cannot perform a Network Boot and cannot respond for Wake-on-LAN.</p> <p>This 10GbE PXE option does not appear unless there is a 10 GbE NIC installed in the system as an Onboard or IO Module NIC.</p>

Setup Item	Options	Help Text	Comments
FCoE 10GbE Option ROM	Enabled Disabled	Enable/Disable Onboard/IOM NIC FCoE Option ROM Load.	<p>This selection is to enable/disable the 10GbE FCoE Option ROM that is used by all Onboard and IO Module 10 GbE controllers capable of FCoE support. At the present time, only the Intel® 82599 10 Gigabit SFP+ NIC supports FCoE for this family of server boards.</p> <p>This option is grayed out and not accessible if the 10GbE PXE Option ROM is enabled or if the discs Option ROM is enabled. It can co-exist with the 1GbE PXE Option ROM or with an InfiniBand* controller Option ROM.</p> <p>If the FCoE Option ROM is disabled, and no other Option ROM is enabled, the system cannot perform a Network Boot and cannot respond for Wake-on-LAN.</p> <p>This FCoE option does not appear unless there is a FCoE-capable 10GbE NIC installed in the system as an Onboard or IO Module NIC.</p>

Setup Item	Options	Help Text	Comments
Discs 1GbE/10GbE Option ROM	Enabled Disabled	Enable/Disable Onboard/IOM NIC discs Option ROM Load.	<p>This selection is to enable/disable the discs Option ROM that is used by all Onboard and IO Module 1 GbE and 10 GbE controllers.</p> <p>This option is grayed out and not accessible if the 1 GbE or 10GbE PXE Option ROM is enabled or if the 10 GbE FCoE Option ROM is enabled. It can co-exist with an InfiniBand* controller Option ROM.</p> <p>If the discs Option ROM is disabled, and no other Option ROM is enabled, the system cannot perform a Network Boot and cannot respond for Wake-on-LAN.</p> <p>This discs option does not appear unless there is an discs-capable NIC installed in the system as an Onboard or IO Module NIC.</p>
Onboard NIC1 Type Onboard NIC2 Type		None Intel® 82574 Single-Port Gigabit Ethernet Controller Intel® I350 Dual-Port Gigabit Ethernet Controller Intel® I350 Quad-Port Gigabit Ethernet Controller Intel® I540 Dual-Port X540 10 Gigabit RJ-45 Controller Mellanox* ConnectX-3* Single-Port InfiniBand* FD14 Controller	Information only
IO Module 1 Type IO Nodule 2 Type		None Intel® I350 Quad-Port Gigabit Ethernet Module Intel® I540 Dual-Port X540 10 Gigabit RJ-45 Module Intel® 82599 Dual-Port 10 Gigabit SFP+ Module Mellanox* ConnectX-3* Single-Port InfiniBand* FD14 Module	Information only

Setup Item	Options	Help Text	Comments
NIC1 Controller NIC2 Controller	Enable Disable	Enable/Disable Onboard Network Controller	<p>This will completely disable Onboard Network Controller NIC1 or NIC2, along with all included NIC Ports and their associated options. That controller's NIC Ports, Port PXE options, and Port MAC Address displays will not appear.</p> <p>This option only appears for onboard Ethernet controllers. It does not appear for onboard InfiniBand* controllers.</p> <p>Ethernet controllers on IO Modules do not have a disabling function that can be controlled by BIOS, so there is no corresponding controller enable/disable option for an IOM Ethernet controller.</p>
NIC2 InfiniBand* Option ROM IOM1 InfiniBand* Option ROM	Enable Disable	Enable/Disable InfiniBand* Controller Option ROM and FlexBoot.	<p>This option will control whether the associated InfiniBand* Controller Option ROM is executed by BIOS during POST. This will also control whether the InfiniBand* controller FlexBoot program appears in the list of bootable devices.</p> <p>This option only appears for Onboard or IO Module InfiniBand* controllers. It does not appear for Ethernet controllers.</p>
NIC2 Port1 GUID IOM1 Port1 GUID		Information Only	16 hex digits of the Port1 GUID of the InfiniBand* controller for NIC2, IOM1, or IOM2.

Setup Item	Options	Help Text	Comments
NIC1 Port1 NIC1 Port2 NIC2 Port1 NIC2 Port2	Enable Disable	Enable/Disable Onboard NIC<n> Port<x>	<p>This will enable or disable Port<x, x = 1-4> of Onboard Network Controller<n, n = 1-2>, including associated Port PXE options. The NIC<n> Port<x> PXE option and MAC Address display will not appear when that port is disabled.</p> <p>The associated port enable/disable options will not appear when NIC<n> is disabled.</p> <p>Only ports which actually exist for a particular NIC will appear in this section. That is, Port1-Port4 will appear for a quad-port NIC, Port1-Port2 will appear for a dual-port NIC, and only Port1 will appear for a single-port NIC.</p> <p>Network controllers installed on an IO Module do not have a port disabling function that is controlled by BIOS, so there are no corresponding options for IO Module NICs.</p>
NIC1 Port1 PXE NIC1 Port2 PXE NIC2 Port1 PXE NIC2 Port2 PXE IOM1 Port1 PXE IOM1 Port2 PXE	Enable Disable	Enable/Disable Onboard/IOM NIC Port PXE Boot	This option will not appear for ports on a NIC which is disabled, or for individual ports when the corresponding NIC Port is disabled.
NIC1 Port1 MAC Address NIC1 Port2 MAC Address NIC2 Port1 MAC Address NIC2 Port2 MAC Address IOM1 Port1 MAC Address IOM1 Port2 MAC Address		Information Only	12 hex digits of the MAC address.

5.4.2.11 Serial Port Configuration

The Serial Port Configuration screen allows the user to configure the Serial A [COM 1] and Serial B [COM2] ports.

To access this screen from the **Main** screen, select **Advanced > Serial Port Configuration**. To move to another screen, press the <Esc> key to return to the **Advanced** screen, then select the desired screen.

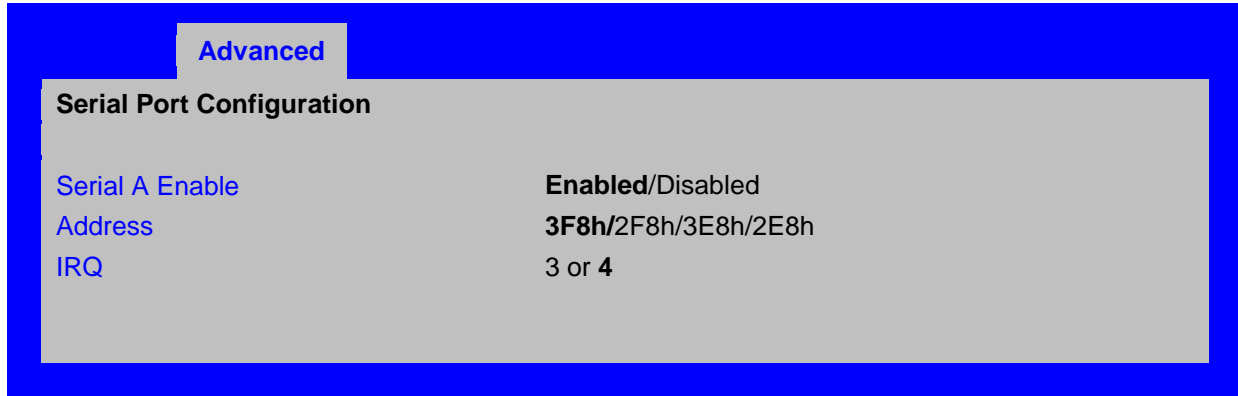

Figure 32. Serial Port Configuration Screen

Table 37. Setup Utility – Serial Ports Configuration Screen Fields

Setup Item	Options	Help Text
Serial A Enable	Enabled Disabled	Enable or Disable Serial port A.
Address	3F8h 2F8h 3E8h 2E8h	Select Serial port A base I/O address.
IRQ	3 4	Select Serial port A interrupt request (IRQ) line.

5.4.2.12 USB Configuration

The USB Configuration screen allows the user to configure the USB controller options.

To access this screen from the **Main** screen, select **Advanced > USB Configuration**. To move to another screen, press the <Esc> key to return to the **Advanced** screen, then select the desired screen.

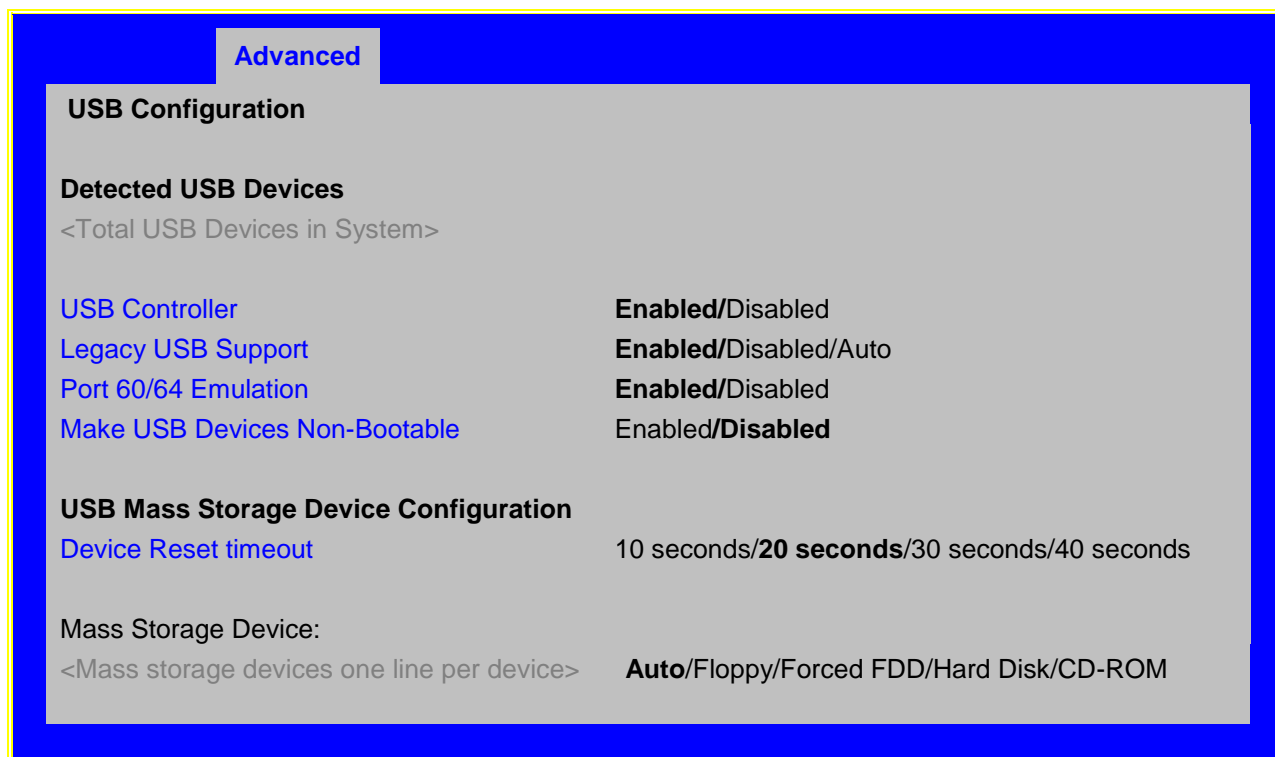

Figure 33. USB Configuration Screen

Table 38. Setup Utility – USB Controller Configuration Screen Fields

Setup Item	Options	Help Text	Comments
Detected USB Devices			Information only. Shows the number of USB devices in the system.
USB Controller	Enabled Disabled	[Enabled] - All onboard USB controllers are turned on and accessible by the OS. [Disabled] - All onboard USB controllers are turned off and inaccessible by the OS.	When <i>Legacy USB Support</i> is <i>Disabled</i> , USB devices are available only through OS drivers.
Legacy USB Support	Enabled Disabled Auto	USB device boot support and PS/2 emulation for USB keyboard and USB mouse devices. [Auto] - Legacy USB support is enabled if a USB device is attached.	Grayed out if the USB Controller is disabled.
Port 60/64 Emulation	Enabled Disabled	I/O port 60h/64h emulation support. Note: This may be needed for legacy USB keyboard support when using an OS that is USB unaware.	Grayed out if the USB Controller is disabled.
Make USB Devices Non-Bootable	Enabled Disabled	Exclude USB in Boot Table. [Enabled] - This removes all USB Mass Storage devices as Boot options. [Disabled] - This allows all USB Mass Storage devices as Boot options.	Grayed out if the USB Controller is disabled.

Setup Item	Options	Help Text	Comments
Device Reset timeout	10 sec 20 sec 30 sec 40 sec	USB Mass Storage device Start Unit command timeout. Setting to a larger value provides more time for a mass storage device to be ready, if needed.	Grayed out if the USB Controller is disabled.
Mass Storage Devices	Auto Floppy Forced FDD Hard Disk CD-ROM	[Auto] - USB devices less than 530 MB are emulated as floppies. [Forced FDD] - HDD formatted drive is emulated as an FDD (for example,, ZIP drive).	This field is hidden if no USB Mass Storage devices are detected. This setup screen can show a maximum of eight USB Mass Storage devices on the screen. If more than eight devices are installed in the system, the 'USB Devices Enabled' displays the correct count, but only the first eight devices discovered are displayed in this list.

5.4.2.13 System Acoustic and Performance Configuration

The System Acoustic and Performance Configuration screen allows the user to configure the thermal control behavior of the system with respect to what parameters are used in the system's Fan Speed Control algorithms.

To access this screen from the **Main** screen, select **Advanced > System Acoustic and Performance Configuration**. To move to another screen, press the <Esc> key to return to the **Advanced** screen, then select the desired screen.

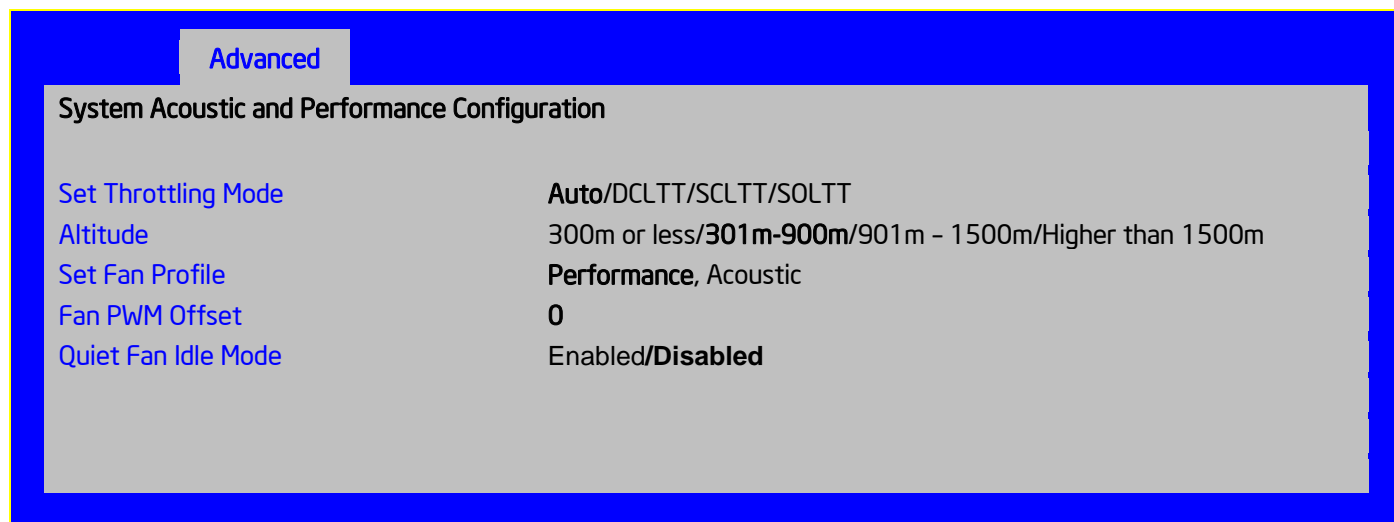

Figure 34. System Acoustic and Performance Configuration

Table 39. Setup Utility – System Acoustic and Performance Configuration Screen Fields

Setup Item	Options	Help Text	Comments
Set Throttling Mode	Auto DCLTT SCLTT SOLTT	[Auto] – Auto Throttling mode. [DCLTT] – Dynamic Closed Loop Thermal Throttling [SCLTT] – Static Closed Loop Thermal Throttling [SOLTT] – Static Open Loop Thermal Throttling	<u>DCLTT</u> is the expected mode for a board in an Intel chassis with inlet and outlet air temperature sensors and TSOD. The firmware can update the offset registers for closed loop during runtime, as BIOS sends the dynamic CLTT offset temperature data. <u>SCLTT</u> would be used with an OEM chassis and DIMMs with TSOD. The firmware does not change the offset registers for closed loop during runtime, although the Management Engine can do so. <u>SOLTT</u> is intended for a system with UDIMMs which do not have TSOD. The thermal control registers are configured during POST, and the firmware does not change them.
Altitude	300m or less 301m-900m 901m-1500m Higher than 1500m	[300m or less] (980ft or less) Optimal performance setting near sea level. [301m - 900m] (980ft - 2950ft) Optimal performance setting at moderate elevation. [901m – 1500m] (2950ft – 4920ft) Optimal performance setting at high elevation. [Higher than 1500m] (4920ft or greater) Optimal performance setting at the highest elevations.	This option sets an altitude value in order to choose a Fan Profile that is optimized for the air density at the current altitude at which the system is installed.

Setup Item	Options	Help Text	Comments
Set Fan Profile	Performance Acoustics	<p>[Performance] - Fan control provides primary system cooling before attempting to throttle memory.</p> <p>[Acoustic] - The system will favor using throttling of memory over boosting fans to cool the system if thermal thresholds are met.</p>	<p>This option allows the user to choose a Fan Profile that is optimized for maximizing performance or for minimizing acoustic noise.</p> <p>When <i>Performance</i> is selected, the thermal conditions in the system are controlled by raising fan speed when necessary to raise cooling performance. This provides cooling without impacting system performance, but may impact system acoustic performance – fans running faster are typically louder.</p> <p>When <i>Acoustic</i> is selected, then rather than increasing fan speed for additional cooling, the system will attempt first to control thermal conditions by throttling memory to reduce heat production. This regulates the system's thermal condition without changing the acoustic performance, but throttling memory may impact system performance.</p>
Fan PWM Offset	0	Valid Offset 0 - 100. This number is added to the calculated PWM value to increase Fan Speed.	This is a percentage by which the calculated fan speed will be increased. The user can apply positive offsets that result in increasing the minimum fan speeds.

Setup Item	Options	Help Text	Comments
Quiet Fan Idle Mode	Disabled Enabled	Enabling this option allows the system fans to operate in Quiet 'Fan off' mode while still maintaining sufficient system cooling. In this mode, fan sensors become unavailable and cannot be monitored. There will be limited fan related event generation.	When enabled, this option allows fans to idle or turn off when sufficient thermal margin is available, decreasing the acoustic noise produced by the system and decreasing system power consumption. Fans will run as needed to maintain thermal control. The actual decrease in fan speed depends on the system thermal loading, which in turn depends on system configuration and workload. While Quiet Fan Idle Mode is engaged, fan sensors become unavailable and are not monitored by the BMC.

5.4.2.14 Security Screen (Tab)

The Security screen allows the user to enable and set the user and administrative password and to lock out the front panel buttons so they cannot be used. This screen also allows the user to enable and activate the Trusted Platform Module (TPM) security settings on those boards that support TPM.

To access this screen from the **Main** screen or other top-level **Tab** screen, press the right or left arrow keys to traverse the tabs at the top of the **Setup** screen until the **Security** screen is selected.

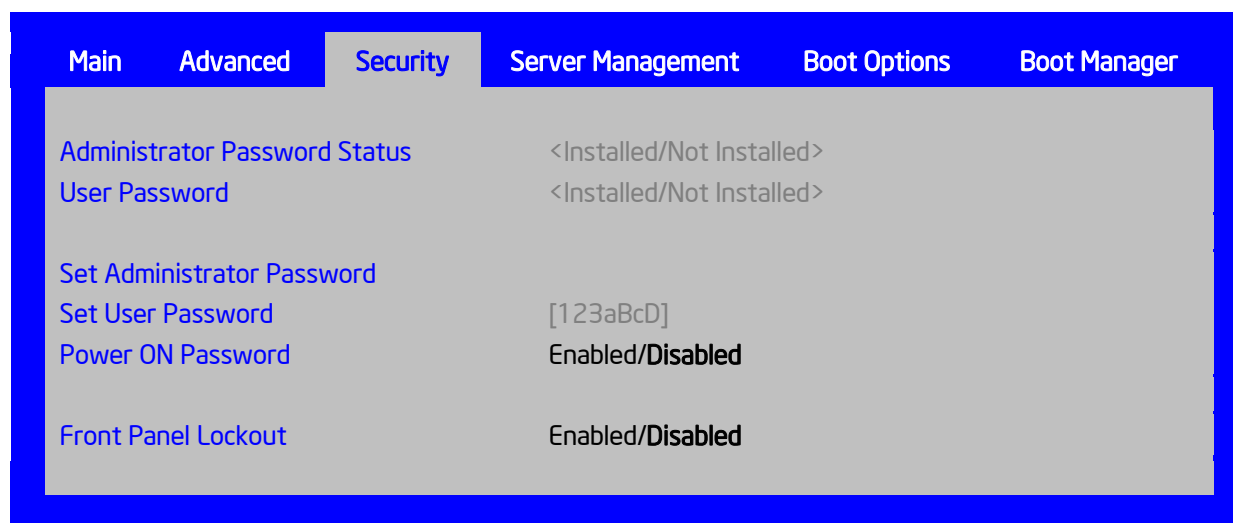

Figure 35. Security Screen

Table 40. Setup Utility – Security Configuration Screen Fields

Setup Item	Options	Help Text	Comments
Administrator Password Status	Installed Not Installed		Information only. Indicates the status of the administrator password.
User Password Status	Installed Not Installed		Information only. Indicates the status of the user password.
Set Administrator Password	[Entry Field]	Administrator password is used to control change access in BIOS Setup Utility. Only alphanumeric characters can be used. Maximum length is 7 characters. It is case sensitive. Note: Administrator password must be set in order to use the user account.	This option is only to control access to the setup. Administrator has full access to all the setup items. Clearing the Administrator password also clears the user password.
Set User Password	[Entry Filed]	User password is used to control entry access to BIOS Setup Utility. Only alphanumeric characters can be used. Maximum length is 7 characters. It is case sensitive. Note: Removing the administrator password also automatically removes the user password.	Available only if the administrator password is installed. This option only protects the setup. User password only has limited access to the setup items.
Power ON Password	Enabled Disabled	Enable Power On Password support. If enabled, password entry is required in order to boot the system	When Power On Password security is enabled, the system will halt soon after power on and the BIOS will ask for a password before continuing POST and booting. Either the Administrator or User password may be used. If an Administrator password has not been set, this option will be grayed out and unavailable. If this option is enabled and the Administrator password is removed, that will also disable this option.
Front Panel Lockout	Enabled Disabled	If enabled, locks the power button and reset button on the system's front panel. If [Enabled] is selected, power and reset must be controlled through a system management interface.	

5.4.2.15 Server Management Screen (Tab)

The Server Management screen allows the user to configure several server management features. This screen also provides an access point to the screens for configuring console redirection, displaying system information, and controlling the BMC LAN configuration.

To access this screen from the **Main** screen or other top-level **Tab** screen, press the right or left arrow keys to traverse the tabs at the top of the **Setup** screen until the **Server Management** screen is selected.



Figure 36. Server Management Screen

Table 41. Setup Utility – Server Management Configuration Screen Fields

Setup Item	Options	Help Text	Comments
Assert NMI on SERR	Enabled Disabled	On SERR, generate an NMI and log an error. Note: [Enabled] must be selected for the Assert NMI on PERR setup option to be visible.	

Setup Item	Options	Help Text	Comments
Assert NMI on PERR	Enabled Disabled	On PERR, generate an NMI and log an error. Note: This option is only active if the Assert NMI on SERR option is [Enabled] selected.	
Reset on CATERR	Enabled Disabled	When enabled system gets reset upon encountering Catastrophic Error (CATERR); when disabled system does not get reset on CATERR.	This option controls whether the system will be reset when the CATERR signal is held asserted, rather than just pulsed to generate an SMI.
Reset on ERR2	Enabled Disabled	When enabled system gets reset upon encountering ERR2 (Fatal error); when disabled system does not get reset on ERR2	This option controls whether the system will be reset if the BMC's ERR2 Monitor times out, that is, the ERR2 signal has been continuously asserted long enough to indicate that the SMI Handler is not able to service the condition.
Resume on AC Power Loss	Stay Off Last state Reset	System action to take on AC power loss recovery. [Stay Off] - System stays off. [Last State] - System returns to the same state before the AC power loss. [Reset] - System powers on.	
Clear System Event Log	Enabled Disabled	If enabled, clears the System Event Log. All current entries will be lost. Note: This option is reset to [Disabled] after a reboot.	
FRB-2 Enable	Enabled Disabled	Fault Resilient Boot (FRB). If enabled, the BIOS programs the BMC watchdog timer for approximately 6 minutes. If the BIOS does not complete POST before the timer expires, the BMC resets the system.	
O/S Boot Watchdog Timer	Enabled Disabled	If enabled, the BIOS programs the watchdog timer with the timeout value selected. If the OS does not complete booting before the timer expires, the BMC resets the system and an error is logged. Requires OS support or Intel Management Software.	
O/S Boot Watchdog Timer Policy	Power Off Reset	If the OS boot watchdog timer is enabled, this is the system action taken if the watchdog timer expires. [Reset] - System performs a reset. [Power Off] - System powers off.	Grayed out when the O/S Boot Watchdog Timer is disabled.
O/S Boot Watchdog Timer Timeout	5 minutes 10 minutes 15 minutes 20 minutes	If the OS watchdog timer is enabled, this is the timeout value used by the BIOS to configure the watchdog timer.	Grayed out when the O/S Boot Watchdog Timer is disabled.

Setup Item	Options	Help Text	Comments
Plug and Play BMC Detection	Enabled Disabled	If enabled, the BMC is detectable by OSs that support plug and play loading of an IPMI driver. Do not enable if your OS does not support this driver.	
Shutdown Policy	Enabled Disabled	Enable/Disable Shutdown Policy	This option is designed for multiple-node system and to control the policy that BMC should shut down one node if it detected over-current or over-temperature condition. The BIOS and the BMC will synchronize the policy during the BIOS POST and current value of the BMC will be displayed in BIOS Setup. This option only shows on Node 3 and Node 4
Console Redirection		View/Configure console redirection information and settings.	Takes the user to the Console Redirection screen.
System Information		View system information	Takes the user to the System Information screen.
BMC LAN Configuration		View/Configure BMC LAN channel and user settings	Takes the user to the BMC configuration screen.

5.4.2.16 Console Redirection

The Console Redirection screen allows the user to enable or disable Console Redirection for Remote Management, and to configure the connection options for this feature.

To access this screen from the **Main** screen, select **Server Management > Console Redirection**. To move to another screen, press the <Esc> key to return to the **Server Management** screen, then select the desired screen.

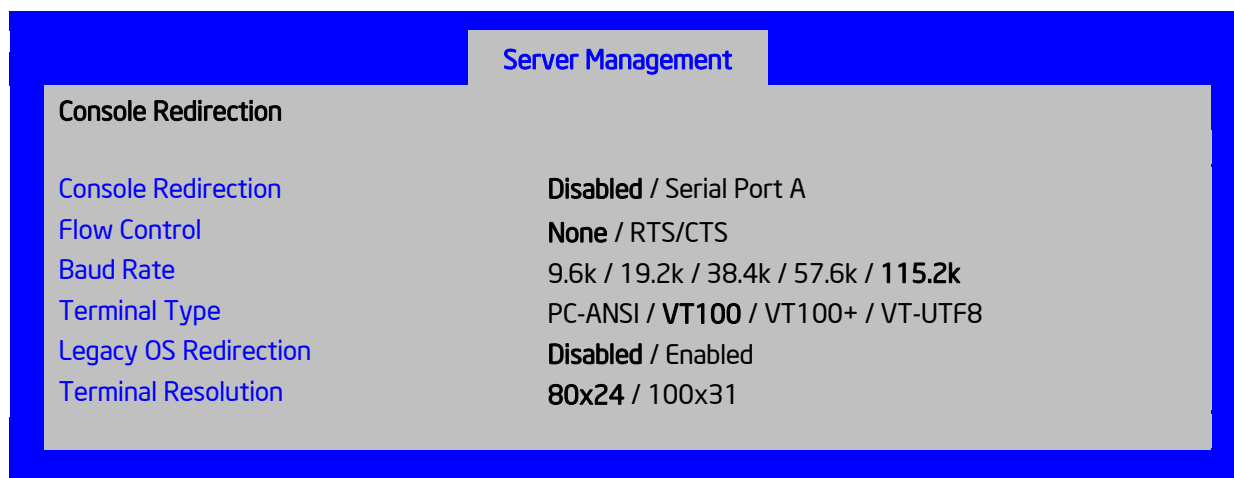

Figure 37. Console Redirection Screen

Table 42. Setup Utility – Console Redirection Configuration Fields

Setup Item	Options	Help Text
Console Redirection	Disabled Serial Port A	Console redirection allows a serial port to be used for server management tasks. [Disabled] - No console redirection. [Serial Port A] - Configure serial port A for console redirection. Enabling this option disables the display of the Quiet Boot logo screen during POST.
Flow Control	None RTS/CTS	Flow control is the handshake protocol. Setting must match the remote terminal application. [None] - Configure for no flow control. [RTS/CTS] - Configure for hardware flow control.
Baud Rate	9600 19.2K 38.4K 57.6K 115.2K	Serial port transmission speed. Setting must match the remote terminal application.
Terminal Type	PC-ANSI VT100 VT100+ VT-UTF8	Character formatting used for console redirection. Setting must match the remote terminal application.
Legacy OS Redirection	Disabled Enabled	This option enables legacy OS redirection (i.e., DOS) on serial port. If it is enabled, the associated serial port is hidden from the legacy OS.
Terminal Resolution	80x24 100x31	Terminal screen resolution for console redirection.

5.4.2.17 System Information

The System Information screen allows the user to view part numbers, serial numbers, and firmware revisions. This is an **Information Only** screen

To access this screen from the **Main** screen, select **Server Management > System Information**. To move to another screen, press the <Esc> key to return to the **Server Management** screen, then select the desired screen.

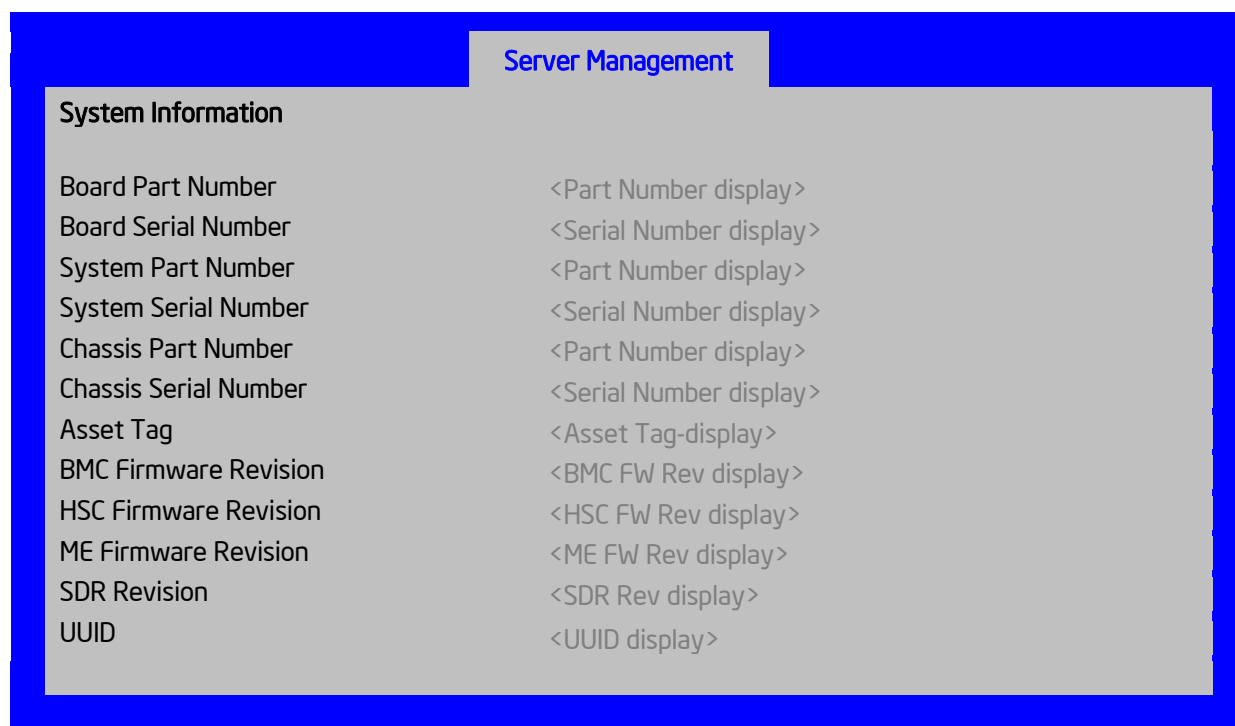

Figure 38. System Information Screen

Table 43. Setup Utility – Server Management System Information Fields

Setup Item	Help Text	Comments
Board Part Number		Information only
Board Serial Number		Information only
System Part Number		Information only.
System Serial Number	Press <Enter> to edit system Serial Number and then use Backspace to delete existing value. Maximum length is 20 characters	Information only.
Chassis Part Number		Information only.
Chassis Serial Number		Information only.
Asset Tag	Press <Enter> to edit system Serial Number and then use Backspace to delete existing value. Maximum length is 20 characters	Information only.
BMC Firmware Revision		Information only
HSC Firmware Revision		Information only. If there is no HSC installed, the Firmware Revision Number appears as "0,00".
ME Firmware Revision		Information only.
SDR Revision		Information only
UUID		Information only

5.4.2.18 BMC LAN Configuration

The BMC configuration screen allows the Setup user to configure the BMC Baseboard LAN channel and the RMM4 LAN channel, and to manage BMC User settings for up to five BMC Users.

To access this screen from the **Main** screen, select **Server Management > System Information**. To move to another screen, press the <Esc> key to return to the **Server Management** screen, then select the desired screen.



Figure 39. BMC LAN Configuration Screen

Table 44. Setup Utility — BMC configuration Screen Fields

Setup Item	Options	Help Text	Comments
IP source	Static Dynamic	Select BMC IP source. When Static option is selected, IP address, subnet mask and gateway are editable. When Dynamic option selected, these fields are read-only and IP is address acquired automatically (DHCP).	
IP address		View/Edit IP address. Press <Enter> to edit.	
Subnet Mask		View/Edit subnet address. Press <Enter> to edit.	
Gateway IP		View Edit Gateway IP address. Press <Enter> to edit.	
Intel® RMM4	Present Not Present		Information Only
IP source	Static Dynamic	Select BMC IP source. When Static option is selected, IP address, subnet mask and gateway are editable. When Dynamic option selected, these fields are read-only and IP is address acquired automatically (DHCP).	
IP address		View/Edit IP address. Press <Enter> to edit.	
Subnet Mask		View/Edit subnet address. Press <Enter> to edit.	
Gateway IP		View Edit Gateway IP address. Press <Enter> to edit.	
BMC DHCP Host Name		View/Edit BMC DHCP host name. Press <Enter> to edit.	Available only when IP source for any one channel is dynamic option.
User ID	anonymous root User3 User4 User5	Select the user id to configure.	
Privilege	Callback User Operator Administrator	View/Select user privilege	
User Status	Enable Disable	Enable/Disable LAN access for selected user. Also enables/disables SOL, KVM media redirection.	
User Name		Press <Enter> to edit user name. User name is string of 4 to 15 alphanumeric characters. User name must begin with an alphabetic character.	
User Password		Press <Enter> Key to enter password. Only alphanumeric characters can be used. Maximum length is 15 characters and case sensitive. Note: Password entered will override any previously set password.	This field will not indicate whether there is password set already.

5.4.2.19 Boot Options Screen (Tab)

The Boot Options screen displays all bootable media encountered during POST, and allows the user to configure the desired order in which boot devices are to be tried.

The first boot device in the specified Boot Order which is present and is bootable during POST will be used to boot the system, and will continue to be used to reboot the system until the boot device configuration has changed (that is, which boot devices are present), or until the system has been powered down and booted in a “cold” power-on boot.

If all types of bootable devices are installed in the system, then the default boot order is as follows:

- CD/DVD-ROM
- Floppy Disk Drive
- Hard Disk Drive
- PXE Network Device
- BEV (Boot Entry Vector) Device
- EFI Shell and EFI Boot paths

To access this screen from the **Main** screen or other top-level “Tab” screen, press the right or left arrow keys to traverse the tabs at the top of the **Setup** screen until the **Boot Options** screen is selected.

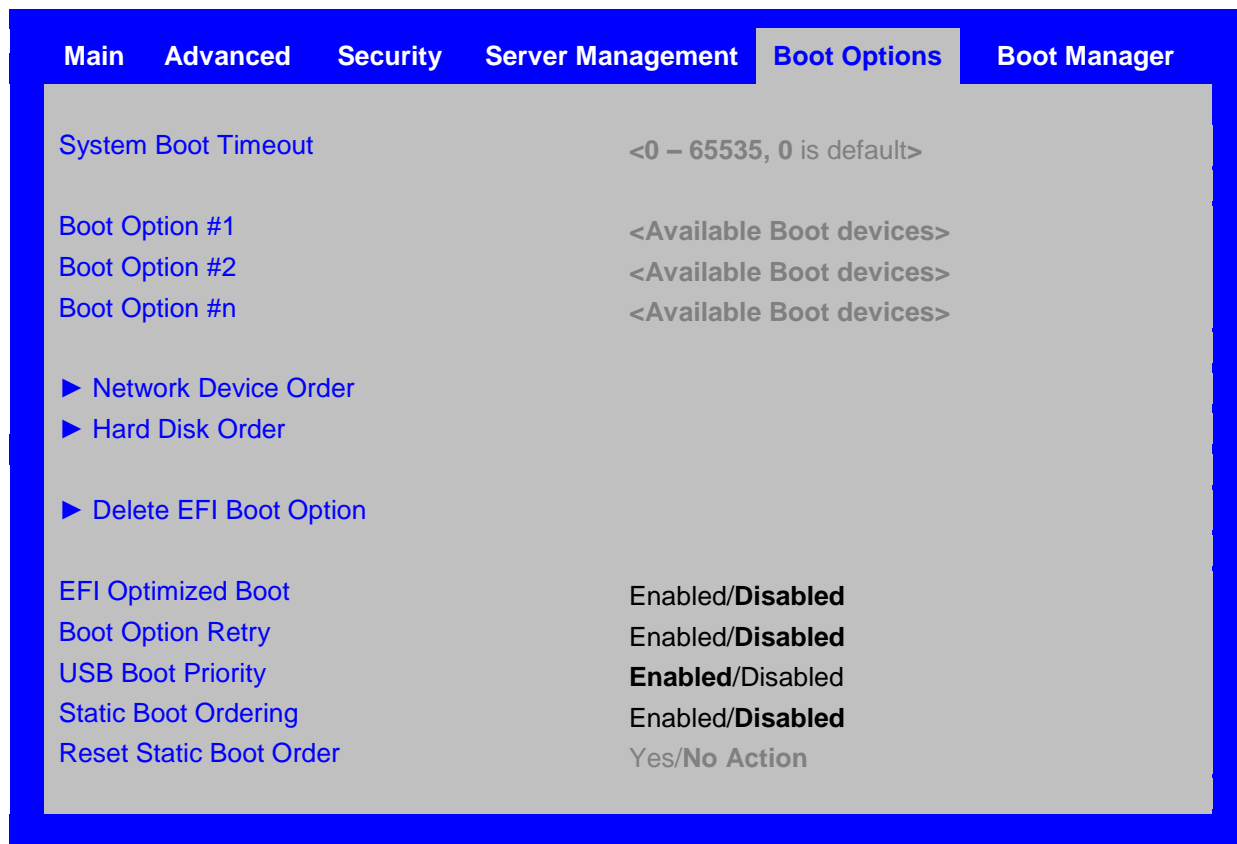

Figure 40. Boot Options Screen

Table 45. Setup Utility – Boot Options Screen Fields

Setup Item	Options	Help Text	Comments
Boot Timeout	0 - 65535	The number of seconds the BIOS should pause at the end of POST to allow the user to press the [F2] key for entering the BIOS Setup utility. Valid values are 0-65535. Zero is the default. A value of 65535 causes the system to go to the Boot Manager menu and wait for user input for every system boot.	After entering the necessary timeout, press the Enter key to register that timeout value to the system. These settings are in seconds.
Boot Option #x	Available boot devices.	Set system boot order by selecting the boot option for this position.	
Hard Disk Order		Set the order of the legacy devices in this group.	Displays when one or more hard disk drives are in the system.
Network Device Order		Set the order of the legacy devices in this group.	Displays when one or more of these devices are available in the system.
Delete Boot Option		Remove an EFI boot option from the boot order.	If the EFI shell is deleted, it is restored on the next system reboot. It cannot be permanently deleted.
EFI Optimized Boot	Enabled Disabled	If enabled, the BIOS only loads modules required for booting EFI-aware Operating Systems.	Grayed out when [SW RAID] SATA Mode is Enabled. SW RAID can only be used in Legacy Boot mode.
Boot Option Retry	Enabled Disabled	If enabled, this continually retries non-EFI-based boot options without waiting for user input.	
USB Boot Priority	Enabled Disabled	If enabled newly discovered USB devices will be put to the top of their boot device category. If disabled newly discovered USB devices will be put at the bottom of the respective list	
Static Boot Ordering	Enabled Disabled	[Disabled] - Devices removed from the system are deleted from Boot Order Tables. [Enabled] - Devices removed have positions in Boot Order Tables retained for later reinsertion.	When the option changes to “Enabled” from “Disabled”, it will enable Static Boot Ordering (SBO) from the next boot onward, and also the current Boot Order will be stored as the SBO template. When the option changes to “Disabled” from “Enabled”, it will disable SBO and the SBO template will be cleared. Otherwise it will retain the current Enabled/Disabled

Setup Item	Options	Help Text	Comments
			state.
Reset Static Boot Order	Yes No Action	[Yes] Take snapshot of current boot order to save as Static Boot Order Template.	This option will allow you to take the current Boot Options and save it as the Static Boot Option template without disabling and re-enabling the Static Boot Ordering option. Select "Yes" to snapshot the current Boot Options into the Static Boot Options. After saving SBO, on next boot this option will change back to "No Action" automatically.

5.4.2.20 Hard Disk Order

The Hard Disk Order screen allows the user to control the order in which BIOS attempts to boot from the hard disk drives installed in the system. This screen is only available when there is at least one hard disk device available in the system configuration. Note that a USB attached Hard Disk drive or a USB Key device formatted as a hard disk will appear in this section.

To access this screen from the **Main** screen, select **Boot Options > Hard Disk Order**. To move to another screen, press the <Esc> key to return to the **Boot Options** screen, then select the desired screen.

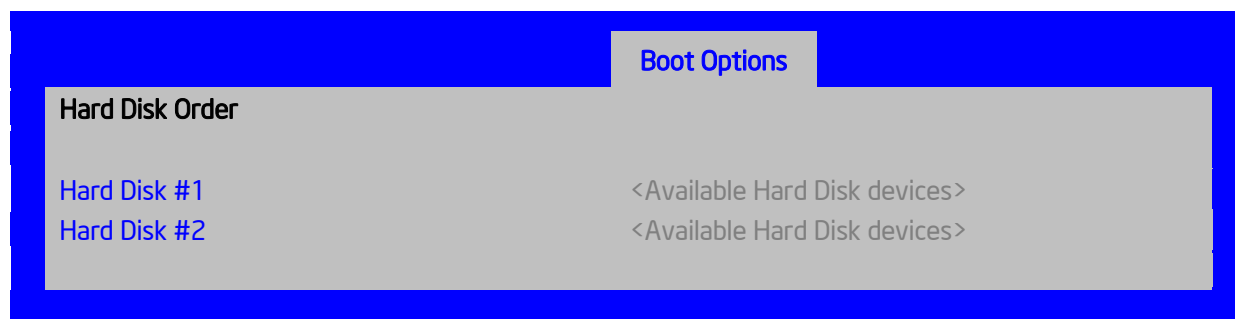

Figure 41. Hard Disk Order Screen

Table 46. Setup Utility — Hard Disk Order Fields

Setup Item	Options	Help Text
Hard Disk #1	Available Legacy devices for this Device group.	Set system boot order by selecting the boot option for this position.
Hard Disk #2	Available Legacy devices for this Device group.	Set system boot order by selecting the boot option for this position.

5.4.2.21 Network Device Order

The Network Device Order screen allows the user to control the order in which BIOS attempts to boot from the network bootable devices installed in the system. This screen is only available when there is at least one network bootable device available in the system configuration.

To access this screen from the **Main** screen, select **Boot Options > Network Device Order**. To move to another screen, press the <Esc> key to return to the **Boot Options** screen, then select the desired screen.

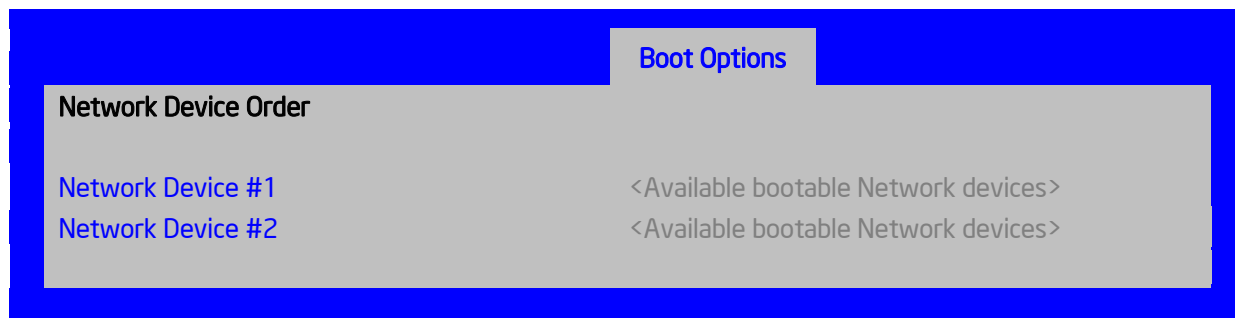

Figure 42. Network Device Order Screen

Table 47. Setup Utility — Network Device Order Fields

Setup Item	Options	Help Text
Network Device #1	Available Legacy devices for this Device group.	Set system boot order by selecting the boot option for this position.
Network Device #2	Available Legacy devices for this Device group.	Set system boot order by selecting the boot option for this position.

5.4.2.22 Delete EFI Boot Option

The Delete EFI Boot Option screen allows the user to remove an EFI boot option from the boot order. The “Internal EFI Shell” Boot Option will not be listed, since it is permanent and cannot be added or deleted.

To access this screen from the **Main** screen, select **Boot Options > Delete EFI Boot Option**. To move to another screen, press the <Esc> key to return to the **Boot Options** screen, then select the desired screen.

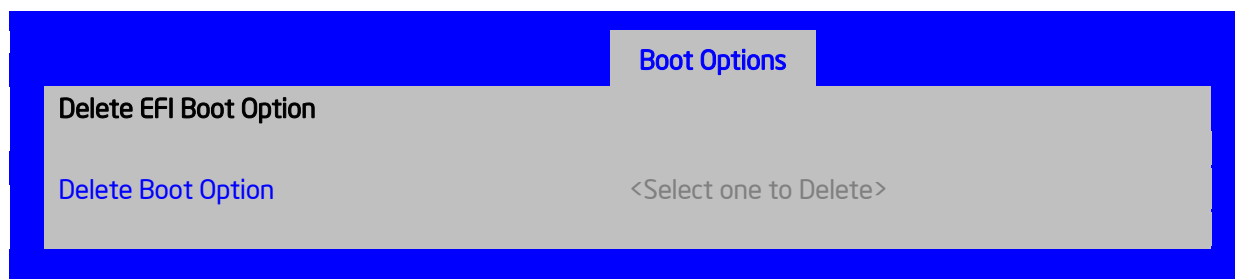

Figure 43. Delete EFI Boot Option Screen

Table 48. Setup Utility – Delete Boot Option Fields

Setup Item	Options	Help Text
Delete Boot Option	Select one to Delete Internal EFI Shell	Remove an EFI boot option from the boot order.

5.4.2.23 Boot Manager Screen (Tab)

The Boot Manager screen allows the user to view a list of devices available for booting, and to select a boot device for immediately booting the system. Note that this list is *not* in order according to the system Boot Option order. The “Internal EFI Shell” will always be available, regardless of whether any other bootable devices are available.

To access this screen from the **Main** screen or other top-level “Tab” screen, press the right or left arrow keys to traverse the tabs at the top of the Setup screen until the **Boot Manager** screen is selected.

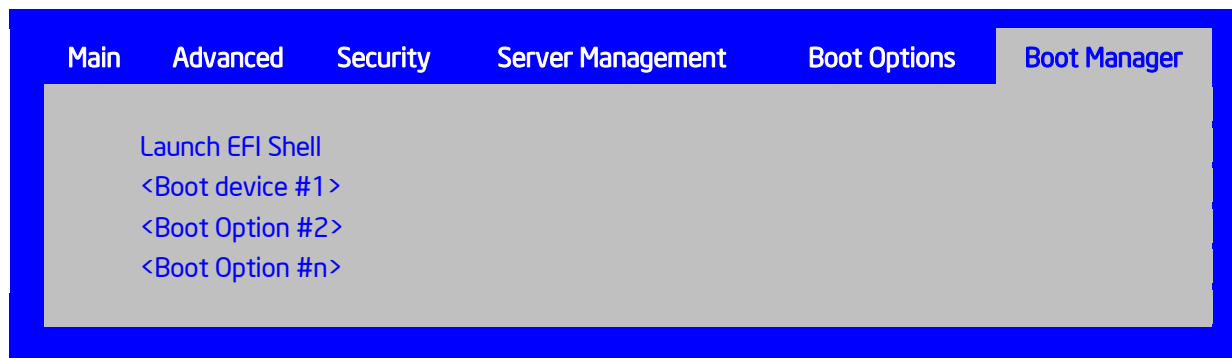

Figure 44. Boot Manager Screen

Table 49. Setup Utility – Boot Manager Screen Fields

Setup Item	Help Text
Launch EFI Shell	Select this option to boot now. Note: This list is not the system boot option order. Use the Boot Options menu to view and configure the system boot option order.
Boot Device #n	Select this option to boot now. Note: This list is not the system boot option order. Use the Boot Options menu to view and configure the system boot option order.

5.4.2.24 Error Manager Screen (Tab)

The Error Manager screen displays any POST Error Codes encountered during BIOS POST, along with an explanation of the meaning of the Error Code in the form of a Help Text. This is an **Information Only** screen.

To access this screen from the **Main** screen or other top-level “Tab” screen, press the right or left arrow keys to traverse the tabs at the top of the Setup screen until the **Error Manager** screen is selected.



Figure 45. Error Manager Screen

Table 50. Setup Utility — Error Manager Screen Fields

Setup Item	Options	Help Text	Comments
Displays System Errors			Information only. Displays errors that occurred during POST.

5.4.2.25 Save and Exit Screen (Tab)

The Exit screen allows the user to choose whether to save or discard the configuration changes made on other Setup screens. It also allows the user to restore the BIOS settings to the factory defaults or to save or restore them to a set of user-defined default values. If Load Default Values is selected, the factory default settings (noted in bold in the Setup screen images) are applied. If Load User Default Values is selected, the system is restored to previously saved user-defined default values.

To access this screen from the **Main** screen or other top-level **Tab** screen, press the right or left arrow keys to traverse the tabs at the top of the **Setup** screen until the **Exit** screen is selected.

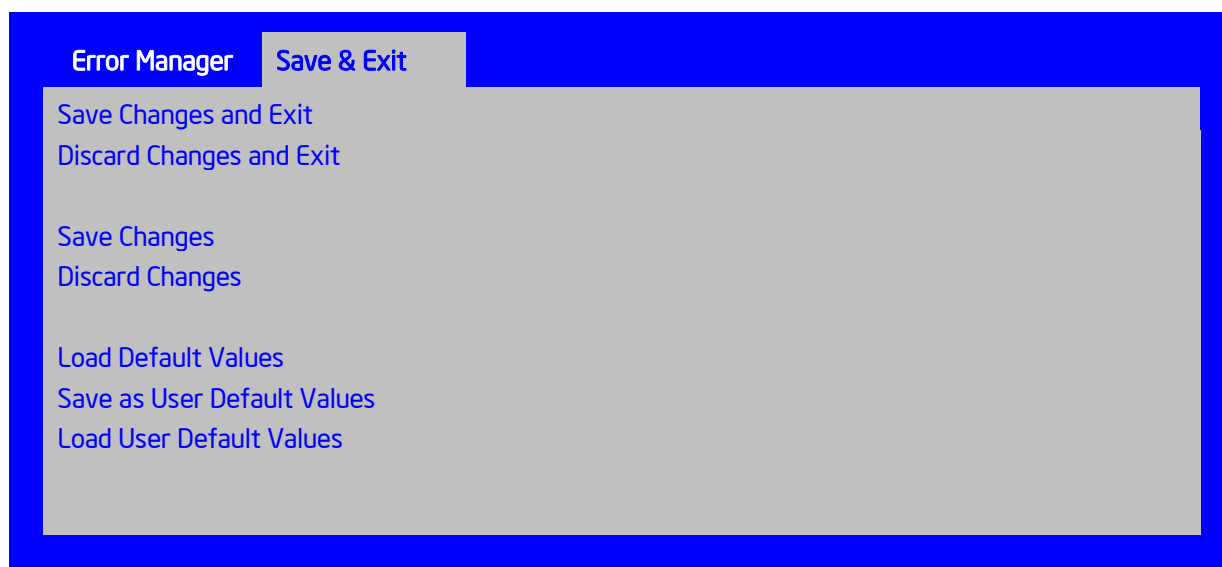

Figure 46. Exit Screen

Table 51. Setup Utility — Exit Screen Fields

Setup Item	Help Text	Comments
Save Changes and Exit	Exit the BIOS Setup utility after saving changes. The system reboots if required. The [F10] key can also be used.	User prompted for confirmation only if any of the setup fields were modified.
Discard Changes and Exit	Exit the BIOS Setup utility without saving changes. The [Esc] key can also be used.	User prompted for confirmation only if any of the setup fields were modified.
Save Changes	Save changes without exiting the BIOS Setup Utility. Note: Saved changes may require a system reboot before taking effect.	User prompted for confirmation only if any of the setup fields were modified.
Discard Changes	Discard changes made since the last Save Changes operation was performed.	User prompted for confirmation only if any of the setup fields were modified.
Load Default Values	Load factory default values for all BIOS Setup utility options. The [F9] key can also be used.	User prompted for confirmation.

Setup Item	Help Text	Comments
Save as User Default Values	Save current BIOS Setup utility values as custom user default values. If needed, the user default values can be restored through the Load User Default Values option below. Note: Clearing the CMOS or NVRAM does not cause the User Default values to be reset to the factory default values.	User prompted for confirmation.
Load User Default Values	Load user default values.	User prompted for confirmation.

5.5 Loading BIOS Defaults

Different mechanisms exist for resetting the system configuration to the default values. When a request to reset the system configuration is detected, the BIOS loads the default system configuration values during the next POST. You can send the request to reset the system to the defaults in the following ways:

- Pressing <F9> from within the BIOS Setup utility.
- Moving the clear system configuration jumper.
- IPMI command (set System Boot options command)
- Int15 AX=DA209
- Choosing Load User Defaults from the Exit page of the BIOS Setup loads user set defaults instead of the BIOS factory defaults.

The recommended steps to load the BIOS defaults are:

1. Power down the system (Do not remove AC power).
2. Move the BIOS DFLT jumper from pins 1-2 to pins 2-3.
3. Move the BIOS DFLT jumper from pins 2-3 to pins 1-2.
4. Power up the system.

6. Configuration Jumpers

The following table provides a summary and description of configuration, test, and debug jumpers on the Intel® Server Board S2600WP. The server board has several three-pin jumper blocks that can be used.

Pin 1 on each jumper block can be identified by the following symbol on the silkscreen:

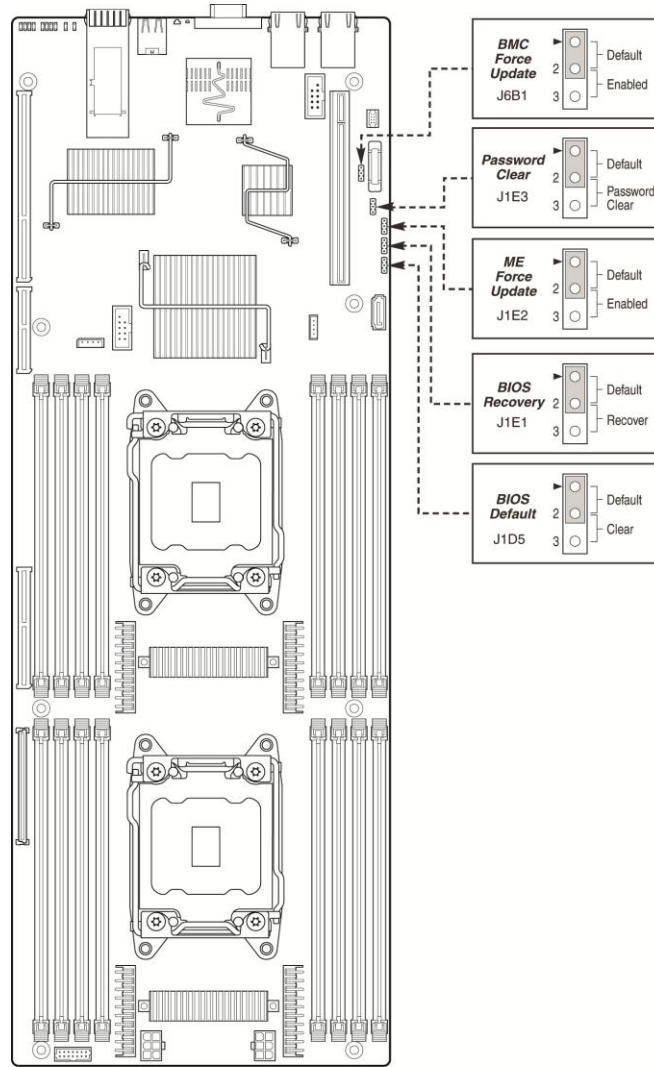

AF004672

Figure 47. Jumper Blocks (J6B1, J1E2, J1E3, J1E1, J1D5)

Table 52. Server Board Jumpers (J6B1, J1E2, J1E3, J1E1, J1D5)

Jumper Name	Jumper Position	Mode of Operation	Note
J6B1: BMC Force Update jumper	1-2	Normal	Normal mode
	2-3	Update	BMC in force update mode

Jumper Name	Jumper Position	Mode of Operation	Note
J1E2: ME Force Update	1-2	Normal	Normal mode
	2-3	Update	ME in force update mode
J1E3: Password Clear	1-2	Normal	Normal mode, password in protection
	2-3	Clear Password	BIOS password is cleared
J1E1: BIOS Recovery Mode	1-2	Normal	Normal mode
	2-3	Recovery	BIOS in recovery mode
J1D5: BIOS Default	1-2	Normal	Normal mode
	2-3	Clear BIOS Settings	BIOS settings are reset to factory default

6.1.1 Force Integrated BMC Update (J6B1)

When performing a standard BMC firmware update procedure, the update utility places the BMC into an update mode, allowing the firmware to load safely onto the flash device. In the unlikely event the BMC firmware update process fails due to the BMC not being in the proper update state, the server board provides a BMC Force Update jumper (J6B1) which will force the BMC into the proper update state. The following procedure should be followed in the event the standard BMC firmware update process fails.

Table 53. Force Integrated BMC Update Jumper

Jumper Position	Mode of Operation	Note
1-2	Normal	Normal operation
2-3	Update	BMC in force update mode

Steps to perform Force BMC Update:

1. Power down and remove the AC power cord.
2. Open the server chassis. See your server chassis documentation for instructions.
3. Move jumper from the default operating position, covering pins 1 and 2, to the enabled position, covering pins 2 and 3.
4. Close the server chassis.
5. Reconnect the AC cord and power up the server.
6. Perform the BMC firmware update procedure as documented in the *ReleaseNote.TXT* file included in the given BMC firmware update package. After successful completion of the firmware update process, the firmware update utility may generate an error stating the BMC is still in update mode.
7. Power down and remove the AC power cord.
8. Open the server chassis.
9. Move the jumper from the enabled position, covering pins 2 and 3 to the disabled position, covering pins 1 and 2.
10. Close the server chassis.
11. Reconnect the AC cord and power up the server.

Note: Normal BMC functionality is disabled with the Force BMC Update jumper is set to the enabled position. You should never run the server with the BMC Force Update jumper set in this position. You should only use this jumper setting when the standard firmware update process

fails. This jumper should remain in the default/disabled position when the server is running normally.

The server board has several 3-pin jumper blocks that can be used to configure, protect, or recover specific features of the server board.

6.1.2 Force ME Update (J1E2)

When this 3-pin jumper is set, it manually puts the ME firmware in update mode, which enables the user to update ME firmware code when necessary.

Table 54. Force ME Update Jumper

Jumper Position	Mode of Operation	Note
1-2	Normal	Normal operation
2-3	Update	ME in force update mode

Note: Normal ME functionality is disabled with the Force ME Update jumper is set to the enabled position. You should never run the server with the ME Force Update jumper set in this position. You should only use this jumper setting when the standard firmware update process fails. This jumper should remain in the default/disabled position when the server is running normally.

Steps to perform the Force ME Update:

1. Power down and remove the AC power cord.
2. Open the server chassis. For instructions, see your server chassis documentation.
3. Move jumper from the default operating position (covering pins 1 and 2) to the enabled position (covering pins 2 and 3).
4. Close the server chassis.
5. Reconnect the AC cord and power up the server.
6. Perform the ME firmware update procedure as documented in the README.TXT file that is included in the given ME firmware update package (same package as BIOS).
7. Power down and remove the AC power cord.
8. Open the server chassis.
9. Move jumper from the enabled position (covering pins 2 and 3) to the disabled position (covering pins 1 and 2).
10. Close the server chassis.

6.1.3 Password Clear (J1E3)

The user sets this 3-pin jumper to clear the password.

Table 55. Password Clear Jumper

Jumper Position	Mode of Operation	Note
1-2	Normal	Normal mode, password in protection
2-3	Clear Password	BIOS password is cleared

Steps to clear the BIOS password:

1. Power down server. Do not unplug the power cord.
2. Open the chassis. For instructions, see your server chassis documentation.
3. Move jumper (J1B6) from the default operating position, covering pins 1 and 2, to the password clear position, covering pins 2 and 3.
4. Close the server chassis.
5. Power up the server, wait 10 seconds or POST completes.
6. Power down the server.
7. Open the chassis and move the jumper back to default position, covering pins 1 and 2.
8. Close the server chassis.
9. Power up the server.

The password is now cleared and you can reset it by going into the BIOS setup.

6.1.4 BIOS Recovery Mode (J1E1)

The Intel® Server Board S2600WP uses BIOS recovery to repair the system BIOS from flash corruption in the main BIOS and Boot Block. This 3-pin jumper is used to reload the BIOS when the image is suspected to be corrupted. For directions on how to recover the BIOS, refer to the specific BIOS release notes.

Table 56. BIOS Recovery Mode Jumper

Jumper Position	Mode of Operation	Note
1-2	Normal	Normal mode
2-3	Recovery	BIOS in recovery mode

You can accomplish a BIOS recovery from the SATA CD and USB Mass Storage device. Please note that this platform does not support recovery from a USB floppy.

The recovery media must contain the following files under the root directory:

1. RML.ROM
2. UEFI iFlash32 11.0 Build 2 (including iFlash32.efi and ipmi.efi)
3. *Rec.CAP
4. Startup.nsh (update accordingly to use proper *Rec.CAP file)

The BIOS starts the recovery process by first loading and booting to the recovery image file (RML.ROM) on the root directory of the recovery media (USB disk). This process takes place before any video or console is available. Once the system boots to this recovery image file (FVMAIN.FV), it boots automatically into the EFI Shell to invoke the Startup.nsh script and start the flash update application (IFlash32.efi). IFlash32.efi requires the supporting BIOS Capsule image file (*Rec.CAP).

After the update is complete, a message displays, stating the “BIOS has been updated successfully”. This indicates the recovery process is finished.

The user should then switch the recovery jumper back to normal operation and restart the system by performing a power cycle.

The following steps demonstrate this recovery process:

1. Power OFF the system.
2. Insert recovery media.
3. Switch the recovery jumper. Details regarding the jumper ID and location can be obtained from the Board EPS for that Platform.
4. Power ON the system.
5. The BIOS POST screen will appear displaying the progress, and the system automatically boots to the EFI SHELL.
6. The Startup.nsh file executes, and initiates the flash update (IFlash32.efi) with a new capsule file (*Rec.CAP). The regular iFlash message displays at the end of the process—once the flash update succeeds.
7. Power OFF the system, and revert the recovery jumper position to "normal operation".
8. Power ON the system.
9. Do NOT interrupt the BIOS POST during the first boot.

6.1.5 Reset BIOS Settings (J1D5)

The former name for this jumper is CMOS Clear. It is used to be the BIOS reset jumper. Since the previous generation, the BIOS has moved CMOS data to the NVRAM region of the BIOS flash. The BIOS checks during boot to determine if the data in the NVRAM needs to be set to default. (Same function as F9 in BIOS, loading BIOS default)

Table 57. Reset BIOS Jumper

Jumper Position	Mode of Operation	Note
1-2	Normal	Normal mode
2-3	Clear BIOS settings	BIOS settings are reset to factory default

Steps to clear BIOS settings:

1. Power down server. Do not unplug the power cord.
2. Open the server chassis. For instructions, see your server chassis documentation.
3. Move jumper (J1D5) from the default operating position, covering pins 1 and 2, to the reset/clear position, covering pins 2 and 3.
4. Wait five seconds.
5. Remove AC power.
6. Move the jumper back to default position, covering pins 1 and 2.
7. Close the server chassis.
8. Power up the server.

The BIOS settings are now cleared and you can reset it by going into the BIOS setup.

Note: Removing AC Power before performing the BIOS settings Clear operation causes the system to automatically power up and immediately power down, after the procedure is followed and AC power is re-applied. If this happens, remove the AC power cord again, wait 30 seconds, and re-install the AC power cord. Power-up the system and proceed to the <F2> BIOS Setup Utility to reset the desired settings.

7. Connector/Header Locations and Pin-out

7.1 Power Connectors

To facilitate customers who want to cable to this board from a power supply, the power connector is implemented through two 6-pin Minifit Jr* connectors, that can be used to deliver 12amps per pin or 60+Amps total. Note that no over-voltage protective circuits will exist on the board.

Table 58. Main Power Supply Connector 6-pin 2x3 Connector (J4K1 and J3K1)

Pin	Signal Name	Pin	Signal Name
1	GND	4	+12V
2	GND	5	+12V
3	GND	6	+12V

7.2 System Management Headers

7.2.1 Intel® Remote Management Module 4 (Intel® RMM4 Lite) Connector

A 7-pin Intel® RMM4 Lite connector (J1A2) is included on the server board to support the optional Intel® Remote Management Module 4. There is no support for third-party management cards on this server board.

Note: This connector is not compatible with the Intel® Remote Management Module 3 (Intel® RMM3).

Table 59. Intel® RMM4 Lite Connector Pin-out (J1A2)

Pin	Signal Description	Pin	Signal Description
1	DI	2	VCC
3	CLK	4	KEY
5	GND	6	DO
7	GND	8	CS_N

7.2.2 IPMB Header

Table 60. IPMB Header 4-pin (J2D2)

Pin	Signal Name	Description
1	SMB_IPMB_5VSB_DAT	BMC IPMB 5V standby data line
2	GND	Ground
3	SMB_IPMB_5VSB_CLK	BMC IPMB 5V standby clock line
4	P5V_STBY	+5V standby power

7.3 Bridge Board Connector

The bridge board delivers SATA/SAS signals, Disk back plane management signals, BMC SMBus*s as well as SSI-Compliant front panel and miscellaneous Node specific signals. The fifth SAS connection was added to support a Raid 5 + hot spare configuration. This drives the addition of a second set of SGPIO pins.

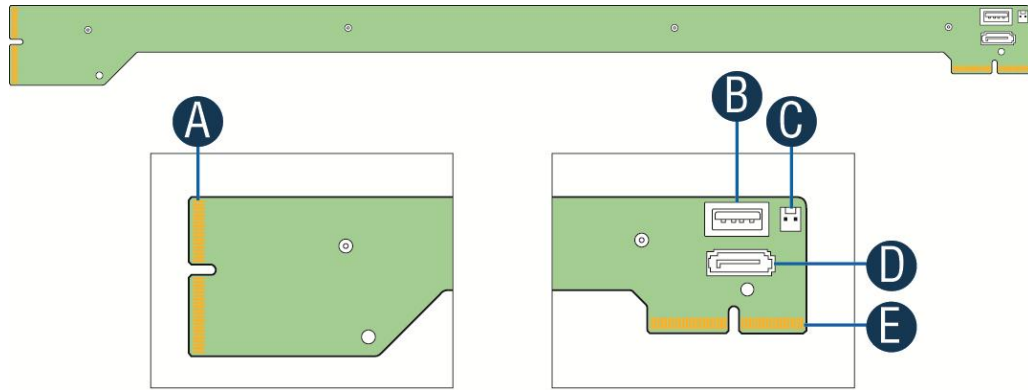

AF004431

A	2x40 pin card edge connector (to backplane)
B	USB 2.0 Type-A connector
C	2-pin 5V_AUX power
D	AHCI SATA0 DOM port connector
E	2x40 pin card edge connector (to baseboard slot)

Figure 48. Connectors on Bridge Board

Table 61. Bridge Board Connector (J1D1)

Side Even	Signal	Side Odd	Signal
80	SATA_SAS_SEL	79	GND
78	GND	77	GND
76	SAS0_RX_DP	75	SAS0_TX_DN
74	SAS0_RX_DN	73	SAS0_TX_DP
72	GND	71	GND
70	SAS1_TX_DP	69	SAS1_RX_DN
68	SAS1_TX_DN	67	SAS1_RX_DP
66	GND	65	GND
64	SAS2_RX_DP	63	SAS2_TX_DN
62	SAS2_RX_DN	61	SAS2_TX_DP
60	GND	59	GND
58	SAS3_TX_DP	57	SAS3_RX_DN
56	SAS3_TX_DN	55	SAS3_RX_DP
54	GND	53	GND
52	SGPIO_CLK	51	SPKR_IN
50	IBMC_ID0	49	SGPIO_SAS1_LOAD
48	IBMC_ID1	47	SGPIO_SAS1_DATA_OUT
46	IBMC_ID2	45	SGPIO_SAS1_DATA_IN
44	IBMC_ID3	43	PS_EN_PSU_N
42	SPA_SIN_N	41	IRQ_PMBUS Alert_N
40	SPA_SOUT_N	39	GND
38	FP NMI BTN_N	37	SMB_PMBUS_CLK

Side Even	Signal	Side Odd	Signal
36	FP PWR BTN_N	35	SMBUS_PMBUS_DATA
34	FP RST BTN_N	33	GND
32	FP ID BTN_N	31	SMB_HSBP_3V3STBY_CLK
30	FP ID LED_N	29	SMB_HSBP_3V3STBY_DATA
28	FP PWR LED_N	27	GND
26	FP STS LED G_N	25	SMB_3V3STBY_CLK
24	FP STS LED A_N	23	SMB_3V3STBY_DATA
22	FP ACT LED_N	21	GND
20	FP HDD ACT LED_N	19	IPMB-5VSTBY_Clk
18	GND	17	IPMB-5VSTBY_Data
16	USB2_P0_DN	15	GND
14	USB2_P0_DP	13	SPARE
12	GND	11	ALL_NODE_OFF
10	SATA0_RX_DP	9	GND
8	SATA0_RX_DN	7	GND
6	GND	5	SATA0_TX_DP
4	USB_OC_FP	3	SATA0_TX_DN
2	5V Aux	1	5V Aux

Combined system BIOS and the Integrated BMC support provide the functionality of the various supported control panel buttons and LEDs. The following sections describe the supported functionality of each control panel feature.

7.4 Power Button

The BIOS supports a front control panel power button. Pressing the power button initiates a request that the Integrated BMC forwards to the ACPI power state machines in the chipset. It is monitored by the Integrated BMC and does not directly control power on the power supply.

- **Power Button — Off to On**
The Integrated BMC monitors the power button and the wake-up event signals from the chipset. A transition from either source results in the Integrated BMC starting the power-up sequence. Since the processors are not executing, the BIOS does not participate in this sequence. The hardware receives the power good and reset signals from the Integrated BMC and then transitions to an ON state.
- **Power Button — On to Off (operating system absent)**
The System Control Interrupt (SCI) is masked. The BIOS sets up the power button event to generate an SMI and checks the power button status bit in the ACPI hardware registers when an SMI occurs. If the status bit is set, the BIOS sets the ACPI power state of the machine in the chipset to the OFF state. The Integrated BMC monitors power state signals from the chipset and de-asserts PS_PWR_ON to the power supply. As a safety mechanism, if the BIOS fails to service the request, the Integrated BMC automatically powers off the system in four to five seconds.
- **Power Button — On to Off (operating system present)**
If an ACPI operating system is running, pressing the power button switch generates a request through SCI to the operating system to shut down the system. The operating

system retains control of the system and the operating system policy determines the sleep state into which the system transitions, if any. Otherwise, the BIOS turns off the system.

7.5 Reset Button

The platform supports a front control panel reset button. Pressing the reset button initiates a request forwarded by the Integrated BMC to the chipset. The BIOS does not affect the behavior of the reset button.

7.6 Chassis Identify Button

The front panel Chassis Identify button toggles the state of the chassis ID LED. If the LED is off, pushing the ID button lights the LED. It remains lit until the button is pushed again or until a *Chassis Identify* or a *Chassis Identify LED* command is received to change the state of the LED.

7.7 Power LED

The green power LED is active when the system DC power is on. The power LED is controlled by the BIOS. The power LED reflects a combination of the state of system (DC) power and the system ACPI state. The following table identifies the different states that the power LED can assume.

Table 62. Power LED Indicator States

State	ACPI	Power LED
Power off	No	Off
Power on	No	Solid on
S5	Yes	Off
S1 Sleep	Yes	~1 Hz blink
S0	Yes	Solid on

7.8 System Status LED

Note: The system status LED state shows the state for the current, most severe fault. For example, if there was a critical fault due to one source and a non-critical fault due to another source, the system status LED state would be solid on (the critical fault state).

The system status LED is a bicolor LED. Green (status) shows a normal operation state or a degraded operation. Amber (fault) shows the system hardware state and overrides the green status.

The Integrated BMC-detected state and the state from the other controllers, such as the SCSI/SATA hot-swap controller state, are included in the LED state. For fault states monitored by the Integrated BMC sensors, the contribution to the LED state follows the associated sensor state, with the priority going to the most critical state currently asserted.

When the server is powered down (transitions to the DC-off state or S5), the Integrated BMC is still on standby power and retains the sensor and front panel status LED state established prior to the power-down event.

The following table maps the system state to the LED state.

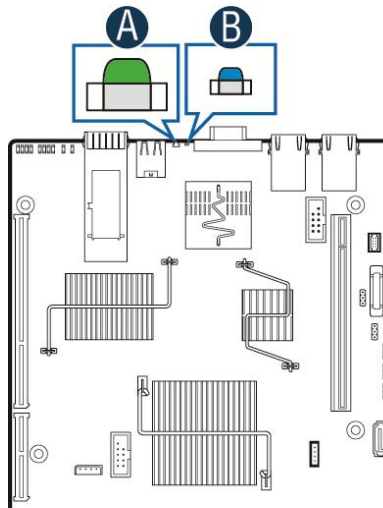

AF004832

Figure 49. System Status LED (A) and ID LED (B)

Table 63. System Status LED

Color	State	System Status	Description
Green	Solid on	OK	System ready
Green	~1 Hz blink	Degraded	<p>BIOS detected</p> <p>Unable to use all of the installed memory (more than one DIMM installed).¹</p> <p>In a mirrored configuration, when memory mirroring takes place and system loses memory redundancy. This is not covered by (2).¹</p> <p>PCI Express* correctable link errors.</p> <p>Integrated BMC detected</p> <p>Redundancy loss such as a power supply or fan. Applies only if the associated platform subsystem has redundancy capabilities.</p> <p>CPU disabled – if there are two CPUs and one CPU is disabled.</p> <p>Fan alarm – Fan failure. Number of operational fans should be more than minimum number needed to cool the system.</p> <p>Non-critical threshold crossed – Temperature, voltage, power nozzle, power gauge, and PROCHOT² (Therm Ctrl) sensors.</p> <p>Battery failure.</p> <p>Predictive failure when the system has redundant power supplies.</p>

Color	State	System Status	Description
Amber	~1 Hz blink	Non-Fatal	Non-fatal alarm – system is likely to fail: BIOS Detected In non-mirroring mode, if the threshold of ten correctable errors is crossed within the window. ¹ PCI Express* uncorrectable link errors. Integrated BMC Detected Critical threshold crossed – Voltage, temperature, power nozzle, power gauge, and PROCHOT (therm Ctrl) sensors. VRD Hot asserted. Minimum number of fans to cool the system is not present or have failed.
Amber	Solid on	Fatal	Fatal alarm – system has failed or shut down: BIOS Detected DIMM failure when there is one DIMM present and no good memory is present. ¹ Run-time memory uncorrectable error in non-redundant mode. ¹ CPU configuration error (for instance, processor stepping mismatch). Integrated BMC Detected CPU CATERR signal asserted. CPU 1 is missing. CPU THERMTRIP. No power good – power fault. Power Unit Redundancy sensor – Insufficient resources offset (indicates not enough power supplies are present).
Off	N/A	Not ready	Main power off

Notes:

1. The BIOS detects these conditions and sends a Set Fault Indication command to the Integrated BMC to provide the contribution to the system status LED.
2. Support for an upper, non-critical threshold limit is not provided in default SDR configuration. However if a user does enable this threshold in the SDR, then the system status LED should behave as described.

7.9 Chassis ID LED

The chassis ID LED provides a visual indication of a system being serviced. The state of the chassis ID LED is affected by the following:

- Toggled by the chassis ID button
- Controlled by the *Chassis Identify* command (IPMI)
- Controlled by the *Chassis Identify LED* command (OEM)

Table 64. Chassis ID LED Indicator States

State	LED State
Identify active through button	Solid on

State	LED State
Identify active through command	~1 Hz blink
Off	Off

There is no precedence or lock-out mechanism for the control sources. When a new request arrives, all previous requests are terminated. For example, if the chassis ID LED is blinking and the chassis ID button is pressed, then the chassis ID LED changes to solid on. If the button is pressed again with no intervening commands, the chassis ID LED turns off.

7.10 I/O Connectors

7.10.1 PCI Express* Connectors

The Intel® Server Board S2600WP uses four PCI Express* slots physically with different pin out definition. Each riser slot has dedicated usage and cannot be used for normal PCIe based add-in card.

- Riser Slot 1: Riser to support PCIe x16 add-in card or GPGPU card
- Riser Slot 2: Riser to support PCIe x16 add-in card, GPGPU card or Intel® IOM card
- Riser Slot 3 and 4: Risers to support PCIe x16 add-in cards or GPGPU cards (Intel® server system H2000WP does not support risers for slot 3 and slot 4.)

The pin-outs for the slots are shown in the following tables.

Table 65. PCI Express* x16 IO Riser Slot 1 Connector (J6A1)

Pin	Pin Name	Description	Pin	Pin Name	Description
B1	12V	20W 3.3V generated on riser	A1	12V	20W 3.3V generated on riser
B2	12V	66W for GPU	A2	12V	66W for GPU
B3	12V	66W for GPU	A3	12V	66W for GPU
B4	12V	66W for GPU	A4	SMDATA	
B5	SMCLK		A5	3.3VAUX	For wake on LAN
B6	3.3VAUX	For wake on LAN	A6	GPU_NODE_ON	can turn of 2U GPU power
B7	GND		A7	GPU_PWRGD	
B8	Tach9		A8	Tach11	
B9	Tach8		A9	Tach10	
B10	Tach7		A10	Tach6	
B11	Spare		A11	Spare	
KEY					
B12	Spare		A12	PWM2	GPU Fan speed control
B13	Spare		A13	GND	
B14	GND		A14	PERST#	
B15	SMBUS_R4_CLK		A15	WAKE#	
B16	SMBUS_R4_DAT		A16	GND	

Pin	Pin Name	Description	Pin	Pin Name	Description
B17	GND		A17	REFCLK+	Clock pair 1
B18	PETxP0	Tx Lane 0+	A18	REFCLK-	Clock pair 1
B19	PETxN0	Tx Lane 0-	A19	GND	
B20	GND		A20	PERxP0	Rx Lane 0+
B21	GND		A21	PERxN0	Rx Lane 0-
B22	PETxP1	Tx Lane 1+	A22	GND	
B23	PETxN1	Tx Lane 1-	A23	GND	
B24	GND		A24	PERxP1	Rx Lane 1+
B25	GND		A25	PERxN1	Rx Lane 1-
B26	PETxP2	Tx Lane 2+	A26	GND	
B27	PETxN2	Tx Lane 2-	A27	GND	
B28	GND		A28	PERxP2	Rx Lane 2+
B29	GND		A29	PERxN2	Rx Lane 2-
B30	PETxP3	Tx Lane 3+	A30	GND	
B31	PETxN3	Tx Lane 3-	A31	GND	
B32	GND		A32	PERxP3	Rx Lane 3+
B33	GND		A33	PERxN3	Rx Lane 3-
B34	PETxP4	Tx Lane 4+	A34	GND	
B35	PETxN4	Tx Lane 4-	A35	GND	
B36	GND		A36	PERxP4	Rx Lane 4+
B37	GND		A37	PERxN4	Rx Lane 4-
B38	PETxP5	Tx Lane 5+	A38	GND	
B39	PETxN5	Tx Lane 5-	A39	GND	
B40	GND		A40	PERxP5	Rx Lane 5+
B41	GND		A41	PERxN5	Rx Lane 5-
B42	PETxP6	Tx Lane 6+	A42	GND	
B43	PETxN6	Tx Lane 6-	A43	GND	
B44	GND		A44	PERxP6	Rx Lane 6+
B45	GND		A45	PERxN6	Rx Lane 6-
B46	PETxP7	Tx Lane 7+	A46	GND	
B47	PETxN7	Tx Lane 7-	A47	GND	
B48	GND		A48	PERxP7	Rx Lane 7+
B49	GND		A49	PERxN7	Rx Lane 7-
B50	PETxP8	Tx Lane 8+	A50	GND	
B51	PETxN8	Tx Lane 8-	A51	GND	
B52	GND		A52	PERxP8	Rx Lane 8+
B53	GND		A53	PERxN8	Rx Lane 8-
B54	PETxP9	Tx Lane 9+	A54	GND	
B55	PETxN9	Tx Lane 9-	A55	GND	
B56	GND		A56	PERxP9	Rx Lane 9+
B57	GND		A57	PERxN9	Rx Lane 9-
B58	PETxP10	Tx Lane 10+	A58	GND	
B59	PETxN10	Tx Lane 10-	A59	GND	

Pin	Pin Name	Description	Pin	Pin Name	Description
	0				
B60	GND		A60	PERxP10	Rx Lane 10+
B61	GND		A61	PERxN10	Rx Lane 10-
B62	PETxP1 1	Tx Lane 11+	A62	GND	
B63	PETxN1 1	Tx Lane 11-	A63	GND	
B64	GND		A64	PERxP11	Rx Lane 11+
B65	GND		A65	PERxN11	Rx Lane 11-
B66	PETxP1 2	Tx Lane 12+	A66	GND	
B67	PETxN1 2	Tx Lane 12-	A67	GND	
B68	GND		A68	PERxP12	Rx Lane 12+
B69	GND		A69	PERxN12	Rx Lane 12-
B70	PETxP1 3	Tx Lane 13+	A70	GND	
B71	PETxN1 3	Tx Lane 13-	A71	GND	
B72	GND		A72	PERxP13	Rx Lane 13+
B73	GND		A73	PERxN13	Rx Lane 13-
B74	PETxP1 4	Tx Lane 14+	A74	GND	
B75	PETxN1 4	Tx Lane 14-	A75	GND	
B76	GND		A76	PERxP14	Rx Lane 14+
B77	REFCLK +	Clock pair 2	A77	PERxN14	Rx Lane 14-
B78	REFCLK -	Clock pair 2	A78	GND	
B79	GND		A79	PERxP15	Rx Lane 15+
B80	PETxP1 5	Tx Lane 15+	A80	PERxN15	Rx Lane 15-
B81	PETxN1 5	Tx Lane 15-	A81	GND	
B82	GND		A82	Riser ID	

Table 66. PCI Express* x16 Riser Slot 2 Connector (J1B2)

Side Even	Signal	Description	Side Odd	Signal	Description
200	12V	20W 3.3V generated on riser	199	12V	for IOM
198	12V	66W for GPU	197	12V	66W for GPU
196	12V	66W for GPU	195	spare	
194	spare		193	spare	
192	spare		191	GND	
190	spare		189	SMDATA	for rIOM temp sensor
188	GND		187	5VAUX	For DNM and IOM wake

Side Even	Signal	Description	Side Odd	Signal	Description
					on LAN
186	SMCLK	for rIOM temp sensor	185	PRESENT#	rIOM function present
184	3.3V Aux	For DNM and IOM wake on LAN	183	RIOM_ACT#	
182	GND		181	RXD_3	RGMII receive data
180	TXD_0	RGMII txmit data	179	RXD_2	RGMII receive data
178	TXD_1	RGMII txmit data	177	RXD_1	RGMII receive data
176	TXD_2	RGMII txmit data	175	RXD_0	RGMII receive data
174	TXD_3	RGMII txmit data	173	GND	
172	GND		171	RX_CTL	RGMII receive Cntrl
170	TX_CLK	RGMII txmit Clock	169	GND	
168	TX_CTL	RGMII txmit Cntrl	167	RX_CLK	RGMII receive Clock
166	MDIO		165	MDC	
164	spare		163	GND	
162	GND		161	IB_CLK3+	
160	PERST#		159	IB_CLK3-	
158	WAKE#		157	GND	
156	GND		155	CLK1+	
154	CLK2+		153	CLK1-	
152	CLK2-		151	GND	
150	GND		149	R00+	
148	T00+		147	R00-	
146	T00-		145	GND	
144	GND		143	R01+	
142	T01+		141	R01-	
140	T01-		139	GND	
138	GND		137	R02+	
136	T02+		135	R02-	
134	T02-		133	GND	
132	GND		131	R03+	
130	T03+		129	R03-	
128	T03-		127	GND	
126	GND		125	R04+	
124	T04+		123	R04-	
122	T04-		121	GND	
120	GND		119	R05+	
118	T05+		117	R05-	
116	T05-		115	GND	
114	GND		113	R06+	
112	T06+		111	R06-	
110	T06-		109	GND	
108	GND		107	R07+	
106	T07+		105	R07-	
104	T07-		103	GND	
102	GND		101	IB_R00+	
100	IB_T00+		99	IB_R00-	
98	IB_T00-		97	GND	
96	GND		95	IB_R01+	
94	IB_T01+		93	IB_R01-	
92	IB_T01-		91	GND	
90	GND		89	IB_R02+	
88	IB_T02+		87	IB_R02-	

Side Even	Signal	Description	Side Odd	Signal	Description
86	IB_T02-		85	GND	
84	GND		83	IB_R03+	
82	IB_T03+		81	IB_R03-	
80	IB_T03-		79	GND	
78	GND		77	IB_R04+	
76	IB_T04+		75	IB_R04-	
74	IB_T04-		73	GND	
72	GND		71	IB_R05+	
70	IB_T05+		69	IB_R05-	
68	IB_T05-		67	GND	
66	GND		65	GND	
64	GND		63	GND	
62	GND		61	IB_R06+	
60	IB_T06+		59	IB_R06-	
58	IB_T06-		57	GND	
56	GND		55	IB_R07+	
54	IB_T07+		53	IB_R07-	
52	IB_T07-		51	GND	
50	GND		49	R08+	
48	T08+		47	R08-	
46	T08-		45	GND	
44	GND		43	R09+	
42	T09+		41	R09-	
40	T09-		39	GND	
38	GND		37	R10+	
36	T10+		35	R10-	
34	T10-		33	GND	
32	GND		31	R11+	
30	T11+		29	R11-	
28	T11-		27	GND	
26	GND		25	R12+	
24	T12+		23	R12-	
22	T12-		21	GND	
20	GND		19	R13+	
18	T13+		17	R13-	
16	T13-		15	GND	
14	GND		13	R14+	
12	T14+		11	R14-	
10	T14-		9	GND	
8	GND		7	R15+	
6	T15+		5	R15-	
4	T15-		3	GND	
2	GND		1	Riser ID	Riser ID

Table 67. PCI Express* x16 Riser Slot 3 Connector (J1F1)

Side even	Signal	Side Odd	Signal
120	12V	119	SMBUS
118	12V	117	SMBUS
116	12V	115	GND

Side even	Signal	Side Odd	Signal
114	3.3V Aux	113	CLK2+
112	GND	111	CLK2-
110	PERST#	109	GND
108	WAKE#	107	CLK1+
106	spare	105	CLK1-
104	spare	103	GND
102	gnd	101	R00+
100	T00+	99	R00-
98	T00-	97	GND
96	GND	95	R01+
94	T01+	93	R01-
92	T01-	91	GND
90	GND	89	R02+
88	T02+	87	R02-
86	T02-	85	GND
84	GND	83	R03+
82	T03+	81	R03-
80	T03-	79	GND
78	GND	77	R04+
76	T04+	75	R04-
74	T04-	73	GND
72	GND	71	R05+
70	T05+	69	R05-
68	T05-	67	GND
66	GND	65	spare
64	spare	63	GND
62	GND	61	R06+
60	T06+	59	R06-
58	T06-	57	GND
56	GND	55	R07+
54	T07+	53	R07-
52	T07-	51	GND
50	GND	49	R08+
48	T08+	47	R08-
46	T08-	45	GND
44	GND	43	R09+
42	T09+	41	R09-
40	T09-	39	GND
38	GND	37	R10+
36	T10+	35	R10-
34	T10-	33	GND
32	GND	31	R11+
30	T11+	29	R11-

Side even	Signal	Side Odd	Signal
28	T11-	27	GND
26	GND	25	R12+
24	T12+	23	R12-
22	T12-	21	GND
20	GND	19	R13+
18	T13+	17	R13-
16	T13-	15	GND
14	GND	13	R14+
12	T14+	11	R14-
10	T14-	9	GND
8	GND	7	R15+
6	T15+	5	R15-
4	T15-	3	GND
2	GND	1	Riser ID

Table 68. PCI Express* x16 Riser Slot 4 Connector (J1H1)

Pin	PCle	Description	Pin	Riser	Description
B1	SMCLK	MA1	SMDATA	M	
B2	3.3VAUX	For wake on LAN	A2	3.3VAUX	For wake on LAN
B3	GND	NA3	GND	N	
B4	REFCLK+	Clock pair 2	A4	REFCLK+	Clock pair 1
B5	REFCLK-	Clock pair 2	A5	REFCLK-	Clock pair 1
B6	GND	NA6	GND	N	
B7	PERST#	EA7	ID	I	
B8	WAKE#	AA8	8KE		
B9			A9		
B10			A10		
B11			A11		
B12	GND	NA12	GND	N	
B13	PETxP0	Tx Lane 0+	A13	PERxP0	Rx Lane 0+
B14	PETxN0	Tx Lane 0-	A14	PERxN0	Rx Lane 0-
B15	GND	NA15	GND	N	
B16	PETxP1	Tx Lane 1+	A16	PERxP1	Rx Lane 1+
B17	PETxN1	Tx Lane 1-	A17	PERxN1	Rx Lane 1-
B18	GND	NA18	GND	N	
B19	PETxP2	Tx Lane 2+	A19	PERxP2	Rx Lane 2+
B20	PETxN2	Tx Lane 2-	A20	PERxN2	Rx Lane 2-
B21	GND	NA21	GND	N	
B22	PETxP3	Tx Lane 3+	A22	PERxP3	Rx Lane 3+
B23	PETxN3	Tx Lane 3-	A23	PERxN3	Rx Lane 3-

Pin	PCIe	Description	Pin	Riser	Description
B24	GND	NA24	GND	N	
B25	PETxP4	Tx Lane 4+	A25	PERxP4	Rx Lane 4+
B26	PETxN4	Tx Lane 4-	A26	PERxN4	Rx Lane 4-
B27	GND	NA27	GND	N	
B28	PETxP5	Tx Lane 5+	A28	PERxP5	Rx Lane 5+
B29	PETxN5	Tx Lane 5-	A29	PERxN5	Rx Lane 5-
B30	GND	NA30	GND	N	
B31	PETxP6	Tx Lane 6+	A31	PERxP6	Rx Lane 6+
B32	PETxN6	Tx Lane 6-	A32	PERxN6	Rx Lane 6-
B33	GND	NA33	GND	N	
B34	PETxP7	Tx Lane 7+	A34	PERxP7	Rx Lane 7+
B35	PETxN7	Tx Lane 7-	A35	PERxN7	Rx Lane 7-
B36	GND	NA36	GND	N	
B37	PETxP8	Tx Lane 8+	A37	PERxP8	Rx Lane 8+
B38	PETxN8	Tx Lane 8-	A38	PERxN8	Rx Lane 8-
B39	GND	NA39	GND	N	
B40	PETxP9	Tx Lane 9+	A40	PERxP9	Rx Lane 9+
B41	PETxN9	Tx Lane 9-	A41	PERxN9	Rx Lane 9-
B42	GND	NA42	GND	N	
B43	PETxP10	Tx Lane 10+	A43	PERxP10	Rx Lane 10+
B44	PETxN10	Tx Lane 10-	A44	PERxN10	Rx Lane 10-
B45	GND	NA45	GND	N	
B46	PETxP11	Tx Lane 11+	A46	PERxP11	Rx Lane 11+

Pin	PCIe	Description	Pin	Riser	Description
B47	PETxN11	Tx Lane 11-	A47	PERxN11	Rx Lane 11-
B48	GND	NA48	GND	N	
B49	PETxP12	Tx Lane 12+	A49	PERxP12	Rx Lane 12+
B50	PETxN12	Tx Lane 12-	A50	PERxN12	Rx Lane 12-
B51	GND	NA51	GND	N	
B52	PETxP13	Tx Lane 13+	A52	PERxP13	Rx Lane 13+
B53	PETxN13	Tx Lane 13-	A53	PERxN13	Rx Lane 13-
B54	GND	NA54	GND	N	
B55	PETxP14	Tx Lane 14+	A55	PERxP14	Rx Lane 14+
B56	PETxN14	Tx Lane 14-	A56	PERxN14	Rx Lane 14-
B57	GND	NA57	GND	N	
B58	PETxP15	Tx Lane 15+	A58	PERxP15	Rx Lane 15+
B59	PETxN15	Tx Lane 15-	A59	PERxN15	Rx Lane 15-
B60	GND	NA60	GND	N	

Table 69. PCI Express* Riser ID Assignment

Description	CPU1		CPU2	
	Riser ID (0)	Riser ID (1)	Riser ID (2)	Riser ID (3)
Riser 1 1x16	1			
Riser 1 2x8	0			
Riser 2 1x16		1		
Riser 2 2x8		0		
Riser 3 1x16			1	
Riser 3 2x8			0	
Riser 4 1x16				1
Riser 4 2x8				0

Note:

To S2600WP Riser 2 slot, there's one discrete x8 lane. The Riser in this lane is independent from this Riser ID assignment.

7.10.2 VGA Connector

The following table details the pin-out definition of the external VGA connector (J4A1).

Table 70. VGA External Video Connector (J4A1)

Pin	Signal Name	Description
1	V_IO_R_CONN	Red (analog color signal R)
2	V_IO_G_CONN	Green (analog color signal G)
3	V_IO_B_CONN	Blue (analog color signal B)
4	TP_VID_CONN_B4	No connection
5	GND	Ground
6	GND	Ground
7	GND	Ground
8	GND	Ground
9	TP_VID_CONN_B9	No connection
10	GND	Ground
11	TP_VID_CONN_B11	No connection
12	V_IO_DDCDAT	DDCDAT
13	V_IO_HSYNC_CONN	HSYNC (horizontal sync)
14	V_IO_VSYNC_CONN	VSYNC (vertical sync)
15	V_IO_DDCCLK	DDCCLK

7.10.3 NIC Connectors

The server board provides two independent RJ-45 connectors on the back edge of the board (JA6A1, JA5A1). The pin-out for NIC connectors are identical and are defined in the following table:

Table 71. RJ-45 10/100/1000 NIC Connector Pin-out (JA6A1, JA5A1)

Pin	Signal Name
1	GND
2	P1V8_NIC
3	NIC_A_MDI3P
4	NIC_A_MDI3N
5	NIC_A_MDI2P
6	NIC_A_MDI2N
7	NIC_A_MDI1P
8	NIC_A_MDI1N
9	NIC_A_MDI0P
10	NIC_A_MDI0N
11 (D1)	NIC_LINKA_1000_N (LED)
12 (D2)	NIC_LINKA_100_N (LED)
13 (D3)	NIC_ACT_LED_N
14	NIC_LINK_LED_N
15	GND
16	GND

7.10.4 SATA Connectors

The server board provides one SATA port connector named SATA-1 port (J6D1) on board. Additional four SAS ports are provided through bridge board.

The pin configuration for each connector is identical and defined in the following table:

Table 72. SATA Connector

Pin	Signal Name	Description
1	GND	Ground
2	SATA_TX_P	Positive side of transmit differential pair
3	SATA_TX_N	Negative side of transmit differential pair
4	GND	Ground
5	SATA_RX_N	Negative side of receive differential pair
6	SATA_RX_P	Positive side of receive differential pair
7	P5V_SATA/GND	+5V for DOM or Ground for SATA signals

Note: SATA DOM requires external power cannot be used with SATA-1 port.

7.10.5 Hard Drive Activity (Input) LED Header

Table 73. SATA HDD Activity (Input) LED Header (J6C5)

Pin	Description
1	LED_HD_ACTIVE_L
2	NC

7.10.6 Storage Upgrade Key Connector

The server board provides one SATA/SAS storage upgrade key connector (J6C4) on board. The Storage Upgrade Key is a small PCB board that has up to two security EEPROMs that are read by the system ME to enable different versions of LSI RAID 5 software stack and/or upgrade from SATA to SAS storage functionality.

The pin configuration of connector is identical and defined in the following table.

Table 74. Storage Upgrade Key Connector (J6C4)

Pin	Signal Description
1	GND
2	DYN_SKU_KEY
3	GND
4	SAS_SATA_RAID_KEY

7.10.7 Serial Port Connectors

The server board provides one internal 9-pin serial A header (J6A2). The following tables define the pin-outs.

Table 75. Internal 9-pin Serial A (COM1) (J6A2)

Pin	Signal Name	Pin	Signal Name
1	SPB_DCD	2	SPB_DSR
3	SPB_SIN_N	4	SPB_RTS
5	SPB_SOUT_N	6	SPB_CTS
7	SPB_DTR	8	SPB_RI
9	GND		

7.10.8 USB Connectors

The following table details the pin-out of the external stack USB port 0/1 connectors (J3A1) found on the back edge of the server board.

Table 76. External USB port Connector (J3A1)

Pin	Signal Name	Description
1	+5V	USB Power
2	USB_N	Differential data line paired with DATAH0
3	USB_P	Differential data line paired with DATA0
4	GND	Ground

One 2x5 connector on the server board provide an option to support two additional internal USB port (USB 2/3). The pin-out is detailed in the following table:

Table 77. Internal USB Connector (J2D1)

Pin	Signal Name	Pin	Signal Name
1	+5V	2	+5V
3	USB_N	4	USB_N
5	USB_P	6	USB_P
7	GND	8	GND
9	Key Pin	10	NC

7.10.9 QSFP for InfiniBand*

The following table details the pin-out of the QSFP connector (J2B1) found on the back edge of the server board. This port is only available on board SKU **S2600WPQ** and **S2600WPF**.

Table 78. QSFP Pin Definition

Side A	Signal	Side B	Signal
1	GND	1	GND
2	IB_RX0_DN0	2	IB_RX0_DN1
3	IB_RX0_DP0	3	IB_RX0_DP1
4	GND	4	GND
5	IB_RX0_DN2	5	IB_RX0_DN3
6	IB_RX0_DP2	6	IB_RX0_DP3
7	GND	7	GND
8	SMB_IB_QSFP0_DATA	8	QSFP0_MODPRSL_N
9	SMB_IB_QSFP0_CLK	9	IRQ_QSFP0_N
10	P3V3_RX_PORT0	10	P3V3_TX_PORT0
11	RST_QSFP0_N	11	P3V3_PORT0
12	FM_QSFP0_MODSEIL_N	12	QSFP0_LPMODE
13	GND	13	GND
14	IB_TX0_DP3	14	IB_TX0_DP2
15	IB_TX0_DN3	15	IB_TX0_DN2
16	GND	16	GND
17	IB_TX0_DP1	17	IB_TX0_DP0
18	IB_TX0_DN1	18	IB_TX0_DN0

Side A	Signal	Side B	Signal
19	GND	19	GND

7.11 Fan Headers

To facilitate the connection of 3 x40mm double rotor fans, a 14 pin header is provided, all fans will share a PWM. Both rotor tachs can be monitored.

Table 79. Baseboard Fan Connector (J1K2)

Pin	Signal Name	Pin	Signal Name
1	PWM1	2	Reserved
3	Tach0	4	Tach1
5	Tach2	6	Tach3
7	Tach4	8	Tach5
9	NODE_ON	10	GND
11	SMBUS_R4 CLK	12	SMBUS_R4 DAT
13	NODE_ADR0	14	NODE_PWRGD

The SMBus* is used to connect to the hot swap controller that provides inrush current protection and can measure the power being used by the node. The NODE_ON signal is used to turn on the hot swap controller. Note that the polarity is correct as the ADI1275 controller uses a high true enable signal. When the node is turned off, the fans will continue to rotate at a preset rate; this rate is selected by Intel® and preset by the Fan manufacturer. This is done to stop air recirculation between nodes. When docking the board to a live 12V rail, the fans could spin up immediately; it may be required to phase their connection to power to minimize the inrush current. Bench testing of the fans should determine if this is necessary.

7.12 Chassis Intrusion

The Chassis Intrusion header is connected through a two-wire cable to a switch assembly that is mounted just under the chassis cover on systems that support this feature. When the chassis cover is removed, the switch and thus the electrical connection between the pins on this header become open allowing the Server Engines PILOT III BMC's CHASIS_N pin to be pulled LOW. The Server Engines PILOT III BMC's CHASIS_N pin is used by Firmware to note the change in the chassis cover status. Header on baseboard can be unstuffed by default a shorting resistor will be needed to close the circuit.

Table 80. Chassis Intrusion Header (J6C1)

Header state	Description
PINS 1 and 2 CLOSED	BMC CHASIS_N is pulled HIGH. Chassis cover is closed.
PINS 1 and 2 OPEN	BMC CHASIS_N is pulled LOW. Chassis cover is removed.

Note:

Intel® Server System H2000WP's chassis and Intel® Server Board S2600WP, S2600WPQ, and S2600WPF's firmware do not support Chassis Intrusion.

8. Intel® Light-Guided Diagnostics

Intel® Server Board S2600WP has several onboard diagnostic LEDs to assist in troubleshooting board-level issues. This section provides a description the location and function of each LED on the server board.

8.1 Front Panel Support

The Intel® Server Board S2600WP supports Mini-FP on Intel® Server Chassis H2000WP. The front panel control signals are provided through bridge board.

Each Mini-FP provides the below switch and LED features:

- Power switch with integrated power LED (green), includes clear button lens but painted black with laser etched power icon for light to shine through
- Chassis ID switch with integrated ID LED (blue), includes clear button lens but painted black with laser etched ID icon for light to shine through
- Recessed reset switch with black actuator
- Bi-color Status/Fault LED (green/amber). Includes a status/fault icon printed on cosmetic front panel label. Icon should be translucent (only shows when LED is on).
- Single network activity/link LED, hardware baseboard ORs Ethernet and InfiniBand* activity signals together into just one global signal. Includes a network activity/link icon printed on cosmetic front panel label. Icon is translucent (only shows when LED is on).

8.1.1 System ID LED

The server board supports a blue system ID LED on the front panel, which is used to visually identify a specific server installed among many other similar servers. There are two options available for illuminating the System ID LED.

1. The front panel ID LED Button is pushed, which causes the LED to illuminate to a solid on state until the button is pushed again.
2. An IPMI “Chassis Identify” command is remotely entered, which causes the LED to blink

The System ID LED on the server board is tied directly to the System ID LED on system front panel if present.

8.1.2 System Status LED

The server board supports status LED on the front panel, which acts as same as the status LED on the server board.

8.1.3 Network Link/Activity LED

The server board provides LED on the front panel for Network Link/Activity. On **S2600WP** base SKU, this LED shows the status of Ethernet port. On **S2600WPQ and S2600WPF**, this LED still shows the Ethernet port link and activities. Below table shows the LED detail.

Table 81. Network link/activity LED

LED	Color	Condition	What It Means
LAN - Link/Activity	Green	On	LAN link/no access
	Green	Blink	LAN access
		Off	Idle

8.1.4 Dedicated InfiniBand* Link/Activity LED

The server board provides dedicated LEDs for InfiniBand* Link/Activity. They are located on the baseboard rear, near diagnostic LED set. This set of LEDs only works on **S2600WPQ** baseboard. See block B in Figure 50 for the location of LEDs.

Below table shows the LED details:

Table 82. InfiniBand* link/activity LED

LED Color	LED State	NIC State
Amber (Right)	Off	No Logical Link
	Blinking	Logical Link established
Green (Left)	Off	No Physical Link
	On	Physical Link established

8.2 POST Code Diagnostic LEDs

Eight amber POST code diagnostic LEDs are located on the back left edge of the server board in the rear I/O area of the server board by the QSFP connector.

During the system boot process, the BIOS executes a number of platform configuration processes, each of which is assigned a specific hex POST code number. As each configuration routine is started, the BIOS displays the given POST code to the POST code diagnostic LEDs on the back edge of the server board. To assist in troubleshooting a system hang during the POST process, you can use the Diagnostic LEDs to identify the last POST process executed. For a complete description of how these LEDs are read and a list of all supported POST codes, refer to Appendix A. (Appendix B refers to InfiniBand* LEDs for Link and activity status.)

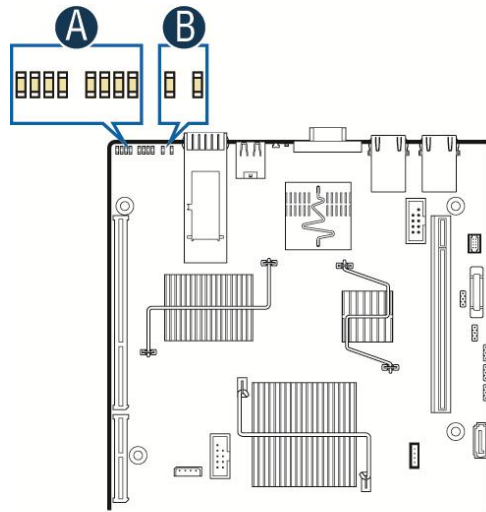

AF004833

Figure 50. Rear Panel Diagnostic LEDs (Block A)

9. Environmental Limits Specification

Operation of the server board at conditions beyond those shown in the following table may cause permanent damage to the system. Exposure to absolute maximum rating conditions for extended periods may affect long term system reliability.

Table 83. Server Board Design Specifications

Operating Temperature	0° C to 55° C (32° F to 131° F) at product airflow specification
Non-Operating Temperature	-40° C to 70° C (-40° F to 158° F)
DC Voltage	± 5% of all nominal voltages
Shock (Unpackaged)	Trapezoidal, 35g , 170 inches/sec
Shock (Packaged)	
<20 pounds	36 inches
>= 20 to <40 pounds	30 inches
>= 40 to <80 pounds	24 inches
>= 80 to <100 pounds	18 inches
>= 100 to <120 pounds	12 inches
>= 120 pounds	9 inches
Vibration (Unpackaged)	5 Hz to 500 Hz 3.13 g RMS random

Notes:

1. Intel Corporation server boards contain a number of high-density VLSI and power delivery components that need adequate airflow to cool. Intel® ensures through its own chassis development and testing that when Intel® server building blocks are used together, the fully integrated system will meet the intended thermal requirements of these components. It is the responsibility of the system integrator who chooses not to use Intel® developed server building blocks to consult vendor datasheets and operating parameters to determine the amount of airflow required for their specific application and environmental conditions. Intel Corporation cannot be held responsible, if components fail or the server board does not operate correctly when used outside any of its published operating or non-operating limits.
2. The Energy Star compliance is at systems level not board level. Use of Intel® boards alone does not guarantee Energy Star compliance.
3. Chassis design must provide proper airflow to avoid exceeding the Intel® Xeon® processor maximum case temperature.

Disclaimer Note: Intel® ensures the unpackaged server board and system meet the shock requirement mentioned above through its own chassis development and system configuration. It is the responsibility of the system integrator to determine the proper shock level of the board and system if the system integrator chooses different system configuration or different chassis. Intel Corporation cannot be held responsible if components fail or the server board does not operate correctly when used outside any of its published operating or non-operating limits.

9.1 System Level Environmental Considerations

In order to maintain comprehensive thermal protection, deliver the best system acoustics, and fan power efficiency, an intelligent Fan Speed Control (FSC) and thermal management technology (mechanism) is used. Options in <F2> BIOS Setup (BIOS>Advanced>System Acoustic and Performance Configuration) allow for parameter adjustments based on the actual system configuration and usage. Refer to the following sections for a description of each setting.

9.1.1 Set Throttling Mode

This option is used to select the desired memory thermal throttling mechanism. Available settings include:

- **[Auto]** – Factory Default Setting - BIOS automatically detects and identifies the appropriate thermal throttling mechanism based on DIMM type, airflow input, and DIMM sensor availability.
- **[DCLTT]** – Dynamic Closed Loop Thermal Throttling: for the SOD DIMM with system airflow input
- **[SCLTT]** – Static Close Loop Thermal Throttling: for the SOD DIMM without system airflow input
- **[SOLTT]** – Static Open Loop Thermal Throttling: for the DIMMs without sensor on DIMM (SOD)

9.1.2 Altitude

This option is used to select the proper altitude that the system will be used in. Available settings include: [300m or less], **[301m-900m]**, [901m-1500m], [Above 1500m].

Selecting an altitude range that is lower than the actual altitude the system will be operating at, can cause the fan control system to operate less efficiently, leading to higher system thermals and lower system performance. If the altitude range selected is higher than the actual altitude the system will be operating at, the fan control system may provide better cooling but with higher acoustics and higher fan power consumption. If the altitude is not known, selecting a higher altitude is recommended in order to provide sufficient cooling.

9.1.3 Set Fan Profile

This option is used to set the desired Fan Profile. Available settings include: **[Performance]** and [Acoustic].

The Acoustic mode offers the best acoustic experience and appropriate cooling capability covering the mainstream and the majority of the add-in cards used. Performance mode is designed to provide sufficient cooling capability covering all kinds of add-in cards on the market.

9.1.4 Fan PWM Offset

This option is reserved for manual adjustment to the minimum fan speed curves. The valid range is from **[0 to 100]** which stands for 0% to 100% PWM adding to the minimum fan speed. This feature is valid when Quiet Fan Idle Mode is at Enabled state. The default setting is **[0]**

9.1.5 Quiet Fan Idle Mode

This feature can be [Enabled] or **[Disabled]**. If enabled, the fans will either shift to a lower speed or stop when the aggregate sensor temperatures are satisfied, indicating the system is at ideal thermal/light loading conditions. When the aggregate sensor temperatures are not satisfied, the fans will shift back to normal control curves. If disabled, the fans will never shift into lower fan speeds or stop, regardless of whether the aggregate sensor temperatures are satisfied or not. The default setting is [Disabled]

Note: The above feature may or may not be in effect and depends on the actual thermal characteristics of the specified system.

9.1.6 Thermal Sensor Input for Fan Speed Control

The BMC uses various IPMI sensors as inputs to fan speed control. Some of the sensors are actual physical sensors and some are “virtual” sensors derived from calculations.

The following IPMI thermal sensors are used as input to fan speed control:

- Front Panel Temperature Sensor¹
- Server board Temperature Sensor²
- Processor Margin Sensors^{3,5,6}
- DIMM Thermal Margin Sensors^{3,5}
- Exit Air Temperature Sensor^{1, 4, 8}
- Chipset Temperature Sensor^{4,6}
- On-board Ethernet Controller Temperature Sensors^{4, 6}
- Add-In Intel SAS/IO Module Temperature Sensors^{4, 6}
- Power Supply Thermal Sensor^{4,9}
- Processor VR Temperature Sensors^{4, 7}
- DIMM VR Temperature Sensors^{4, 7}
- BMC Temperature Sensor^{4, 7}
- Global Aggregate Thermal Margin Sensors⁸

Notes:

1. For fan speed control in Intel chassis
2. For fan speed control in 3rd party chassis
3. Temperature margin from throttling threshold
4. Absolute temperature
5. PECI value or margin value
6. On-die sensor
7. On-board sensor
8. Virtual sensor
9. Available only when PSU has PMBus*

The following diagram illustrates the fan speed control structure:

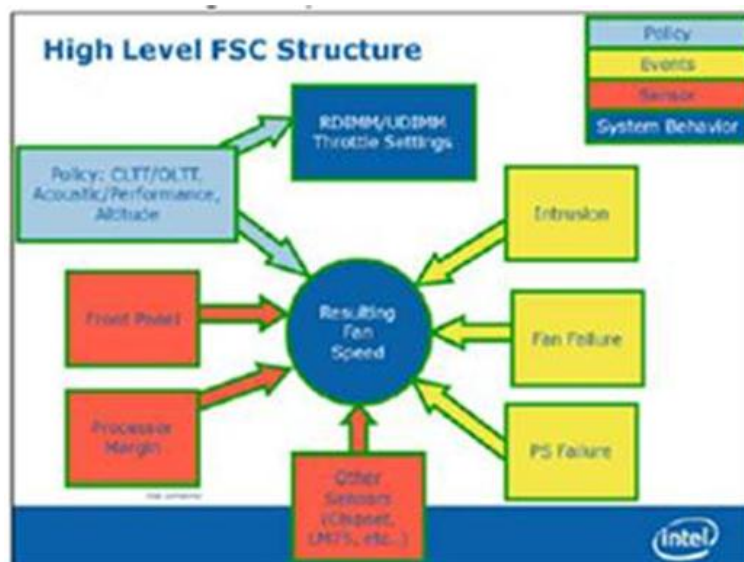

Figure 51. Fan Speed Control Structure

9.2 Processor Thermal Design Power (TDP) Support

To allow optimal operation and long-term reliability of Intel® processor-based systems, the processor must remain within the defined minimum and maximum case temperature (TCASE) specifications. Thermal solutions not designed to provide sufficient thermal capability may affect the long-term reliability of the processor and system. The server board is designed to support the Intel® Xeon® Processor E5-2600 product family TDP guidelines up to and including 135W.

Disclaimer Note: Intel Corporation server boards contain a number of high-density VLSI and power delivery components that need adequate airflow to cool. Intel® ensures through its own chassis development and testing that when Intel® server building blocks are used together, the fully integrated system will meet the intended thermal requirements of these components. It is the responsibility of the system integrator who chooses not to use Intel® developed server building blocks to consult vendor datasheets and operating parameters to determine the amount of airflow required for their specific application and environmental conditions. Intel Corporation cannot be held responsible, if components fail or the server board does not operate correctly when used outside any of their published operating or non-operating limits.

10. Power Supply Specification Guidelines

This section provides power supply specification guidelines recommended for providing the specified server platform with stable operating power requirements.

Note: The power supply data provided in this section is for reference purposes only. It reflects Intel®'s own DC power out requirements for a 1200W and 1600W power supply as used in an Intel® designed 2U server platform. The intent of this section is to provide customers with a guide to assist in defining and/or selecting a power supply for custom server platform designs that utilize the server boards detailed in this document.

10.1 Power Supply DC Output Connector

The server board includes two main power Minifit Jr connectors allowing for power supplies to attach directly to the server board. The connectors are two sets of 2x3 pin and can be used to deliver 12amps per pin or 60+Amps total. Note that no over-voltage protective circuits will exist on the board.

Table 84. Power Supply DC Power Output Connector Pinout

Pin	Signal Name	Pin	Signal Name
1	+12V	4	GND
2	+12V	5	GND
3	+12V	6	GND

10.2 Power Supply DC Output Specification

10.2.1 Output Power/Currents

The following tables define the minimum power and current ratings. The power supply must meet both static and dynamic voltage regulation requirements for all conditions.

Table 85. Minimum Load Ratings

Parameter	Min	Max.	Peak 1,2	Unit
12V main	0.0	60.0	72.0	A
5Vstby	0.0	2.0	2.4	A

Notes:

1. Peak combined power for all outputs shall not exceed 800W.
2. Length of time peak power can be supported is based on thermal sensor and assertion of the SMBAlert# signal. Minimum peak power duration shall be 20 seconds without asserting the SMBAlert# signal at maximum operating temperature.

10.2.2 Standby Output

The 5VSB output shall be present when an AC input greater than the power supply turn on voltage is applied. There should be load sharing in the standby rail.

10.2.3 Voltage Regulation

The power supply output voltages must stay within the following voltage limits when operating at steady state and dynamic loading conditions. These limits include the peak-peak ripple/noise. These shall be measured at the output connectors.

Table 86. Voltage Regulation Limits

Parameter	Tolerance	Min	Nom	Max	Units
+12V	- 5%/+5%	+11.40	+12.00	+12.60	V _{rms}
+5V stby	- 5%/+5%	+4.75	+5.00	+5.25	V _{rms}

10.2.4 Dynamic Loading

The output voltages shall remain within limits specified for the step loading and capacitive loading specified in the table below. The load transient repetition rate shall be tested between 50Hz and 5kHz at duty cycles ranging from 10%-90%. The load transient repetition rate is only a test specification. The Δ step load may occur anywhere within the MIN load to the MAX load conditions.

Table 87. Transient Load Requirements

Output	Δ Step Load Size	Load Slew Rate	Test capacitive Load
+5VSB	1.0A	0.25 A/ μ sec	20 μ F
+12V	60% of max load	0.25 A/ μ sec	2000 μ F

Note: For dynamic condition +12V min loading is 1A.

10.2.5 Capacitive Loading

The power supply shall be stable and meet all requirements with the following capacitive loading ranges.

Table 88. Capacitive Loading Conditions

Output	MIN	MAX	Units
+5VSB	20	3100	μ F
+12V	500	25000	μ F

10.2.6 Grounding

The output ground of the pins of the power supply provides the output power return path. The output connector ground pins shall be connected to the safety ground (power supply enclosure). This grounding should be well designed to ensure passing the max allowed Common Mode Noise levels.

The power supply shall be provided with a reliable protective earth ground. All secondary circuits shall be connected to protective earth ground. Resistance of the ground returns to chassis shall not exceed 1.0 m Ω . This path may be used to carry DC current.

10.2.7 Closed loop stability

The power supply shall be unconditionally stable under all line/load/transient load conditions including specified capacitive load ranges. A minimum of **45 degrees phase margin** and **10dB-gain margin** is required. Closed-loop stability must be ensured at the maximum and minimum loads as applicable.

10.2.8 Residual Voltage Immunity in Standby mode

The power supply should be immune to any residual voltage placed on its outputs (Typically a leakage voltage through the system from standby output) up to 500mV. There shall be no

additional heat generated, nor stressing of any internal components with this voltage applied to any individual or all outputs simultaneously. It also should not trip the protection circuits during turn on.

The residual voltage at the power supply outputs for no load condition shall not exceed 100mV when AC voltage is applied and the PSON# signal is de-asserted.

10.2.9 Common Mode Noise

The Common Mode noise on any output shall not exceed **350mV pk-pk** over the frequency band of 10Hz to 20MHz.

10.2.10 Soft Starting

The Power Supply shall contain control circuit which provides monotonic soft start for its outputs without overstress of the AC line or any power supply components at any specified AC line or load conditions.

10.2.11 Zero Load Stability Requirements

When the power subsystem operates in a no load condition, it does not need to meet the output regulation specification, but it must operate without any tripping of over-voltage or other fault circuitry. When the power subsystem is subsequently loaded, it must begin to regulate and source current without fault.

10.2.12 Hot Swap Requirements

Hot swapping a power supply is the process of inserting and extracting a power supply from an operating power system. During this process the output voltages shall remain within the limits with the capacitive load specified. The hot swap test must be conducted when the system is operating under static, dynamic, and zero loading conditions.

10.2.13 Forced Load Sharing

The +12V output will have active load sharing. The output will share within 10% at full load. The failure of a power supply should not affect the load sharing or output voltages of the other supplies still operating. The supplies must be able to load share in parallel and operate in a hot-swap/redundant **1+1** configurations. The 12VSB output is not required to actively share current between power supplies (passive sharing). The 12VSB output of the power supplies are connected together in the system so that a failure or hot swap of a redundant power supply does not cause these outputs to go out of regulation in the system.

10.2.14 Ripple/Noise

The maximum allowed ripple/noise output of the power supply is defined in the following table. This is measured over a bandwidth of 10Hz to 20MHz at the power supply output connectors. A 10 μ F tantalum capacitor in parallel with a 0.1 μ F ceramic capacitor is placed at the point of measurement.

Table 89. Ripples and Noise

+12V main	+5VSB
120mVp-p	50mVp-p

10.2.15 Timing Requirement

These are the timing requirements for the power supply operation. The output voltages must rise from 10% to within regulation limits ($T_{\text{vout_rise}}$) within 5 to 70ms. For 5VSB, it is allowed to rise

from 1.0 to 25ms. **All outputs must rise monotonically.** The following table shows the timing requirements for the power supply being turned on and off through the AC input, with PSON held low and the PSON signal, with the AC input applied.

Table 90. Timing Requirements

Item	Description	Min	Max	Units
T_{vout_rise}	Output voltage rise time	5.0 *	70 *	ms
$T_{sb_on_delay}$	Delay from AC being applied to 5VSB being within regulation.		1500	ms
$T_{ac_on_delay}$	Delay from AC being applied to all output voltages being within regulation.		3000	ms
T_{vout_holdup}	Time 12VI output voltage stay within regulation after loss of AC.	13		ms
T_{pwok_holdup}	Delay from loss of AC to de-assertion of PWOK	12		ms
$T_{pson_on_delay}$	Delay from PSON# active to output voltages within regulation limits.	5	400	ms
T_{pson_pwok}	Delay from PSON# deactivate to PWOK being de-asserted.		5	ms
T_{pwok_on}	Delay from output voltages within regulation limits to PWOK asserted at turn on.	100	500	ms
T_{pwok_off}	Delay from PWOK de-asserted to output voltages dropping out of regulation limits.	1		ms
T_{pwok_low}	Duration of PWOK being in the de-asserted state during an off/on cycle using AC or the PSON signal.	100		ms
T_{sb_vout}	Delay from 5VSB being in regulation to O/Ps being in regulation at AC turn on.	50	1000	ms
T_{5VSB_holdup}	Time the 5VSB output voltage stays within regulation after loss of AC.	70		ms

* The 5VSB output voltage rise time shall be from 1.0ms to 25ms.

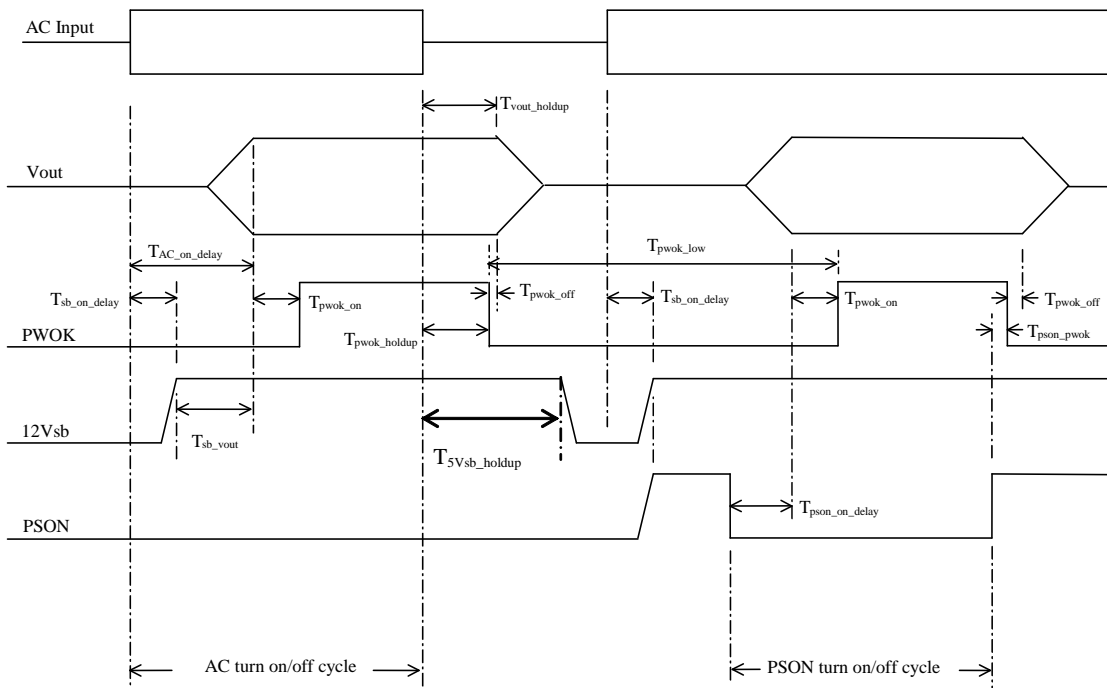

Figure 52. Turn On/Off Timing (Power Supply Signals)

Appendix A: Integration and Usage Tips

- When adding or removing components or peripherals from the server board, AC power must be removed. With AC power plugged into the server board, 5-V standby is still present even though the server board is powered off.
- This server board supports The Intel® Xeon® Processor E5-2600 product family with a Thermal Design Power (TDP) of up to and including 135 Watts. Previous generations of the Intel® Xeon® processors are not supported.
- Processors must be installed in order. CPU 1 must be populated for the server board to operate.
- The server board includes a pre-installed CPU power cable harness. The cable harness must be installed and fully seated in each connector for the server board to operate.
- On the back edge of the server board are eight diagnostic LEDs that display a sequence of amber POST codes during the boot process. If the server board hangs during POST, the LEDs display the last POST event run before the hang.
- This server board only supports registered DDR3 DIMMs (RDIMMs) and unbuffered DDR3 DIMMs (UDIMMs). Mixing of RDIMMs and UDIMMs is not supported.
- For the best performance, the number of DDR3 DIMMs installed should be balanced across both processor sockets and memory channels. For example, a two-DIMM configuration performs better than a one-DIMM configuration. In a two-DIMM configuration, DIMMs should be installed in DIMM sockets A1 and D1. A six-DIMM configuration (DIMM sockets A1, B1, C1, D1, E1, and F1) performs better than a three-DIMM configuration (DIMM sockets A1, B1, and C1).
- The Intel® Remote Management Module 4 (Intel® RMM4) connector is not compatible with any previous versions of the Intel® Remote Management Module (Product Order Code – AXXRMM, AXXRMM2, AXXRMM3).
- Clear the CMOS with AC power cord plugged. Removing the AC power before performing the CMOS clear operation causes the system to automatically power up and immediately power down after the CMOS clear procedure is followed and AC power is re-applied. If this happens, remove the AC power cord, wait 30 seconds, and then re-connect the AC power cord. Power up the system and proceed to the <F2> BIOS Setup utility to reset the desired settings.
- Normal Integrated BMC functionality is disabled with the BMC Force Update jumper set to the “enabled” position (pins 2-3). The server should never be run with the BMC Force Update jumper set in this position and should only be used when the standard firmware update process fails. This jumper should remain in the default (disabled) position (pins 1-2) when the server is running normally.
- When performing a normal BIOS update procedure, the BIOS recovery jumper must be set to its default position (pins 1-2).

Appendix B: Integrated BMC Sensor Tables

This appendix lists the sensor identification numbers and information about the sensor type, name, supported thresholds, assertion and de-assertion information, and a brief description of the sensor purpose. See the *Intelligent Platform Management Interface Specification, Version 2.0*, for sensor and event/reading-type table information.

- **Sensor Type**

The Sensor Type values are the values enumerated in the *Sensor Type Codes* table in the IPMI specification. The Sensor Type provides the context in which to interpret the sensor, such as the physical entity or characteristic that is represented by this sensor.

- **Event/Reading Type**

The Event/Reading Type values are from the *Event/Reading Type Code Ranges* and *Generic Event/Reading Type Codes* tables in the IPMI specification. Digital sensors are a specific type of discrete sensor, which have only two states.

- **Event Offset/Triggers**

Event Thresholds are event-generating thresholds for threshold types of sensors.

- [u,l][nr,c,nc]: upper non-recoverable, upper critical, upper non-critical, lower non-recoverable, lower critical, lower non-critical
- uc, lc: upper critical, lower critical

Event Triggers are supported event-generating offsets for discrete type sensors. The offsets can be found in the *Generic Event/Reading Type Codes* or *Sensor Type Codes* tables in the IPMI specification, depending on whether the sensor event/reading type is generic or a sensor-specific response.

- **Assertion/De-assertion Enables**

Assertion and de-assertion indicators reveal the type of events the sensor generates:

- As: Assertions
- De: De-assertion

- **Readable Value/Offsets**

- Readable Value indicates the type of value returned for threshold and other non-discrete type sensors.
- Readable Offsets indicate the offsets for discrete sensors that are readable with the *Get Sensor Reading* command. Unless otherwise indicated, all event triggers are readable; Readable Offsets consist of the reading type offsets that do not generate events.

- **Event Data**

Event data is the data that is included in an event message generated by the sensor. For threshold-based sensors, the following abbreviations are used:

- R: Reading value
- T: Threshold value

- **Rearm Sensors**

The rearm is a request for the event status for a sensor to be rechecked and updated upon a transition between good and bad states. Rearming the sensors can be done manually or automatically. This column indicates the type supported by the sensor. The following abbreviations are used to describe a sensor:

- A: Auto-rearm
- M: Manual rearm

- **Default Hysteresis**

The hysteresis setting applies to all thresholds of the sensor. This column provides the count of hysteresis for the sensor, which can be 1 or 2 (positive or negative hysteresis).

- **Criticality**

Criticality is a classification of the severity and nature of the condition. It also controls the behavior of the Control Panel Status LED.

- **Standby**

Some sensors operate on standby power. These sensors may be accessed and/or generate events when the main (system) power is off, but AC power is present.

Table 91. BMC Core Sensors for EPSD Platforms Based on Intel® Xeon® Processor E5 4600/2600/2400/1600 Product Families

Full Sensor Name (Sensor name in SDR)	Sensor #	Platform Applicability	Sensor Type	Event/Reading Type	Event Offset Triggers	Contrib. To System Status	Assert/De-assert	Readable Value/Offsets	Event Data	Rearm	Stand-by
Power Unit Status (<i>Pwr Unit Status</i>)	01h	All	Power Unit 09h	Sensor Specific 6Fh	00 - Power down	OK	As and De	-	Trig Offset	A	X
					02 - 240 VA power down	Fatal					
					04 - A/C lost	OK					
					05 - Soft power control failure	Fatal					
					06 - Power unit failure						
Power Unit Redundancy ¹ (<i>Pwr Unit Redund</i>)	02h	Chassis-specific	Power Unit 09h	Generic 0Bh	00 - Fully Redundant	OK	As and De	-	Trig Offset	M	X
					01 - Redundancy lost	Degraded					
					02 - Redundancy degraded	Degraded					
					03 - Non-redundant: sufficient resources. Transition from full redundant state.	Degraded					
					04 - Non-redundant: sufficient resources. Transition from insufficient state.	Degraded					
					05 - Non-redundant: insufficient resources	Fatal					
					06 - Redundant: degraded from fully redundant state.	Degraded					
					07 - Redundant: Transition from non-redundant state.	Degraded					

Full Sensor Name (Sensor name in SDR)	Sensor #	Platform Applicability	Sensor Type	Event/Reading Type	Event Offset Triggers	Contrib. To System Status	Assert/De-assert	Readable Value/Offsets	Event Data	Rearm	Stand-by
IPMI Watchdog (<i>IPMI Watchdog</i>)	03h	All	Watchdog 2 23h	Sensor Specific 6Fh	00 - Timer expired, status only	OK	As	-	Trig Offset	A	X
					01 - Hard reset						
					02 - Power down						
					03 - Power cycle						
					08 - Timer interrupt						
Physical Security (<i>Physical Scrtcy</i>)	04h	Chassis Intrusion is chassis-specific	Physical Security 05h	Sensor Specific 6Fh	04 - LAN leash lost	Degraded OK	As and De	-	Trig Offset	A	X
FP Interrupt (<i>FP NMI Diag Int</i>)	05h	Chassis - specific	Critical Interrupt 13h	Sensor Specific 6Fh	00 - Front panel NMI/diagnostic interrupt	OK	As	-	Trig Offset	A	-
SMI Timeout (<i>SMI Timeout</i>)	06h	All	SMI Timeout F3h	Digital Discrete 03h	01 - State asserted	Fatal	As and De	-	Trig Offset	A	-
System Event Log (<i>System Event Log</i>)	07h	All	Event Logging Disabled 10h	Sensor Specific 6Fh	02 - Log area reset/cleared	OK	As	-	Trig Offset	A	X
System Event (<i>System Event</i>)	08h	All	System Event 12h	Sensor Specific 6Fh	02 - Undetermined system H/W failure 04 - PEF action	Fatal OK	As and De As	-	Trig Offset	A	X
Button Sensor (<i>Button</i>)	09h	All	Button/Switch 14h	Sensor Specific 6Fh	00 - Power Button 02 - Reset Button	OK	AS	-	Trig Offset	A	X
BMC Watchdog	0Ah	All	Mgmt System Health 28h	Digital Discrete 03h	01 - State Asserted	Degraded	As	-	Trig Offset	A	-

Full Sensor Name (Sensor name in SDR)	Sensor #	Platform Applicability	Sensor Type	Event/Reading Type	Event Offset Triggers	Contrib. To System Status	Assert/De-assert	Readable Value/Offsets	Event Data	Rearm	Stand-by
Voltage Regulator Watchdog (VR Watchdog)	0Bh	All	Voltage 02h	Digital Discrete 03h	01 – State Asserted	Fatal	As and De	–	Trig Offset	M	X
Fan Redundancy ¹ (<i>Fan Redundancy</i>)	0Ch	Chassis-specific	Fan 04h	Generic 0Bh	00 - Fully redundant	OK	As and De	–	Trig Offset	A	–
					01 - Redundancy lost	Degraded					
					02 - Redundancy degraded	Degraded					
					03 - Non-redundant: Sufficient resources. Transition from redundant	Degraded					
					04 - Non-redundant: Sufficient resources. Transition from insufficient.	Degraded					
					05 - Non-redundant: insufficient resources.	Non-Fatal					
					06 – Non-Redundant: degraded from fully redundant.	Degraded					
					07 - Redundant degraded from non-redundant	Degraded					
SSB Thermal Trip (<i>SSB Therm Trip</i>)	0Dh	All	Temperature 01h	Digital Discrete 03h	01 – State Asserted	Fatal	As and De	–	Trig Offset	M	X
IO Module Presence (IO Mod Presence)	0Eh	Platform-specific	Module/Board 15h	Digital Discrete 08h	01 – Inserted/Present	OK	As and De	–	Trig Offset	M	-
SAS Module Presence (SAS Mod Presence)	0Fh	Platform-specific	Module/Board 15h	Digital Discrete 08h	01 – Inserted/Present	OK	As and De	–	Trig Offset	M	X

Full Sensor Name (Sensor name in SDR)	Sensor #	Platform Applicability	Sensor Type	Event/Reading Type	Event Offset Triggers	Contrib. To System Status	Assert/De-assert	Readable Value/Offsets	Event Data	Rearm	Stand-by
BMC Firmware Health (BMC FW Health)	10h	All	Mgmt Health 28h	Sensor Specific 6Fh	04 – Sensor Failure	Degraded	As	-	Trig Offset	A	X
System Airflow (System Airflow)	11h	All	Other Units 0Bh	Threshold 01h	-	-	-	Analog	-	-	-
FW Update Status	12h	All	Version Change 2Bh	OEM defined x70h	00h→Update started 01h→Update completed successfully. 02h→Update failure	OK	As	-	Trig Offset	A	-
IO Module2 Presence (IO Mod2 Presence)	13h	Platform-specific	Module/Board 15h	Digital Discrete 08h	01 – Inserted/Present	OK	As and De	-	Trig Offset	M	-
Baseboard Temperature 5 (Platform Specific)	14h	Platform-specific	Temperature 01h	Threshold 01h	[u,l] [c,nc]	nc = Degraded c = Non-fatal	As and De	Analog	R, T	A	X
Baseboard Temperature 6 (Platform Specific)	15h	Platform-specific	Temperature 01h	Threshold 01h	[u,l] [c,nc]	nc = Degraded c = Non-fatal	As and De	Analog	R, T	A	X
IO Module2 Temperature (I/O Mod2 Temp)	16h	Platform-specific	Temperature 01h	Threshold 01h	[u,l] [c,nc]	nc = Degraded c = Non-fatal	As and De	Analog	R, T	A	X
PCI Riser 3 Temperature (PCI Riser 5 Temp)	17h	Platform-specific	Temperature 01h	Threshold 01h	[u,l] [c,nc]	nc = Degraded c = Non-fatal	As and De	Analog	R, T	A	X
PCI Riser 4 Temperature (PCI Riser 4 Temp)	18h	Platform-specific	Temperature 01h	Threshold 01h	[u,l] [c,nc]	nc = Degraded c = Non-fatal	As and De	Analog	R, T	A	X
Baseboard +1.05V Processor3 Vccp (BB +1.05Vccp P3)	19h	Platform-specific	Voltage 02h	Threshold 01h	[u,l] [c,nc]	nc = Degraded c = Non-fatal	As and De	Analog	R, T	A	-

Full Sensor Name (Sensor name in SDR)	Sensor #	Platform Applicability	Sensor Type	Event/Reading Type	Event Offset Triggers	Contrib. To System Status	Assert/Deassert	Readable Value/Offsets	Event Data	Rearm	Stand-by
Baseboard +1.05V Processor4 Vccp (BB +1.05Vccp P4)	1Ah	Platform-specific	Voltage 02h	Threshold 01h	[u,l] [c,nc]	nc = Degraded c = Non-fatal	As and De	Analog	R, T	A	–
Baseboard Temperature 1 (Platform Specific)	20h	Platform-specific	Temperature 01h	Threshold 01h	[u,l] [c,nc]	nc = Degraded c = Non-fatal	As and De	Analog	R, T	A	X
Front Panel Temperature (Front Panel Temp)	21h	All	Temperature 01h	Threshold 01h	[u,l] [c,nc]	nc = Degraded c = Non-fatal	As and De	Analog	R, T	A	X
SSB Temperature (SSB Temp)	22h	All	Temperature 01h	Threshold 01h	[u,l] [c,nc]	nc = Degraded c = Non-fatal	As and De	Analog	R, T	A	X
Baseboard Temperature 2 (Platform Specific)	23h	Platform-specific	Temperature 01h	Threshold 01h	[u,l] [c,nc]	nc = Degraded c = Non-fatal	As and De	Analog	R, T	A	X
Baseboard Temperature 3 (Platform Specific)	24h	Platform-specific	Temperature 01h	Threshold 01h	[u,l] [c,nc]	nc = Degraded c = Non-fatal	As and De	Analog	R, T	A	X
Baseboard Temperature 4 (Platform Specific)	25h	Platform-specific	Temperature 01h	Threshold 01h	[u,l] [c,nc]	nc = Degraded c = Non-fatal	As and De	Analog	R, T	A	X
IO Module Temperature (I/O Mod Temp)	26h	Platform-specific	Temperature 01h	Threshold 01h	[u,l] [c,nc]	nc = Degraded c = Non-fatal	As and De	Analog	R, T	A	X
PCI Riser 1 Temperature (PCI Riser 1 Temp)	27h	Platform-specific	Temperature 01h	Threshold 01h	[u,l] [c,nc]	nc = Degraded c = Non-fatal	As and De	Analog	R, T	A	X
IO Riser Temperature (IO Riser Temp)	28h	Platform-specific	Temperature 01h	Threshold 01h	[u,l] [c,nc]	nc = Degraded c = Non-fatal	As and De	Analog	R, T	A	X
Hot-swap Backplane 1 Temperature (HSBP 1 Temp)	29h	Chassis-specific	Temperature 01h	Threshold 01h	[u,l] [c,nc]	nc = Degraded c = Non-fatal	As and De	Analog	R, T	A	X

Full Sensor Name (Sensor name in SDR)	Sensor #	Platform Applicability	Sensor Type	Event/Reading Type	Event Offset Triggers	Contrib. To System Status	Assert/De-assert	Readable Value/Offsets	Event Data	Rearm	Stand-by
Hot-swap Backplane 2 Temperature (HSBP 2 Temp)	2Ah	Chassis-specific	Temperature 01h	Threshold 01h	[u,l] [c,nc]	nc = Degraded c = Non-fatal	As and De	Analog	R, T	A	X
Hot-swap Backplane 3 Temperature (HSBP 3 Temp)	2Bh	Chassis-specific	Temperature 01h	Threshold 01h	[u,l] [c,nc]	nc = Degraded c = Non-fatal	As and De	Analog	R, T	A	X
PCI Riser 2 Temperature (PCI Riser 2 Temp)	2Ch	Platform-specific	Temperature 01h	Threshold 01h	[u,l] [c,nc]	nc = Degraded c = Non-fatal	As and De	Analog	R, T	A	X
SAS Module Temperature (SAS Mod Temp)	2Dh	Platform-specific	Temperature 01h	Threshold 01h	[u,l] [c,nc]	nc = Degraded c = Non-fatal	As and De	Analog	R, T	A	X
Exit Air Temperature (Exit Air Temp)	2Eh	Chassis & Platform Specific	Temperature 01h	Threshold 01h	[u,l] [c,nc]	nc = Degraded c = Non-fatal	As and De	Analog	R, T	A	X
Network Interface Controller Temperature (LAN NIC Temp)	2Fh	All	Temperature 01h	Threshold 01h	[u,l] [c,nc]	nc = Degraded c = Non-fatal	As and De	Analog	R, T	A	X
Fan Tachometer Sensors (Chassis specific sensor names)	30h–3Fh	Chassis & Platform Specific	Fan 04h	Threshold 01h	[l] [c,nc]	nc = Degraded c = Non-fatal ²	As and De	Analog	R, T	M	-
Fan Present Sensors (Fan x Present)	40h–4Fh	Chassis & Platform Specific	Fan 04h	Generic 08h	01 - Device inserted	OK	As and De	-	Triggered Offset	Auto	-
Power Supply 1 Status (PS1 Status)	50h	Chassis-specific	Power Supply 08h	Sensor Specific 6Fh	00 - Presence	OK	As and De	-	Trig Offset	A	X
					01 - Failure	Degraded					
					02 – Predictive Failure	Degraded					
					03 - A/C lost	Degraded					
					06 – Configuration error	OK					
Power Supply 2 Status (PS2 Status)	51h	Chassis-specific	Power Supply 08h	Sensor Specific	00 - Presence	OK	As and	-	Trig Offset	A	X
					01 - Failure	Degraded					

Full Sensor Name (Sensor name in SDR)	Sensor #	Platform Applicability	Sensor Type	Event/Reading Type	Event Offset Triggers	Contrib. To System Status	Assert/De-assert	Readable Value/Offsets	Event Data	Rearm	Stand-by
				6Fh	02 – Predictive Failure	Degraded	De				
					03 - A/C lost	Degraded					
					06 – Configuration error	OK					
Power Supply 1 AC Power Input (PS1 Power In)	54h	Chassis-specific	Other Units 0Bh	Threshold 01h	[u] [c,nc]	nc = Degraded c = Non-fatal	As and De	Analog	R, T	A	X
Power Supply 2 AC Power Input (PS2 Power In)	55h	Chassis-specific	Other Units 0Bh	Threshold 01h	[u] [c,nc]	nc = Degraded c = Non-fatal	As and De	Analog	R, T	A	X
Power Supply 1 +12V % of Maximum Current Output (PS1 Curr Out %)	58h	Chassis-specific	Current 03h	Threshold 01h	[u] [c,nc]	nc = Degraded c = Non-fatal	As and De	Analog	R, T	A	X
Power Supply 2 +12V % of Maximum Current Output (PS2 Curr Out %)	59h	Chassis-specific	Current 03h	Threshold 01h	[u] [c,nc]	nc = Degraded c = Non-fatal	As and De	Analog	R, T	A	X
Power Supply 1 Temperature (PS1 Temperature)	5Ch	Chassis-specific	Temperature 01h	Threshold 01h	[u] [c,nc]	nc = Degraded c = Non-fatal	As and De	Analog	R, T	A	X
Power Supply 2 Temperature (PS2 Temperature)	5Dh	Chassis-specific	Temperature	Threshold 01h	[u] [c,nc]	nc = Degraded c = Non-fatal	As and De	Analog	R, T	A	X
Hard Disk Drive 16 - 24 Status (HDD 16 - 24 Status)	60h - 68h	Chassis-specific	Drive Slot 0Dh	Sensor Specific 6Fh	00 - Drive Presence	OK	As and De	-	Trig Offset	A	X
					01- Drive Fault	Degraded					
07 - Rebuild/Remap in progress	Degraded										
	69h - 6Bh	Chassis-specific	Microcontroller 16h	Discrete 0Ah	04- transition to Off Line	Degraded		-	Trig Offset		X

Full Sensor Name (Sensor name in SDR)	Sensor #	Platform Applicability	Sensor Type	Event/Reading Type	Event Offset Triggers	Contrib. To System Status	Assert/Deassert	Readable Value/Offsets	Event Data	Rearm	Stand-by
Processor 1 Status (P1 Status)	70h	All	Processor 07h	Sensor Specific 6Fh	01 - Thermal trip	Fatal	As and De	-	Trig Offset	M	X
					07 - Presence	OK					
Processor 2 Status (P2 Status)	71h	All	Processor 07h	Sensor Specific 6Fh	01 - Thermal trip	Fatal	As and De	-	Trig Offset	M	X
					07 - Presence	OK					
Processor 3 Status (P3 Status)	72h	Platform-specific	Processor 07h	Sensor Specific 6Fh	01 - Thermal trip	Fatal	As and De	-	Trig Offset	M	X
					07 - Presence	OK					
Processor 4 Status (P4 Status)	73h	Platform-specific	Processor 07h	Sensor Specific 6Fh	01 - Thermal trip	Fatal	As and De	-	Trig Offset	M	X
					07 - Presence	OK					
Processor 1 Thermal Margin (P1 Therm Margin)	74h	All	Temperature 01h	Threshold 01h	-	-	-	Analog	R, T	A	-
Processor 2 Thermal Margin (P2 Therm Margin)	75h	All	Temperature 01h	Threshold 01h	-	-	-	Analog	R, T	A	-
Processor 3 Thermal Margin (P3 Therm Margin)	76h	Platform-specific	Temperature 01h	Threshold 01h	-	-	-	Analog	R, T	A	-
Processor 4 Thermal Margin (P4 Therm Margin)	77h	Platform-specific	Temperature 01h	Threshold 01h	-	-	-	Analog	R, T	A	-
Processor 1 Thermal Control % (P1 Therm Ctrl %)	78h	All	Temperature 01h	Threshold 01h	[u] [c,nc]	nc = Degraded c = Non-fatal	As and De	Analog	Trig Offset	A	-
Processor 2 Thermal Control % (P2 Therm Ctrl %)	79h	All	Temperature 01h	Threshold 01h	[u] [c,nc]	nc = Degraded c = Non-fatal	As and De	Analog	Trig Offset	A	-
Processor 3 Thermal Control % (P3 Therm Ctrl %)	7Ah	Platform-specific	Temperature 01h	Threshold 01h	[u] [c,nc]	nc = Degraded c = Non-fatal	As and De	Analog	Trig Offset	A	-
Processor 4 Thermal Control % (P4 Therm Ctrl %)	7Bh	Platform-specific	Temperature 01h	Threshold 01h	[u] [c,nc]	nc = Degraded c = Non-fatal	As and De	Analog	Trig Offset	A	-

Full Sensor Name (Sensor name in SDR)	Sensor #	Platform Applicability	Sensor Type	Event/Reading Type	Event Offset Triggers	Contrib. To System Status	Assert/De-assert	Readable Value/Offsets	Event Data	Rearm	Stand-by
Processor 1 ERR2 Timeout (P1 ERR2)	7Ch	All	Processor 07h	Digital Discrete 03h	01 – State Asserted	fatal	As and De	–	Trig Offset	A	–
Processor 2 ERR2 Timeout (P2 ERR2)	7Dh	All	Processor 07h	Digital Discrete 03h	01 – State Asserted	fatal	As and De	–	Trig Offset	A	–
Processor 3 ERR2 Timeout (P3 ERR2)	7Eh	Platform-specific	Processor 07h	Digital Discrete 03h	01 – State Asserted	fatal	As and De	–	Trig Offset	A	–
Processor 4 ERR2 Timeout (P4 ERR2)	7Fh	Platform-specific	Processor 07h	Digital Discrete 03h	01 – State Asserted	fatal	As and De	–	Trig Offset	A	–
Catastrophic Error (CATERR)	80h	All	Processor 07h	Digital Discrete 03h	01 – State Asserted	fatal	As and De	–	Trig Offset	M	–
Processor1 MSID Mismatch (P1 MSID Mismatch)	81h	All	Processor 07h	Digital Discrete 03h	01 – State Asserted	fatal	As and De	–	Trig Offset	M	–
Processor Population Fault (CPU Missing)	82h	All	Processor 07h	Digital Discrete 03h	01 – State Asserted	Fatal	As and De	–	Trig Offset	M	–
Processor 1 DTS Thermal Margin (P1 DTS Therm Mgn)	83h	All	Temperature 01h	Threshold 01h	–	–	–	Analog	R, T	A	–
Processor 2 DTS Thermal Margin (P2 DTS Therm Mgn)	84h	All	Temperature 01h	Threshold 01h	–	–	–	Analog	R, T	A	–
Processor 3 DTS Thermal Margin (P3 DTS Therm Mgn)	85h	All	Temperature 01h	Threshold 01h	–	–	–	Analog	R, T	A	–
Processor 4 DTS Thermal Margin (P4 DTS Therm Mgn)	86h	All	Temperature 01h	Threshold 01h	–	–	–	Analog	R, T	A	–

Full Sensor Name (Sensor name in SDR)	Sensor #	Platform Applicability	Sensor Type	Event/Reading Type	Event Offset Triggers	Contrib. To System Status	Assert/De-assert	Readable Value/Offsets	Event Data	Rearm	Stand-by
Processor2 MSID Mismatch (P2 MSID Mismatch)	87h	All	Processor 07h	Digital Discrete 03h	01 – State Asserted	fatal	As and De	–	Trig Offset	M	–
Processor 1 VRD Temperature (P1 VRD Hot)	90h	All	Temperature 01h	Digital Discrete 05h	01 - Limit exceeded	Non-fatal	As and De	–	Trig Offset	M	–
Processor 2 VRD Temperature (P2 VRD Hot)	91h	All	Temperature 01h	Digital Discrete 05h	01 - Limit exceeded	Non-fatal	As and De	–	Trig Offset	M	–
Processor 3 VRD Temperature (P3 VRD Hot)	92h	All	Temperature 01h	Digital Discrete 05h	01 - Limit exceeded	Fatal	As and De	–	Trig Offset	M	–
Processor 4 VRD Temperature (P4 VRD Hot)	93h	All	Temperature 01h	Digital Discrete 05h	01 - Limit exceeded	Fatal	As and De	–	Trig Offset	M	–
Processor 1 Memory VRD Hot 0-1 (P1 Mem01 VRD Hot)	94h	All	Temperature 01h	Digital Discrete 05h	01 - Limit exceeded	Non-fatal	As and De	–	Trig Offset	A	–
Processor 1 Memory VRD Hot 2-3 (P1 Mem23 VRD Hot)	95h	All	Temperature 01h	Digital Discrete 05h	01 - Limit exceeded	Non-fatal	As and De	–	Trig Offset	A	–
Processor 2 Memory VRD Hot 0-1 (P2 Mem01 VRD Hot)	96h	All	Temperature 01h	Digital Discrete 05h	01 - Limit exceeded	Non-fatal	As and De	–	Trig Offset	A	–
Processor 2 Memory VRD Hot 2-3 (P2 Mem23 VRD Hot)	97h	All	Temperature 01h	Digital Discrete 05h	01 - Limit exceeded	Non-fatal	As and De	–	Trig Offset	A	–
Processor 3 Memory VRD Hot 0-1 (P3 Mem01 VRD Hot)	98h	All	Temperature 01h	Digital Discrete 05h	01 - Limit exceeded	Non-fatal	As and De	–	Trig Offset	A	–

Full Sensor Name (Sensor name in SDR)	Sensor #	Platform Applicability	Sensor Type	Event/Reading Type	Event Offset Triggers	Contrib. To System Status	Assert/De-assert	Readable Value/Offsets	Event Data	Rearm	Stand-by
Processor 3 Memory VRD Hot 2-3 (P4 Mem23 VRD Hot)	99h	All	Temperature 01h	Digital Discrete 05h	01 - Limit exceeded	Non-fatal	As and De	-	Trig Offset	A	-
Processor 4 Memory VRD Hot 0-1 (P4 Mem01 VRD Hot)	9Ah	All	Temperature 01h	Digital Discrete 05h	01 - Limit exceeded	Non-fatal	As and De	-	Trig Offset	A	-
Processor 4 Memory VRD Hot 2-3 (P4 Mem23 VRD Hot)	9Bh	All	Temperature 01h	Digital Discrete 05h	01 - Limit exceeded	Non-fatal	As and De	-	Trig Offset	A	-
Power Supply 1 Fan Tachometer 1 (PS1 Fan Tach 1)	A0h	Chassis-specific	Fan 04h	Generic – digital discrete	01 – State Asserted	Non-fatal	As and De	-	Trig Offset	M	-
Power Supply 1 Fan Tachometer 2 (PS1 Fan Tach 2)	A1h	Chassis-specific	Fan 04h	Generic – digital discrete	01 – State Asserted	Non-fatal	As and De	-	Trig Offset	M	-
Power Supply 2 Fan Tachometer 1 (PS2 Fan Tach 1)	A4h	Chassis-specific	Fan 04h	Generic – digital discrete	01 – State Asserted	Non-fatal	As and De	-	Trig Offset	M	-
Power Supply 2 Fan Tachometer 2 (PS2 Fan Tach 2)	A5h	Chassis-specific	Fan 04h	Generic – digital discrete	01 – State Asserted	Non-fatal	As and De	-	Trig Offset	M	-
Processor 1 DIMM Aggregate Thermal Margin 1 (P1 DIMM Thrm Mrgn1)	B0h	All	Temperature 01h	Threshold 01h	[u,l] [c,nc]	nc = Degraded c = Non-fatal	As and De	Analog	R, T	A	-
Processor 1 DIMM Aggregate Thermal Margin 2 (P1 DIMM Thrm Mrgn2)	B1h	All	Temperature 01h	Threshold 01h	[u,l] [c,nc]	nc = Degraded c = Non-fatal	As and De	Analog	R, T	A	-
Processor 2 DIMM Aggregate Thermal Margin 1 (P2 DIMM Thrm Mrgn1)	B2h	All	Temperature 01h	Threshold 01h	[u,l] [c,nc]	nc = Degraded c = Non-fatal	As and De	Analog	R, T	A	-
Processor 2 DIMM Aggregate Thermal Margin 2 (P2 DIMM Thrm Mrgn2)	B3h	All	Temperature 01h	Threshold 01h	[u,l] [c,nc]	nc = Degraded c = Non-fatal	As and De	Analog	R, T	A	-

Full Sensor Name (Sensor name in SDR)	Sensor #	Platform Applicability	Sensor Type	Event/Reading Type	Event Offset Triggers	Contrib. To System Status	Assert/De-assert	Readable Value/Offsets	Event Data	Rearm	Stand-by
Processor 3 DIMM Aggregate Thermal Margin 1 (P3 DIMM Thrm Mrgn1)	B4h	Platform Specific	Temperature 01h	Threshold 01h	[u,l] [c,nc]	nc = Degraded c = Non-fatal	As and De	Analog	R, T	A	-
Processor 3 DIMM Aggregate Thermal Margin 2 (P3 DIMM Thrm Mrgn2)	B5h	Platform Specific	Temperature 01h	Threshold 01h	[u,l] [c,nc]	nc = Degraded c = Non-fatal	As and De	Analog	R, T	A	-
Processor 4 DIMM Aggregate Thermal Margin 1 (P4 DIMM Thrm Mrgn1)	B6h	Platform Specific	Temperature 01h	Threshold 01h	[u,l] [c,nc]	nc = Degraded c = Non-fatal	As and De	Analog	R, T	A	-
Processor 4 DIMM Aggregate Thermal Margin 2 (P4 DIMM Thrm Mrgn2)	B7h	Platform Specific	Temperature 01h	Threshold 01h	[u,l] [c,nc]	nc = Degraded c = Non-fatal	As and De	Analog	R, T	A	-
Fan Tachometer Sensors (Chassis specific sensor names)	BAh-BFh	Chassis & Platform Specific	Fan 04h	Threshold 01h	[l] [c,nc]	nc = Degraded c = Non-fatal ²	As and De	Analog	R, T	M	-
Processor 1 DIMM Thermal Trip (P1 Mem Thrm Trip)	C0h	All	Memory 0Ch	Digital Discrete 03h	0A- Critical overtemperature	Fatal	As and De	-	Trig Offset	M	-
Processor 2 DIMM Thermal Trip (P2 Mem Thrm Trip)	C1h	All	Memory 0Ch	Digital Discrete 03h	0A- Critical overtemperature	Fatal	As and De	-	Trig Offset	M	-
Processor 3 DIMM Thermal Trip (P3 Mem Thrm Trip)	C2h	All	Memory 0Ch	Digital Discrete 03h	0A- Critical overtemperature	Fatal	As and De	-	Trig Offset	M	X
Processor 4 DIMM Thermal Trip (P4 Mem Thrm Trip)	C3h	All	Memory 0Ch	Digital Discrete 03h	0A- Critical overtemperature	Fatal	As and De	-	Trig Offset	M	X
Global Aggregate Temperature Margin 1 (Agg Therm Mrgn 1)	C8h	Platform Specific	Temperature 01h	Threshold 01h	-	-	-	Analog	R, T	A	-
Global Aggregate Temperature Margin 2 (Agg Therm Mrgn 2)	C9h	Platform Specific	Temperature 01h	Threshold 01h	-	-	-	Analog	R, T	A	-

Full Sensor Name (Sensor name in SDR)	Sensor #	Platform Applicability	Sensor Type	Event/Reading Type	Event Offset Triggers	Contrib. To System Status	Assert/De-assert	Readable Value/Offsets	Event Data	Rearm	Stand-by
Global Aggregate Temperature Margin 3 (Agg Therm Mrgn 3)	CAh	Platform Specific	Temperature 01h	Threshold 01h	–	–	–	Analog	R, T	A	–
Global Aggregate Temperature Margin 4 (Agg Therm Mrgn 4)	CBh	Platform Specific	Temperature 01h	Threshold 01h	–	–	–	Analog	R, T	A	–
Global Aggregate Temperature Margin 5 (Agg Therm Mrgn 5)	CCh	Platform Specific	Temperature 01h	Threshold 01h	–	–	–	Analog	R, T	A	–
Global Aggregate Temperature Margin 6 (Agg Therm Mrgn 6)	CDh	Platform Specific	Temperature 01h	Threshold 01h	–	–	–	Analog	R, T	A	–
Global Aggregate Temperature Margin 7 (Agg Therm Mrgn 7)	CEh	Platform Specific	Temperature 01h	Threshold 01h	–	–	–	Analog	R, T	A	–
Global Aggregate Temperature Margin 8 (Agg Therm Mrgn 8)	CFh	Platform Specific	Temperature 01h	Threshold 01h	–	–	–	Analog	R, T	A	–
Baseboard +12V (BB +12.0V)	D0h	All	Voltage 02h	Threshold 01h	[u,l] [c,nc]	nc = Degraded c = Non-fatal	As and De	Analog	R, T	A	–
Baseboard +5V (BB +5.0V)	D1h	All	Voltage 02h	Threshold 01h	[u,l] [c,nc]	nc = Degraded c = Non-fatal	As and De	Analog	R, T	A	–
Baseboard +3.3V (BB +3.3V)	D2h	All	Voltage 02h	Threshold 01h	[u,l] [c,nc]	nc = Degraded c = Non-fatal	As and De	Analog	R, T	A	–
Baseboard +5V Stand-by (BB +5.0V STBY)	D3h	All	Voltage 02h	Threshold 01h	[u,l] [c,nc]	nc = Degraded c = Non-fatal	As and De	Analog	R, T	A	X
Baseboard +3.3V Auxiliary (BB +3.3V AUX)	D4h	All	Voltage 02h	Threshold 01h	[u,l] [c,nc]	nc = Degraded c = Non-fatal	As and De	Analog	R, T	A	X
Baseboard +1.05V Processor1 Vccp (BB +1.05Vccp P1)	D6h	All	Voltage 02h	Threshold 01h	[u,l] [c,nc]	nc = Degraded c = Non-fatal	As and De	Analog	R, T	A	–

Full Sensor Name (Sensor name in SDR)	Sensor #	Platform Applicability	Sensor Type	Event/Reading Type	Event Offset Triggers	Contrib. To System Status	Assert/De-assert	Readable Value/Offsets	Event Data	Rearm	Stand-by
Baseboard +1.05V Processor2 Vccp (BB +1.05Vccp P2)	D7h	All	Voltage 02h	Threshold 01h	[u,l] [c,nc]	nc = Degraded c = Non-fatal	As and De	Analog	R, T	A	–
Baseboard +1.5V P1 Memory AB VDDQ (BB +1.5 P1MEM AB)	D8h	All	Voltage 02h	Threshold 01h	[u,l] [c,nc]	nc = Degraded c = Non-fatal	As and De	Analog	R, T	A	–
Baseboard +1.5V P1 Memory CD VDDQ (BB +1.5 P1MEM CD)	D9h	All	Voltage 02h	Threshold 01h	[u,l] [c,nc]	nc = Degraded c = Non-fatal	As and De	Analog	R, T	A	–
Baseboard +1.5V P2 Memory AB VDDQ (BB +1.5 P2MEM AB)	DAh	All	Voltage 02h	Threshold 01h	[u,l] [c,nc]	nc = Degraded c = Non-fatal	As and De	Analog	R, T	A	–
Baseboard +1.5V P2 Memory CD VDDQ (BB +1.5 P2MEM CD)	DBh	All	Voltage 02h	Threshold 01h	[u,l] [c,nc]	nc = Degraded c = Non-fatal	As and De	Analog	R, T	A	–
Baseboard +1.8V Aux (BB +1.8V AUX)	DCh	All	Voltage 02h	Threshold 01h	[u,l] [c,nc]	nc = Degraded c = Non-fatal	As and De	Analog	R, T	A	–
Baseboard +1.1V Stand-by (BB +1.1V STBY)	DDh	All	Voltage 02h	Threshold 01h	[u,l] [c,nc]	nc = Degraded c = Non-fatal	As and De	Analog	R, T	A	–
Baseboard CMOS Battery (BB +3.3V Vbat)	DEh	All	Voltage 02h	Threshold 01h	[u,l] [c,nc]	nc = Degraded c = Non-fatal	As and De	Analog	R, T	A	–
Baseboard +1.35V P1 Low Voltage Memory AB VDDQ (BB +1.35 P1LV AB)	E4h	All	Voltage 02h	Threshold 01h	[u,l] [c,nc]	nc = Degraded c = Non-fatal	As and De	Analog	R, T	A	–
Baseboard +1.35V P1 Low Voltage Memory CD VDDQ (BB +1.35 P1LV CD)	E5h	All	Voltage 02h	Threshold 01h	[u,l] [c,nc]	nc = Degraded c = Non-fatal	As and De	Analog	R, T	A	–
Baseboard +1.35V P2 Low Voltage Memory AB VDDQ (BB +1.35 P2LV AB)	E6h	All	Voltage 02h	Threshold 01h	[u,l] [c,nc]	nc = Degraded c = Non-fatal	As and De	Analog	R, T	A	–

Full Sensor Name (Sensor name in SDR)	Sensor #	Platform Applicability	Sensor Type	Event/Reading Type	Event Offset Triggers	Contrib. To System Status	Assert/Deassert	Readable Value/Offsets	Event Data	Rearm	Stand-by
Baseboard +1.35V P2 Low Voltage Memory CD VDDQ (BB +1.35 P2LV CD)	E7h	All	Voltage 02h	Threshold 01h	[u,l] [c,nc]	nc = Degraded c = Non-fatal	As and De	Analog	R, T	A	-
Baseboard +3.3V Riser 1 Power Good (BB +3.3 RSR1 PGD)	EAh	Platform Specific	Voltage 02h	Threshold 01h	[u,l] [c,nc]	nc = Degraded c = Non-fatal	As and De	Analog	R, T	A	-
Baseboard +3.3V Riser 2 Power Good (BB +3.3 RSR2 PGD)	EBh	Platform Specific	Voltage 02h	Threshold 01h	[u,l] [c,nc]	nc = Degraded c = Non-fatal	As and De	Analog	R, T	A	-
Hard Disk Drive 1 -15 Status (HDD 1 - 15 Status)	F0h - FEh	Chassis-specific	Drive Slot 0Dh	Sensor Specific 6Fh	00 - Drive Presence	OK	As and De	-	Trig Offset	A	X
					01- Drive Fault	Degraded					
					07 - Rebuild/Remap in progress	Degraded					

Below content describes Intel® Server Board S2600WP and Server System H2600WP specific information.

Product ID

Bytes 11:12 (product ID) of Get Device ID command response: 4Eh 00h

IPMI Channel ID Assignments

Below table provides the information of BMC channels' assignments:

Table 92. BMC Channels' Assignments

Channel ID	Interface	Supports Sessions
0	Primary IPMB	Yes
1	LAN 1	Yes
2	LAN 2	Yes
3	LAN 3 ¹ (Provided by the Intel® Remote Management Module 4)	Yes
4	Reserved	–
5	USB	No
6	Secondary IPMB	No
7	SMM	No
8 – 0Dh	Reserved	–
0Eh	Self ²	–
0Fh	SMS/Receive Message Queue	No

Notes:

1. Optional HW supported by the server system.
2. Refers to the actual channel used to send the request.

Baseboard Specific Sensors

Voltage:

Table 93. Intel® Server Board S2600WP Voltage Sensors

Intel® Board SKU	Sensor Name	Sensor #	Support Sesnors
S2600WPQ(IB QDR for BIK) SKU (PBA# G17128-XXX) S2600WPQ(IB QDR for Board only) SKU (PBA# G48583-XXX) S2600WPF(IB FDR for BIK) SKU (PBA# G38673-XXX S2600WPF(IB FDR for Board only) SKU (PBA# G48605-XXX)	P0_9V IB CORE	ECh	Yes
	P1_8V IB I/O	EDh	Yes
	P1_2V IB OTHER	EFh	Yes
	Baseboard CMOS Battery	DEh	No
S2600WP(base) SKU (PBA# G38670-XXX)	P0_9V IB CORE	ECh	No
	P1_8V IB I/O	EDh	No
	P1_2V IB OTHER	EFh	No
	Baseboard CMOS Battery	DEh	No

Temperature:

Table 94. Intel® Server Board S2600WP Temperature Sensors

Intel® Board SKU	Sensor Name	Sensor Number #	Supports Sensors
All SKU	BB Inlet Temp	20h	Yes
	HSBP Temp	21h	Yes
	SSB Temp	22h	Yes
	BB BMC Temp	23h	Yes
	CPU1 VR Temp	24h	Yes
	IB QDR Temp	25h	Yes
	IOM Temp	26h	Yes
	PCI Riser 1 Temp	27h	No
	IO Riser Temp	28h	No
	HSBP PSOC	29h	Yes
	HSBP 2 Temp	2Ah	No
	HSBP 3 Temp	2Bh	No
	PCI Riser 2 Temp	2Ch	No
	SAS Mod Temp	2Dh	No
	Exit Air Temp	2Eh	Yes
	Powerville Temp	2Fh	Yes
	DIMM Thrm Mrgn 1	B0h	Yes
	DIMM Thrm Mrgn 2	B1h	Yes
DIMM Thrm Mrgn 3	B2h	Yes	
DIMM Thrm Mrgn 4	B3h	Yes	

ACPI S3 Sleep State Support

Not supported.

Processor Support for Intel® Server Boards S2600WP

- Intel® Xeon processor E5-2600 family, with TDP below 135W.

Supported Chassis

- Intel® Server Chassis – H2312WPJR for 12x3.5" HDD with 1200W PSU
- Intel® Server Chassis – H2312WPKR for 12x3.5" HDD with 1600W PSU
- Intel® Server Chassis – H2216WPJR for 16x2.5" HDD with 1200W PSU
- Intel® Server Chassis – H2216WPKR for 16x2.5" HDD with 1600W PSU

Chassis-specific sensors

Table 95. Intel® Server Chassis H23XXWP and H22XXWP Specific Sensors

Intel® Server Chassis	Sensors	Supports Sensors
H2312WPJR H2312WPKR H2216WPJR H2216WPKR	System Fan 1a #30	Yes
	System Fan 1b #31	Yes
	System Fan 2a #32	Yes
	System Fan 2b #33	Yes
	System Fan 3a #34	Yes
	System Fan 3b #35	Yes
	FAN 1a Present #40	No
	FAN 1b Present #41	No
	FAN 2a Present #42	No
	FAN 2b Present #43	No
	FAN 3a Present #44	No
	FAN 3b Present #45	No
	Physical security (Chassis intrusion) Sensor #04 bit 0	No
	FP interrupt (FP NMI Diag Int) Sensor #05	No

Hot-plug fan support

Not Support

Fan redundancy support

Not Support

Fan domain definition

Table 96. Intel® Server Chassis H23XXWP and H22XXWP Fan Domain Definition

Intel® Server Chassis	Fan Domain	Major Components Cooled (Temperature sensor number)	Fans (Sensor number)
H2312WPJR H2312WPKR H2216WPJR H2216WPKR	0	SSB Temp (22h) BB BMC Temp(23h) P1 VR Temp (24h) IB QDR Temp (25h) IOM Temp (26h) Exit Air Temp (2Eh) Powerville Temp (2Fh) DIMM Thrm Mrgn 1 (B0h) DIMM Thrm Mrgn 2 (B1h) DIMM Thrm Mrgn 3 (B2h) DIMM Thrm Mrgn 4 (B3h) P1 Therm Margin (74h) P2 Therm Margin (75h)	System Fan 1a (30h) System Fan 1b (31h) System Fan 2a (32h) System Fan 2b (33h) System Fan 3a (34h) System Fan 3b (35h)
	2	HSBP 1 Temp (29h)	PS1 1a Fan Fail (A0h)

Intel® Server Chassis	Fan Domain	Major Components Cooled (Temperature sensor number)	Fans (Sensor number)
		PS1 Temperature (5C) PS2 Temperature (5D)	PS1 1b Fan Fail (A1h) PS2 1a Fan Fail (A4h) PS2 1b Fan Fail (A5h)

HSC Availability

- FH2K16X25HSBP(PBA# G16566-XXX) for 16x2.5" HDD used in H2216WPJR/KR
- FH2K12X35HSBP(PBA# G16567-XXX) for 12x3.5" HDD used in H2312WPJR/KR

Power unit and Power Supply support

Table 97. Intel® Server Chassis H23XXWP and H22XXWP Power Supply Support

Power Supply Type	Power Unit Redundancy Support	Power Supply FAN Sensors	
1200W PSU	Yes	Power Supply 1 Fan Tachometer 1	#A0
		Power Supply 1 Fan Tachometer 2	#A1
		Power Supply 2 Fan Tachometer 1	#A4
		Power Supply 2 Fan Tachometer 2	#A5
1600W PSU	Yes	Power Supply 1 Fan Tachometer 1	#A0
		Power Supply 1 Fan Tachometer 2	#A1
		Power Supply 2 Fan Tachometer 1	#A4
		Power Supply 2 Fan Tachometer 2	#A5

Redundant Fans only for Intel® Server Chassis

None

Fan Fault LED support

Not Support

Memory Throttling support

Yes

Power Control Sources

When there is a fan failure and temperature critical event at the same time on Intel® Server System H23XXWP or H22XXWP BMC will turn system power off.

Appendix C: BIOS Sensors and SEL Data

BIOS owns a set of IPMI-compliant Sensors. These are actually divided in ownership between BIOS POST (GID = 01) and BIOS SMI Handler (GID = 33). The SMI Handler Sensors are typically for logging runtime error events, but they are active during POST and may log errors such as Correctable Memory ECC Errors if they occur.

It is important to remember that a Sensor is uniquely identified by the combination of Sensor Owner plus Sensor Number. There are cases where the same Sensor Number is used with different Sensor Owners – this is not a conflict. For example, in the BIOS Sensors list there is a Sensor Number 83h for Sensor Owner 01h (BIOS POST) as well as for Sensor Owner 33h (SMI Handler), but these are two distinct sensors reporting the same type of event from different sources (Generator IDs 01h and 33h).

On the other hand, each distinct Sensor (GID + Sensor Number) is defined by one specific Sensor Type describing the kind of data being reported, and one specific Event Type describing the type of event and the format of the data being reported.

Table 98. BIOS Sensor and SEL Data

Sensor Name	Sensor Number	Sensor Owner (GID)	Sensor Type	Event/Reading Type Offset Values	Event Data 2 Event Data 3
Mirroring Redundancy State	01h	33h (SMI Handler)	0Ch (Memory)	0Bh (Discrete, Redundancy State) 0h = Fully Redundant 2h = Redundancy Degraded	ED2 = [7:4] = Mirroring Domain 0-1 = Channel Pair for Socket [3:2] = Reserved [1:0] = Rank on DIMM 0-3 = Rank Number ED3 = [7:5] = Socket ID 0-3 = CPU1-4 [4:3] = Channel 0-3 = Channel A-D for Socket [2:0] = DIMM 0-2 = DIMM 1-3 on Channel

Sensor Name	Sensor Number	Sensor Owner (GID)	Sensor Type	Event/Reading Type Offset Values	Event Data 2 Event Data 3
Memory RAS Configuration Status	02h	01h (BIOS POST)	0Ch (Memory)	09h (Digital Discrete) 0h = RAS Configuration Disabled 1h = RAS Configuration Enabled	ED2 = [7:4] = Reserved [3:0] Config Err 0 = None 3 = Invalid DIMM Config for RAS Mode ED3 = [7:4] = Reserved [3:0] = RAS Mode 0 = None 1 = Mirroring 2 = Lockstep 4 = Rank Sparing
Memory ECC Error	02h	33h (SMI Handler)	0Ch (Memory)	6Fh (Sensor Specific Offset) 0h = Correctable Error 1h = Uncorrectable Error	ED2 = [7:2] = Reserved [1:0] = Rank on DIMM 0-3 = Rank Number ED3 = [7:5] = Socket ID 0-3 = CPU1-4 [4:3] = Channel 0-3 = Channel A-D for Socket [2:0] = DIMM 0-2 = DIMM 1-3 on Channel
Legacy PCI Error	03h	33h (SMI Handler)	13h (Critical Interrupt)	6Fh (Sensor Specific Offset) 4h = PCI PERR 5h = PCI SERR	ED2 = [7:0] = Bus Number ED3 = [7:3] = Device Number [2:0] = Function Number

Sensor Name	Sensor Number	Sensor Owner (GID)	Sensor Type	Event/Reading Type Offset Values	Event Data 2 Event Data 3
PCIe Fatal Error (Standard AER Errors) (see Sensor 14h for continuation)	04h	33h (SMI Handler)	13h (Critical Interrupt)	70h (OEM Discrete) 0h = Data Link Layer Protocol Error 1h = Surprise Link Down Error 2h = Completer Abort 3h = Unsupported Request 4h = Poisoned TLP 5h = Flow Control Protocol 6h = Completion Timeout 7h = Receiver Buffer Overflow 8h = ACS Violation 9h = Malformed TLP Ah = ECRC Error Bh = Received Fatal Message From Downstream Ch = Unexpected Completion Dh = Received ERR_NONFATAL Message Eh = Uncorrectable Internal Fh = MC Blocked TLP	ED2 = [7:0] = Bus Number ED3 = [7:3] = Device Number [2:0] = Function Number
PCIe Correctable Error (Standard AER Errors)	05h	33h (SMI Handler)	13h (Critical Interrupt)	71h (OEM Discrete) 0h = Receiver Error 1h = Bad DLLP 2h = Bad TLP 3h = Replay Num Rollover 4h = Replay Timer timeout 5h = Advisory Non-fatal 6h = Link BW Changed 7h = Correctable Internal 8h = Header Log Overflow	ED2 = [7:0] = Bus Number ED3 = [7:3] = Device Number [2:0] = Function Number
BIOS POST Error	06h	01h (BIOS POST)	0Fh (System Firmware Progress)	6Fh (Sensor Specific Offset) 0h = System Firmware Error (POST Error Code)	ED2 = [7:0] = LSB of POST Error Code ED3 = [7:0] MSB of POST Error Code
QPI Correctable Errors (reserved for Validation)	06h	33h (SMI Handler)	13h (Critical Interrupt)	72h (OEM Discrete) Offset Reserved	ED2 = Reserved ED3 = Reserved
QPI Fatal Error (see Sensor 17h	07h	33h (SMI Handler)	13h (Critical Interrupt)	73h (OEM Discrete) 0h = Link Layer	ED2 = [7:0] = Node ID

Sensor Name	Sensor Number	Sensor Owner (GID)	Sensor Type	Event/Reading Type Offset Values	Event Data 2 Event Data 3
for continuation)				Uncorrectable ECC Error 1h = Protocol Layer Poisoned Packet Reception Error 2h = Link/PHY Init Failure with resultant degradation in link width 3h = CSI PHY Layer detected drift buffer alarm 4h = CSI PHY detected latency buffer rollover 5h = CSI PHY Init Failure 6h = CSI Link Layer generic control error (buffer overflow/underflow, credit underflow and so on.) 7h = Parity error in link or PHY layer 8h = Protocol layer timeout detected 9h = Protocol layer failed response Ah = Protocol layer illegal packet field, target Node ID and so on. Bh = Protocol Layer Queue/table overflow/underflow Ch = Viral Error Dh = Protocol Layer parity error Eh = Routing Table Error Fh = (unused)	ED2 = [7:0] = Node ID 0-3 = CPU1-4 ED3 = No Data
Chipset Proprietary (reserved for Validation)	08h	33h (SMI Handler)	19h (Chipset)	75h (OEM Discrete) Offset Reserved	ED2 = Reserved ED3 = Reserved
QPI Link Width Reduced	09h	01h (BIOS POST)	13h (Critical Interrupt)	77h (OEM Discrete) 1h = Reduced to ½ width 2h = Reduced to ¼ width	ED2 = [7:0] = Node ID 0-3 = CPU1-4 ED3 = No Data
Memory Error Extension (reserved for Validation)	10h	33h (SMI Handler)	0Ch (Memory)	7Fh (OEM Discrete) Offset Reserved	ED2 = Reserved ED3 = Reserved

Sensor Name	Sensor Number	Sensor Owner (GID)	Sensor Type	Event/Reading Type Offset Values	Event Data 2 Event Data 3
Sparing Redundancy State	11h	33h (SMI Handler)	0Ch (Memory)	0Bh (Discrete, Redundancy State) 0h = Fully Redundant 2h = Redundancy Degraded	ED2 = [7:4] = Sparing Domain 0-3 = Channel A-D for Socket [3:2] = Reserved [1:0] = Rank on DIMM 0-3 = Rank Number ED3 = [7:5]= Socket ID 0-3 = CPU1-4 [4:3] = Channel 0-3 = Channel A-D for Socket [2:0] = DIMM 0-2 = DIMM 1-3 on Channel
Memory RAS Mode Select	12h	01h (BIOS POST)	0Ch (Memory)	09h (Digital Discrete) 0h = RAS Configuration Disabled 1h = RAS Configuration Enabled	ED2 = Prior Mode [7:4] = Reserved [3:0] = RAS Mode 0 = None 1 = Mirroring 2 = Lockstep 4 = Rank Sparing ED3 = Selected Mode [7:4] = Reserved [3:0] = RAS Mode 0 = None 1 = Mirroring 2 = Lockstep 4 = Rank Sparing

Sensor Name	Sensor Number	Sensor Owner (GID)	Sensor Type	Event/Reading Type Offset Values	Event Data 2 Event Data 3
Memory Parity Error	13h	33h (SMI Handler)	0Ch (Memory)	6Fh (Sensor Specific Offset) 2h = Address Parity Error	ED2 = Validity [7:5] = Reserved [4] = Channel Validity Check 0 = ED3 Chan # Not Valid 1 = ED3 Chan # Is Valid [3] = DIMM Validity Check 0 = ED3 DIMM # Not Valid 1 = ED3 DIMM # Is Valid [2:0] = Error Type 0 = Not Known 2 = Address Parity Error ED3 = Location [7:5]= Socket ID 0-3 = CPU1-4 [4:2] = Channel 0-3 = Channel A-D for Socket [1:0] = DIMM 0-2 = DIMM 1-3 on Channel
PCIe Fatal Error#2 (Standard AER Errors) (continuation of Sensor 04h)	14h	33h (SMI Handler)	13h (Critical Interrupt)	76h (OEM Discrete) 0h = Atomic Egress Blocked 1h = TLP Prefix Blocked Fh = Unspecified Non-AER Fatal Error	ED2 = [7:0] = Bus Number ED3 = [7:3] = Device Number [2:0] = Function Number

Sensor Name	Sensor Number	Sensor Owner (GID)	Sensor Type	Event/Reading Type Offset Values	Event Data 2 Event Data 3
QPI Fatal Error (continuation of <u>Sensor 07h</u>)	17h	33h (SMI Handler)	13h (Critical Interrupt)	74h (OEM Discrete) 0h = Illegal inbound request 1h = IIO Write Cache Uncorrectable Data ECC Error 2h = IIO CSR crossing 32-bit boundary Error 3h = IIO Received XPF physical/logical redirect interrupt inbound 4h = IIO Illegal SAD or Illegal or non-existent address or memory 5h = IIO Write Cache Coherency Violation 6Fh (Sensor Specific Offset) 1h = System Boot Event 5h = Time Synch (EPSD)	ED2 = [7:0] = Node ID 0-3 = CPU1-4 ED3 = No Data
System Event	83h	01h (BIOS POST)	12h (System Event))	6Fh (Sensor Specific Offset) 5h = Time Synch (EPSD)	ED2 = (only for Time Synch) [7:0] Synch # 00h = 1 st in pair 80h = 2 nd in pair ED3 = No Data
System Event	83h	33h (SMI Handler)	12h (System Event))	6Fh (Sensor Specific Offset) 5h = Time Synch (EPSD)	ED2 = (only for Time Synch) [7:0] Synch # 00h = 1 st in pair 80h = 2 nd in pair ED3 = No Data

Appendix D: POST Code LED Decoder

During the system boot process, the BIOS executes several platform configuration processes, each of which is assigned a specific hex POST code number. As each configuration routine is started, the BIOS displays the POST code on the POST code diagnostic LEDs found on the back edge of the server board. To assist in troubleshooting a system hang during the POST process, the diagnostic LEDs can be used to identify the last POST process to be executed.

Each POST code is represented by the eight amber diagnostic LEDs. The POST codes are divided into two nibbles, an upper nibble and a lower nibble. The upper nibble bits are represented by diagnostic LEDs #4, #5, #6, and #7. The lower nibble bits are represented by diagnostics LEDs #0, #1, #2, and #3. If the bit is set in the upper and lower nibbles, then the corresponding LED is lit. If the bit is clear, then the corresponding LED is off.

The diagnostic LED #7 is labeled as “MSB” (Most Significant Bit), and the diagnostic LED #0 is labeled as “LSB” (Least Significant Bit).

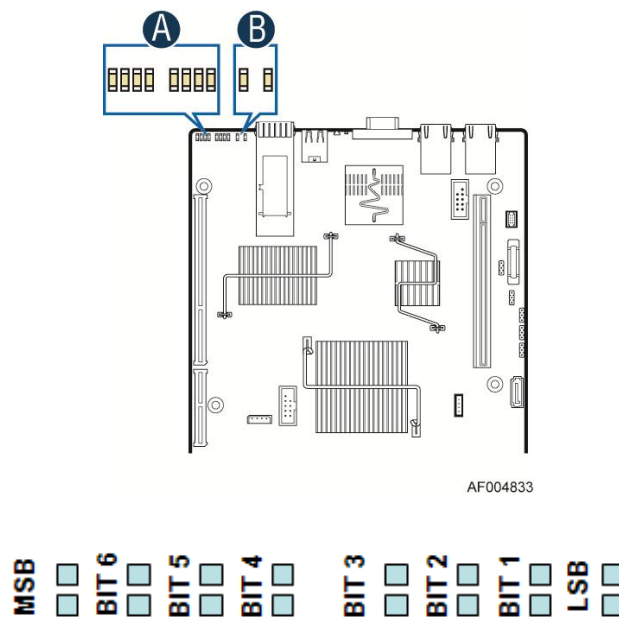

Figure 53. Diagnostic LED Placement Diagram

In the following example, the BIOS sends a value of ACh to the diagnostic LED decoder. The LEDs are decoded as follows:

Table 99. POST Progress Code LED Example

LEDs	Upper Nibble LEDs				Lower Nibble LEDs			
	MSB							LSB
	LED #7	LED #6	LED #5	LED #4	LED #3	LED #2	LED #1	LED #0
	8h	4h	2h	1h	8h	4h	2h	1h
Status	ON	OFF	ON	OFF	ON	ON	OFF	OFF
Results	1	0	1	0	1	1	0	0
	Ah				Ch			

Upper nibble bits = 1010b = Ah; Lower nibble bits = 1100b = Ch; the two are concatenated as ACh.

Table 100. Diagnostic LED POST Code Decoder

Checkpoint	Diagnostic LED Decoder								Description
	1 = On, 0=Off								
	Upper Nibble				Lower Nibble				
	MSB							LSB	
LED	#7	#6	#5	#4	#3	#2	#1	#0	
Host Processor									
0x10h	0	0	0	1	0	0	0	0	Power-on initialization of the host processor (bootstrap processor)
0x11h	0	0	0	1	0	0	0	1	Host processor cache initialization (including AP)
0x12h	0	0	0	1	0	0	1	0	Starting application processor initialization
0x13h	0	0	0	1	0	0	1	1	SMM initialization
0x14h	0	0	0	1	0	1	0	0	Selection of Processor with least features to be used as Boot Strap Processor
0x15h	0	0	0	1	0	1	0	1	Switch an AP processor to become the new Boot Strap Processor
Chipset									
0x21h	0	0	1	0	0	0	0	1	Initializing a chipset component
Memory									
0x22h	0	0	1	0	0	0	1	0	Reading configuration data from memory (SPD on FBDIMM)
0x23h	0	0	1	0	0	0	1	1	Detecting presence of memory
0x24h	0	0	1	0	0	1	0	0	Programming timing parameters in the memory controller
0x25h	0	0	1	0	0	1	0	1	Configuring memory parameters in the memory controller
0x26h	0	0	1	0	0	1	1	0	Optimizing memory controller settings
0x27h	0	0	1	0	0	1	1	1	Initializing memory, such as ECC init
0x28h	0	0	1	0	1	0	0	0	Testing memory
0xE4h	1	1	1	0	0	1	0	0	BIOS cannot communicate with DIMM (serial channel hardware failure)
0xE6h	1	1	1	0	0	1	1	0	DIMM(s) failed Memory iBIST or Memory Link Training failure
0xE8h	1	1	1	0	1	0	0	0	No memory available (system halted)
0xE9h	1	1	1	0	1	0	0	1	Unsupported or invalid DIMM configuration (system halted)
0xEAh	1	1	1	0	1	0	1	0	DIMM training sequence failed (system halted)
0xEBh	1	1	1	0	1	0	1	1	Memory test failed (system halted)
0xECh	1	1	1	0	1	1	0	0	Unsupported or invalid DIMM configuration (system halted)
0xEDh	1	1	1	0	1	1	0	1	Unsupported or invalid DIMM configuration (system halted)
0xEBh	1	1	1	0	1	0	1	1	DIMM with corrupted SPD data detected (system halted)

QuickPath Interconnect (QPI)									
0xA0h	1	0	1	0	0	0	0	0	QPI Initialization
0xA1h	1	0	1	0	0	0	0	1	QPI Initialization
0xA2h	1	0	1	0	0	0	1	0	QPI Initialization
0xA3h	1	0	1	0	0	0	1	1	QPI Initialization
0xA4h	1	0	1	0	0	1	0	0	QPI Initialization
0xA5h	1	0	1	0	0	1	0	1	QPI Initialization
0xA6h	1	0	1	0	0	1	1	0	QPI Initialization
0xA7h	1	0	1	0	0	1	1	1	QPI Initialization
0xA8h	1	0	1	0	1	0	0	0	QPI Initialization
0xA9h	1	0	1	0	1	0	0	1	QPI Initialization
0xAAh	1	0	1	0	1	0	1	0	QPI Initialization
0xABh	1	0	1	0	1	0	1	1	QPI Initialization
0xACh	1	0	1	0	1	1	0	0	QPI Initialization
0xADh	1	0	1	0	1	1	0	1	QPI Initialization
0xAEh	1	0	1	0	1	1	1	0	QPI Initialization
0xAFh	1	0	1	0	1	1	1	1	QPI Initialization
Integrated Memory Controller (IMC)									
0xB0h	1	0	1	1	0	0	0	0	Memory Initialization of Integrated Memory Controller
0xB1h	1	0	1	1	0	0	0	1	Memory Initialization of Integrated Memory Controller
0xB2h	1	0	1	1	0	0	1	0	Memory Initialization of Integrated Memory Controller
0xB3h	1	0	1	1	0	0	1	1	Memory Initialization of Integrated Memory Controller
0xB4h	1	0	1	1	0	1	0	0	Memory Initialization of Integrated Memory Controller
0xB5h	1	0	1	1	0	1	0	1	Memory Initialization of Integrated Memory Controller
0xB6h	1	0	1	1	0	1	1	0	Memory Initialization of Integrated Memory Controller
0xB7h	1	0	1	1	0	1	1	1	Memory Initialization of Integrated Memory Controller
0xB8h	1	0	1	1	1	0	0	0	Memory Initialization of Integrated Memory Controller
0xB9h	1	0	1	1	1	0	0	1	Memory Initialization of Integrated Memory Controller
0xBAh	1	0	1	1	1	0	1	0	Memory Initialization of Integrated Memory Controller
0xBBh	1	0	1	1	1	0	1	1	Memory Initialization of Integrated Memory Controller
0xBCh	1	0	1	1	1	1	0	0	Memory Initialization of Integrated Memory Controller
0xBDh	1	0	1	1	1	1	0	1	Memory Initialization of Integrated Memory Controller
0xBEh	1	0	1	1	1	1	1	0	Memory Initialization of Integrated Memory Controller
0xBFh	1	0	1	1	1	1	1	1	Memory Initialization of Integrated Memory Controller
PCI Bus									
0x50h	0	1	0	1	0	0	0	0	Enumerating PCI buses
0x51h	0	1	0	1	0	0	0	1	Allocating resources to PCI buses
0x52h	0	1	0	1	0	0	1	0	Hot Plug PCI controller initialization
0x53h	0	1	0	1	0	0	1	1	Reserved for PCI bus
0x54h	0	1	0	1	0	1	0	0	Reserved for PCI bus
0x55h	0	1	0	1	0	1	0	1	Reserved for PCI bus

USB									
0x56h	0	1	0	1	0	1	1	0	Initializing USB host controllers
0x57h	0	1	0	1	0	1	1	1	Detecting USB devices
0x58h	0	1	0	1	1	0	0	0	Resetting USB bus
0x59h	0	1	0	1	1	0	0	1	Reserved for USB devices
ATA/ATAPI/SATA									
0x5Ah	0	1	0	1	1	0	1	0	Resetting SATA bus and all devices
0x5Bh	0	1	0	1	1	0	1	1	Detecting the presence of ATA device
0x5Ch	0	1	0	1	1	1	0	0	Enable SMART if supported by ATA device
0x5Dh	0	1	0	1	1	1	0	1	Reserved for ATA
SMBUS*									
0x5Eh	0	1	0	1	1	1	1	0	Resetting SMBUS*
0x5Fh	0	1	0	1	1	1	1	1	Reserved for SMBUS*
I/O Controller Hub									
0x61h	0	1	1	0	0	0	0	1	Initializing I/O Controller Hub
Super I/O									
0x63h	0	1	1	0	0	0	1	1	Initializing Super I/O
Local Console									
0x70h	0	1	1	1	0	0	0	0	Resetting the video controller (VGA)
0x71h	0	1	1	1	0	0	0	1	Disabling the video controller (VGA)
0x72h	0	1	1	1	0	0	1	0	Enabling the video controller (VGA)
0x73h	0	1	1	1	0	0	1	1	Reserved for video controller (VGA)
Remote Console									
0x78h	0	1	1	1	1	0	0	0	Resetting the console controller
0x79h	0	1	1	1	1	0	0	1	Disabling the console controller
0x7Ah	0	1	1	1	1	0	1	0	Enabling the console controller
0x7Bh	0	1	1	1	1	0	1	1	Reserved for console controller
Keyboard (only USB)									
0x90h	1	0	0	1	0	0	0	0	Resetting the keyboard
0x91h	1	0	0	1	0	0	0	1	Disabling the keyboard
0x92h	1	0	0	1	0	0	1	0	Detecting the presence of the keyboard
0x93h	1	0	0	1	0	0	1	1	Enabling the keyboard
0x94h	1	0	0	1	0	1	0	0	Clearing keyboard input buffer
0x96h	1	0	0	1	0	1	1	0	Reserved for keyboard
Mouse (only USB)									
0x98h	1	0	0	1	0	0	1	0	Resetting the mouse
0x99h	1	0	0	1	0	0	1	1	Detecting the mouse
0x9Ah	1	0	0	1	0	1	1	0	Detecting the presence of mouse
0x9Bh	1	0	0	1	0	1	1	1	Enabling the mouse
0x9Ch	1	0	0	1	0	0	1	0	Reserved for mouse
Serial Port									
0xA8h	1	0	1	0	1	0	0	0	Resetting the serial port
0xA9h	1	0	1	0	1	0	0	1	Disabling the serial port
0xAAh	1	0	1	0	1	0	1	0	Detecting the presence of the serial port
0xABh	1	0	1	0	1	0	1	1	Clearing serial port buffer
0xACh	1	0	1	0	1	1	0	0	Enabling serial port
0xADh	1	0	1	0	1	1	0	1	Reserved for serial port

Fixed Media									
0xB0h	1	0	1	1	0	0	0	0	Resetting fixed media device
0xB1h	1	0	1	1	0	0	0	1	Disabling fixed media device
0xB2h	1	0	1	1	0	0	1	0	Detecting presence of a fixed media device (SATA hard drive detection, and so forth)
0xB3h	1	0	1	1	0	0	1	1	Enabling/configuring a fixed media device
0xB4h	1	0	1	1	0	1	0	0	Reserved for fixed media
Removable Media									
0xB8h	1	0	1	1	1	0	0	0	Resetting removable media device
0xB9h	1	0	1	1	1	0	0	1	Disabling removable media device
0xBAh	1	0	1	1	1	0	1	0	Detecting presence of a removable media device (SATA CDROM detection, and so forth)
0xBC	1	0	1	1	1	1	0	0	Enabling/configuring a removable media device
0xBDh	1	0	1	1	1	1	0	1	Reserved for removable media device
Boot Device Selection (BDS)									
0xD0	1	1	0	1	0	0	0	0	Entered the Boot Device Selection phase (BDS)
0xD1	1	1	0	1	0	0	0	1	Return to last good boot device
0xD2	1	1	0	1	0	0	1	0	Setup boot device selection policy
0xD3	1	1	0	1	0	0	1	1	Connect boot device controller
0xD4	1	1	0	1	0	1	0	0	Attempt flash update boot mode
0xD5	1	1	0	1	0	1	0	1	Transfer control to EFI boot
0xD6	1	1	0	1	0	1	1	0	Trying to boot device selection
0xDF	1	1	0	1	1	1	1	1	Reserved for boot device selection
Pre-EFI Initialization (PEI) Core									
0xE0h	1	1	1	0	0	0	0	0	Entered Pre-EFI Initialization phase (PEI)
0xE1h	1	1	1	0	0	0	0	1	Started dispatching early initialization modules (PEIM)
0xE2h	1	1	1	0	0	0	1	0	Initial memory found, configured, and installed correctly
0xE3h	1	1	1	0	0	0	1	1	Transfer control to the DXE Core
PEI Modules									
0xF0h	1	1	1	1	0	0	0	0	Install PEIM for Platform Status Codes
0xF1h	1	1	1	1	0	0	0	1	Detecting Platform Type
0xF2h	1	1	1	1	0	0	1	0	Early Platform Initialization
0xF3h	1	1	1	1	0	0	1	1	PEI Modules initialized
Driver eXecution Environment (DXE) Core									
0xE4h	1	1	1	0	0	1	0	0	Entered EFI driver execution phase (DXE)
0xE5h	1	1	1	0	0	1	0	1	Started dispatching drivers
0xE6h	1	1	1	0	0	1	1	0	Started connecting drivers
DXE Drivers									
0xE7h	1	1	1	0	1	1	0	1	Waiting for user input
0xE8h	1	1	1	0	1	0	0	0	Checking password
0xE9h	1	1	1	0	1	0	0	1	Entering BIOS setup
0xEAh	1	1	1	0	1	1	0	0	Flash Update
0xEBh	1	1	1	0	1	1	0	1	Legacy Option ROM initialization
0xECh	1	1	1	0	1	0	0	0	DXE Drivers initialized
0xEDh	1	1	1	0	1	0	0	1	Transfer control to Boot Device Selection (BDS)
0xEEh	1	1	1	0	1	1	0	0	Calling Int 19. One beep unless silent boot is enabled.
0xEFh	1	1	1	0	1	1	0	1	Unrecoverable boot failure

Pre-EFI Initialization Module (PEIM)/Recovery									
0x30h	0	0	1	1	0	0	0	0	Crisis recovery initiated because of a user request
0x31h	0	0	1	1	0	0	0	1	Crisis recovery initiated by software (corrupt flash)
0x34h	0	0	1	1	0	1	0	0	Loading crisis recovery capsule
0x35h	0	0	1	1	0	1	0	1	Handing off control to the crisis recovery capsule
0x36h	0	0	1	1	0	1	1	0	Begin crisis recovery
0x3Eh	0	0	1	1	1	1	1	0	No crisis recovery capsule detected
0x3Fh	0	0	1	1	1	1	1	1	Crisis recovery capsule failed integrity check of capsule descriptors

Appendix E: Video POST Code Errors

Whenever possible, the BIOS outputs the current boot progress codes on the video screen. Progress codes are 32-bit quantities plus optional data. The 32-bit numbers include class, subclass, and operation information. The class and subclass fields point to the type of hardware being initialized. The operation field represents the specific initialization activity. Based on the data bit availability to display progress codes, a progress code can be customized to fit the data width. The higher the data bit, the higher the granularity of information that can be sent on the progress port. The progress codes may be reported by the system BIOS or option ROMs.

The Response section in the following table is divided into three types:

- **No Pause:** The message is displayed on the local Video screen during POST or in the Error Manager. The system continues booting with a degraded state. The user may want to replace the erroneous unit. The setup POST error Pause setting does not have any effect with this error.
- **Pause:** The message is displayed on the Error Manager screen, and an error is logged to the SEL. The setup POST error Pause setting determines whether the system pauses to the Error Manager for this type of error, where the user can take immediate corrective action or choose to continue booting.
- **Halt:** The message is displayed on the Error Manager screen, an error is logged to the SEL, and the system cannot boot unless the error is resolved. The user needs to replace the faulty part and restart the system. The setup POST error Pause setting does not have any effect with this error.

Table 101. POST Error Messages and Handling

Error Code	Error Message	Response
0012	CMOS date/time not set	Major
0048	Password check failed	Major
0108	Keyboard component encountered a locked error.	Minor
0109	Keyboard component encountered a stuck key error.	Minor
0113	Fixed Media The SAS RAID firmware cannot run properly. The user should attempt to reflash the firmware.	Major
0140	PCI component encountered a PERR error.	Major
0141	PCI resource conflict	Major
0146	PCI out of resources error	Major
0192	Processor 0x cache size mismatch detected.	Fatal
0193	Processor 0x stepping mismatch.	Minor
0194	Processor 0x family mismatch detected.	Fatal
0195	Processor 0x Intel® QPI speed mismatch.	Major
0196	Processor 0x model mismatch.	Fatal
0197	Processor 0x speeds mismatched.	Fatal
0198	Processor 0x family is not supported.	Fatal
019F	Processor and chipset stepping configuration is unsupported.	Major
5220	CMOS/NVRAM Configuration Cleared	Major
5221	Passwords cleared by jumper	Major
5224	Password clear Jumper is Set.	Major

Error Code	Error Message	Response
8160	Processor 01 unable to apply microcode update	Major
8161	Processor 02 unable to apply microcode update	Major
8180	Processor 0x microcode update not found.	Minor
8190	Watchdog timer failed on last boot	Major
8198	OS boot watchdog timer failure.	Major
8300	Baseboard management controller failed self-test	Major
84F2	Baseboard management controller failed to respond	Major
84F3	Baseboard management controller in update mode	Major
84F4	Sensor data record empty	Major
84FF	System event log full	Minor
8500	Memory component could not be configured in the selected RAS mode.	Major
8501	DIMM Population Error.	Major
8502	CLTT Configuration Failure Error.	Major
8520	DIMM_A1 failed Self-Test (BIST).	Major
8521	DIMM_A2 failed Self-Test (BIST).	Major
8522	DIMM_B1 failed Self-Test (BIST).	Major
8523	DIMM_B2 failed Self-Test (BIST).	Major
8524	DIMM_C1 failed Self-Test (BIST).	Major
8525	DIMM_C2 failed Self-Test (BIST).	Major
8526	DIMM_D1 failed Self-Test (BIST).	Major
8527	DIMM_D2 failed Self-Test (BIST).	Major
8528	DIMM_E1 failed Self-Test (BIST).	Major
8529	DIMM_E2 failed Self-Test (BIST).	Major
852A	DIMM_F1 failed Self-Test (BIST).	Major
852B	DIMM_F2 failed Self-Test (BIST).	Major
8540	DIMM_A1 Disabled.	Major
8541	DIMM_A2 Disabled.	Major
8542	DIMM_B1 Disabled.	Major
8543	DIMM_B2 Disabled.	Major
8544	DIMM_C1 Disabled.	Major
8545	DIMM_C2 Disabled.	Major
8546	DIMM_D1 Disabled.	Major
8547	DIMM_D2 Disabled.	Major
8548	DIMM_E1 Disabled.	Major
8549	DIMM_E2 Disabled.	Major
854A	DIMM_F1 Disabled.	Major
854B	DIMM_F2 Disabled.	Major
8560	DIMM_A1 Component encountered a Serial Presence Detection (SPD) fail error.	Major
8561	DIMM_A2 Component encountered a Serial Presence Detection (SPD) fail error.	Major
8562	DIMM_B1 Component encountered a Serial Presence Detection (SPD) fail error.	Major
8563	DIMM_B2 Component encountered a Serial Presence Detection (SPD) fail error.	Major

Error Code	Error Message	Response
8564	DIMM_C1 Component encountered a Serial Presence Detection (SPD) fail error.	Major
8565	DIMM_C2 Component encountered a Serial Presence Detection (SPD) fail error.	Major
8566	DIMM_D1 Component encountered a Serial Presence Detection (SPD) fail error.	Major
8567	DIMM_D2 Component encountered a Serial Presence Detection (SPD) fail error.	Major
8568	DIMM_E1 Component encountered a Serial Presence Detection (SPD) fail error.	Major
8569	DIMM_E2 Component encountered a Serial Presence Detection (SPD) fail error.	Major
856A	DIMM_F1 Component encountered a Serial Presence Detection (SPD) fail error.	Major
856B	DIMM_F2 Component encountered a Serial Presence Detection (SPD) fail error.	Major
85A0	DIMM_A1 Uncorrectable ECC error encountered.	Major
85A1	DIMM_A2 Uncorrectable ECC error encountered.	Major
85A2	DIMM_B1 Uncorrectable ECC error encountered.	Major
85A3	DIMM_B2 Uncorrectable ECC error encountered.	Major
85A4	DIMM_C1 Uncorrectable ECC error encountered.	Major
85A5	DIMM_C2 Uncorrectable ECC error encountered.	Major
85A6	DIMM_D1 Uncorrectable ECC error encountered.	Major
85A7	DIMM_D2 Uncorrectable ECC error encountered.	Major
85A8	DIMM_E1 Uncorrectable ECC error encountered.	Major
85A9	DIMM_E2 Uncorrectable ECC error encountered.	Major
85AA	DIMM_F1 Uncorrectable ECC error encountered.	Major
85AB	DIMM_F2 Uncorrectable ECC error encountered.	Major
8604	Chipset Reclaim of non-critical variables complete.	Minor
9000	Unspecified processor component has encountered a nonspecific error.	Major
9223	Keyboard component was not detected.	Minor
9226	Keyboard component encountered a controller error.	Minor
9243	Mouse component was not detected.	Minor
9246	Mouse component encountered a controller error.	Minor
9266	Local Console component encountered a controller error.	Minor
9268	Local Console component encountered an output error.	Minor
9269	Local Console component encountered a resource conflict error.	Minor
9286	Remote Console component encountered a controller error.	Minor
9287	Remote Console component encountered an input error.	Minor
9288	Remote Console component encountered an output error.	Minor
92A3	Serial port component was not detected	Major
92A9	Serial port component encountered a resource conflict error	Major
92C6	Serial Port controller error	Minor
92C7	Serial Port component encountered an input error.	Minor
92C8	Serial Port component encountered an output error.	Minor
94C6	LPC component encountered a controller error.	Minor

Error Code	Error Message	Response
94C9	LPC component encountered a resource conflict error.	Major
9506	ATA/ATPI component encountered a controller error.	Minor
95A6	PCI component encountered a controller error.	Minor
95A7	PCI component encountered a read error.	Minor
95A8	PCI component encountered a write error.	Minor
9609	Unspecified software component encountered a start error.	Minor
9641	PEI Core component encountered a load error.	Minor
9667	PEI module component encountered a illegal software state error.	Fatal
9687	DXE core component encountered a illegal software state error.	Fatal
96A7	DXE boot services driver component encountered a illegal software state error.	Fatal
96AB	DXE boot services driver component encountered invalid configuration.	Minor
96E7	SMM driver component encountered an illegal software state error.	Fatal
0xA000	TPM device not detected.	Minor
0xA001	TPM device missing or not responding.	Minor
0xA002	TPM device failure.	Minor
0xA003	TPM device failed self-test.	Minor
0xA022	Processor component encountered a mismatch error.	Major
0xA027	Processor component encountered a low voltage error.	Minor
0xA028	Processor component encountered a high voltage error.	Minor
0xA421	PCI component encountered a SERR error.	Fatal
0xA500	ATA/ATPI ATA bus SMART not supported.	Minor
0xA501	ATA/ATPI ATA SMART is disabled.	Minor
0xA5A0	PCI Express* component encountered a PERR error.	Minor
0xA5A1	PCI Express* component encountered a SERR error.	Fatal
0xA5A4	PCI Express* IBIST error.	Major
0xA6A0	DXE boot services driver Not enough memory available to shadow a legacy option ROM.	Minor
0xB6A3	DXE boot services driver Unrecognized.	Major

Glossary

This appendix contains important terms used in the preceding chapters. For ease of use, numeric entries are listed first (for example, “82460GX”) with alpha entries following (for example, “AGP 4x”). Acronyms are then entered in their respective place, with non-acronyms following.

Table 102. Glossary

Term	Definition
ACPI	Advanced Configuration and Power Interface
AP	Application Processor
APIC	Advanced Programmable Interrupt Control
ARP	Address Resolution Protocol
ASIC	Application Specific Integrated Circuit
BIOS	Basic Input/Output System
BIST	Built-In Self Test
BMC	Baseboard Management Controller
Bridge	Circuitry connecting one computer bus to another, allowing an agent on one to access the other
BSP	Bootstrap Processor
Byte	8-bit quantity.
CATERR	On a catastrophic hardware event the core signals CATERR to the uncore. The core enters a halted state that can only be exited by a reset.
CBC	Chassis Bridge Controller (A microcontroller connected to one or more other CBCs, together they bridge the IPMB buses of multiple chassis.)
CEK	Common Enabling Kit
CHAP	Challenge Handshake Authentication Protocol
CMOS	In terms of this specification, this describes the PC-AT compatible region of battery-backed 128 bytes of memory, which normally resides on the server board.
DCMI	Data Center Management Interface
DHCP	Dynamic Host Configuration Protocol
DPC	Direct Platform Control
EEPROM	Electrically Erasable Programmable Read-Only Memory
EHCI	Enhanced Host Controller Interface
EMP	Emergency Management Port
EPS	External Product Specification
FBD	Fully Buffered DIMM
F MB	Flexible Mother Board
FRB	Fault Resilient Booting
FRU	Field Replaceable Unit
FSB	Front Side Bus
GB	1024 MB
GPIO	General Purpose I/O
GTL	Gunning Transceiver Logic
GPA	Guest Physical Address
HSC	Hot-Swap Controller

Term	Definition
HPA	Host Physical Address
Hz	Hertz (1 cycle/second)
I2C	Inter-Integrated Circuit Bus
IA	Intel® Architecture
IBF	Input Buffer
ICH	I/O Controller Hub
IC MB	Intelligent Chassis Management Bus
IFB	I/O and Firmware Bridge
ILM	Independent Loading Mechanism
IMC	Integrated Memory Controller
INTR	Interrupt
IP	Internet Protocol
IPMB	Intelligent Platform Management Bus
IPMI	Intelligent Platform Management Interface
IR	Infrared
ITP	In-Target Probe
KB	1024 bytes
KCS	Keyboard Controller Style
LAN	Local Area Network
LCD	Liquid Crystal Display
LED	Light Emitting Diode
LPC	Low Pin Count
LUN	Logical Unit Number
MAC	Media Access Control
MB	1024KB
ME	Management Engine
MD2	Message Digest 2 – Hashing Algorithm
MD5	Message Digest 5 – Hashing Algorithm – Higher Security
ms	Milliseconds
MTTR	Memory Type Range Register
Mux	Multiplexor
NIC	Network Interface Controller
NMI	Nonmaskable Interrupt
OBF	Output Buffer
OEM	Original Equipment Manufacturer
Ohm	Unit of electrical resistance
PECI	Platform Environment Control Interface
PEF	Platform Event Filtering
PEP	Platform Event Paging
PIA	Platform Information Area (This feature configures the firmware for the platform hardware)
PLD	Programmable Logic Device
PMI	Platform Management Interrupt
POST	Power-On Self Test
PSMI	Power Supply Management Interface

Term	Definition
PWM	Pulse-Width Modulation
QPI	QuickPath Interconnect
RAM	Random Access Memory
RASUM	Reliability, Availability, Serviceability, Usability, and Manageability
RISC	Reduced Instruction Set Computing
ROM	Read Only Memory
RTC	Real-Time Clock (Component of ICH peripheral chip on the server board)
RMM3	Remote Management Module 3
SDR	Sensor Data Record
SECC	Single Edge Connector Cartridge
EEPROM	Serial Electrically Erasable Programmable Read-Only Memory
SEL	System Event Log
SIO	Server Input/Output
SMBUS*	System Management BUS
SMI	Server Management Interrupt (SMI is the highest priority nonmaskable interrupt)
SMM	Server Management Mode
SMS	Server Management Software
SNMP	Simple Network Management Protocol
TBD	To Be Determined
TDP	Thermal Design Power
TIM	Thermal Interface Material
UART	Universal Asynchronous Receiver/Transmitter
UDP	User Datagram Protocol
UHCI	Universal Host Controller Interface
URS	Unified Retention System
UTC	Universal time coordinare
UUID	Universally Unique Identifier
VID	Voltage Identification
VRD	Voltage Regulator Down
VT	Virtualization Technology
Word	16-bit quantity
ZIF	Zero Insertion Force

Reference Documents

- ACPI 3.0: <http://www.acpi.info/spec.htm>
- IPMI 2.0
- *Data Center Management Interface Specification v1.0*, May 1, 2008: www.intel.com/go/dcmi
- *PCI Bus Power Management Interface Specification 1.1*: <http://www.pcisig.com/>
- *PCI Express* Base Specification Rev 2.0 Dec 06*: <http://www.pcisig.com/>
- *PCI Express* Card Electromechanical Specification Rev 2.0*: <http://www.pcisig.com/>
- PMBus*: <http://pmbus.org>
- SATA 2.0: <http://www.sata-io.org/>
- SMBIOS 2.4
- SSI-EEB 3.0: <http://www.ssiforum.org>
- USB 1.1: <http://www.usb.org>
- USB 2.0: <http://www.usb.org>
- Windows Logo/SDG 3.0
- *Intel® Dynamic PowerTechnology Node Manager 1.5 External Interface Specification using IPMI, 2007*. Intel Corporation.
- *Node Power and Thermal Management Architecture Specification v1.5, rev.0.79. 2007*, Intel Corporation.
- *Intel® Server System Integrated Baseboard Management Controller Core External Product Specification, 2007* Intel Corporation.
- *Intel® Thurley Server Platform Services IPMI Commands Specification, 2007*. Intel Corporation.
- *Intel® Server Safety and Regulatory, 2011*. Intel Corporation. Order number: G23122-001.
- *Intelligent Platform Management Bus Communications Protocol Specification, Version 1.0, 1998*. Intel Corporation, Hewlett-Packard Company, NEC Corporation, Dell Computer Corporation.
- *Platform Environmental Control Interface (PECI) Specification, Version 2.0*. Intel Corporation.
- *Platform Management FRU Information Storage Definition, Version 1.0, Revision 1.2, 2002*. Intel Corporation, Hewlett-Packard Company, NEC Corporation, Dell Computer Corporation: <http://developer.intel.com/design/servers/ipmi/spec.htm>.