

### 7 Install Optical Drive

1. Remove the Filler Panel
2. Configure Rear of Drive

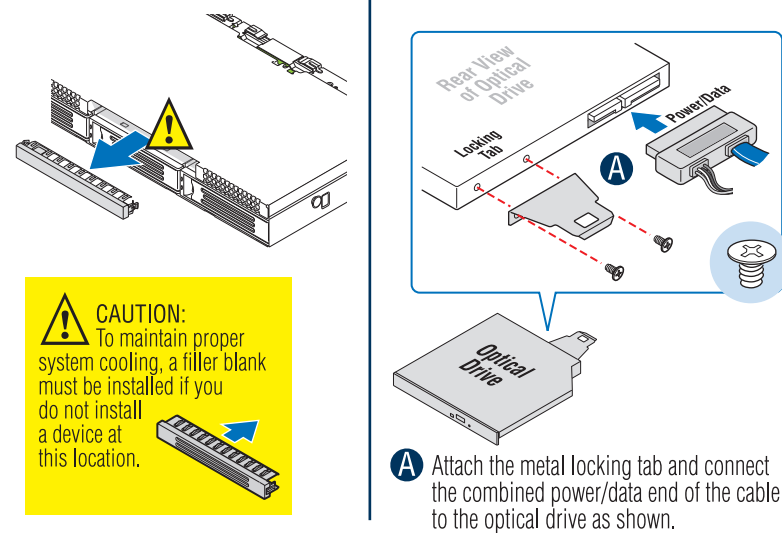

### 3. Install Optical Device Assembly into Chassis

- A Insert the combined power/data cable into the chassis opening, then insert the drive all the way until the latching tab snaps into place.
- B Slide the cables into the cable retention clip on top of the backplane bracket as shown.

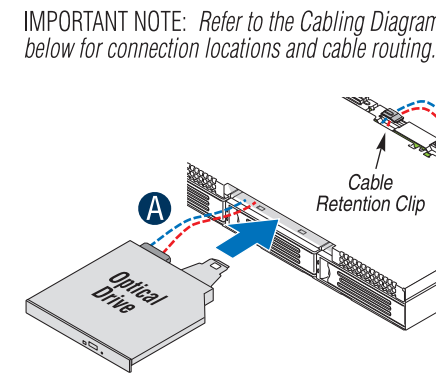

### 8 Install Hard Disk Drives

1. Remove the Drive Carrier
2. Install 2.5' Drive into Carrier

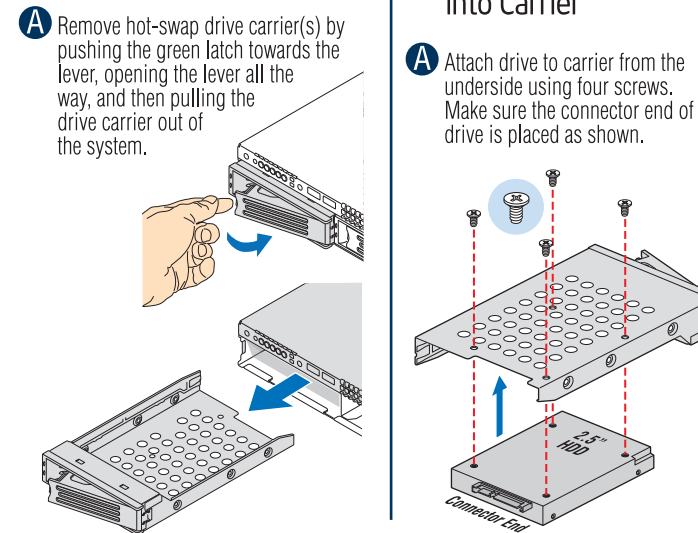

### 3. Install 3.5" Drive into Carrier

- A Attach drive to carrier side rails using four screws. Make sure connector end of drive is placed as shown.

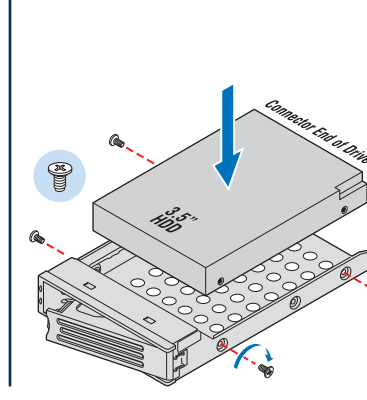

### 4. Install Drive Carrier into Chassis

- A With the carrier lever in the OPEN position, slide drive assembly into chassis until it fully engages the backplane connector, then close the lever until it snaps shut.

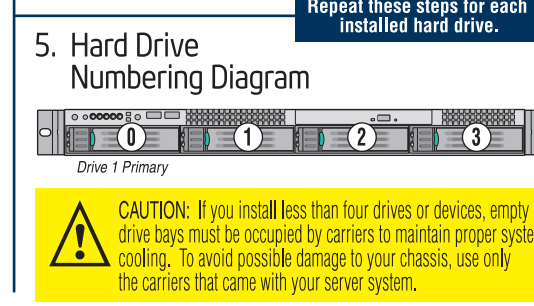

### 5. Hard Drive Numbering Diagram

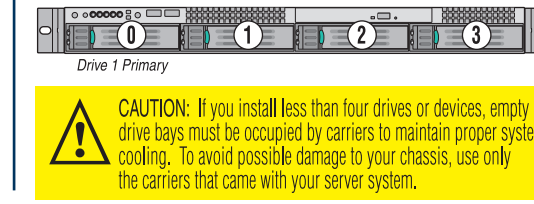

### 9 Install Add-in Card

- A Turn PCIe riser assembly up-side-down for this procedure to avoid damage to the riser card connector.
- B Remove filler panel from the add-in card.
- C Insert add-in card until it seats into the riser card socket.
- D Attach with screw as shown.

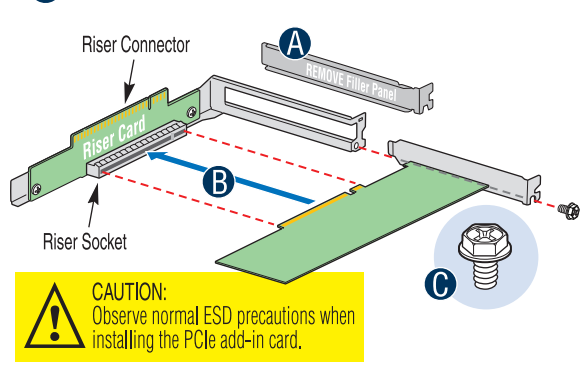

### 10 Install the PCI Riser Assembly

- A Position riser card edge connector over the server board riser socket and align riser with the back panel opening of the chassis.
- B Press down uniformly until the PCI riser assembly engages both the chassis back panel and the riser socket on the server board.

Check that the assembly is flush with the top edges of the chassis.

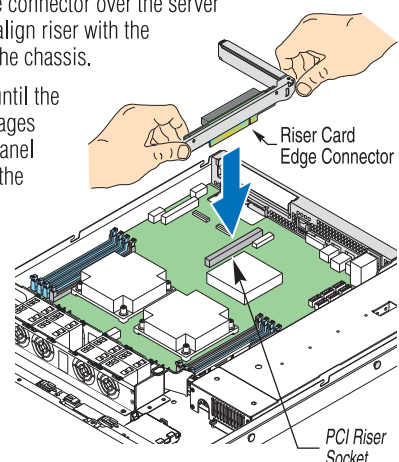

### 11 Install the Air Duct

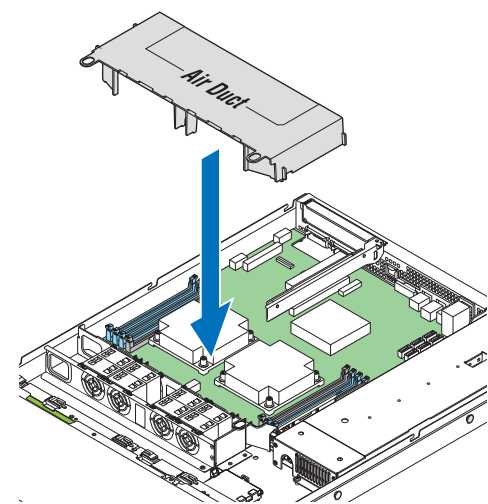

### 12 Install the Top Cover

- A Tighten the captive thumb screw after installation. Replacement of shipping screw is optional.

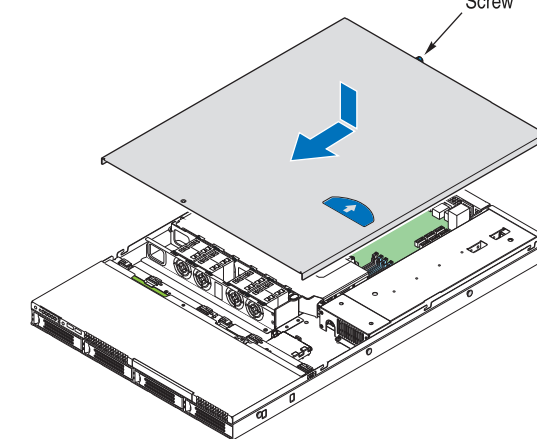

### 13 Install Rack Handles

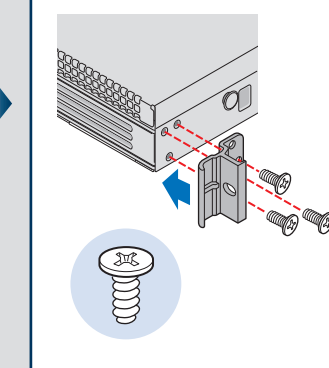

### 14 Finishing Up

Before installing your operating system, you must finish your chassis installation, make I/O connections and plug in power.

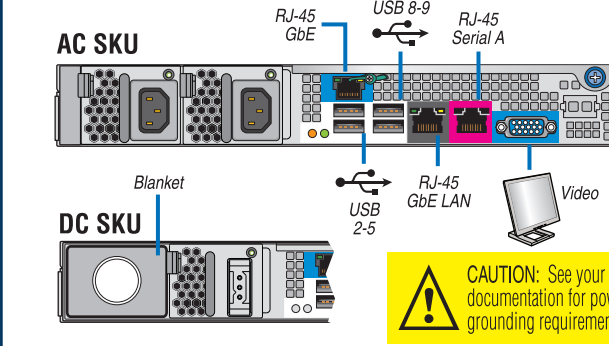

### 15 Software - BIOS, Drivers, and Operating System Installation

- A. **Confirm BIOS Version:** Look on the Server/System Management screen in the BIOS Setup Utility to determine the installed BIOS version. Compare this to the versions at: [http://www.intel.com/p/en\\_US/support/highlights/server/ss-sr1695wb](http://www.intel.com/p/en_US/support/highlights/server/ss-sr1695wb). If new versions are available, update the BIOS on your server. See the Service Guide on the Intel® Server Deployment Toolkit CD for update instructions.
- B. **Configure your RAID Controller:** Use the instructions provided with the RAID controller.
- C. **Install your Operating System:** Use the instructions provided with the RAID controller and with the operating system.
- D. **Install Operating System Drivers:** With the operating system running, insert the Intel® Server Deployment Toolkit CD. If using a Microsoft Windows® operating system, the Intel® Deployment Assistant will autoun and allow you to select the appropriate drivers to install. On other operating systems, browse the CD folders to locate and install the driver files.

### Chassis Fan Connections

See chassis diagram at right for system fan numbering information. To remove fan, first unplug power cable to server board, then lift straight up and remove. When installing new fan, note air flow direction arrow. System airflow is from front to back.

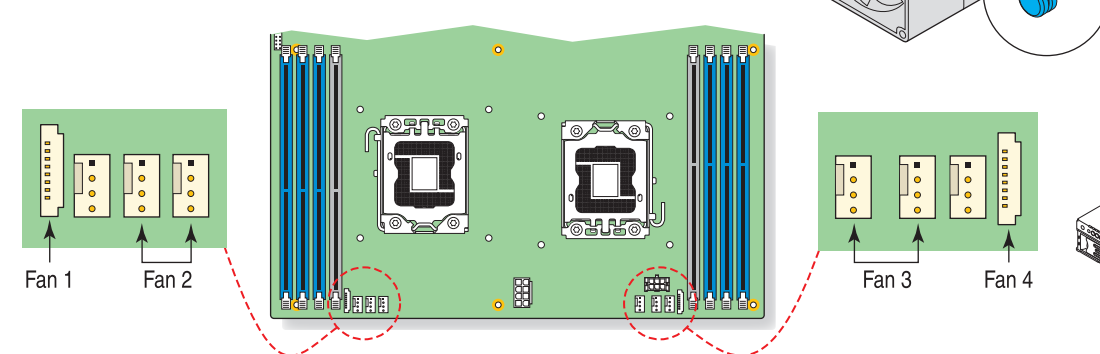

\* See your Server Board S5500WB Product Guide for specific capabilities and configurations for server board system fans.

### Server Board Power Connections

CAUTION: Note the location of the latch on each power cable connector and align it with the matching tab on each server board socket.

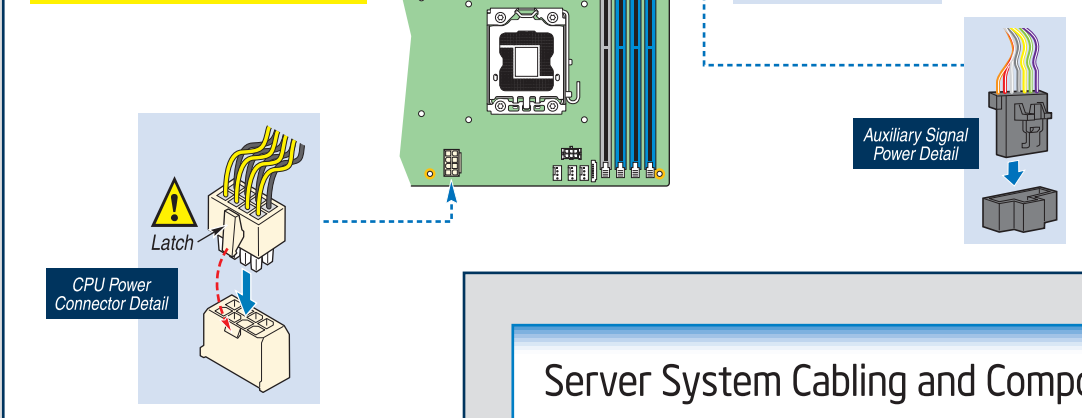

Accessories and Order Codes	
Maintenance Kit: include all cables, front panel/USB board and power distribution board.	FSR1695PMKIT
Spare HDD Carrier	FSR1690HDDCAR
Spare Backplane	FSR1690BP
Spare Fans, include 1 CPU fan and 1 memory fan	FSR1690FAN
Spare AC Power Supply Unit	FTH450WPS
Spare DC Power Supply Unit	ASR1695PSPDC

A complete list of accessories and spares can be found at: [http://www.intel.com/p/en\\_US/support/highlights/server/ss-sr1695wb](http://www.intel.com/p/en_US/support/highlights/server/ss-sr1695wb) (search for the document titled "Spares and Configuration Guide").

Available Documents	
Technical Specification Update	
Quick Reference Label	
Quick Start User Guide	

Additional Reference documents available at: [http://www.intel.com/p/en\\_US/support/highlights/server/ss-sr1695wb](http://www.intel.com/p/en_US/support/highlights/server/ss-sr1695wb)



### Intel® Server Board S5500WB Component Layout

- A Intel® Adaptive Slot 6 functions as either a PCI Express® x16 (x16 lane) Connector or a Riser Card Slot in a 1U Chassis.

Note: Not all components, jumpers and connectors are described in this diagram. Refer to your Server System Service Guide on the Intel® Server Deployment Toolkit CD for additional information.

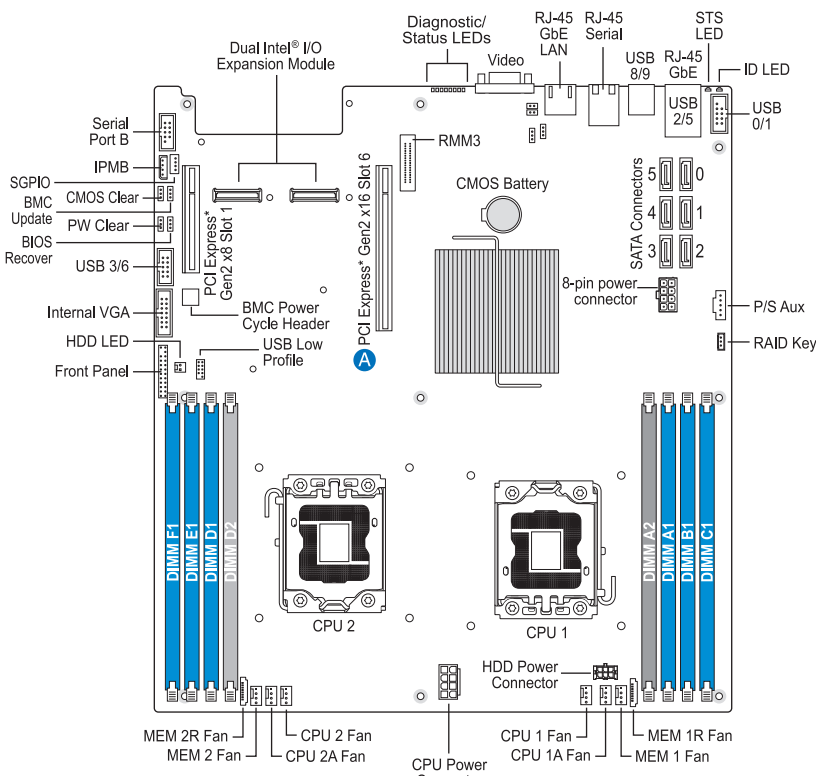

### Front Panel Controls and Indicators

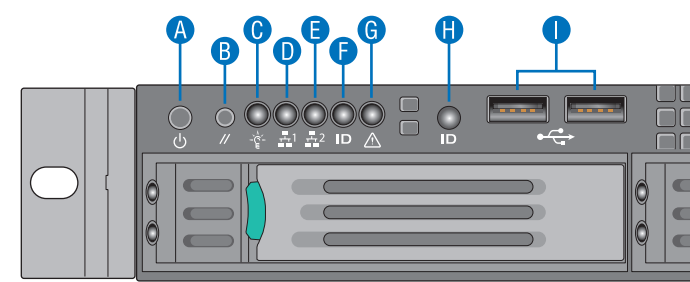

- A. Power/Sleep Button
- B. System Reset Button
- C. Power/Sleep LED
- D. System NIC 1 Activity LED
- E. System NIC 2 Activity LED
- F. System Identification LED
- G. System Status LED
- H. System Identification Button
- I. USB 2.0 Connectors - Port 0/1

### Back Panel Features and Indicators

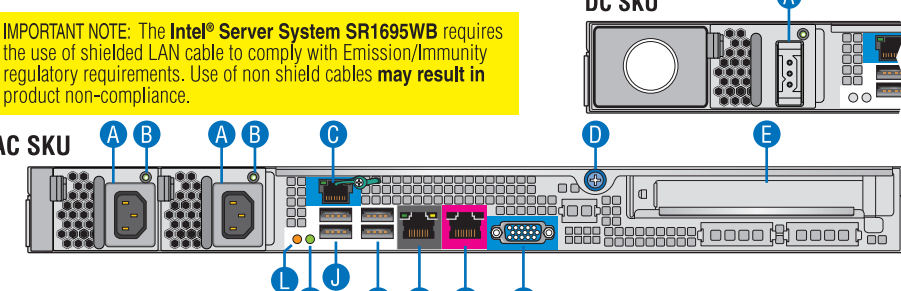

- A. Power IN
- B. PS Status LED
- C. RJ-45 GbE
- D. Thumb Screw
- E. PCIe Add-in Card Slot
- F. Video Out
- G. RJ-45 Serial
- H. RJ-45 GbE
- I. USB 8/9
- J. USB 2/5
- K. STS LED
- L. ID LED

### Server System Cabling and Component Diagram ... Quick Reference

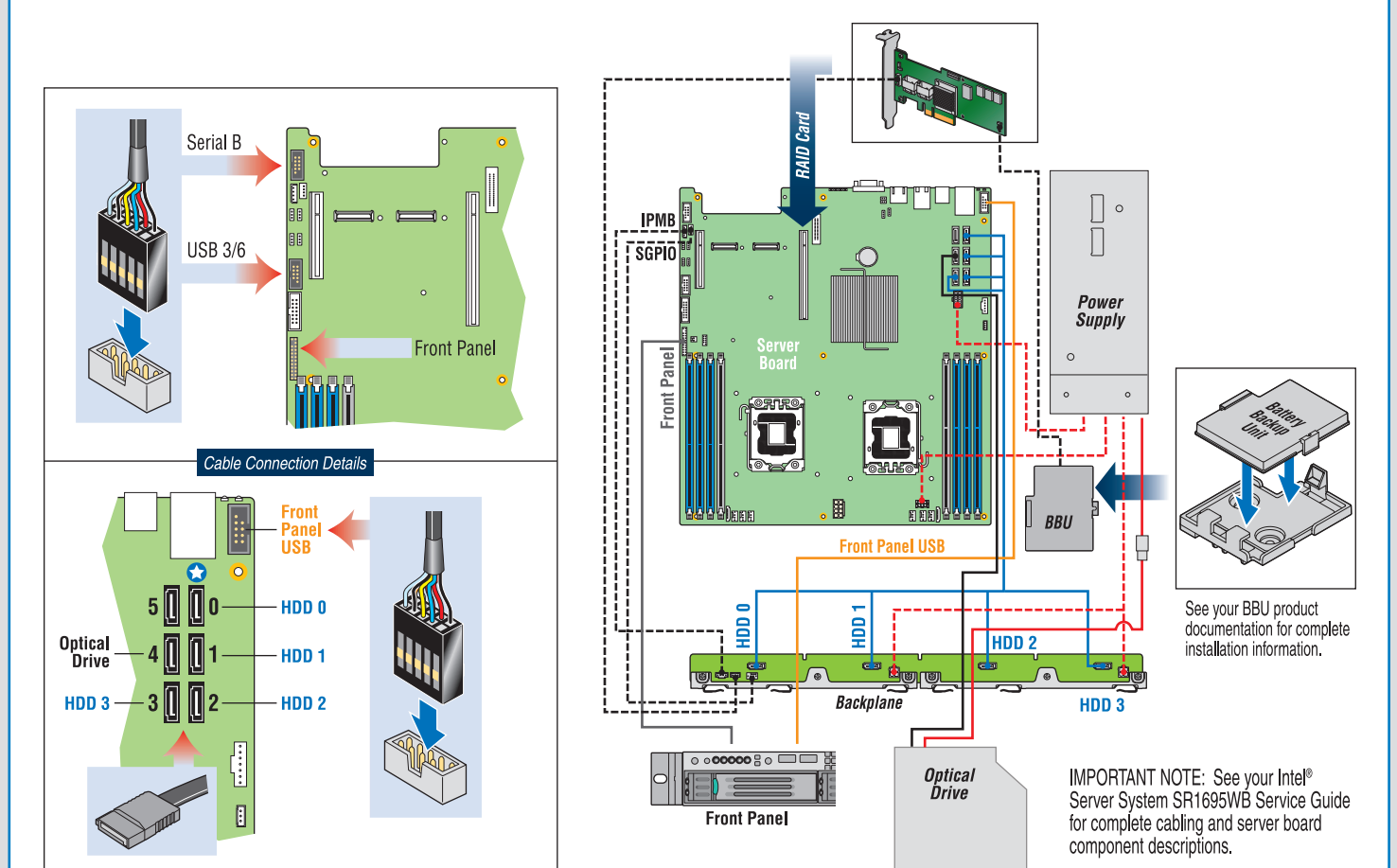

IMPORTANT NOTE: See your Intel® Server System SR1695WB Service Guide for complete cabling and server board component descriptions.