

Intel[®] Carrier Grade Server TIGW1U

Product Guide

April 2008

Rev. 1.2

A Guide for Technically Qualified Assemblers of Intel[®] Identified Subassemblies/Products



INFORMATION IN THIS DOCUMENT IS PROVIDED IN CONNECTION WITH INTEL® PRODUCTS. NO LICENSE, EXPRESS OR IMPLIED, BY ESTOPPEL OR OTHERWISE, TO ANY INTELLECTUAL PROPERTY RIGHTS IS GRANTED BY THIS DOCUMENT. EXCEPT AS PROVIDED IN INTEL'S TERMS AND CONDITIONS OF SALE FOR SUCH PRODUCTS, INTEL ASSUMES NO LIABILITY WHATSOEVER, AND INTEL DISCLAIMS ANY EXPRESS OR IMPLIED WARRANTY, RELATING TO SALE AND/OR USE OF INTEL PRODUCTS INCLUDING LIABILITY OR WARRANTIES RELATING TO FITNESS FOR A PARTICULAR PURPOSE, MERCHANTABILITY, OR INFRINGEMENT OF ANY PATENT, COPYRIGHT OR OTHER INTELLECTUAL PROPERTY RIGHT. Intel products are not intended for use in medical, life saving, life sustaining, critical control or safety systems, or in nuclear facility applications.

Intel may make changes to specifications and product descriptions at any time, without notice.

Intel Corporation may have patents or pending patent applications, trademarks, copyrights, or other intellectual property rights that relate to the presented subject matter. The furnishing of documents and other materials and information does not provide any license, express or implied, by estoppel or otherwise, to any such patents, trademarks, copyrights, or other intellectual property rights.

Intel server boards contain high-density VLSI and power delivery components that need adequate airflow for cooling. Intel's own chassis are designed and tested to meet the intended thermal requirements of these components when the fully integrated system is used together. It is the responsibility of the system integrator that chooses not to use Intel developed server building blocks to consult vendor datasheets and operating parameters to determine the amount of airflow required for their specific application and environmental conditions. Intel Corporation can not be held responsible if components fail or the server board does not operate correctly when used outside any of their published operating or non-operating limits.

Contact your local Intel sales office or your distributor to obtain the latest specifications and before placing your product order.

Copies of documents which have an order number and are referenced in this document, or other Intel literature may be obtained by calling 1-800-548-4725 or by visiting Intel's website at <http://www.intel.com>.

Intel, Intel logo, Intel Core, Xeon, and Xeon Inside are trademarks or registered trademarks of Intel Corporation or its subsidiaries in the United States and other countries.

*Other names and brands may be claimed as the property of others.

Copyright © 2008, Intel Corporation. All Rights Reserved.

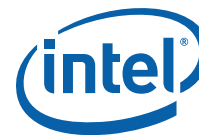


Contents

- 1 Introduction** 9
 - 1.1 About this Manual 9
 - 1.1.1 Manual Organization 9
 - 1.2 What Your Server Includes 9
 - 1.3 Product Accessories 10
 - 1.4 Additional Information and Software 10
- 2 Features** 11
 - 2.1 Server Components 13
 - 2.2 Back Panel 14
 - 2.3 Front Panel 14
 - 2.4 Rear Panel Ethernet Ports 16
 - 2.5 SAS Front Panel (SFP) Board 16
 - 2.5.1 Front Panel Board Features 16
 - 2.6 Server Board Connector and Component Locations 17
 - 2.7 Hard Disk Drives 18
 - 2.8 Riser Card Assembly 18
 - 2.8.1 PCI/PCI-X Riser Card 18
 - 2.8.2 PCI Express Riser Card 19
 - 2.9 Power Supply 19
 - 2.10 System Cooling 19
 - 2.10.1 Front Panel Cooling Area 20
 - 2.10.2 PCI Cooling Area 20
 - 2.10.3 CPU / Memory / HDD Cooling Area 20
 - 2.11 Hardware Requirements 20
 - 2.11.1 Processor 20
 - 2.11.2 Memory 20
- 3 Server Installations and Upgrades** 21
 - 3.1 Before You Begin 21
 - 3.1.1 Tools and Supplies Needed 21
 - 3.1.2 System References 21
 - 3.1.3 Cable Routing Reference 21
 - 3.2 General Installation Procedures 23
 - 3.2.1 Removing the Chassis Cover 23
 - 3.2.2 Installing the Chassis Cover 23
 - 3.2.3 Removing the Front Bezel 24
 - 3.2.4 Installing the Front Bezel 24
 - 3.2.5 Removing the Processor Air Duct 24
 - 3.2.6 Installing the Processor Air Duct 25
 - 3.3 Hot-Swappable Component Installation Procedures 25
 - 3.3.1 Installing or Replacing a Hard Drive 25
 - 3.3.1.1 Removing a Hard Drive Tray from the Chassis 26
 - 3.3.1.2 Attaching a Hard Drive to the Drive Tray 26
 - 3.3.2 Replacing a Power Supply Module 27
 - 3.3.2.1 Removing the Power Supply Module 28
 - 3.3.2.2 Installing the Power Supply Module 28
 - 3.3.2.3 Grounding a DC-Powered System 28
 - 3.4 Internal System Component Installation Procedures 28
 - 3.4.1 Configuring Jumpers on the Server Board 29
 - 3.4.1.1 Jumper Blocks 29
 - 3.4.1.2 CMOS Clear and Password Reset Procedures 30
 - 3.4.1.3 BMC Force Update Procedure 30



- 3.4.1.4 BIOS Select Jumper.....31
- 3.4.1.5 Serial B Port Configuration Jumper31
- 3.4.1.6 Processor Select Jumper.....31
- 3.4.2 Configuring Memory DIMMs.....32
 - 3.4.2.1 DIMM Population Rules.....33
 - 3.4.2.2 Supported DIMM Configurations33
 - 3.4.2.3 Sparing Mode Memory Configuration.....33
- 3.4.3 Installing and Removing Memory DIMMs34
 - 3.4.3.1 Installing DIMMs34
 - 3.4.3.2 Removing DIMMs35
- 3.4.4 Adding or Replacing a Processor35
 - 3.4.4.1 ESD and Handling Processors.....35
 - 3.4.4.2 Removing a Processor36
 - 3.4.4.3 Installing a New Processor.....37
 - 3.4.4.4 Setting the Processor Select Jumper39
 - 3.4.4.5 Installing the Heat Sink.....39
- 3.4.5 Installing or Replacing a PCI Add-in Card40
 - 3.4.5.1 Removing the PCI Riser Card Assembly40
 - 3.4.5.2 Removing a PCI card from the Riser Card Assembly41
 - 3.4.5.3 Installing a PCI Card in the Riser Card Assembly.....41
 - 3.4.5.4 Installing the Riser Card Assembly onto the Server Board43
- 3.4.6 Installing an Intel® Z-U130 Value Solid State Drive.....44
- 3.4.7 Installing Hardware RAID Components45
 - 3.4.7.1 Installing the Intel® RAID Smart Battery46
 - 3.4.7.2 Installing the Intel® RAID Activation Key and the ECC Mini-DIMM48
- 3.5 Internal System Component Replacement Procedures.....48
 - 3.5.1 Replacing an Optical Device48
 - 3.5.1.1 Removing the Optical Device Tray from the Chassis49
 - 3.5.1.2 Installing a New Optical Drive50
 - 3.5.2 Replacing a Fan Assembly.....51
 - 3.5.2.1 Replacing the CPU Four-Fan Assembly.....52
 - 3.5.2.2 Replacing the PCI Fan53
 - 3.5.3 Replacing the SAS Front Panel Board.....54
 - 3.5.3.1 Removing the SAS Front Panel (SFP) Board54
 - 3.5.3.2 Replacing the Light Pipe Assembly56
 - 3.5.3.3 Installing the SFP Board56
 - 3.5.4 Installing the Intel® Remote Management Module 257
 - 3.5.4.1 Installing the GCM Module.....57
 - 3.5.4.2 Installing the Intel® RMM257
 - 3.5.5 Replacing the Power Distribution Board.....59
 - 3.5.5.1 Removing the Power Distribution Board.....59
 - 3.5.5.2 Installing the Power Distribution Board Back into the Chassis59
 - 3.5.6 Replacing the Server Board.....60
 - 3.5.6.1 Removing the Server Board60
 - 3.5.6.2 Installing the Server Board Back into the Chassis61
 - 3.5.7 Replacing the CMOS Battery on the Server Board.....62
 - 3.5.8 Installing the Battery Insulator65
- 3.6 Installing the Server into a Rack66
 - 3.6.1 Connecting the Power Cord66
 - 3.6.2 Equipment Rack Precautions66
- 4 Server Utilities69**
 - 4.1 Using the BIOS Setup Utility.....69
 - 4.1.1 Starting Setup.....69
 - 4.1.2 If You Cannot Access Setup.....69
 - 4.1.3 Setup Menus.....69
 - 4.1.4 CMOS Clear and Password Reset Procedure70



- 4.1.5 BMC Force Update Procedure 71
- 4.2 Upgrading the BIOS..... 71
 - 4.2.1 Preparing for the Upgrade 71
 - 4.2.1.1 Recording the Current BIOS Settings 72
 - 4.2.1.2 Obtaining the Upgrade..... 72
 - 4.2.2 Updating the BIOS 72
- 4.3 Clearing the Password..... 72
- 4.4 Clearing the CMOS 73
- 5 Troubleshooting 75**
 - 5.1 Resetting the System..... 75
 - 5.2 Problems Following Initial System Installation 75
 - 5.2.1 First Steps Checklist 75
 - 5.3 Hardware Diagnostic Testing..... 76
 - 5.3.1 Verifying Proper Operation of Key System Lights 76
 - 5.3.2 Confirming Loading of the Operating System..... 77
 - 5.4 Specific Problems and Corrective Actions 77
 - 5.4.1 Power Light does not Light 77
 - 5.4.2 No Characters Appear on Screen 77
 - 5.4.3 Characters are Distorted or Incorrect 78
 - 5.4.4 System Cooling Fans do not Rotate Properly 78
 - 5.4.5 Cannot Connect to a Server 78
 - 5.4.6 Diagnostics Pass but the Connection Fails 79
 - 5.4.7 The Server Hangs When the Drivers are Loaded 79
 - 5.4.8 The Controller Stopped Working When an Add-in Adapter was Installed 79
 - 5.4.9 The Add-in Adapter Stopped Working Without Apparent Cause 79
 - 5.4.10 System Boots When Installing a PCI Card 79
 - 5.4.11 Problems with Newly Installed Application Software 80
 - 5.4.12 Problems with Application Software that Ran Correctly Earlier 80
 - 5.4.13 Devices are not Recognized under Device Manager (Windows* Operating System) 80
 - 5.4.14 Hard Drive(s) are not Recognized 80
 - 5.5 LED Information..... 81
 - 5.6 BIOS Error Messages 81
 - 5.6.1 BIOS POST Beep Codes..... 82
- 6 Warranty 85**
 - 6.1 Limited Warranty for Intel® Chassis Subassembly Products..... 85
 - 6.2 Extent of Limited Warranty 85
 - 6.3 Warranty Limitations and Exclusions 86
 - 6.3.1 Limitations of Liability 86
 - 6.4 How to Obtain Warranty Service..... 86
 - 6.4.1 Telephone Support 87
 - 6.4.2 Returning a Defective Product 87
- A Safety Information 89**
 - A.1 Emissions Disclaimer 89
 - A.2 Intended Uses 89
 - A.2.1 If AC Power Supplies Are Installed..... 89
 - A.2.2 If DC Power Supplies Are Installed..... 90
 - A.2.3 Temperature and Ventilation..... 91
 - A.3 Safety Cautions..... 91
- B Regulatory and Certification Information 101**
 - B.1 Product Regulatory Compliance 101
 - B.1.1 Product Safety Compliance 101
 - B.1.2 Product EMC Compliance - Class A Compliance 101



- B.1.3 Certifications / Registrations / Declarations 101
- B.2 Electromagnetic Compatibility Notices 102
 - B.2.1 FCC (USA) 102
 - B.2.2 Industry Canada (ICES-003) 103
 - B.2.3 Europe (CE Declaration of Conformity)..... 103
 - B.2.4 VCCI (Japan) 103
 - B.2.5 BSMI (Taiwan) 103
 - B.2.6 Regulated Specified Components 104
- C Getting Help 105
 - C.1 World Wide Web 105
 - C.2 Telephone..... 105

Figures

- 1 Intel® Carrier Grade Server TIGW1U 11
- 2 Carrier Grade Server TIGW1U Components 13
- 3 Rear View 14
- 4 Front View (Bezel Installed) 14
- 5 Front View (Bezel Removed) 15
- 6 Control Panel 15
- 7 Intel® Server Board S5000PHB Connector and Component Locations 17
- 8 Cooling Areas 19
- 9 Carrier Grade Server TIGW1U System Cable Routing 22
- 10 Removing the Chassis Cover 23
- 11 Removing the Front Bezel 24
- 12 Removing the Air Duct 25
- 13 Removing a Drive Tray from the Chassis 26
- 14 Removing a Disk Drive from the Drive Tray 26
- 15 Installing a Hard Drive 27
- 16 Inserting a New Drive Assembly into the Chassis 27
- 17 AC and DC Power Supplies 28
- 18 DIMM Slots and Channels 32
- 19 Installing Memory DIMMs 34
- 20 Cautions for Handling Processors 36
- 21 Removing the Heat Sink 36
- 22 Using the Socket Lever 37
- 23 Opening the Load Plate 37
- 24 Removing the Processor from its Shipping Cover 37
- 25 Installing the Processor in the Processor Socket 38
- 26 Removing the Socket Protective Cover 38
- 27 Closing the Processor Load Plate and Socket Lever 39
- 28 Removing the Riser Card Assembly 41
- 29 Removing a PCI-X Card from the Riser Card Assembly 41
- 30 Adding a PCI Express* Card into the Riser Card Assembly 42
- 31 Reinstalling the Riser Card Assembly 43
- 32 Installing the Intel® Z-U130 Value Solid State Drive 44
- 33 Connecting the Smart Battery Power Cable 46
- 34 Connecting the Smart Battery Cable Through the Battery Case 46
- 35 Installing the Smart Battery 47
- 36 Installing the Intel® RAID Activation Key and Mini-DIMM 48
- 37 Removing the Optical Device Tray from the Chassis 49
- 38 Using a Filler Panel in the Optical Drive Tray 49
- 39 Connecting the Optical Drive Interposer Board 50
- 40 Installing an Optical Drive in the Drive Tray 50



41	Installing the Drive Tray with Optical Drive Attached into the Server	51
42	PCI Fan and Four-Fan Set (with Bumpers Installed)	51
43	Installing the Fan Bumpers.....	52
44	Installing Fans into the Four-Fan Assembly Bracket	53
45	Installing the PCI Fan into the Bracket	54
46	Removing the SFP Board.....	55
47	Installing the SFP Board.....	56
48	Removing the GCM Port Filler Panel	57
49	Installing the Intel® Remote Management Module 2	58
50	Removing the PDB	59
51	Installing the PDB	60
52	Removing the Server Board.....	61
53	Installing the Server Board.....	62
54	Replacing the Battery	64
55	Folding the Battery Insulator	65
56	Attaching the Battery Insulator	66

Tables

1	Intel® Carrier Grade Server TIGW1U Features	11
2	Jumpers	29
3	Serial B Port Configuration Jumper	31
4	Maximum 6 DIMM System Memory Configuration - x8 Single Rank	33
5	Maximum 6 DIMM System Memory Configuration - x4 Dual Rank	33
6	FBDIMM Population Options.....	33
7	Keyboard Commands.....	70
8	LED Definitions	81
9	BIOS Error Messages.....	81
10	POST Error Beep Codes.....	83
11	Error Beep Codes Provided by an Intel® Remote Management Module 2	83



Revision History

Date	Revision	Description
April 2008	004	Edited processor information to include Quad-Core Intel® Xeon® processors 5400 series. Minor grammar and formatting changes. Added Intel® Z-U130 Value Solid State Drive Removed SysCon board Updated RAID component product names Updated Intel® Remote Management Module product name
April 2007	003	Added more recent information to Appendix A, "Safety Information" based on agency input.
April 2007	002	Added the "Configuring Jumpers on the Server Board" section. Added the "Recovery Jumpers" section. Added the "Serial Port B Configuration Jumper" section. Added the "Configuring Memory DIMMs" section. Added new Fan Replacement, SysCon board installation, and Hardware RAID 5 component installation sections to Chapter 3.
March 2007	001	Initial version



1 Introduction

1.1 About this Manual

Thank you for purchasing and using the Intel® Carrier Grade Server TIGW1U.

This manual is for system technicians who are trained and responsible for troubleshooting, upgrading, and repairing this server. This document provides a brief overview of the features of the board/chassis, a list of accessories or other components you may need, troubleshooting information, and instructions on how to add and replace components on the Carrier Grade Server TIGW1U.

Note: See the Support web site at <http://support.intel.com/support/telecom/computeboards/tigw1u/> for the latest version of this manual.

1.1.1 Manual Organization

Chapter 2 provides a brief overview of the Carrier Grade Server TIGW1U. In this chapter, you will find a list of the server board features, chassis features, illustrations of the product, and product diagrams to help you identify components and their locations.

Chapter 3 provides instructions on adding and replacing components. Use this chapter for step-by-step instructions and diagrams for installing or replacing components such as the memory, processor(s), front panel board, the battery, and other components.

Chapter 4 provides instructions on using the utilities that are shipped with the board or that may be required to update the system. This includes how to navigate through the BIOS (Basic Input/Output System) Setup screens, how to perform a BIOS update, and how to reset the password or CMOS (Complementary Metal Oxide Semiconductor). Information about the specific BIOS settings and screens is available in the *Intel® Server Board S5000PHB Technical Product Specification*.

Chapter 5 provides troubleshooting information. In this chapter, you will find BIOS error messages and POST (Power-on Self Test) code messages. You will also find suggestions for performing troubleshooting activities to identify the source of a problem.

1.2 What Your Server Includes

Your Intel® Carrier Grade Server TIGW1U includes the following components:

- One Intel® Server Board S5000PHB
- One 1U chassis
- Three SAS hard disk drive trays
- One optical drive
- A PCI-X* riser card assembly
- DC or AC power subsystem (one hot-swappable PSU; for redundancy a separately orderable supply is needed) and power distribution board (PDB)



- Four dual-rotor fans for cooling the processor(s), DIMM(s), PCI slot(s) and other internal components
- SAS front panel (SFP) board
- Cables and connectors

See the *Intel® Carrier Grade Server TIGW1U-F Hardware Reference Guide* for initial installation instructions.

1.3 Product Accessories

You may need or want to purchase one or more of the following accessory items for your server:

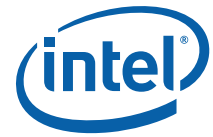
- One or two Dual-Core Intel® Xeon® processor 5100 Series or Quad-Core Intel® Xeon® processor 5400 Series
- Processor heat sink(s)
- 24 Gbyte DDR2-667 FBD ECC memory DIMM(s)
- SAS hard disk drives (HDDs)
- PCI-Express* (PCIe*) riser card; instead of the PCI-X riser card installed
- PCI-X or PCIe add-in card
- AC or DC power supply; second one for redundancy and hot-swapping
- Rack mount kit
- One Intel® Remote Management Module 2 (Intel® RMM2) and RMM NIC

For information about the accessories, memory, processors, and third-party hardware that have been tested and can be used with your system, and for ordering information for Intel products, see the accessories and spares list on <http://support.intel.com/support/telecom/computeboards/tigw1u/>

1.4 Additional Information and Software

If you need more technical information about this product or information about the accessories that can be used with this Carrier Grade Server TIGW1U, see the Technical Product Specifications (for both system and server board) and the test reports at <http://support.intel.com/support/telecom/computeboards/tigw1u/> for the following types of information:

- In-depth technical information about the server board included with this server, including BIOS settings and chipset information
- The latest product information
- Accessories or other Intel server products
- Hardware (peripheral boards, adapter cards) and operating systems that have been tested with this product
- DIMMs that have been tested with this product
- The power budget for this product
- Software to manage your server
- Diagnostics testing software
- Firmware and BIOS updates
- System drivers



2 Features

This chapter briefly describes the main features of the Intel® Carrier Grade Server TIGW1U. This chapter provides a diagram of the product, a list of the server features, and diagrams showing the location of important components and connections on the server system.

Figure 1 shows the Intel® Carrier Grade Server TIGW1U.

Figure 1. Intel® Carrier Grade Server TIGW1U

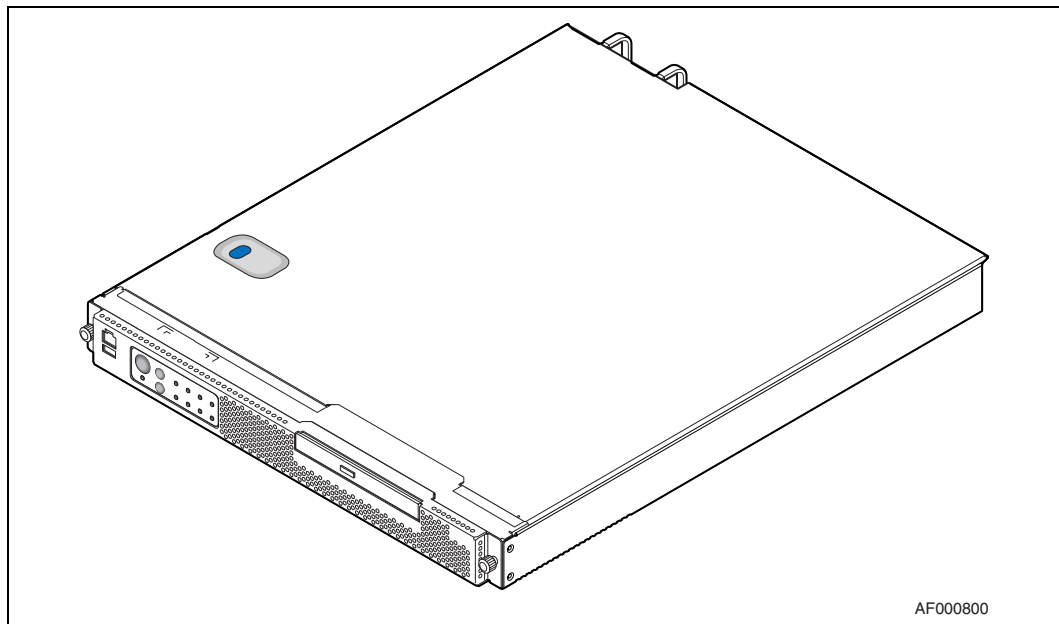


Table 1 summarizes the major features of the server system.

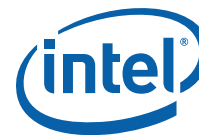
Table 1. Intel® Carrier Grade Server TIGW1U Features

Feature	Description
Compact, high-density system	Rack-mount server with a height of 1U (1.75 inches) and a depth of 20.0 inches
Configuration flexibility	Two-way capability in low profile and cost/value-effective packaging Stand-alone system Support for two processors: Dual-Core Intel® Xeon® processor 5100 Series or Quad-Core Intel® Xeon® processor 5400 Series Note: Quad-Core Intel® Xeon® processor 5400 series support is available only on Carrier Grade Server TIGW1U systems that have product codes TMRA0201W and TMRD0201W.
Serviceability	Rear access to hot-swappable power supplies Front access to hot-swappable disk drives



Table 1. Intel® Carrier Grade Server TIGW1U Features (Continued)

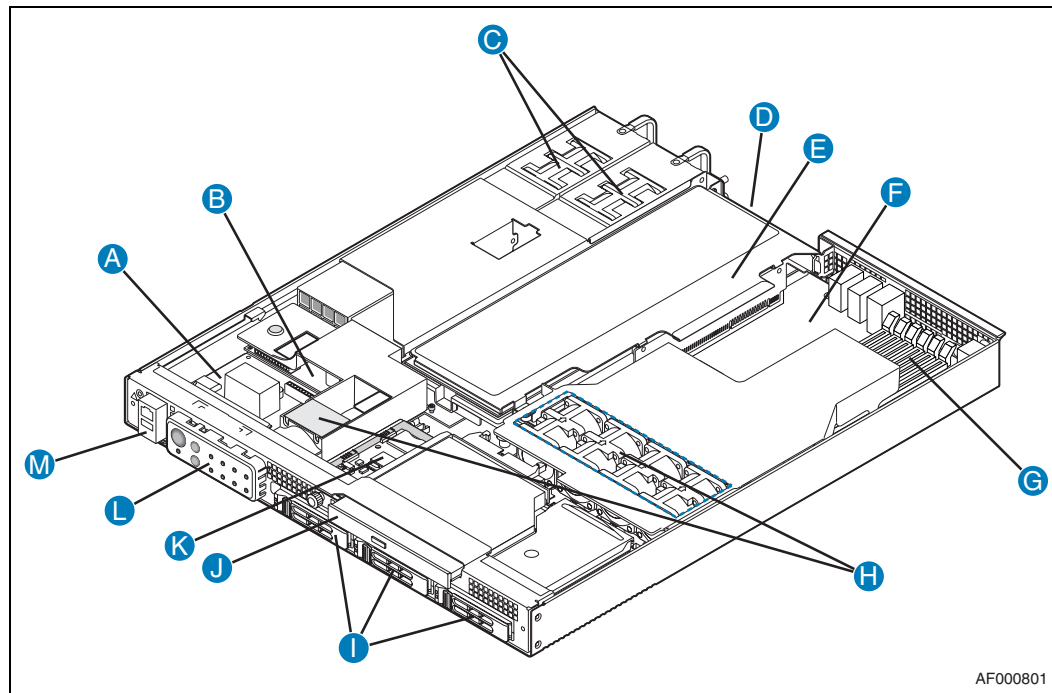
Feature	Description	
Availability	<p>Two hot-swappable 450 W power supplies in a redundant (1+1) configuration</p> <p>Integrated support for software RAID levels 0 and 1 using three internal hot-swappable 2.5-inch SAS disk drives and RAID levels 0, 1, and 10 when using additional external SAS drive(s) through rear-panel connector.</p> <p>Supports ROMB (RAID On Mother Board) hardware RAID operation for RAID 5 capability with addition of optional Intel® RAID Activation Key and ECC Mini-DIMM.</p> <p>Memory rank sparing</p>	
Manageability	<p>Remote management and diagnostics support</p> <p>Emergency management port (serial and LAN)</p> <p>IPMI 2.0-compliant</p> <p>Support for optional Intel® Z-U130 Value Solid State Drive</p>	
Upgradeability and investment protection	<p>Supports two processors from the Dual-Core Intel® Xeon® processor 5100 Series or from the Quad-Core Intel® Xeon® processor 5400 Series</p> <p>Note: Quad-Core Intel® Xeon® processor 5400 series support is available only on Carrier Grade Server TIGW1U systems that have product codes TMRA0201W and TMRD0201W. Multi-generational chassis</p> <p>Supports Intel® 64 architecture</p>	
System-level scalability	<p>Supports 24 Gbyte DDR2-533 or DDR2-667 MHz Registered SDRAM FBD DIMM memory</p> <p>Two sockets for Dual-Core Intel® Xeon® processor 5100 Series or Quad-Core Intel® Xeon® processor 5400 Series</p> <p>Note: Quad-Core Intel® Xeon® processor 5400 series support is available only on Carrier Grade Server TIGW1U systems that have product codes TMRA0201W and TMRD0201W. Full-height, full-length, 64-bit x 100/66 MHz PCI-X or x8 PCI Express slot</p> <p>Three internal hot-swappable 2.5-inch hard disk drives</p> <p>Supports up to four external SAS hard disk drives</p> <p>Low profile optical drive</p>	
Front panel	<p>Power switch</p> <p>Reset switch</p> <p>NMI switch</p> <p>ID switch</p> <p>Main power LED</p> <p>HDD activity LED</p>	<p>NIC activity LED</p> <p>ID LED</p> <p>Telco power alarm fault LED/relay</p> <p>Telco critical alarm fault LED/relay</p> <p>Telco major alarm fault LED/relay</p> <p>Telco minor alarm fault LED/relay</p>
I/O	<p>Front Access:</p> <ul style="list-style-type: none"> • Serial B port (RJ45) • USB port 	<p>Rear Access:</p> <ul style="list-style-type: none"> • Dual PS/2 ports for keyboard and mouse • Serial B port (RJ45) • Two USB ports • Four GbE ports • 100 Mb RMM management port • SAS 4x drive port with RAID support • Video port • Telco alarms port



2.1 Server Components

Figure 2 shows the internal components of the Carrier Grade Server TIGW1U (top cover and front bezel removed).

Figure 2. Carrier Grade Server TIGW1U Components

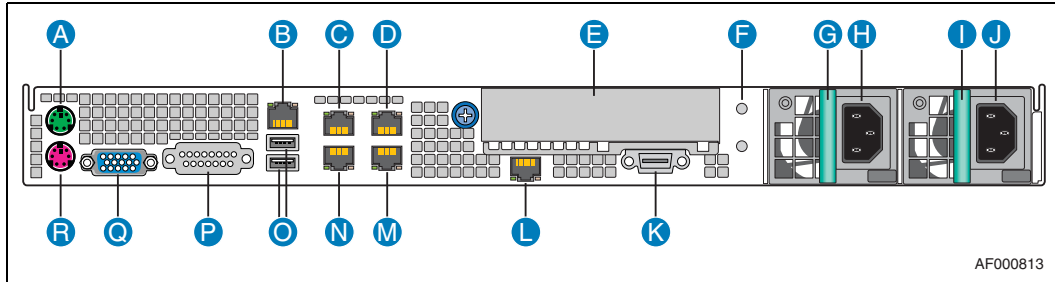


Item	Description	Item	Description
A	SAS front panel (SFP) board	H	System fans
B	Power distribution board (PDB)	I	SAS hard disk drive bays
C	Power supplies (AC or DC)	J	Optical drive
D	PCI card bracket (full-length)	K	Intel® Z-U130 Value Solid State Drive (optional)
E	Riser card assembly	L	Front panel LEDs and switches
F	Server board	M	Front panel serial port (COM2 / Serial B), USB connector
G	System memory		

2.2 Back Panel

Note: Figure 3 shows the AC input power configuration. Items G to J can also be configured for DC operation.

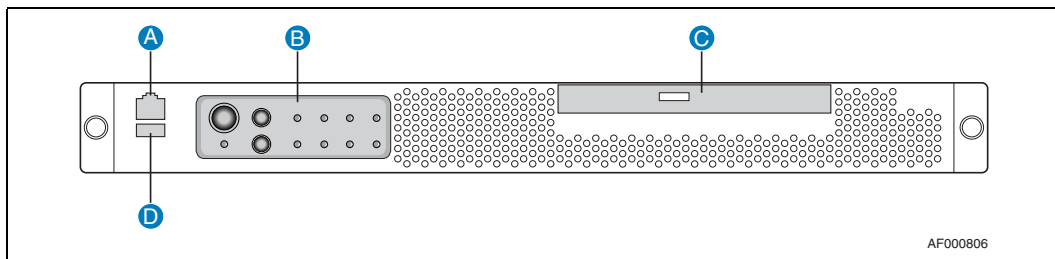
Figure 3. Rear View



Item	Description	Item	Description
A	PS/2 mouse	J	AC power socket
B	RJ45 serial port (COM2/Serial B)	K	External x4 SAS connector
C	RJ45 NIC connector	L	Intel® Remote Management Module 2 (Intel® RMM2) connector (optional)
D	RJ45 NIC connector	M	RJ45 NIC connector
E	PCI add-in card bracket or filler panel	N	RJ45 NIC connector
F	Ground studs for DC input (2)	O	USB port 0 and USB port 1
G	Power supply #2	P	Telco alarms connector
H	AC power connection	Q	Video connector
I	Power supply #1	R	Keyboard connector

2.3 Front Panel

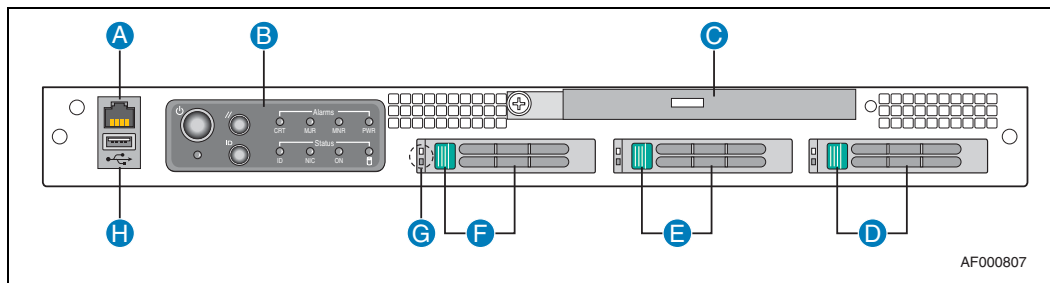
Figure 4. Front View (Bezel Installed)



Item	Description	Item	Description
A	RJ45 serial port (COM2/Serial B)	C	Optical drive
B	Control panels	D	USB port 2

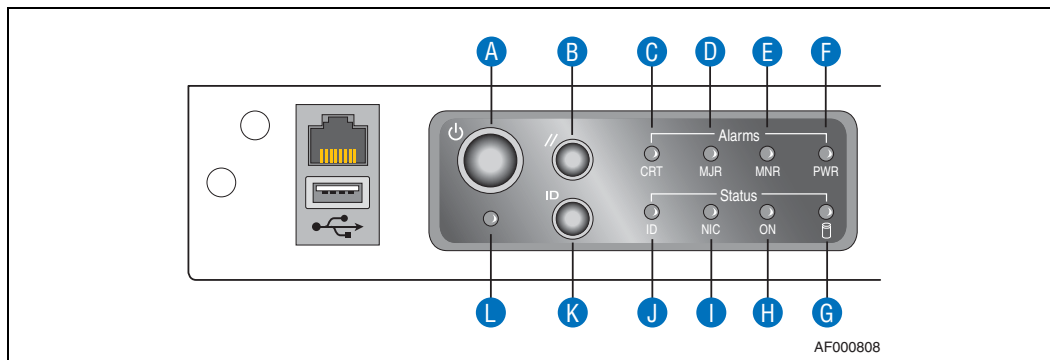


Figure 5. Front View (Bezel Removed)



Item	Description	Item	Description
A	RJ45 serial port (COM2/Serial B)	E	Drive bay 1 and handle
B	Front panel control switches and LEDs	F	Drive bay 2 and handle
C	Optical drive	G	HDD LEDs top = fault (amber) bottom = activity (ready/green; active/blinking green)
D	Drive bay 0 and handle	H	USB port 2

Figure 6. Control Panel



Item	Feature	Description
Front Panel Switches		
A	Power switch	Toggles the system power
B	Reset switch	Resets the system
K	ID switch	Toggles the system ID LED
L	NMI switch	Asserts NMI to the server board
Front Panel Alarm LEDs and Relays		
C	Critical (amber)	When continuously lit, this indicates a Critical System Fault. A critical system fault is an error or event with a fatal impact to the system. In this case, the system cannot continue to operate. An example is the loss of a large section of memory, or other corruption, that renders the system non-operational. The front panel critical alarm relay engages.



Item	Feature	Description
D	Major (amber)	When continuously lit, it indicates a Major System Fault. A major system fault is an error or event that has discernable impact to system operation. In this case, the system can continue to operate but in a “degraded” fashion (reduced performance or loss of non-fatal feature reduction). An example is the loss of one of two mirrored disks. The front panel major alarm relay engages.
E	Minor (amber)	When continuously lit, it indicates a Minor System Fault. A minor system fault is an error or event that is detected by the system but likely has little impact to system operation. An example is a correctable ECC error. The front panel minor alarm relay engages.
F	Power (amber)	When continuously lit, it indicates a Power System Fault. The front panel power alarm relay engages.
Front Panel Status LEDs		
G	Disk activity/fault LED (green/amber)	Indicates SAS hard drive activity when blinking green, or a disk SAS hard drive fault when amber. See the SAS HDD LEDs to determine specific drive activity or fault.
H	Main power LED (green)	When continuously lit, it indicates the presence of DC power in the server. The LED goes out when the power is turned off or the power source is disrupted.
I	NIC activity LED (green)	Indicates NIC activity
J	System ID LED (white)	Indicates system identity. This LED can be toggled remotely or by front-panel ID switch for identification purposes

2.4 Rear Panel Ethernet Ports

The server has four GbE NIC ports mounted on the server board. These ports are accessible from the rear of the chassis. Copper and fiber options are available. An additional set of four rear-accessible GbE NIC ports can be added by using an x4 GbE NIC PCI Express* (PCIe*) or PCI-X* card with rear I/O panel access ports. There are no GbE NIC ports accessible from the front of the Carrier Grade Server TIGW1U.

The GbE NIC ports are intended to be installed with shielded cabling that is grounded at both ends of the cable.

Warning: The intra-building port(s) of the equipment or subassembly is suitable for connection to intra-building or unexposed wiring or cabling only. The intra-building port(s) of the equipment or subassembly **MUST NOT** be metallically connected to interfaces that connect to the OSP or its wiring. These interfaces are designed for use as intra-building interfaces only (Type 2 or Type 4 ports as described in GR-1089-CORE, Issue 4) and require isolation from the exposed OSP cabling. The addition of Primary Protectors is not sufficient protection in order to connect these interfaces metallically to OSP wiring.

2.5 SAS Front Panel (SFP) Board

The SAS front panel (SFP) board is located in front of the power supplies and extends behind the hard drives. The SAS drives connect into the SFP board for power and signals. The SFP board also provides optical drive and fan power connectors and the user interface for the system's front panel.

2.5.1 Front Panel Board Features

The SFP board has the following features:

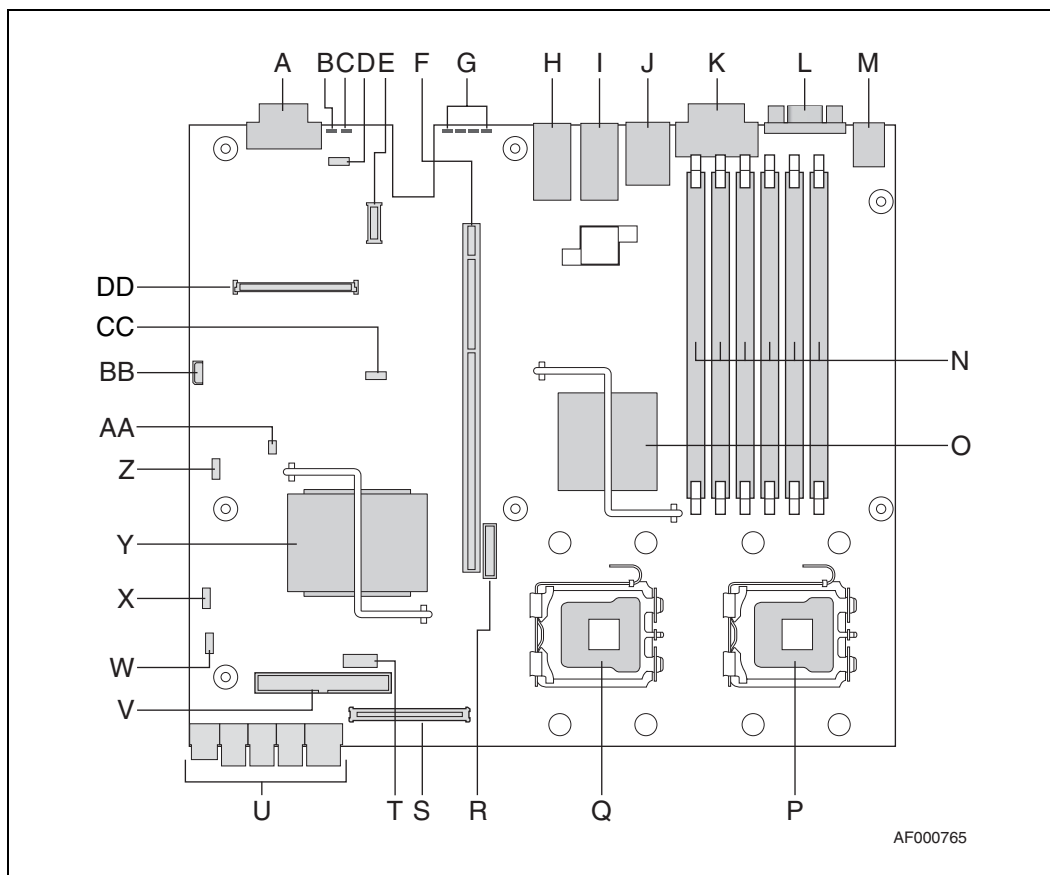
- Four switches to control power-on, reset, NMI, and the system ID LED
- Four alarm relay and power relay LEDs



- One system ID LED that can be controlled remotely or by the system ID switch
- Two system activity LEDs that indicate power-on and NIC activity
- One hard drive activity LED that indicates fault status for drives 0 and 1
- Three hot-swappable SAS hard drives
- Connectors on the SFP board for interfacing to the server board and fans

2.6 Server Board Connector and Component Locations

Figure 7. Intel® Server Board S5000PHB Connector and Component Locations



Item	Description	Item	Description
A	SAS connector	P	CPU #2 socket
B	System identification LED (blue)	Q	CPU #1 socket
C	System status LED (green/amber)	R	CMOS battery
D	Serial Port B DSR/DCD jumper (J2A2)	S	Flex connector to front panel board
E	RMM NIC connector	T	Serial Port A header
F	PCI Express/PCI-X riser card super slot	U	Main power connector
G	POST code diagnostic LEDs	V	PATA (IDE) connector
H	Dual-port LAN connector	W	Password clear jumper (J1H2)



Item	Description	Item	Description
I	Dual-port LAN connector	X	BIOS Bank Select jumper (J1G1)
J	Dual USB 2.0/RJ45 serial port B connector	Y	Intel® ESB2-E I/O controller hub
K	Telco alarms connector	Z	CMOS Clear jumper (J1F1)
L	Video connector	AA	BMC Force Update jumper (J1E3)
M	PS/2 keyboard and mouse connector	BB	3-Pin IPMB header
N	FBDIMM slots	CC	Processor select jumper
O	Intel® 500P Memory Controller Hub (MCH)	DD	Intel® Remote Management Module 2 (Intel® RMM2) connector

2.7 Hard Disk Drives

The Carrier Grade Server TIGW1U chassis provides three hot-swappable hard drive tray assemblies at the front of the chassis.

For information on how to install these drives, see Section 3.3.1, “Installing or Replacing a Hard Drive”.

Note: The Carrier Grade Server TIGW1U does not support all SAS hard drives. For a list of validated hard drive manufacturers and hard drive types, see the *Tested Hardware and Operating Systems List* (THOL) at <http://support.intel.com/support/telecom/computeboards/tigw1u/>

Each drive can consume up to 17 W of power. Drives must be specified to run at a maximum ambient temperature of 45° C.

2.8 Riser Card Assembly

The Carrier Grade Server TIGW1U default riser card assembly contains a PCI-X riser card. There is also a PCI Express (PCIe) version available as a separately orderable accessory.

The Intel® Server Board S5000PHB implements a PCI super slot that contains the signals necessary for a PCI/PCI-X or PCIe expansion slot. One of two different low-profile riser cards is inserted into the super slot to access the appropriate signals and provide the appropriate connector for a PCI/PCI-X or PCIe riser card. (See Figure 7 for this location.) The Carrier Grade Server TIGW1U is designed to accommodate full-length, full-height PCI add-in cards with the card's I/O bracket accessible through an opening in the rear panel of the system.

The PCI/PCI-X riser card supports speeds of 33 or 66 MHz PCI and 100 or 133 MHz PCI-X.

The PCIe riser card implements a x8 link interface, and can be used with add-in cards that implement x1, x4, or x8 interfaces.

See Section 3.4.5, “Installing or Replacing a PCI Add-in Card” for how to install a PCI add-in card or how to replace the default PCI-X riser card assembly with a PCIe version.

2.8.1 PCI/PCI-X Riser Card

The PCI/PCI-X riser card, which is the default riser card installed in the assembly, supports one 3.3 V 64-bit slot and speeds of 33 or 66 MHz for PCI and 66, 100, or 133 MHz for PCI-X. The bus speed varies from 66 MHz to 100 MHz depending on the



type of PCI add-in card configured in the PCI-X riser card. For detailed information about the pinouts and electrical specifications, see the *Intel® Carrier Grade Server TIGW1U Technical Product Specification*.

2.8.2 PCI Express Riser Card

The PCI Express (PCIe) riser card implements a x8 link interface and can be used with add-in cards with a x1, x4, or x8 interface. For detailed information about the pinouts and electrical specifications, see the *Intel® Carrier Grade Server TIGW1U Technical Product Specification*.

2.9 Power Supply

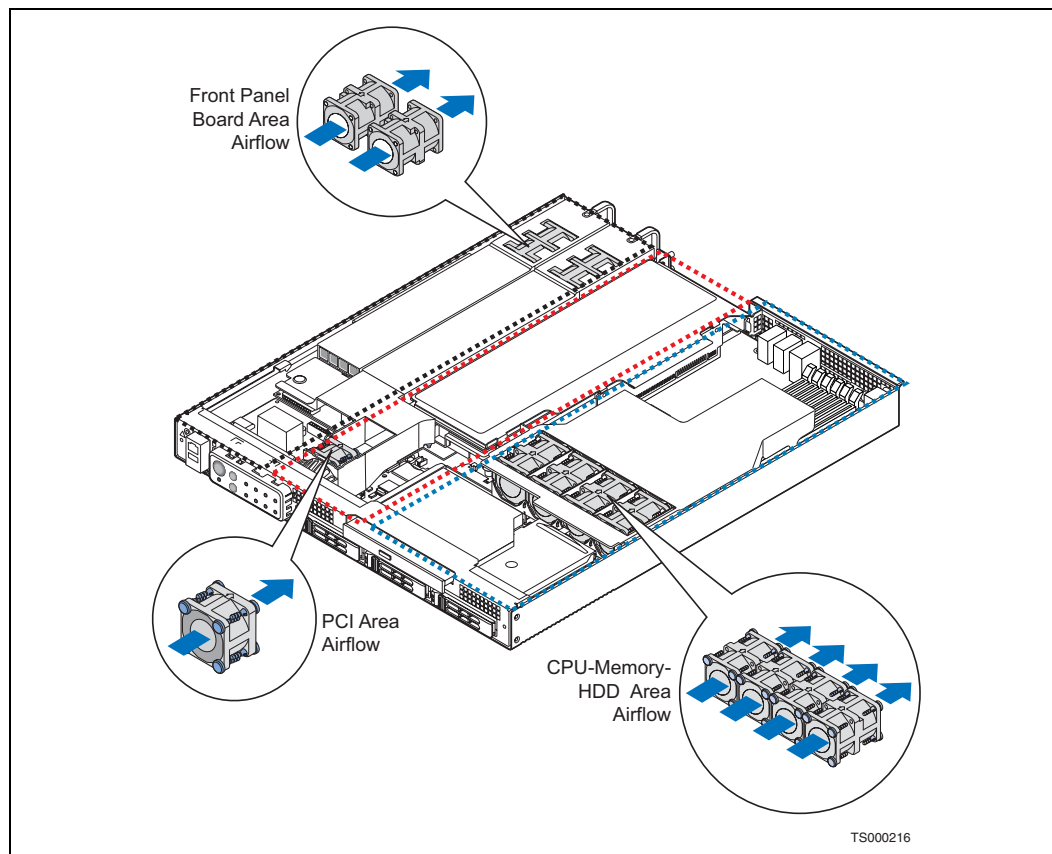
The power subsystem has up to two power supply modules capable of operating in redundant mode and a power distribution board (PDB). A power supply filler panel for the empty power supply site is supplied for systems without redundancy.

The power supply is rated for 450 W output capability in full AC (or DC) input voltage range.

2.10 System Cooling

There are three cooling areas in the Carrier Grade Server TIGW1U: front panel board area, PCI area, and CPU-memory-HDD area.

Figure 8. Cooling Areas





2.10.1 Front Panel Cooling Area

The left one-fourth of the SFP board and the portion of the power distribution board (PDB) in this area are cooled by 40 x 40 x 56 mm PSU dual-rotor fans. One PSU fan is sufficient to cool this portion of the front panel board area and two PSU fans provide cooling redundancy for this area.

PSU fans draw air in through the front bezel and from vents in the left front side of the chassis. The air is exhausted out the rear of the PSUs. The left wall of the PCI fan air duct and the PSU guide wall provide an air flow barrier between the front panel board cooling area and the PCI cooling area.

2.10.2 PCI Cooling Area

The 40 x 40 x 28 mm single-rotor PCI fan cools the portions of the server board, PDB, and SFP that are in this area as well as a PCI add-in card installed in the riser card assembly.

The PCI fan draws in air through the front bezel and exhausts through the rear of the system. A plastic air duct directs the air flow in this area, houses the PCI fan, and provides air flow barriers between:

- The front panel board and the PCI cooling areas
- The PCI and the CPU / memory / HDD cooling areas

A second plastic part behind the PCI air duct continues the air flow barrier between the PCI cooling area and the CPU / memory / HDD cooling area. The riser card provides the third portion of the air flow barrier between the PCI cooling area and the CPU / memory / HDD cooling area.

2.10.3 CPU / Memory / HDD Cooling Area

The server uses four 40 x 40 x 56 mm dual-rotor fans that are assembled in a sheet metal bracket attached to the chassis.

The server draws air in through the front bezel and exhausts it out the rear of the chassis. The CPU / memory / HDD cooling area air flow path is isolated from the rest of the system by an air duct and riser card. Air entering the CPU / memory air duct is preheated by the hard drives.

2.11 Hardware Requirements

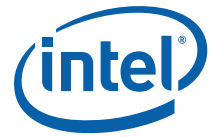
To avoid integration difficulties and possible board damage, your system must meet the requirements outlined in the subsections below. For a list of qualified components, see Section 1.4, "Additional Information and Software".

2.11.1 Processor

The server board accommodates two Dual-Core Intel® Xeon® processor 5100 Series or two Quad-Core Intel® Xeon® processor 5400 series.

2.11.2 Memory

The S5000PHB server board supports up to six DDR2-533 or DDR2-667 Fully Buffered DIMMs (FBD memory) in six DIMM slots across two channels, Channel 0 and Channel 1. Channel 0 consists of DIMM sockets A1, A2, and A3. Channel 1 consists of DIMM sockets B1, B2, and B3. See Section 3.4.2, "Configuring Memory DIMMs" on page 32 for population rules and configuration information.



3 Server Installations and Upgrades

3.1 Before You Begin

Before working with your server product, pay close attention to the safety instructions provided in this manual. See Appendix A, "Safety Information".

Warning: Electrostatic discharge (ESD) and ESD protection: ESD can damage disk drives, boards, and other parts. We recommend that you perform all procedures in this chapter only at an ESD workstation. If an ESD workstation is not available, provide some ESD protection by wearing an antistatic wrist strap attached to chassis ground (any unpainted metal surface) on your server when handling parts.

3.1.1 Tools and Supplies Needed

- Phillips* (cross-point) screwdriver (#1 bit and #2 bit)
- Anti-static wrist strap and conductive foam pad

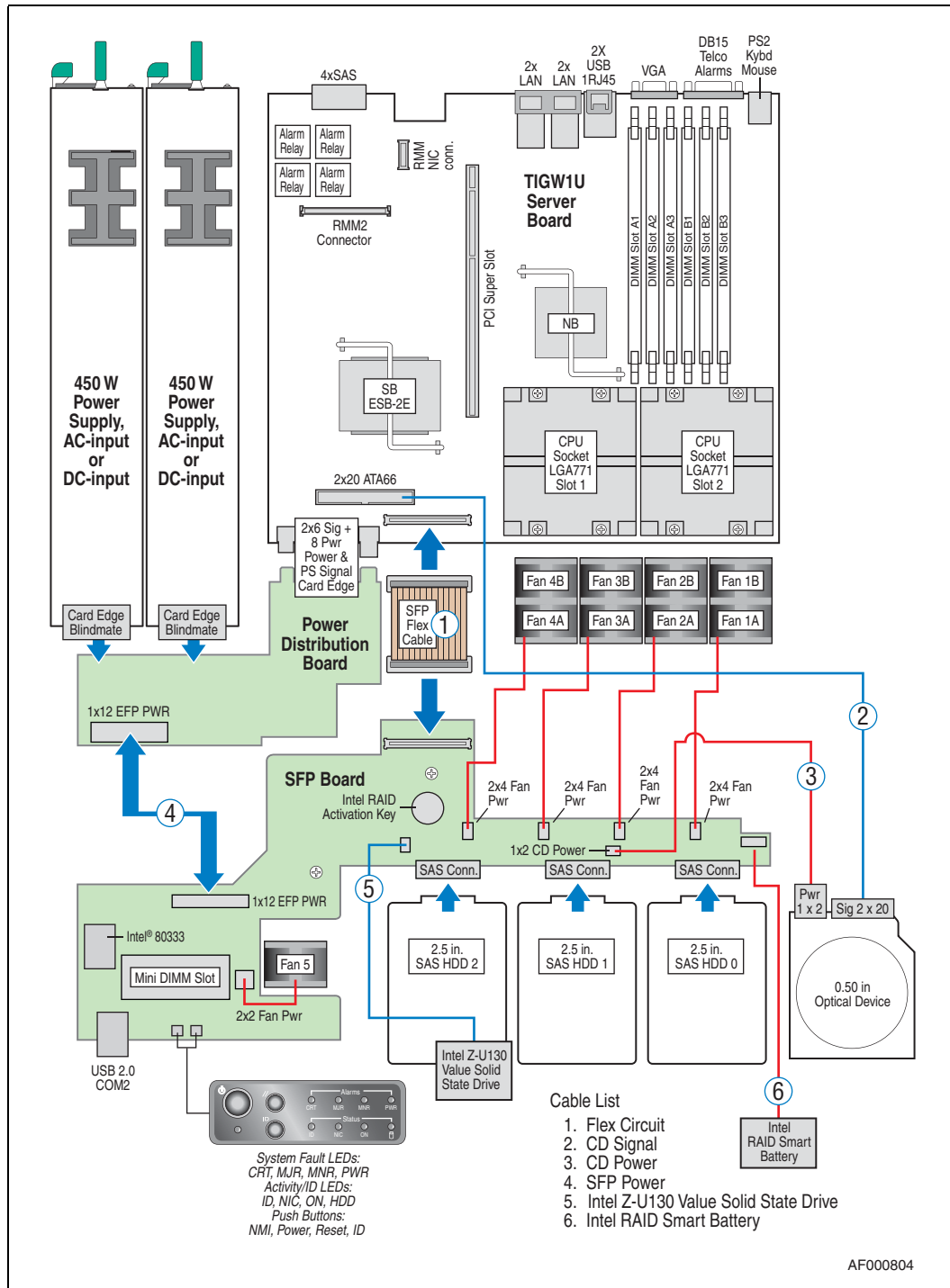
3.1.2 System References

All references to left, right, front, top, and bottom assume that you are facing the front of the server, as it would be positioned for normal operation.

3.1.3 Cable Routing Reference

It is important for cables to be connected correctly. See Figure 9. For more detailed information about cable connectors, see the *Intel® Carrier Grade Server TIGW1U Technical Product Specification*.

Figure 9. Carrier Grade Server TIGW1U System Cable Routing





3.2 General Installation Procedures

The following sections present general installation and removal procedures that are required before removing or installing non-hot-swappable internal components.

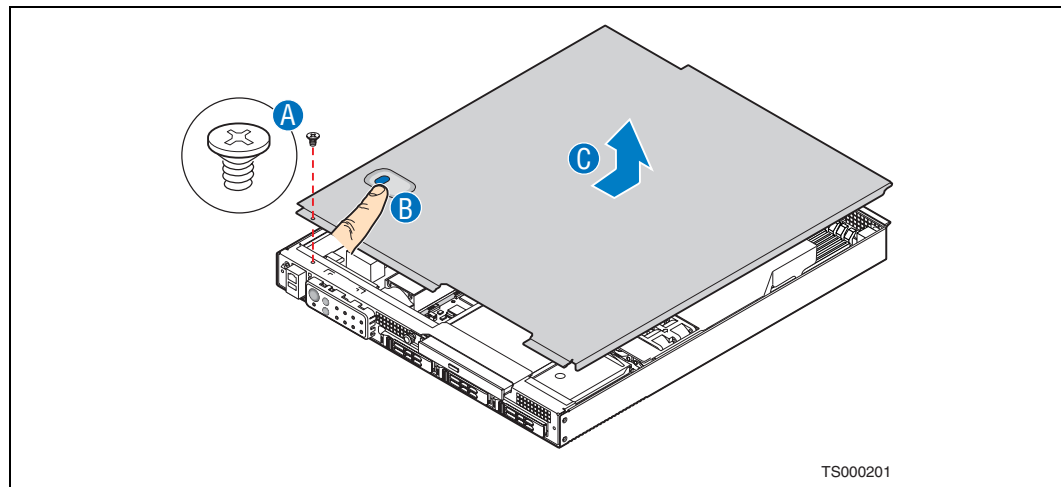
3.2.1 Removing the Chassis Cover

The Carrier Grade Server TIGW1U must be operated with the top cover in place to ensure proper cooling. You need to remove the top cover to add or replace components inside of the server. Before removing the top cover, power down the server system and unplug all peripheral devices and the power cable.

Note: A non-skid surface or a stop behind the server may be needed to prevent the server from sliding on your work surface.

1. Observe the safety and ESD precautions in Appendix A, "Safety Information".
2. Turn off all peripheral devices connected to the server. Turn off the server.
3. Disconnect the power cord.
4. Remove the shipping screw from the front of the chassis on the left side ("A"), if present.
5. While pressing down the blue button at the top of the chassis ("B"), slide the top cover back until it stops. ("C").
6. Lift the cover straight up to remove it. ("C")

Figure 10. Removing the Chassis Cover



3.2.2 Installing the Chassis Cover

1. Place the cover over the chassis so that the side edges of the cover sit just inside the chassis sidewalls, with the front of the cover with about a 1/8-inch (3-mm) gap between the chassis cover and the sheet-metal at the front of the chassis.
2. Press down slightly on the chassis cover behind the peripheral area and slide the cover forward until it clicks into place.
3. (Optional) Install the shipping screw.
4. Reconnect all peripheral devices and the power cord.

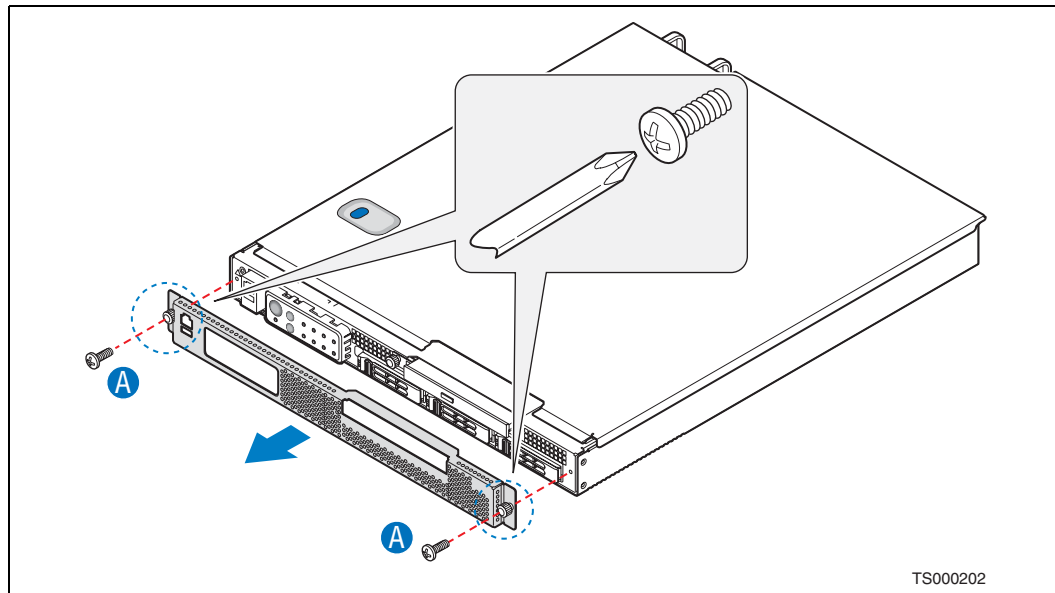
Caution: This unit must be operated with the top cover installed to ensure proper cooling.

3.2.3 Removing the Front Bezel

Note: Hold the bezel in place while you loosen the screws. After both screws are loosened, the bezel drops from the chassis.

1. Remove the left-side screw. (“A” in Figure 11)
2. Remove the right-side screw to release the bezel.

Figure 11. Removing the Front Bezel



3.2.4 Installing the Front Bezel

While holding the front bezel in place, tighten the captive screws at the left and right edges of the bezel.

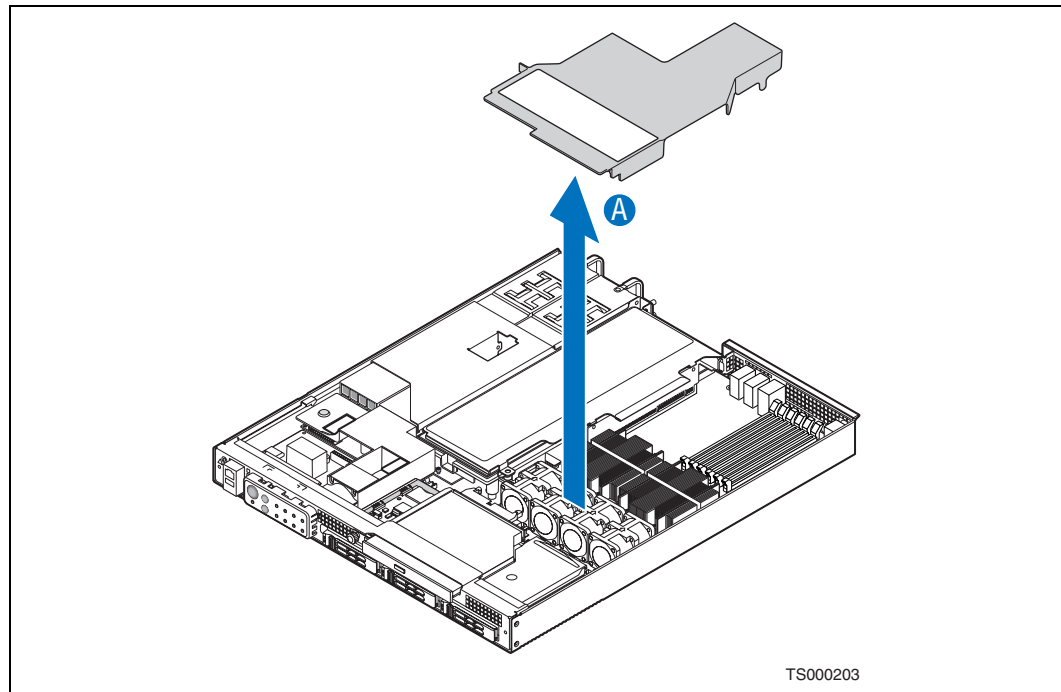
3.2.5 Removing the Processor Air Duct

The air duct must be removed to access the processors, memory DIMMs, and the four-fan assembly. The processor air duct is required for proper airflow within the chassis. Be sure the air duct is in place before installing the chassis cover. To remove the processor air duct:

1. Power down the server system and unplug all peripheral devices and the AC power cable.
2. Remove the chassis cover. For instructions, see Section 3.2.1, “Removing the Chassis Cover” on page 23.
3. Lift the air duct straight up and lift it from the chassis (“A” in Figure 12).



Figure 12. Removing the Air Duct



3.2.6 Installing the Processor Air Duct

1. Place the processor air duct over the processor sockets and four-fan assembly, using caution to make sure you do not pinch any wires beneath the edges of the air duct.
The top of the installed air duct should be flush with the top surface of the PCI riser card assembly.
2. Replace the chassis cover if you have completed all work inside of the chassis.

3.3 Hot-Swappable Component Installation Procedures

The following components are hot-swappable and do not require powering down the system or removing the chassis cover:

- Hard disk drives
- AC and DC power supplies

3.3.1 Installing or Replacing a Hard Drive

Up to three hot-swappable drives can be installed in your Carrier Grade Server TIGW1U. You must remove the front bezel to add or replace a hard drive.

Caution: If you install fewer than three hard drives, the empty bays must be populated with drive trays that have baffles in them to maintain proper system cooling.

The Carrier Grade Server TIGW1U does not support all SAS hard drives. To see a list of validated manufacturers and hard drive types, go to:
<http://support.intel.com/support/telecom/computeboards/tigw1u/>

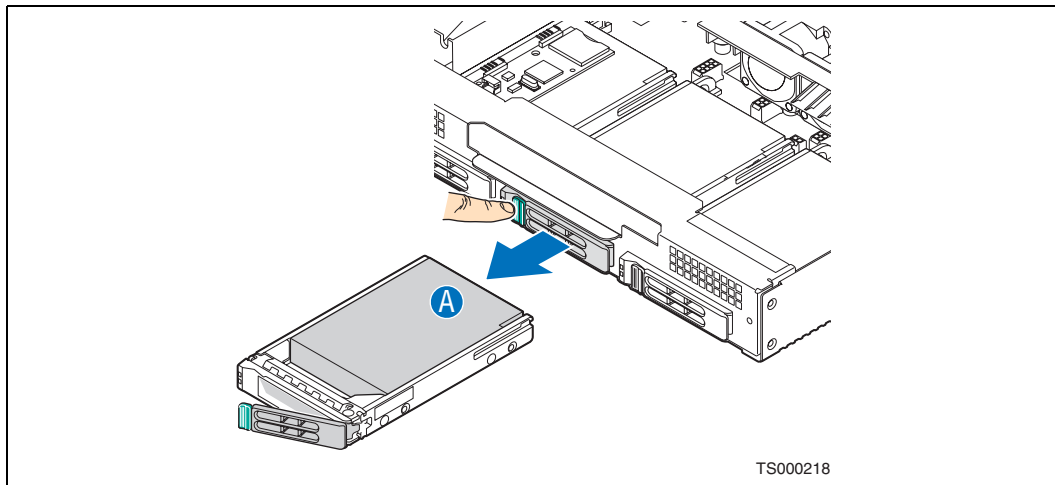
3.3.1.1 Removing a Hard Drive Tray from the Chassis

1. Remove the front bezel. For instructions, see Section 3.2.3, “Removing the Front Bezel” on page 24.
2. Select the drive bay where you want to install the drive. Remove the drive tray by pressing the green button to open the lever.

Note: If you will have fewer than three drives installed, drive bay 0 must be used first, then drive bay 1.

3. Pull the drive tray assembly out of the chassis. (“A” in Figure 13)

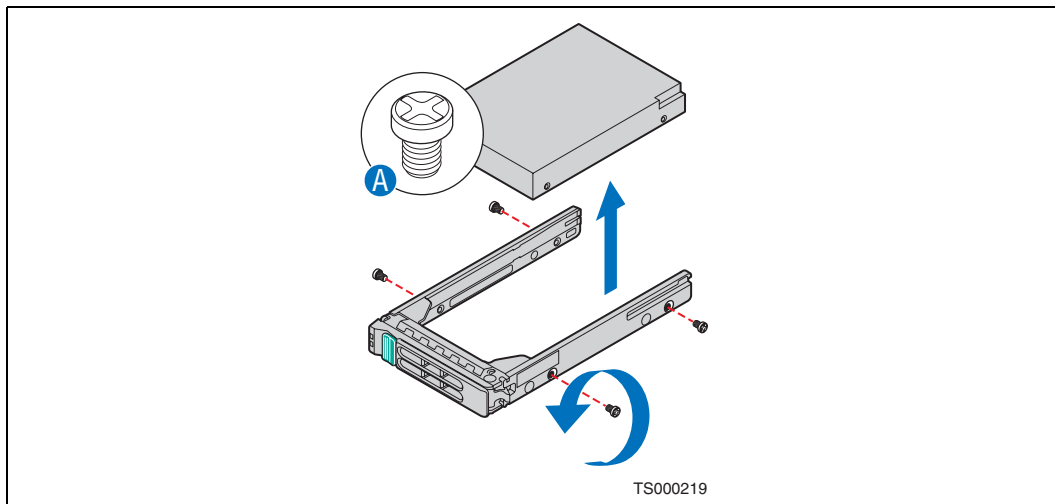
Figure 13. Removing a Drive Tray from the Chassis

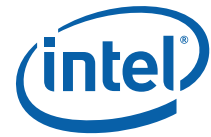


3.3.1.2 Attaching a Hard Drive to the Drive Tray

1. If a drive is already installed (that is, if you are replacing the drive), remove it by unfastening the four screws that attach it to the drive tray. (“A” in Figure 14)

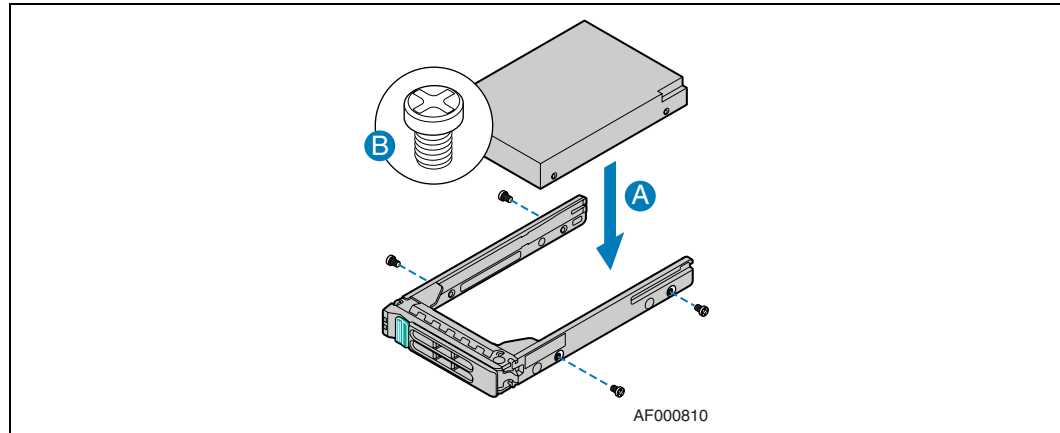
Figure 14. Removing a Disk Drive from the Drive Tray





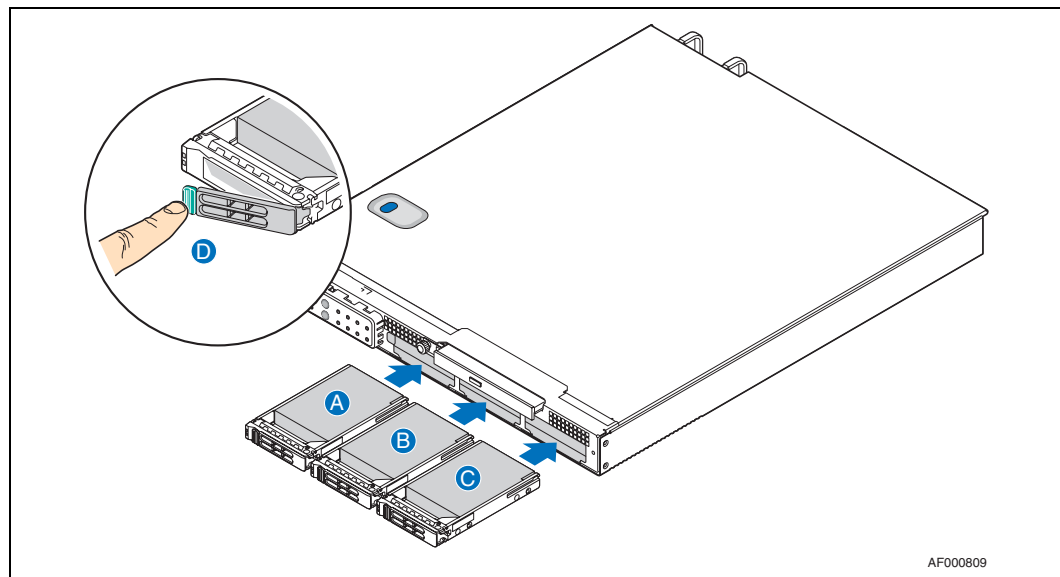
2. Install the new drive in the drive tray and secure the drive with the four screws that come with the drive tray. ("A" and "B" in Figure 15)

Figure 15. Installing a Hard Drive



3. With the drive tray locking lever fully open, push the hard drive tray into the drive bay in the chassis until it stops. ("A", "B" and "C" in Figure 16)
4. Press the lever until it snaps shut to close the drive in the bay. ("D")

Figure 16. Inserting a New Drive Assembly into the Chassis



5. Replace the front bezel.

3.3.2 Replacing a Power Supply Module

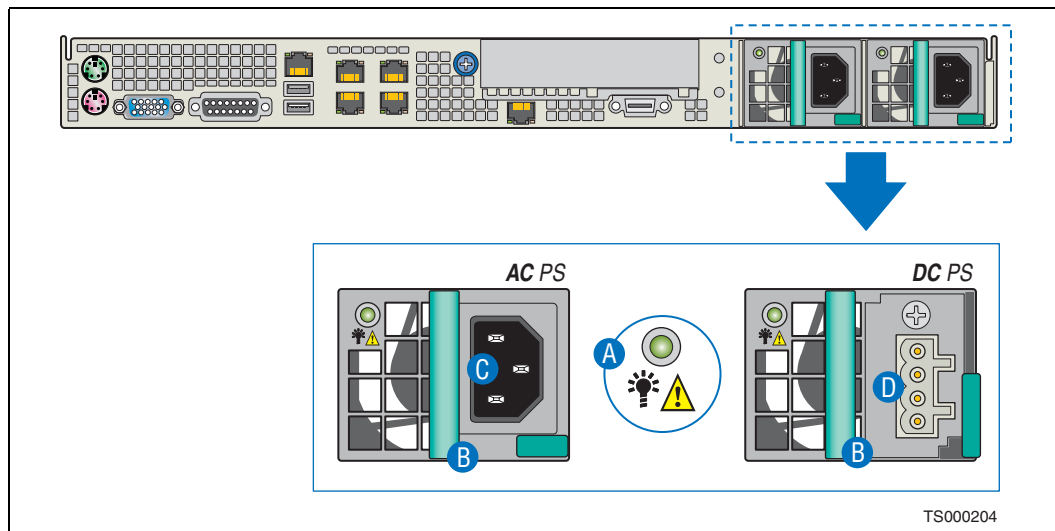
Caution: Your server does not have a redundant power supply unless you have purchased the optional second power supply module. If there is no second supply, before replacing the power supply you must first take the server out of service, turn off all peripheral devices connected to the system, turn off the system by pressing the power button, and unplug the power cord from the system or wall outlet.

To maintain hot-swap capability, make sure an active power supply module is in each chassis slot before replacing (hot-swapping) a power supply module.

3.3.2.1 Removing the Power Supply Module

1. Check the status LED to determine which power supply has failed (“A” in Figure 17). Disconnect the appropriate power cable.
2. Press and hold the green safety lock to the left to disengage the power supply module.
3. Grasp the handle and pull the power supply from the chassis. (“B”)

Figure 17. AC and DC Power Supplies



3.3.2.2 Installing the Power Supply Module

Press and hold the green safety lock to the left and slide the power supply module into the chassis slot.

3.3.2.3 Grounding a DC-Powered System

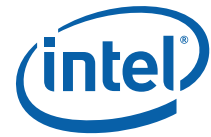
The DC chassis provides two #10-32 threaded studs for chassis enclosure grounding. A single 90° standard barrel, two-hole, compression terminal lug with 5/8-inch pitch suitable for #14-10 AWG conductor (such as the Thomas & Betts* terminal lug p/n 256-31426-141) must be used for proper safety grounding. See “D” in Figure 3, “Rear View” on page 14 for the location of the ground studs.

A crimping tool may be needed to secure the terminal lug to the grounding cable.

3.4 Internal System Component Installation Procedures

Note:

The procedures in this section assume that you have powered down the server and removed the chassis cover as described in Section 3.2, “General Installation Procedures” on page 23.



3.4.1 Configuring Jumpers on the Server Board

The jumpers are located on the S5000PHB server board, which is in the rear left side of the Carrier Grade Server TIGW1U chassis. To configure the jumpers on the server board, in addition to removing the chassis cover, you also must remove the processor air duct (see Section 3.2.5, “Removing the Processor Air Duct” on page 24) and the PCI riser card assembly (see Section 3.4.5.1, “Removing the PCI Riser Card Assembly” on page 40). All other components installed on the server board can remain in place.

The jumpers that can be configured are:

- J2A2 (Serial Port B DSR/DCD jumper)
- J1H2 (Password Clear jumper)
- J1G1 (BIOS Bank Select jumper)
- J1F1 (CMOS Clear jumper)
- J1E3 (BMC Force Update jumper)
- J3E2 (Processor select jumper)

See Figure 7 for the location of these jumpers. The following sections give more detailed information about the settings.

3.4.1.1 Jumper Blocks

The server board has several 2-pin and 3-pin jumper blocks (see Figure 7) that can be used to configure, protect, or recover specific features of the server board. Pin 1 on each jumper block is denoted by an “*” or “▼”. Table 2 describes the function of each recovery jumper on the server board.

Table 2. Jumpers

Jumper Name	Pins	What happens at system reset...
J1E3: BMC Force Update	No Jumper	BMC Firmware Force Update Mode – Disabled (Default)
	Jumper	BMC Firmware Force Update Mode – Enabled
J1H2: Password Clear	1-2	These pins should have a jumper in place for normal system operation. (Default)
	2-3	If these pins are jumpered, administrator and user passwords will be cleared on the next reset. These pins should not be jumpered for normal operation.
J1G1: Bank Select	1-2	Force to lower flash bank during boot-up
	2-3	Normal operation/use primary flash bank (Default)
J1F1: CMOS Clear	1-2	These pins should have a jumper in place for normal system operation. (Default)
	2-3	If these pins are jumpered, the CMOS settings will be cleared on the next reset. These pins should not be jumpered for normal operation
J3E2: Processor	1-2	If these pins are jumpered, the system is configured for a Dual-Core Intel® Xeon® processors 5100 series. (Default) Caution: Pins 2-3 should never be jumpered. The system will not function correctly if these pins are jumpered.
	No Jumper	If no pins are jumpered, the system is configured for a Quad-Core Intel® Xeon® processors 5400 series.
Note: Bold entry in “Pins” column indicates default configuration.		



3.4.1.2 CMOS Clear and Password Reset Procedures

The procedure is identical for clearing the CMOS and the password, but has changed from previous generation server boards from Intel. The following steps outline the new procedure for both operations.

1. Power down the server and remove the power cable. (Standby power is present on the server board when power is turned off but still connected.)
2. Open the server.
3. Move the jumper link from the default operating position (Pins 1-2) to the Reset/Clear position (Pins 2-3) on the appropriate jumper (J1F1 for CMOS Clear or J1H2 for Password Reset).
4. Wait 5 seconds.
5. Move the jumper back to the default position (Pins 1-2).
6. Close the server.
7. Reconnect the power source and power up the server.
8. The password and/or CMOS is cleared and can be reset in BIOS setup.

3.4.1.3 BMC Force Update Procedure

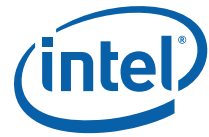
When performing a standard BMC firmware update procedure, the update utility places the BMC into an update mode, allowing the firmware to load safely onto the flash device. If the BMC firmware update process fails because the BMC was not in the proper update state, the server board provides a BMC Force Update jumper that forces the BMC into the proper update state. If the standard BMC firmware update process fails, the following procedure should be followed:

1. Power down the server and remove the power cable. (Standby power is present on the server board when power is turned off but still connected.)
2. Open the server.
3. Place a jumper on the J1E3 header.
4. Close the server.
5. Reconnect the power source and power up the server.
6. Perform the BMC firmware update procedure that is documented in the README.TXT file that is included with the BMC Firmware Update package.

Note: After completing of the firmware update process, the firmware update utility may generate an error message that states that the BMC is still in update mode.

7. Power down the server and remove the power cable.
8. Open the server.
9. Remove jumper from J1E3.
10. Close the server.
11. Reconnect power source and power up the server.

Note: Normal BMC functionality is disabled when the Force BMC Update jumper is populated. The server should never be run with the BMC Force Update jumper populated and should only be used when the standard firmware update process fails. This header should remain unpopulated by default when the server is running normally.



3.4.1.4 BIOS Select Jumper

The jumper block at J1G1 is used to select which BIOS image the system will boot to. Pin 1 on the jumper is identified with a “▼”. This jumper should only be moved if you want to force the BIOS to boot to the secondary bank, which may hold a different version of the BIOS.

The rolling BIOS feature of the server board automatically alternates the Boot BIOS to the secondary bank if the BIOS image in the primary bank is corrupted and cannot boot.

3.4.1.5 Serial B Port Configuration Jumper

The rear of the Carrier Grade Server TIGW1U provides an RJ45 connector for the Serial B port, which is intended for direct connection to serial devices such as serial port concentrators using a standard Cat 5 cable.

Serial devices that use RJ45 connectors differ in the signal they require on Pin 7. For example, modems typically require the DSR signal, and serial concentrators may require the DCD signal. Table 3 describes how to use jumper J2A2 to configure the serial port to provide either of these two signals.

Table 3. Serial B Port Configuration Jumper

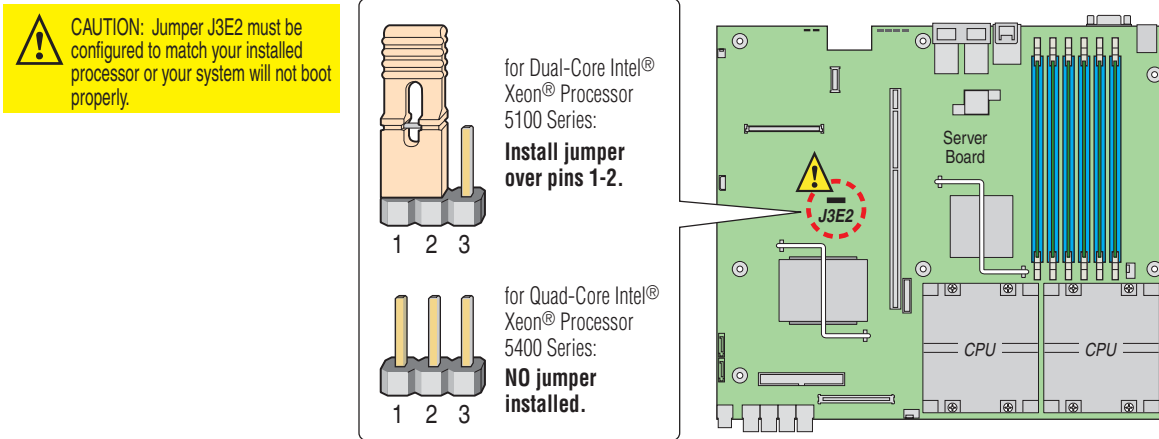
Jumper Name	Pins	Description of Configuration
J2A2: Serial Port	1-2	DCD (Data Carrier Detect) signal routed to Pin 7 of rear RJ45 Serial B port connector. This configuration provides compatibility with Cisco serial concentrators. (Default)
	2-3	DSR (Data Set Ready) signal routed to Pin 7 of rear RJ45 Serial B port connectors. This configuration provides compatibility with standard modems.
Note: Bold entry in “Pins” column indicates default configuration.		

3.4.1.6 Processor Select Jumper

The server board is pre-configured for the Dual-Core Intel® Xeon® processor 5100 series, but the following server system product codes support both the Dual-Core Intel® Xeon® processor 5100 series and the Quad-Core Intel® Xeon® processor 5400 series. These product codes have an “R” in the third position.

- TMRA0201W: Intel® Carrier Grade Server TIGW1U. AC
- TMRD0201W: Intel® Carrier Grade Server TIGW1U. DC

If you have a product with one of these product codes and you want to use a Quad-Core Intel® Xeon® processor 5400 series, you must remove the jumper from pins 1-2 on the processor select jumper. This jumper is located at position J3E2 on the server board. See the following figure.



Regardless of the processor model you install, you must use BIOS version R0085 or later with any server that has one of the above product codes:

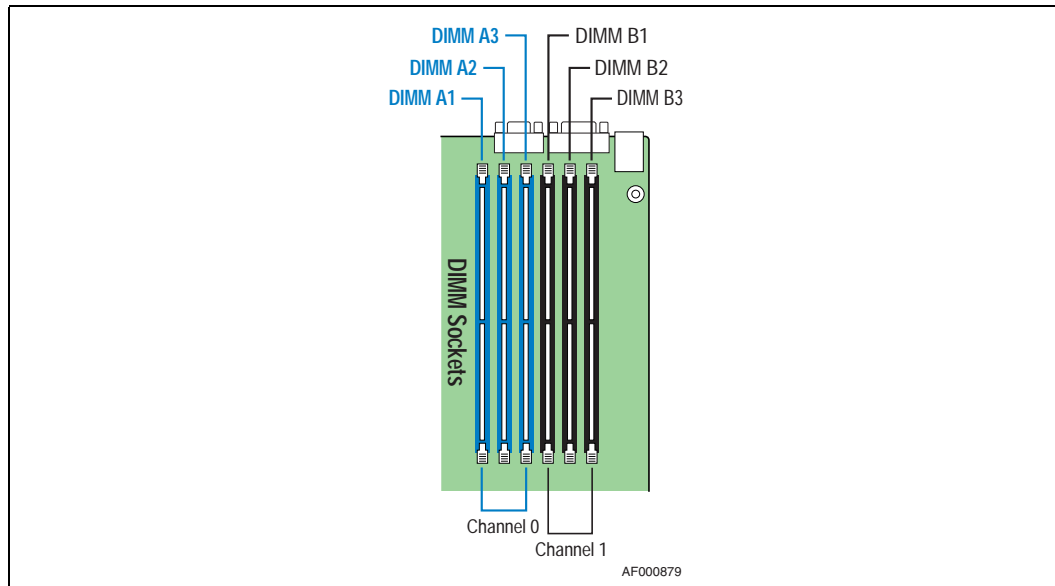
Caution: If your server has one of the above product codes, then configuring it with a BIOS version lower than R0085 will cause system instabilities and your system may not boot.

3.4.2 Configuring Memory DIMMs

The S5000PHB server board supports up to six DDR2-533 or DDR2-667 Fully Buffered DIMMs (FBD memory) in six DIMM slots across two channels, Channel 0 and Channel 1.

Channel 0 consists of DIMM sockets A1, A2, and A3. Channel 1 consists of DIMM sockets B1, B2, and B3. See Figure 18.

Figure 18. DIMM Slots and Channels



The two channels support registered DDR2-533 and DDR2-667 FBDIMM memory (stacked or unstacked). Peak theoretical memory data bandwidth is 6.4 Gbytes/s with DDR2-533 or 8.0 Gbytes/s with DDR2-667.



Table 4 and Table 5 show the maximum memory configurations supported using the specified memory technology.

Table 4. Maximum 6 DIMM System Memory Configuration - x8 Single Rank

DRAM Technology x8 Single Rank	Maximum Capacity
256 Mbit	1.5 Gbytes
512 Mbit	3 Gbytes
1024 Mbit	6 Gbytes
2048 Mbit	12 Gbytes

Table 5. Maximum 6 DIMM System Memory Configuration - x4 Dual Rank

DRAM Technology x4 Dual Rank	Maximum Capacity
256 Mbit	6 Gbytes
512 Mbit	12 Gbytes
1024 Mbit	24 Gbytes
2048 Mbit	48 Gbytes

3.4.2.1 DIMM Population Rules

DIMM population rules depend on the operating mode of the memory controller, which is determined by the number of DIMMs installed. DIMM pairs are populated in the following DIMM slot order: A1 and B1, A2 and B2, A3 and B3.

DIMMs within a given pair must be identical with respect to size, speed, and organization, but DIMM capacities can be different between different DIMM pairs. For example, a valid mixed DIMM configuration may have 512 Mbyte DIMMs installed in DIMM slots A1 and B1, and 1 Gbyte DIMMs installed in DIMM slots A2 and B2. Single DIMM operation is supported with the DIMM populated in slot A1 only, but populating in pairs is recommended.

3.4.2.2 Supported DIMM Configurations

Supported DIMM configurations for this server board are shown in Table 6.

Table 6. FBDIMM Population Options

Channel 0			Channel 1			Sparing Possible
DIMMA1	DIMMA2	DIMMA3	DIMMB1	DIMMB2	DIMMB3	
						NO
						NO
						YES
						NO
■ = Slot is populated. □ = Slot is not populated.						

3.4.2.3 Sparing Mode Memory Configuration

The Memory Controller Hub (MCH) provides memory sparing capabilities. Sparing is a RAS feature that involves configuring a DIMM to be placed in reserve so it can be use to replace a DIMM that fails. The following conditions apply:

- DIMMA1 and DIMMB1 must be identical in organization, size and speed.
- DIMMA2 and DIMMB2 must be identical in organization, size and speed.
- DIMMA1 and DIMMA2 need not be identical in organization, size and speed.
- DIMMB1 and DIMMB2 need not be identical in organization, size and speed.
- Sparring should be enabled in the BIOS setup; the BIOS will configure Rank Sparring Mode.
- The larger of the pairs {DIMMA1, DIMMB1} and {DIMMA2, DIMMB2} will be selected as the spare pair unit.

3.4.3 Installing and Removing Memory DIMMs

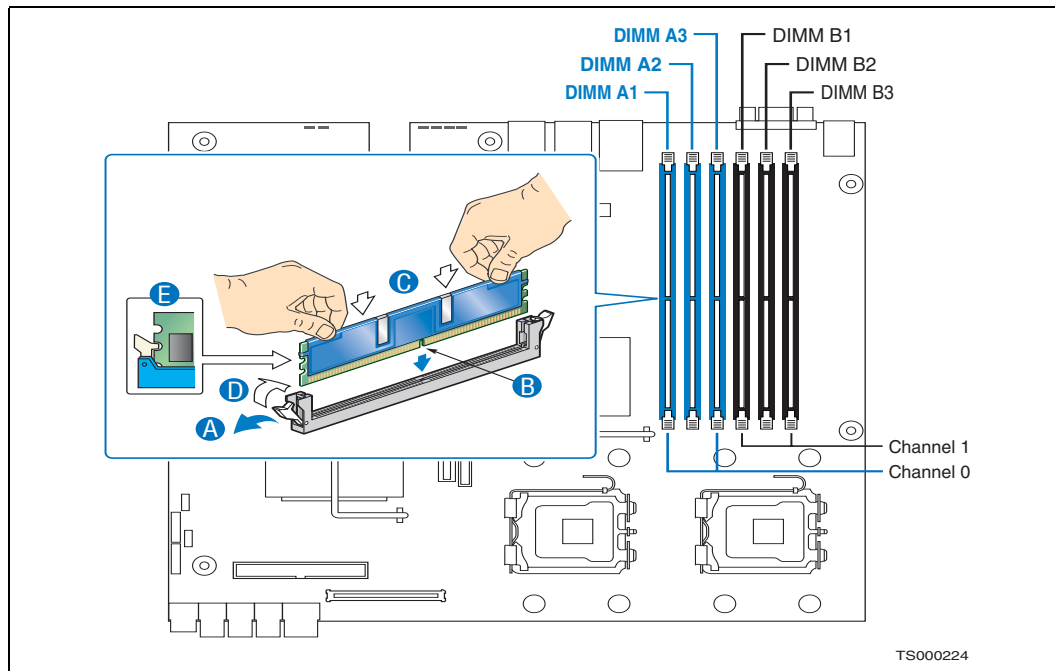
The silkscreen on the board for the DIMMs displays DIMMA1, DIMMA2, DIMMA3, DIMMB1, DIMMB2 and DIMMB3, starting from the inside (left side) of the server board. DIMMB3 is the socket closest to the outside edge of the server board.

3.4.3.1 Installing DIMMs

To install DIMMs, follow these steps:

1. Remove the air duct. For instructions, see Section 3.2.5, “Removing the Processor Air Duct” on page 24.
2. Locate the DIMM sockets on the server board and select the socket where you want to install the DIMM. (See Figure 9 and Figure 19.)

Figure 19. Installing Memory DIMMs



3. Open both DIMM socket levers. (“A” in Figure 19)
4. Note the location of the alignment notch. (“B”)
5. Insert the DIMM making sure the connector edge of the DIMM aligns correctly with the slot. (“E”)



6. Using both hands, push down firmly and evenly on the DIMM until it snaps into place and both levers close. (“C” and “D”)
IMPORTANT: Visually check that each latch is fully closed and correctly engaged with each DIMM edge socket.
7. Replace the processor air duct and the chassis cover if you have completed all work inside of the server.

3.4.3.2 Removing DIMMs

To remove or replace a DIMM, follow these steps:

1. Remove the processor air duct. For instructions, see Section 3.2.5, “Removing the Processor Air Duct” on page 24.
2. Locate the DIMM(s) and select the one to be removed or replaced. See Figure 19.
3. Open the DIMM socket levers.
4. Holding the DIMM by the edges with both hands, lift it away from the socket and store it in an anti-static package.
5. If you are replacing the DIMM, follow the instructions in Section 3.4.3.1, “Installing DIMMs” on page 34.
6. Replace the chassis cover if you have completed all work inside of the server.

3.4.4 Adding or Replacing a Processor

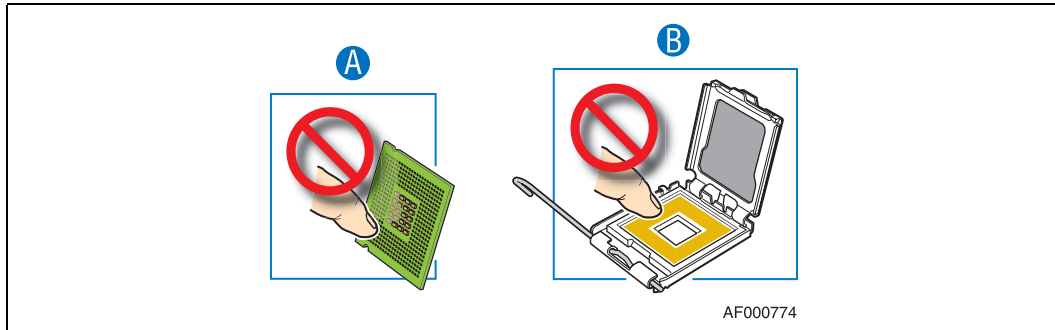
Note: Use the instructions below to add or replace a processor instead of using the instructions that came with the processor.

Caution: The processor must be appropriate: You could damage the server board if you install a processor that is inappropriate for your server. Go to <http://support.intel.com/support/telecom/computeboards/nsw1u/> for a list of compatible processors for the Carrier Grade Server TIGW1U.

3.4.4.1 ESD and Handling Processors

- When opening a socket, do not touch the gold socket wires.
- When unpacking a processor, hold it only at the edges to avoid touching the gold contacts.
- Reduce the risk of electrostatic discharge (ESD) damage to the processor by doing the following:
 - Touch the metal chassis before touching the processor or server board.
 - Keep part of your body in contact with the metal chassis to dissipate the static charge while handling the processor.
 - Avoid moving around unnecessarily.
 - Use a ground strap attached to the front panel (with the bezel removed.)

Figure 20. Cautions for Handling Processors



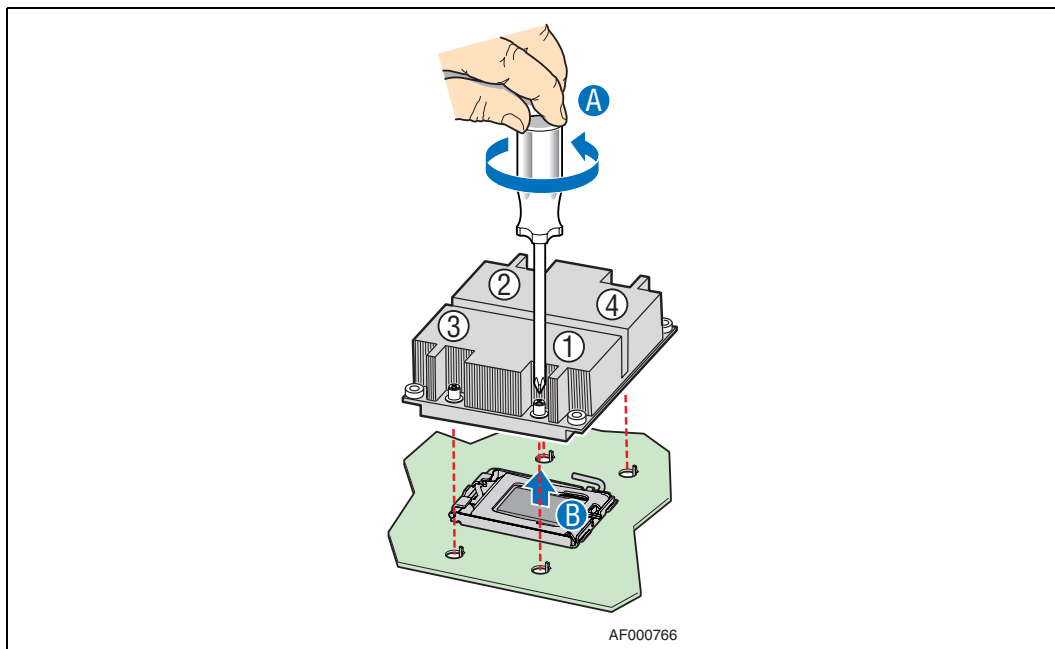
Follow the instructions below to remove and then install a processor, referring to Figure 21 through Figure 27.

3.4.4.2 Removing a Processor

1. Remove the processor air duct that covers the processor. For instructions, Section 3.2.5, "Removing the Processor Air Duct" on page 24.
2. Loosen the four captive screws on the corners of the heat sink ("A" in Figure 21).
3. Twist the heat sink slightly to break the seal between the heat sink and the processor. ("B")
4. Lift the heat sink from the processor. If it does not pull up easily, twist the heat sink again.

Note: Do not force the heat sink from the processor. Doing so could damage the processor.

Figure 21. Removing the Heat Sink



5. Open the socket by pushing the lever handle down and away from the socket to release it. ("A" and "B" in Figure 22)

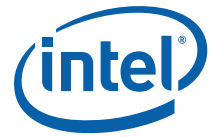
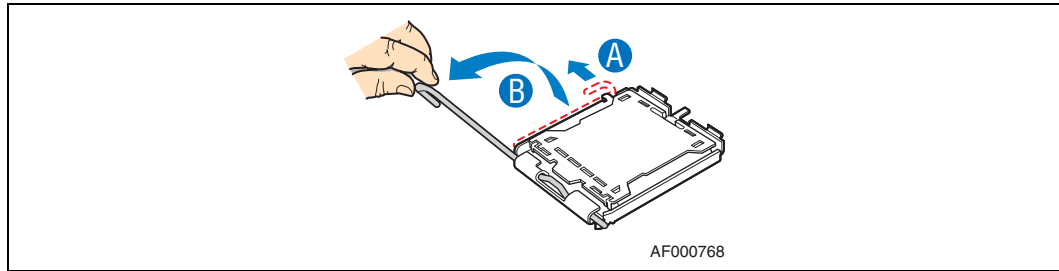
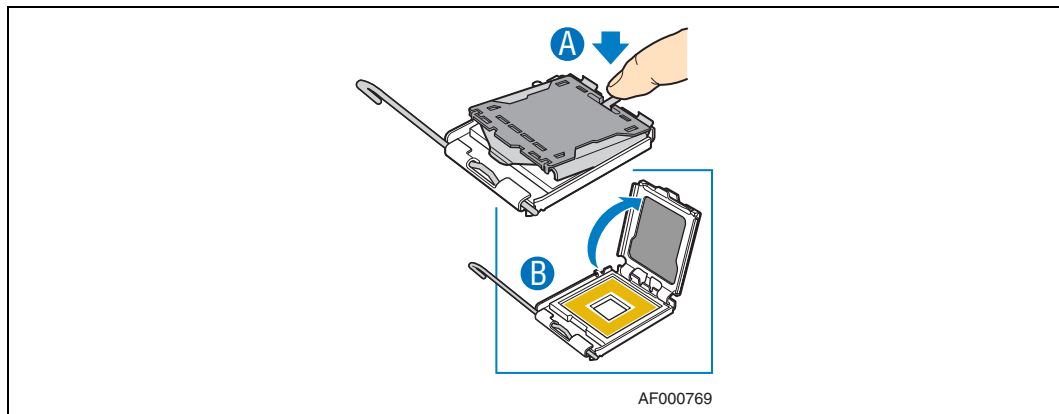


Figure 22. Using the Socket Lever



6. Pull the lever and open the load plate all the way. ("A" and "B" in Figure 23)

Figure 23. Opening the Load Plate



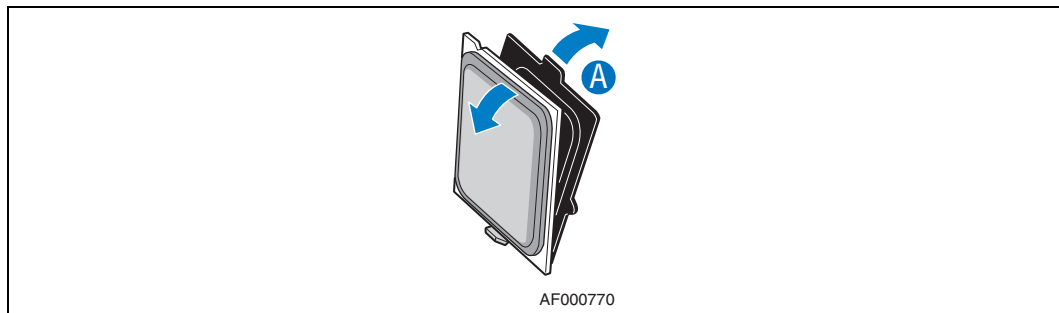
7. Remove the processor.

3.4.4.3 Installing a New Processor

To install a processor, follow these instructions:

1. Take the processor out of its packaging and remove the protective shipping cover. ("A" in Figure 24)

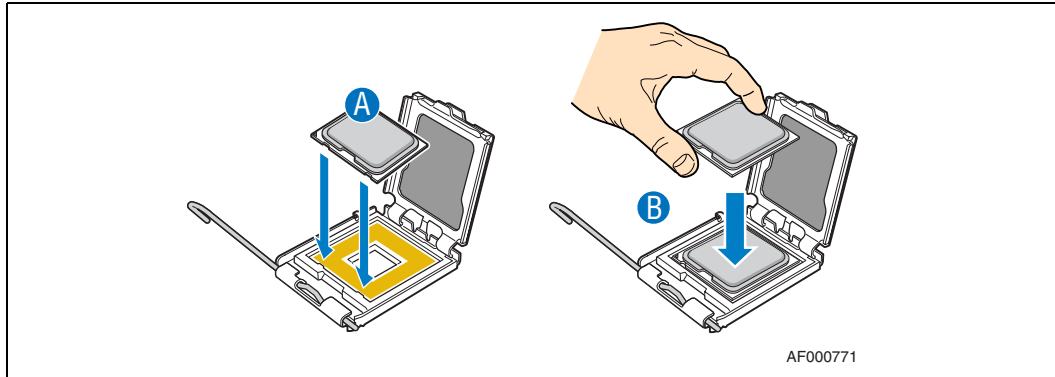
Figure 24. Removing the Processor from its Shipping Cover



Caution: The underside of the processor has components that may damage the socket pins if installed improperly. The processor must align correctly with the socket. Set the processor carefully into the socket!

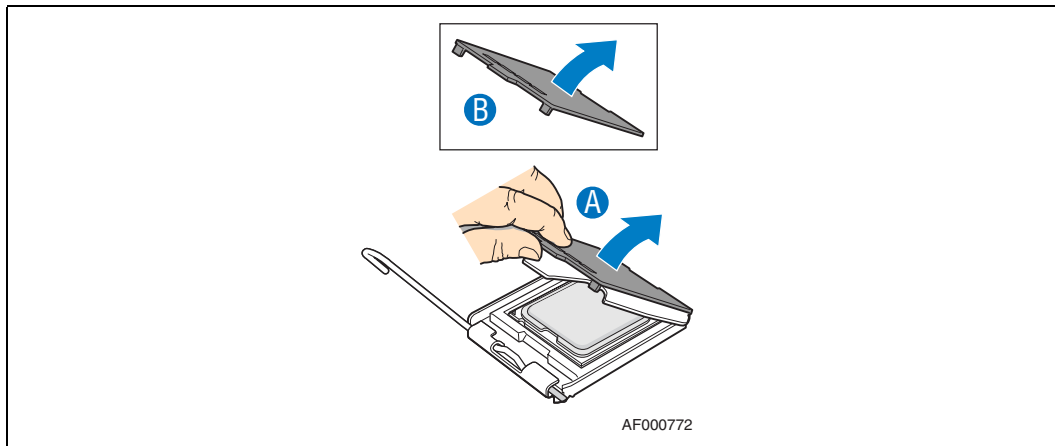
2. Orient the processor with the socket so that the processor cutouts match the socket notches. ("A" in Figure 25)
3. Insert the processor into the socket. ("B")

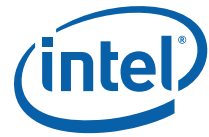
Figure 25. Installing the Processor in the Processor Socket



4. Remove the socket protective cover by grasping the cover tab and pulling away from the load plate. Store the protective cover for future use. ("A" and "B" in Figure 26)

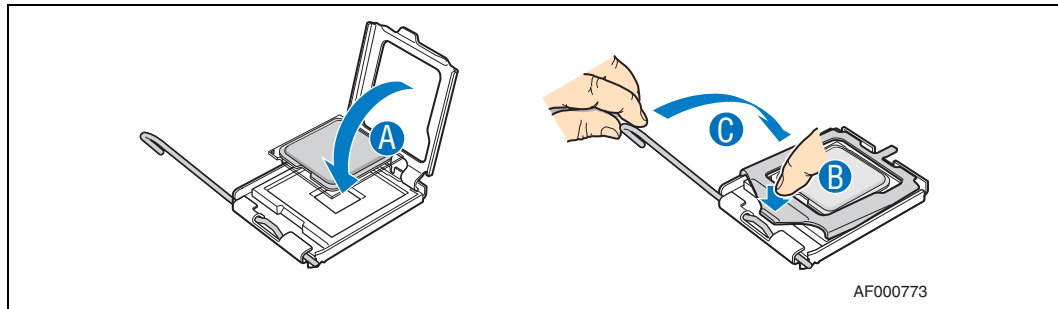
Figure 26. Removing the Socket Protective Cover





5. Close the load plate. (Figure 27, “A”)

Figure 27. Closing the Processor Load Plate and Socket Lever



6. Close the socket lever and ensure that the load plate tab engages under the socket lever when fully closed. (“B” and “C”)

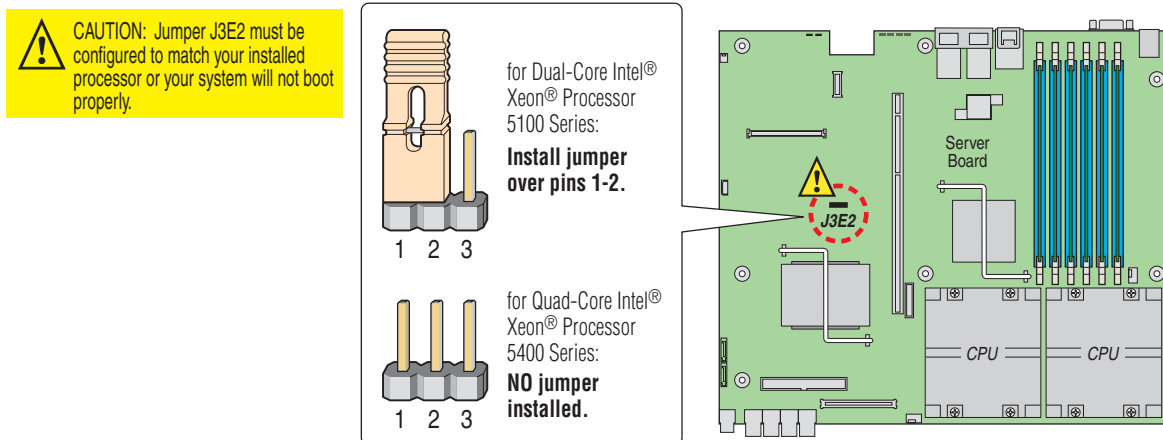
3.4.4.4 Setting the Processor Select Jumper

The server ships pre-configured for the Dual-Core Intel® Xeon® processor 5100 series. To use a Quad-Core Intel® Xeon® processor 5400 series, you must appropriately configure the processor select jumper.

- For a Dual-Core Intel® Xeon® processor 5100 Series, make sure the jumper is installed on pins 1-2 on the processor select jumper.
- For a Quad-Core Intel® Xeon® processor 5400 series, remove the jumper.

Caution: Never install the processor select jumper on pins 2-3. Your system will not boot if these pins are jumpered.

This jumper is located at position J3E2 on the server board. See the following figure.



3.4.4.5 Installing the Heat Sink

1. If this is a new heat sink (not one you removed in Section 3.4.4.2), remove the protective film from the Thermal Interface Material (TIM) located on the bottom of the heat sink, if present.



2. Set the heat sink over the processor, lining up the four captive screws with the four posts surrounding the processor. Align the heat sink fins to the front and back of the chassis for correct airflow (front to back). Use caution and make sure that cables are not pinched beneath the heat sink. (See Figure 21.)
3. Loosely screw in or finger tighten the captive screws on the heat sink corners in a diagonal manner. Do not fully tighten one screw before tightening another.
4. Gradually and equally tighten each captive screw until each is firmly tightened.

3.4.5 Installing or Replacing a PCI Add-in Card

The riser card assembly is installed in the super slot located in the middle of the S5000PHB server board. (See Figure 7 for this location.) The system is delivered with a PCI-X* riser card attached to the riser card assembly. To use PCI Express* (PCIe*) cards, this riser must be replaced with the PCIe riser card, which can be ordered as an accessory.

Note: PCI / PCI-X / PCI Express add-in cards are referred to generically as “PCI cards” in the following procedures.

To add a PCI card, remove the riser card assembly from the system. Ensure that the appropriate riser card is attached to the assembly (PCI/PCI-X by default) or replace it with the correct one (e.g, PCIe instead of PCI-X), remove the I/O filler panel, then add the PCI or PCIe add-in card. This assembly is then plugged back into the super slot connector on the S5000PHB server board. Refer to the *Intel® Server Board S5000PHB Technical Product Specification* for the electrical characteristics for the PCI/PCIe riser card assembly super slot.

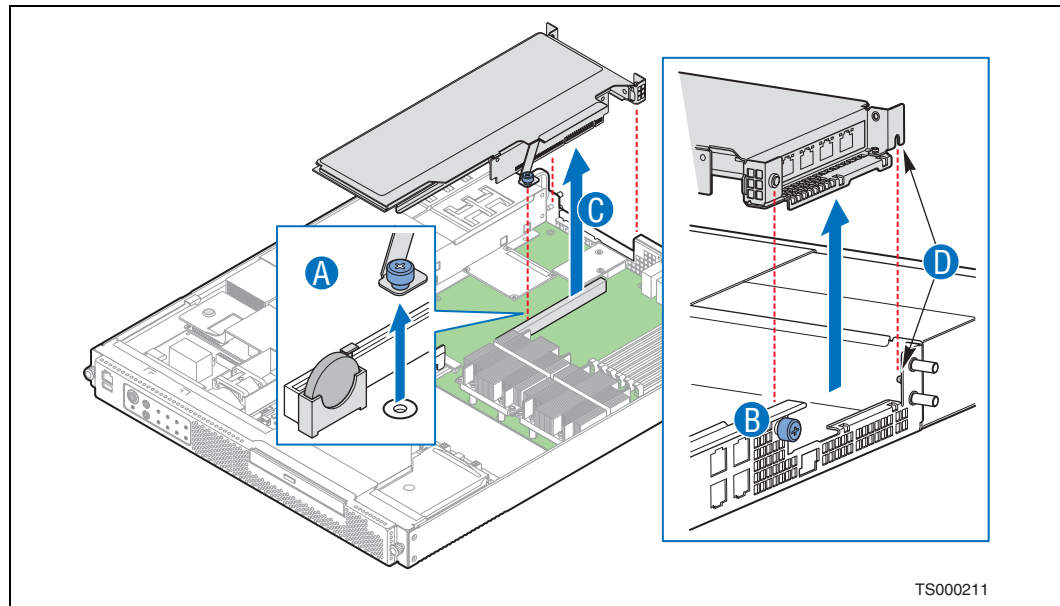
Note: Use a supported PCI/PCIe card. See the *Tested Hardware and Operating System List* (THOL) at <http://support.intel.com/support/telecom/computeboards/tigw1u/> for a list of tested and supported cards.

3.4.5.1 Removing the PCI Riser Card Assembly

To remove an installed riser card assembly, follow these steps:

1. Loosen the blue captive screw that secures the riser card assembly to the server board. (“A” in Figure 28)
2. Loosen the blue captive thumb screw on the rear panel of the chassis. (“B”)
3. Lift the riser card assembly straight up and remove it from the chassis. (“C”)

Figure 28. Removing the Riser Card Assembly

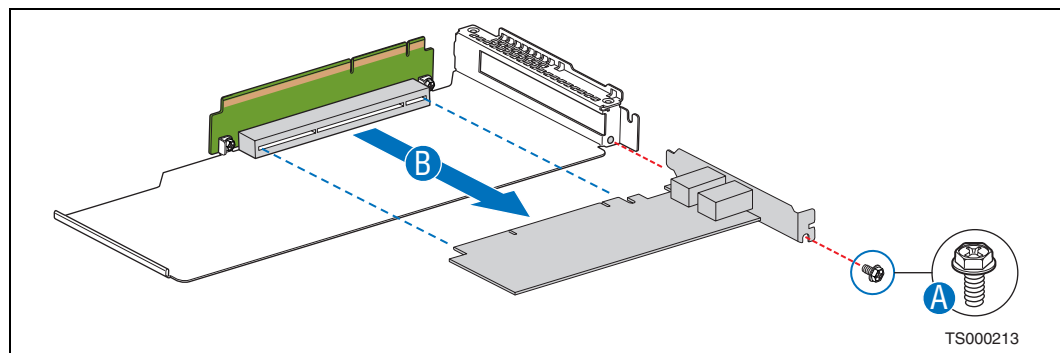


3.4.5.2 Removing a PCI card from the Riser Card Assembly

Caution: When handling a PCI card, observe safety and ESD precautions. See Appendix A, “Safety Information” for more information.

1. Turn the riser card assembly upside-down to remove the PCI card.
2. Remove the rear retention screw from the riser card. (“A” in Figure 29)
3. Detach the PCI card from the riser card connector. (“B”)

Figure 29. Removing a PCI-X Card from the Riser Card Assembly



3.4.5.3 Installing a PCI Card in the Riser Card Assembly

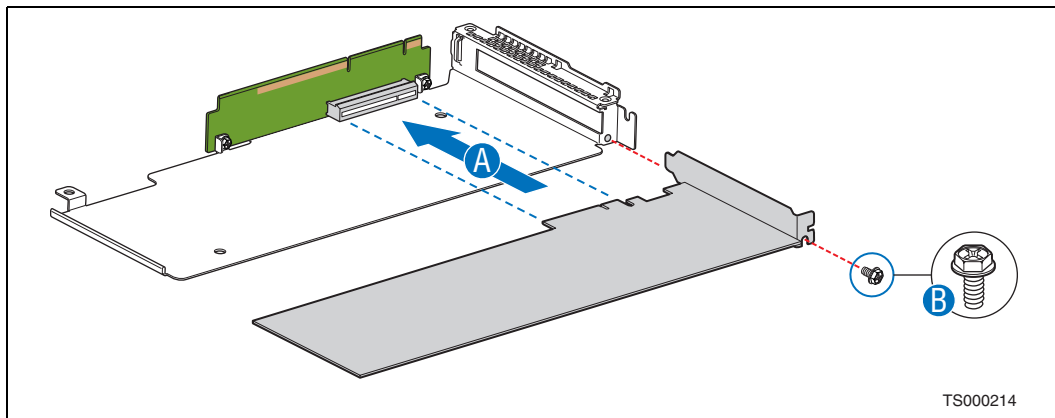
Caution: When handling a PCI card, observe safety and ESD precautions. See Appendix A, “Safety Information” for more information.

The following procedure uses a PCIe card as the example.

1. If the current riser card in the assembly is not correct for the PCI card you are installing, i.e., in this example, the default PCI-X riser card instead of a PCIe riser card, do the following:

- a. With the riser card assembly upside-down, remove the riser card by loosening the two screws that attach it to the riser card assembly sheet metal top.
 - b. Fasten the new riser card, i.e., the PCIe riser card in this example, using the two screws.
2. If the PCI add-in card slot was empty before installing the new card, remove the add-in card filler panel.
 3. With the riser card assembly upside-down, slide the PCI card onto the sheet metal and attach it to the riser card connector. ("A" in Figure 30)
Be sure that the PCI card edge connector is seated in the riser card connector correctly.
 4. Fasten the PCI card to the riser card assembly bracket using the retention screw. ("B")

Figure 30. Adding a PCI Express* Card into the Riser Card Assembly

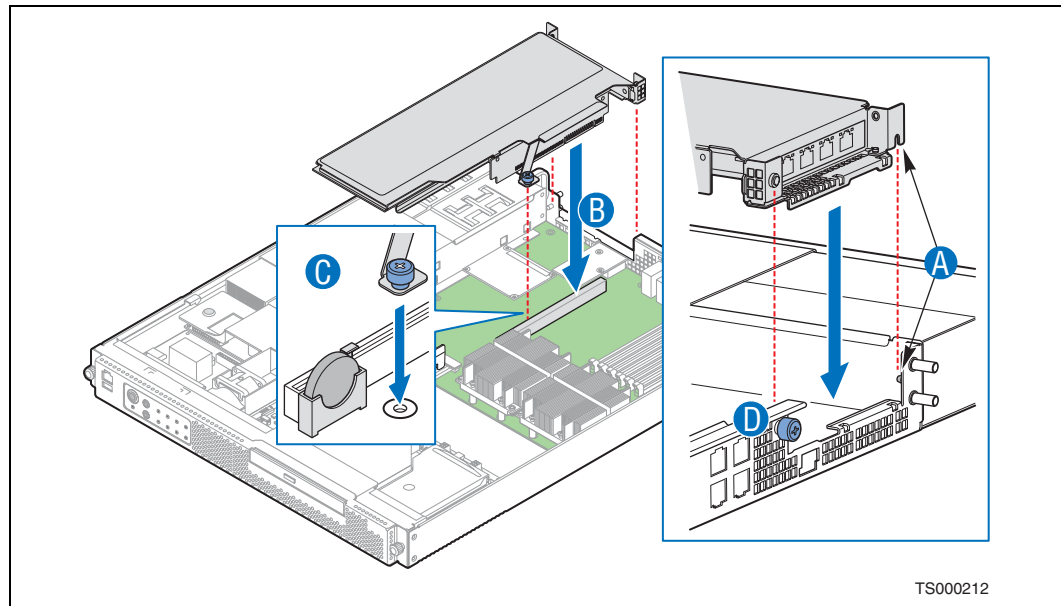




3.4.5.4 Installing the Riser Card Assembly onto the Server Board

1. Align the fork on the riser card assembly with the pin on the rear chassis panel. ("A" in Figure 31)
2. Attach the riser card assembly to the server board by inserting the riser card edge connector into the super slot header on the server board. ("B")
3. Fasten the blue captive screw on the riser card assembly to the server board. ("C").

Figure 31. Reinstalling the Riser Card Assembly



3.4.6 Installing an Intel® Z-U130 Value Solid State Drive

The Intel® Z-U130 Value Solid State Drive (VSSD) is a removable media device that provides local memory storage for options like system information, diagnostic partitions, and configuration data. The Solid State Drive is installed on top of the drive bays in front of the SFP board. See Figure 9 for the cable connector location.

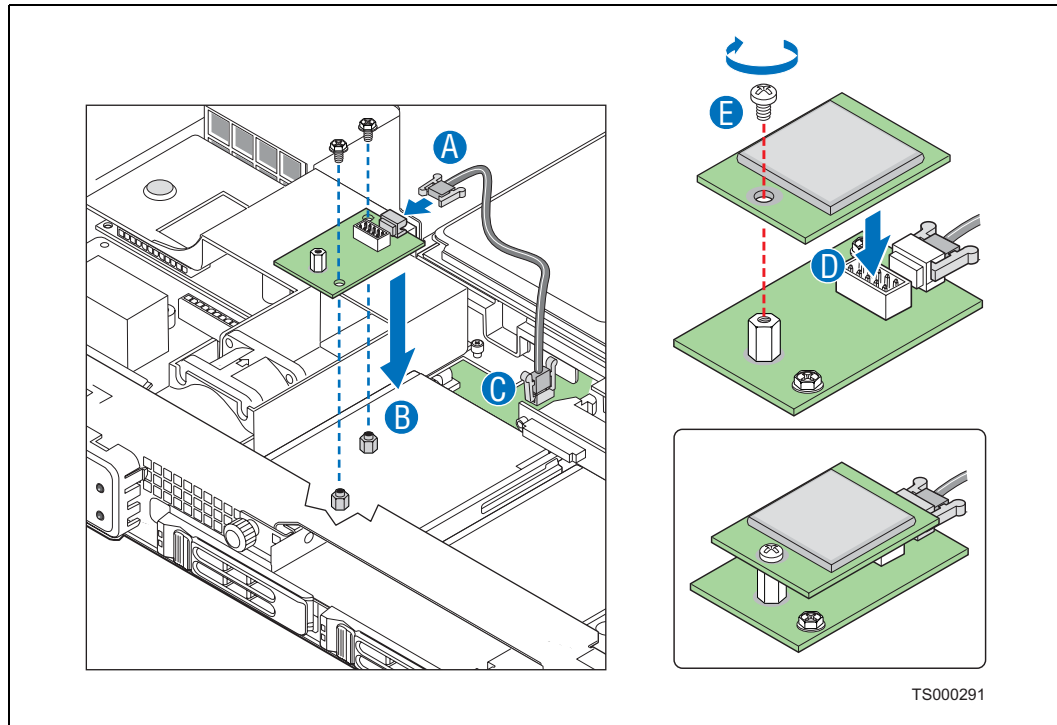
1. Plug one end of the cable labeled “SysCon” into the interposer board. (“A” in Figure 32)

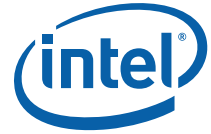
Note:

The connectors on both ends of this cable are identical.

2. Use the two screws to attach the interposer card to the standoffs on top of the drive bay. (“B”)
3. Plug the other end of the SysCon cable into the connector on the SFP board. (“C”)
4. Attach the VSSD to the interposer card. (“D”)
5. Insert and tighten the screw that will secure the VSSD to the interposer card. (“E”)

Figure 32. Installing the Intel® Z-U130 Value Solid State Drive





3.4.7 Installing Hardware RAID Components

The RAID 5 Kit may include the following components for hardware RAID support:

- Intel® RAID Activation Key (required for hardware RAID)
- RAID mini-DIMM (required for hardware RAID)
- Intel® RAID Smart Battery (optional; the Smart Battery is only required to back up the data in the RAID cache in the event of a system power failure)

The hardware RAID 5 components are installed on the SFP board. See Figure 9 for the connector locations.

Please refer to the TIGW1U Spares and Configuration Guide for these parts. The RAID mini-DIMM may also be procured from the list of approved vendors in the Intel® Server Board S5000PHB Tested Memory List.

Note: The supported RAID levels are 0, 1, 5, and 10.

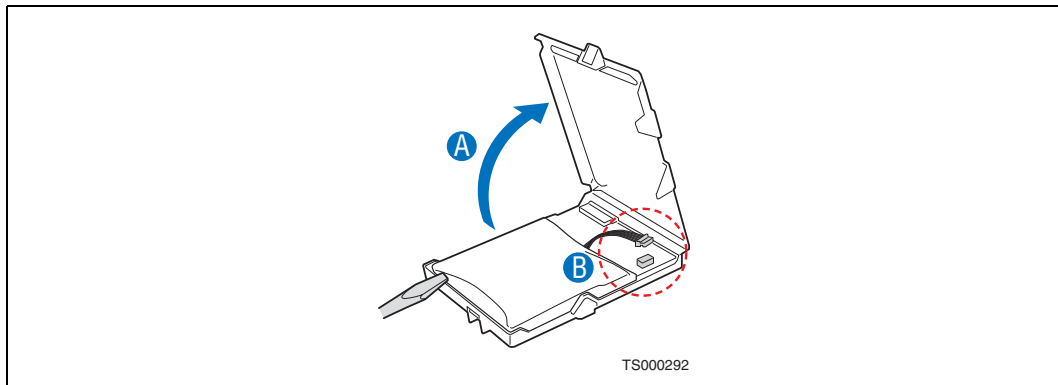
3.4.7.1 Installing the Intel® RAID Smart Battery

The Intel® RAID Smart Battery is located just behind the front panel near HDD drive bay 0. The connector is on the far right end of the SAS Front Panel (SFP) board.

The Smart Battery has an internal battery power cable that must be connected.

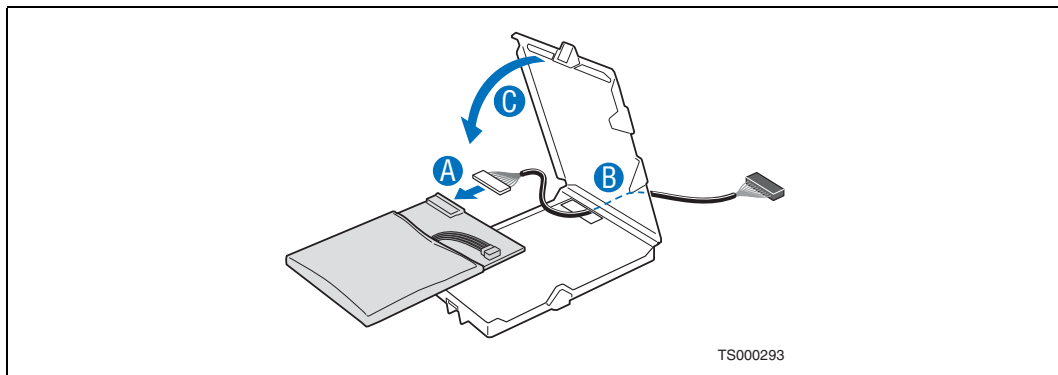
1. Open the Smart Battery case lid. If necessary, use a small flat blade screwdriver to pry open the lid at the corners. (“A” in Figure 33)
2. If the battery power cable is not connected, connect it now. (“B”)

Figure 33. Connecting the Smart Battery Power Cable



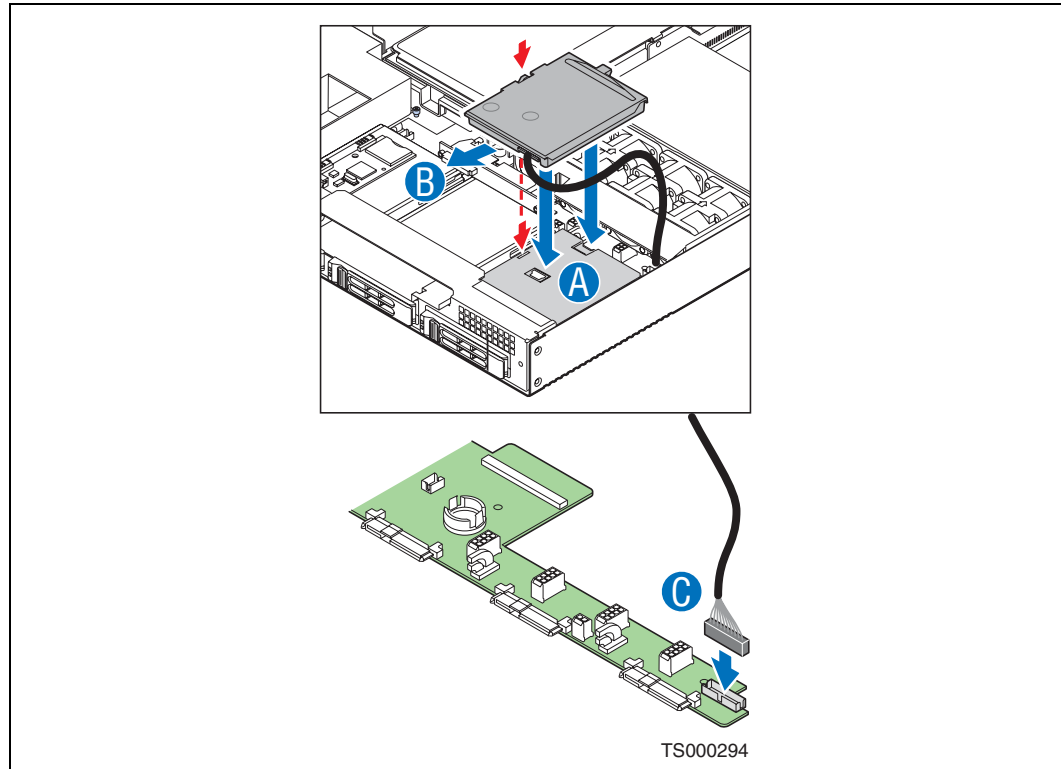
3. Lift the battery assembly out of the case and insert the battery cable through the opening in the bottom of the case. (“B” in Figure 34)
4. Attach the battery cable to the connector on the back of the battery assembly. (“A”)
5. Put the battery assembly back into the case and close and latch the case lid. (“C”)

Figure 34. Connecting the Smart Battery Cable Through the Battery Case



6. Align the two hooks on the underside of the Smart Battery with the matching tabs on the chassis. ("A" in Figure 35)
7. Slide the Smart Battery toward the front panel to lock it in place. ("B")
8. Connect the cable from the Smart Battery to the connector on the SFP board. ("C")

Figure 35. Installing the Smart Battery

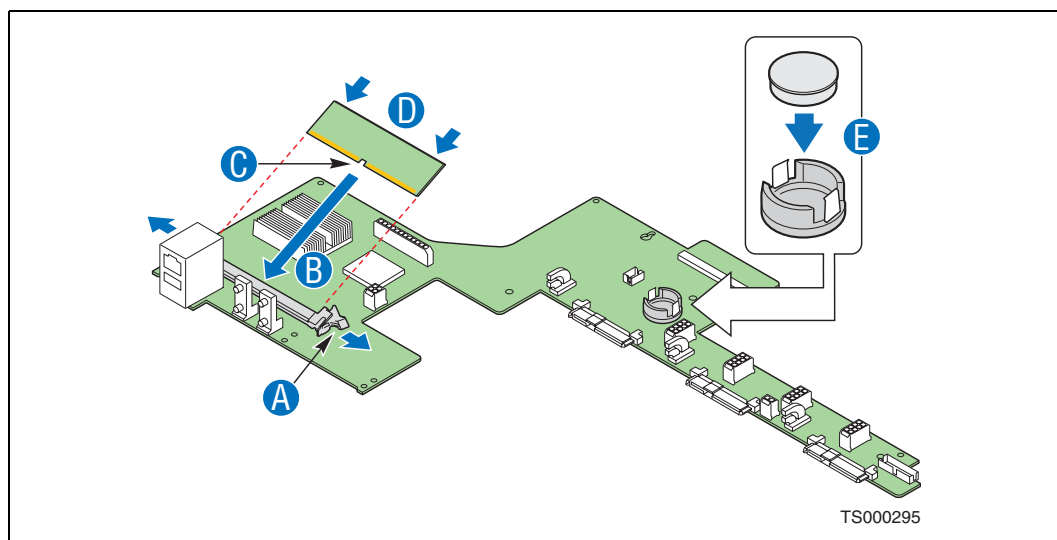


3.4.7.2 Installing the Intel® RAID Activation Key and the ECC Mini-DIMM

The Intel® RAID Activation Key connector and the mini-DIMM slot are located on the SFP board.

1. Open both levers on the RAID mini-DIMM slot. (“A” in Figure 36)
2. Note the location of the notch on the DIMM edge (“C”) and ensure that the DIMM aligns correctly with the slot. (“B”)
3. Using both hands, press down firmly and evenly on the DIMM until it snaps into place and the latches close. (“D”)
4. Insert the Intel® RAID Activation Key into the socket. (“E”)
Make sure that the metal clips on the socket snap over the top edge of the key.

Figure 36. Installing the Intel® RAID Activation Key and Mini-DIMM



3.5 Internal System Component Replacement Procedures

This section provides instructions for replacing internal system components that are not hot-swappable when they fail.

Note: The procedures in this section assume that you have powered down the server and removed the chassis cover as described in Section 3.2, “General Installation Procedures” on page 23.

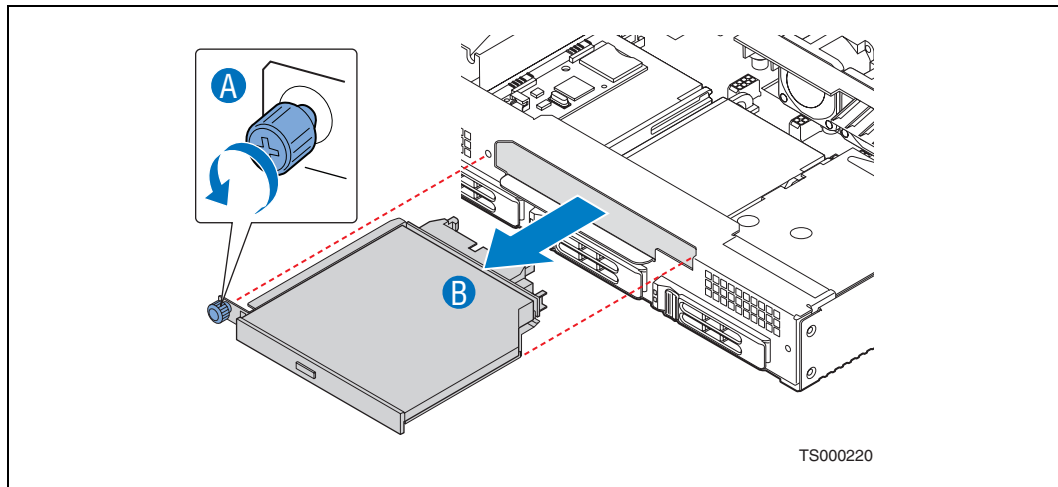
3.5.1 Replacing an Optical Device

A DVD-ROM device comes pre-installed in the Carrier Grade Server TIGW1U. This device is not hot-swappable. To replace the drive, you must first power down the system and remove the chassis cover as described in Section 3.2, “General Installation Procedures” on page 23.

3.5.1.1 Removing the Optical Device Tray from the Chassis

1. Disconnect the power and data connectors from the interposer board on the back of the optical drive.
2. Loosen the blue captive thumbscrew on the optical drive tray. (“A” in Figure 37)
3. Pull the drive tray out of the chassis. (“B”)

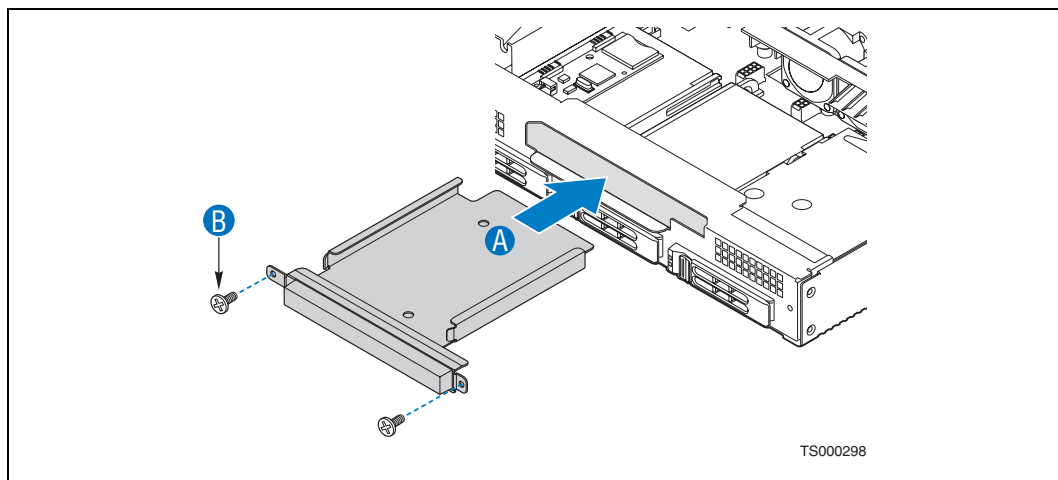
Figure 37. Removing the Optical Device Tray from the Chassis



4. If a new drive will not be used to replace the existing one, install the optical drive filler panel into the drive opening and fasten the two accompanying screws. (“A” and “B” in Figure 38)

Caution: To ensure proper cooling, the optical drive opening cannot be left empty.

Figure 38. Using a Filler Panel in the Optical Drive Tray

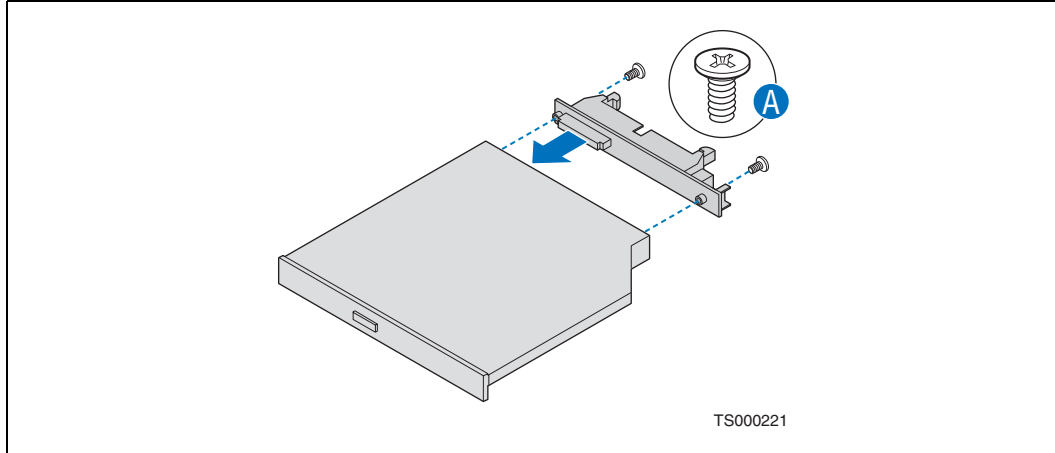


5. Remove the interposer board on the back of the optical drive for use on the new replacement drive.

3.5.1.2 Installing a New Optical Drive

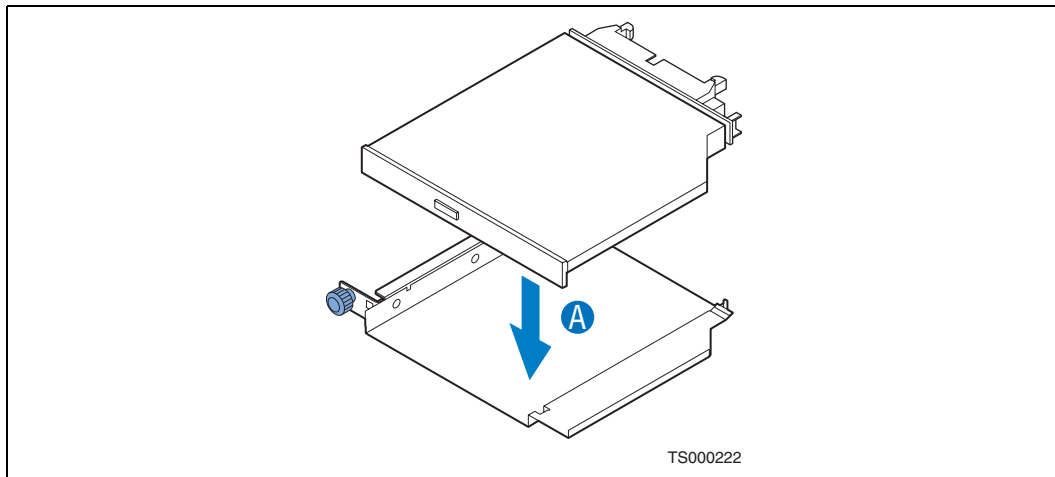
1. Connect the interposer board to the back of the optical drive. ("A" in Figure 39)

Figure 39. Connecting the Optical Drive Interposer Board



2. Place the new optical drive into the drive tray. ("A" in Figure 40)

Figure 40. Installing an Optical Drive in the Drive Tray



3. Insert the optical drive tray back into the chassis and tighten the blue thumbscrew. ("A" and "B" in Figure 41).

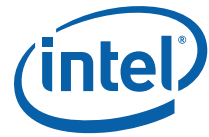
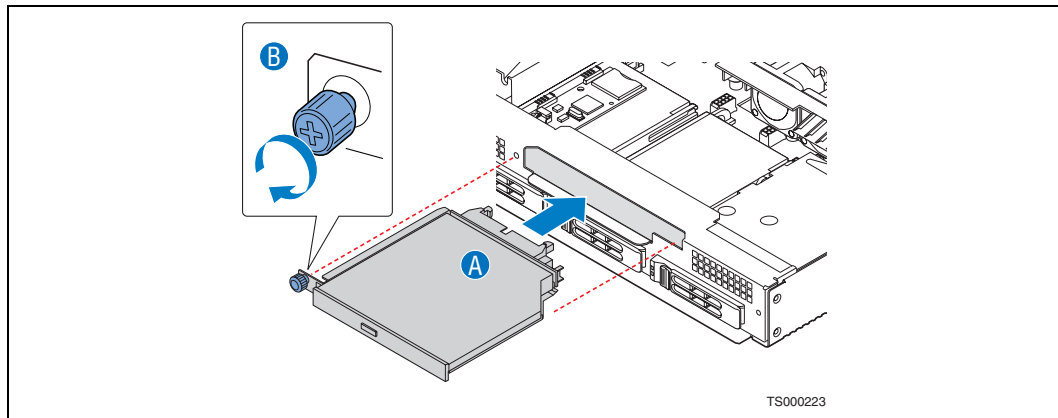


Figure 41. Installing the Drive Tray with Optical Drive Attached into the Server



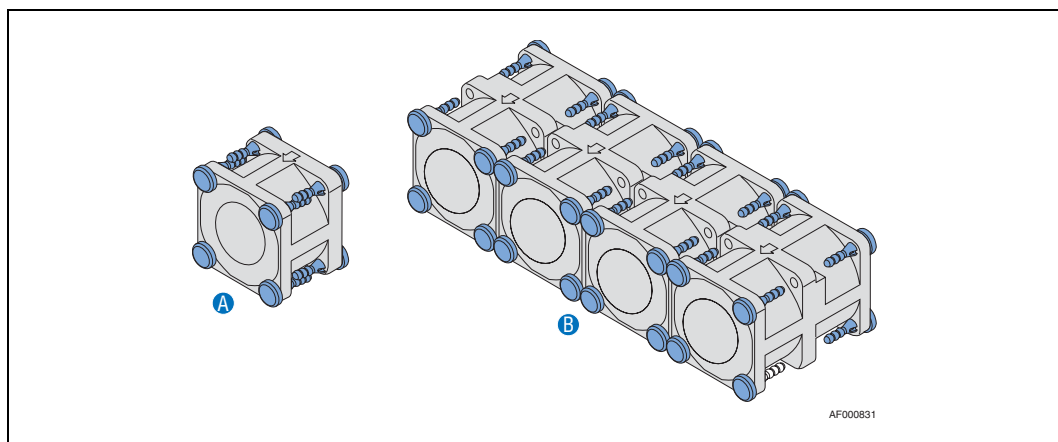
4. Connect the power and data cables back onto the interposer board.
5. If this is the only change you are making, attach the front bezel and cover and reconnect the power to the chassis.

3.5.2 Replacing a Fan Assembly

Caution: Your server does not have hot-swappable fans. Before replacing any of the fans, you must first take the server out of service, turn off all peripheral devices connected to the system, turn off the system by pressing the power button, and unplug the AC power cord from the system or wall outlet.

The replacement/spare fan set consists of one PCI fan and four dual-rotor CPU fans plus enough resilient fan bumpers for all five fans. The bumpers are used to isolate fan vibration from the rest of the system.

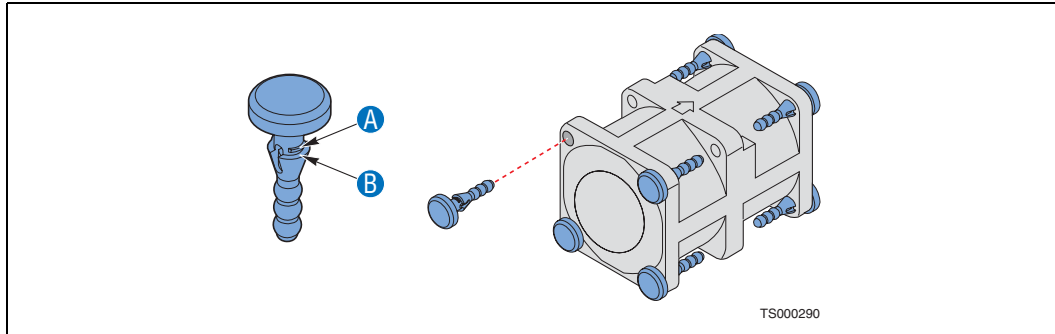
Figure 42. PCI Fan and Four-Fan Set (with Bumpers Installed)



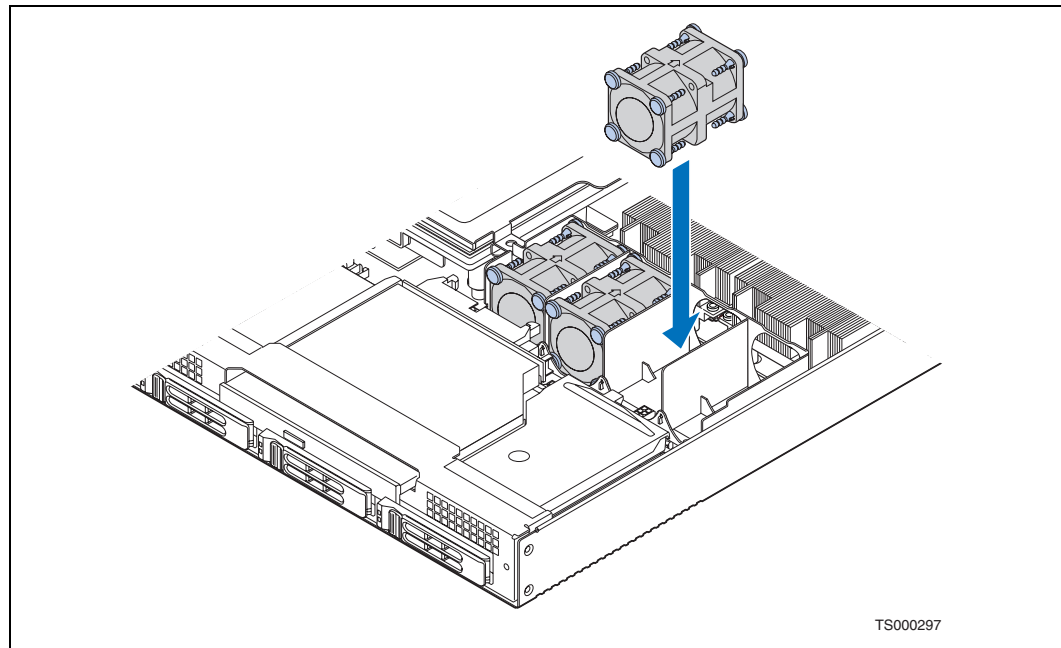
3.5.2.1 Replacing the CPU Four-Fan Assembly

1. Remove the processor air duct that covers the processor and cooling area behind the drive trays. For instructions, see Section 3.2.5, “Removing the Processor Air Duct” on page 24.
2. Disconnect the four fan power cables from the SAS front panel (SFP) board by squeezing the latch on each of the four fan cable connectors. See Figure 9 for the locations of these connectors.
3. Remove all four fans from their pockets in the fan bracket.
4. Insert one of the blue fan bumpers into each of the eight mounting holes on all four dual-rotor fans.
The locking shoulder will catch on the flange to fasten the bumper to the fan. (“A” in Figure 43)

Figure 43. Installing the Fan Bumpers



5. Align the fans with the arrow on top facing the rear of the chassis.
6. Push each of the four fans into one of the pockets in the four-fan assembly bracket. (See Figure 44)

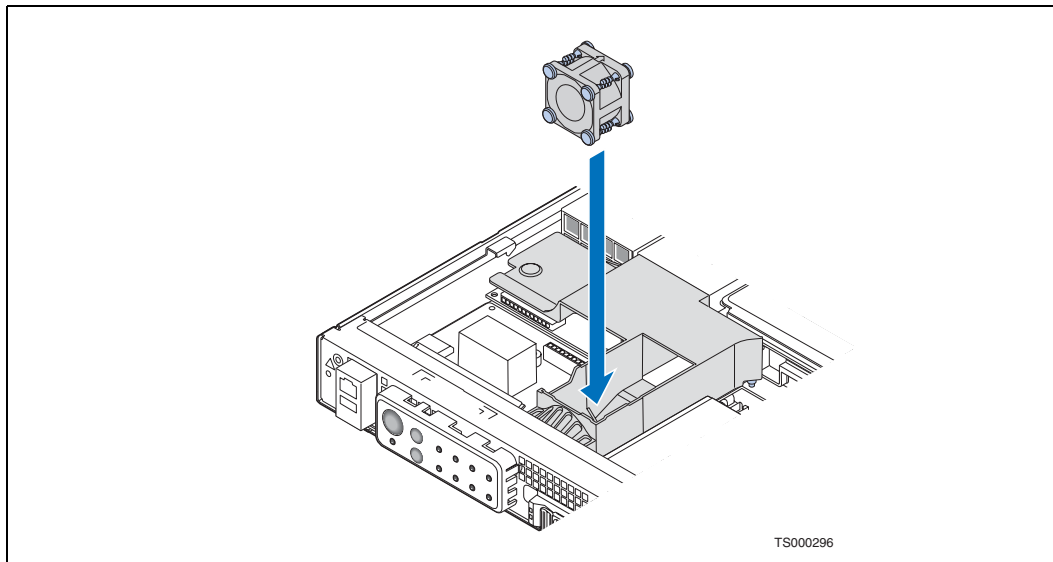
Figure 44. Installing Fans into the Four-Fan Assembly Bracket

7. Connect the fan cables to the correct fan connectors on the SFP board. The fan connectors are labeled on the SFP board.

3.5.2.2 Replacing the PCI Fan

1. Disconnect the PCI fan power cable from the SAS front panel (SFP) board by squeezing the latch on the fan cable connector. See Figure 9 for the location of this connector.
2. Remove the fan from the fan bracket.
3. Insert one of the blue fan bumpers into each of the four mounting holes on the PCI fan.
The locking shoulder will catch on the flange to fasten the bumper to the fan. ("B" in Figure 43)
4. Align the fan with the arrow on top facing the rear of the chassis.
5. Push the PCI fan into the fan bracket.

Figure 45. Installing the PCI Fan into the Bracket



6. Connect the fan cable to the connector on the SFP board.

3.5.3 Replacing the SAS Front Panel Board

The SAS Front Panel (SFP) board provides an interface to the controls at the front of the system, the power interconnect for the server board, the USB2 and Serial B interface, and the front panel LED interface connections. It also houses the optional hardware RAID5 components and optional Intel® Z-U130 Value Solid State Drive.

Caution: When handling this board, observe safety and ESD precautions. (See Appendix A, “Safety Information” for more information.)

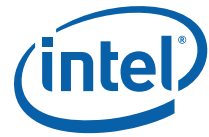
To replace the SFP board, the following components must be removed:

- All cable connections on the SFP board and selected connections from other board components
- PCI fan assembly and air duct
- CPU four-fan assembly and air duct
- LED light pipes to the front panel

Caution: Before replacing any of the Carrier Grade Server TIGW1U boards, you must first take the server out of service, turn off all peripheral devices connected to the system, turn off the system by pressing the power button, and unplug the power cord from the system or wall outlet.

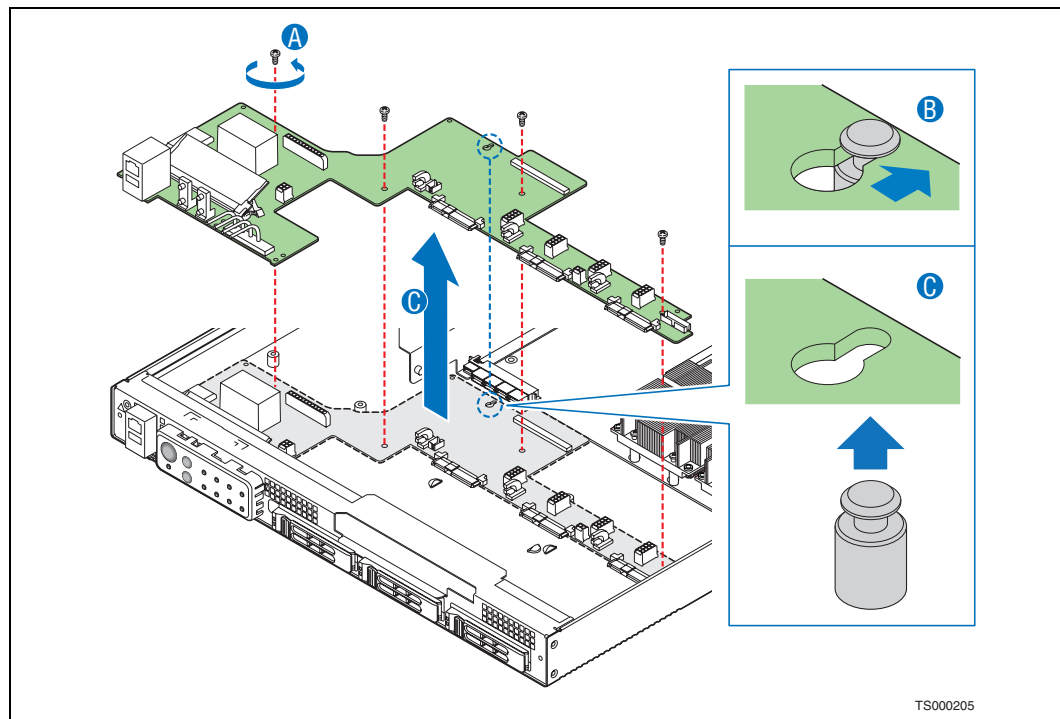
3.5.3.1 Removing the SAS Front Panel (SFP) Board

1. Power down the server system and unplug all peripheral devices and the power cable.
2. Remove the chassis cover.
3. Remove the PCI fan assembly, including the bracket and air duct.



4. Remove the CPU four-fan assembly, including the bracket and air duct.
5. Disconnect these cables from the SFP board:
 - Front panel data
 - Front panel USB
 - All fan power cables
 - Flex cable
 - Optical device power cable
 - Power interconnect to PDB
6. Remove the screws (“A”).
7. Gently work the SFP board backward (“B”), toward the rear of the chassis to disengage the light pipe from behind the front control panel bezel.
8. Pull the front panel board up over the placement pegs (“C”) and lift it from the chassis.
9. Remove any other components you have installed on the SFP board, such as a Intel® RAID Smart Battery, Intel® RAID Activation Key, and mini-DIMM. Set them aside for re-installation on the new replacement SFP board.

Figure 46. Removing the SFP Board



3.5.3.2 Replacing the Light Pipe Assembly

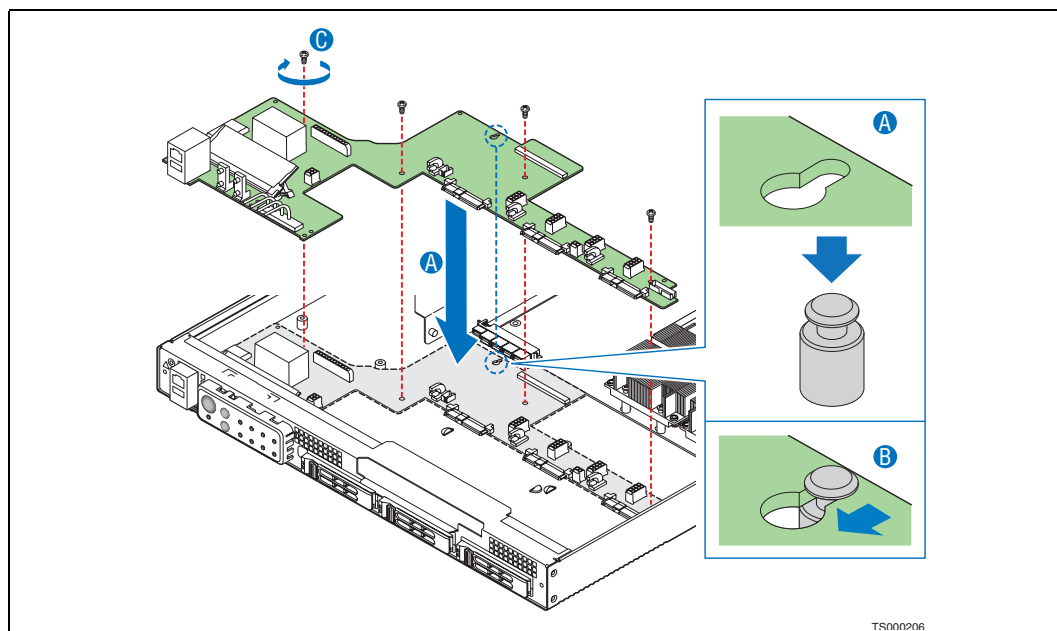
To replace the light pipe assembly on an existing SFP board, use the following instructions, but replace the existing SFP board instead of installing a board:

- Removing the SAS Front Panel (SFP) Board
 - Replacing the Light Pipe Assembly (the steps below)
 - Installing the SFP Board
1. Note the position of the light pipe assembly so you can later correctly position it on the SFP board during the re-installation process. The pipes extend outward from the SFP board to the front panel control panel.
 2. Remove the light pipe assembly by gently pressing the four plastic clips from the underside of the SFP board until the bottom of the clips are flush with the bottom of the SFP board.
 3. Ease the light pipe assembly from the SFP board.
 4. Insert the four plastic clips on the light pipe assembly into the matching holes in the new SFP board. Insert the clips gently and evenly; do not insert one clip fully without first partially pressing the others into place.

3.5.3.3 Installing the SFP Board

1. Lower the SFP board into the chassis.
2. While holding the rear edge of the board, ease the board forward, sliding the serial port and USB port connector assembly through the matching cutout at the front panel of the chassis.
3. Lower the rear of the board into position, fitting the board over the placement pegs. ("B")
4. Pull the board forward, locking the board onto the placement pegs. ("B")
5. Replace the screws you removed earlier. ("C")

Figure 47. Installing the SFP Board





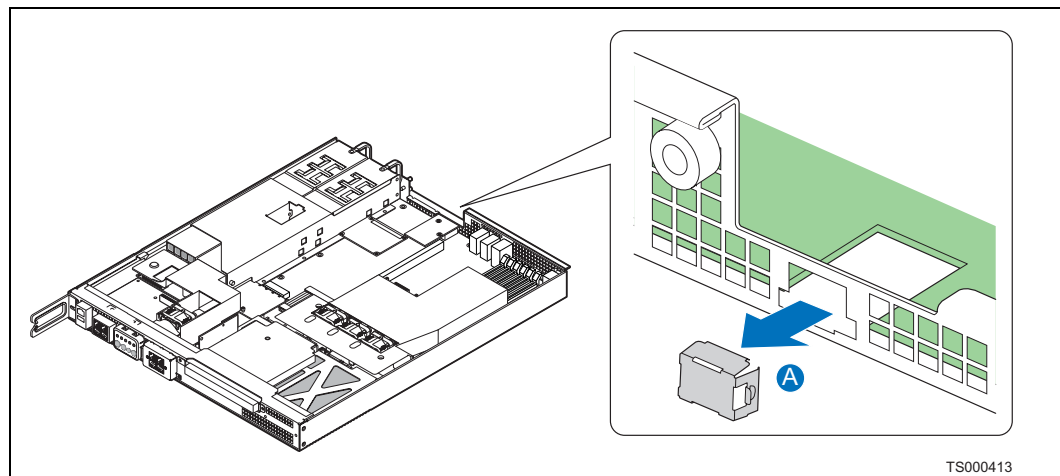
3.5.4 Installing the Intel® Remote Management Module 2

To install the GCM module and the Intel® Remote Management Module 2 (Intel® RMM2), you must first remove the chassis top cover, the processor air duct, and PCI riser card assembly. For instructions, see Section 3.2.1, “Removing the Chassis Cover” on page 23, Section 3.2.5, “Removing the Processor Air Duct” on page 24, and Section 3.4.5.1, “Removing the PCI Riser Card Assembly” on page 40.

3.5.4.1 Installing the GCM Module

1. Remove the filler panel from the rear panel of the chassis by squeezing the side edges and pushing it out from inside the chassis. (Figure 48, “A”)
2. Snap the two standoffs into the S5000PHB server board. (Figure 49, “C”)
3. Attach the GCM module to the server board using the connector. (“D”)

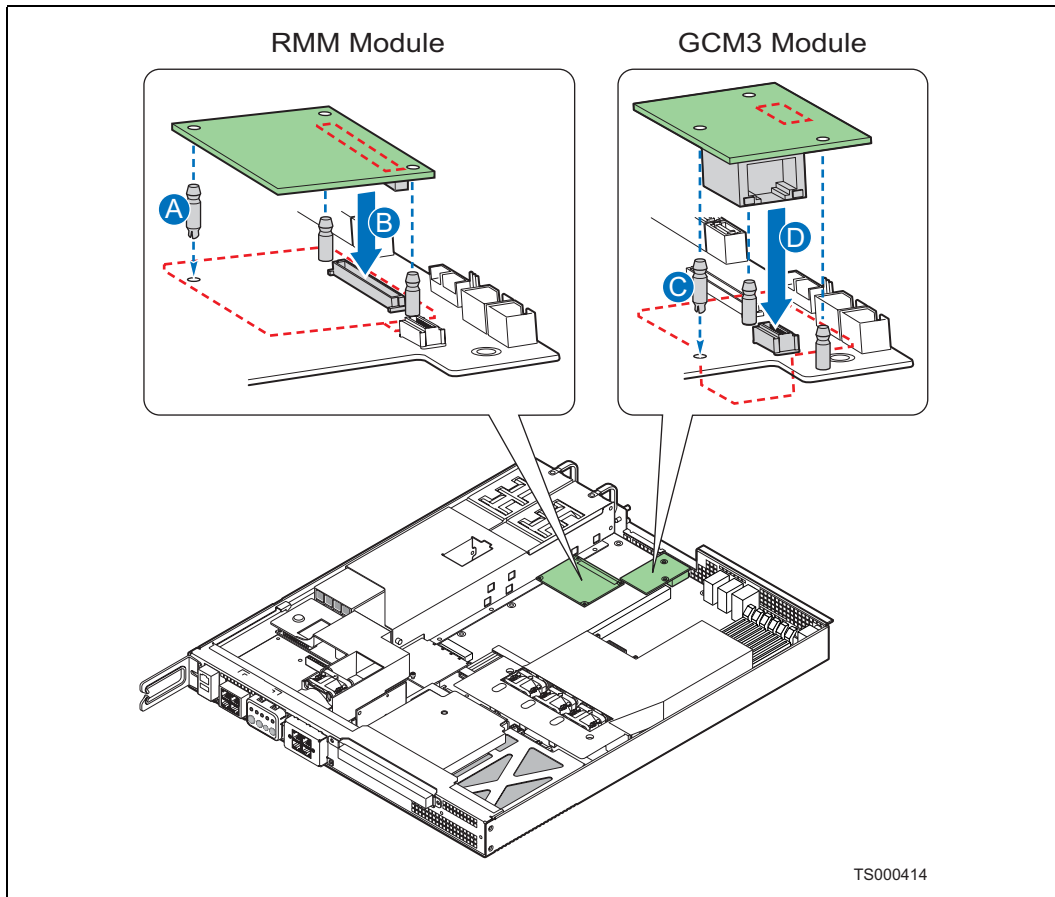
Figure 48. Removing the GCM Port Filler Panel



3.5.4.2 Installing the Intel® RMM2

1. Insert the standoff into the hole labeled “TH4” on the Intel® RMM2. (Figure 49, “A”) The standoff fastens to the bottom side of the module.
2. Fasten the Intel® RMM2 to the S5000PHB server board site using the Advanced Server Management Interface (ASMI) connector (“B”) and snap the standoff into the matching hole in the server board.
3. If this is the last task you are performing, replace the riser card assembly, the processor air duct, and the top cover of the chassis. Reconnect all the external devices and plug in the power cord(s).

Figure 49. Installing the Intel® Remote Management Module 2





3.5.5 Replacing the Power Distribution Board

The power distribution board routes power from the power supply to the rest of the server system. Use the following instructions to replace the PDB.

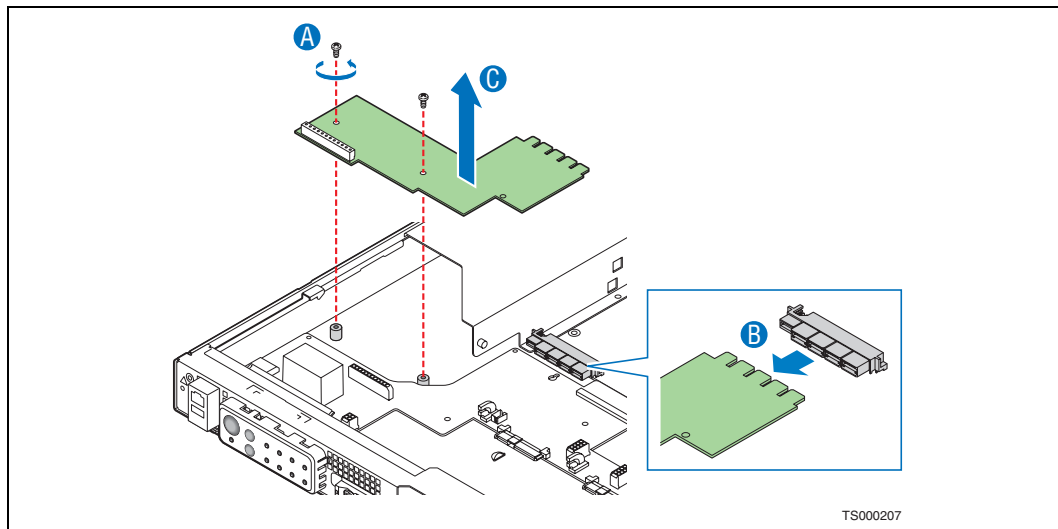
Caution: Before replacing any board in the Carrier Grade Server TIGW1U, you must first take the server out of service, turn off all peripheral devices connected to the system, turn off the system by pressing the power button, and unplug the power cord from the system or wall outlet.

When handling this board, observe safety and ESD precautions. See Appendix A, "Safety Information" for more information.

3.5.5.1 Removing the Power Distribution Board

1. Power down the server system and unplug all peripheral devices and the AC power cable.
2. Remove the chassis cover.
3. Remove the PCI fan air duct.
4. Unscrew the fastening screws. ("A" in Figure 50)
5. Disconnect the power interconnect to the SFP board from the power distribution board (PDB).
6. Gently pull the PDB away from the power supply connector on the server board ("B").
7. Lift the PDB from the chassis ("C").

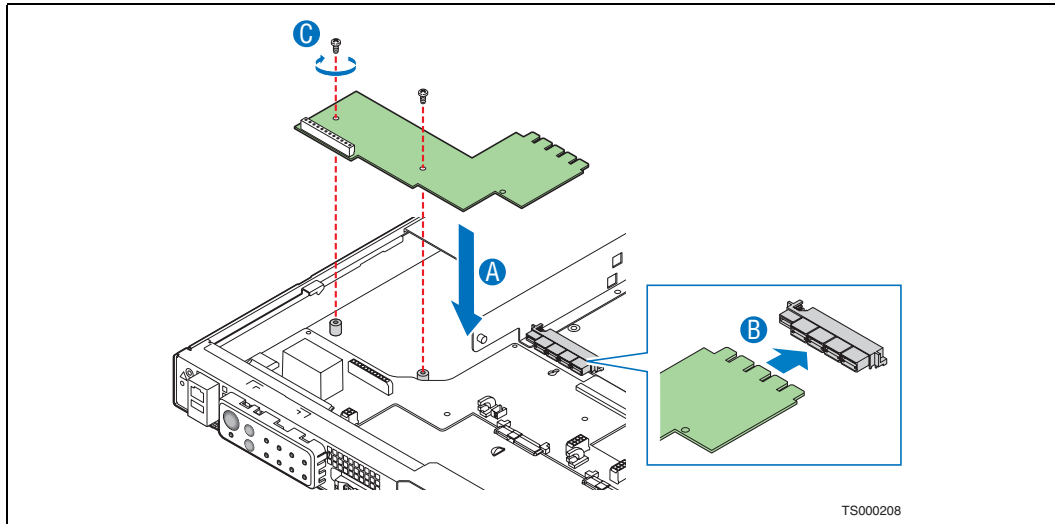
Figure 50. Removing the PDB



3.5.5.2 Installing the Power Distribution Board Back into the Chassis

1. Lower the replacement power distribution board (PDB) into place. ("A" in Figure 51)
2. Make sure that the PDB is placed over the placement pegs and gently push down. ("C")

Figure 51. Installing the PDB



3. Connect all power cables and the edge connector ("B").
4. Install the PCI fan air duct and the chassis cover.

3.5.6 Replacing the Server Board

The Carrier Grade Server TIGW1U uses the Intel® Server Board S5000PHB. To replace the server board, the following components must be removed:

All components on the server board:

- Heat sink(s)
- Processor(s)
- All DIMMs
- PCI riser assembly
- Four-fan assembly

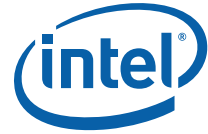
To replace the server board, use the following instructions.

Caution: Before replacing a Carrier Grade Server TIGW1U board, you must first take the server out of service, turn off all peripheral devices connected to the system, turn off the system by pressing the power button, and unplug the power cord from the system or wall outlet.

When handling this board or any of the components on it, observe safety and ESD precautions. See Appendix A, "Safety Information" for more information.

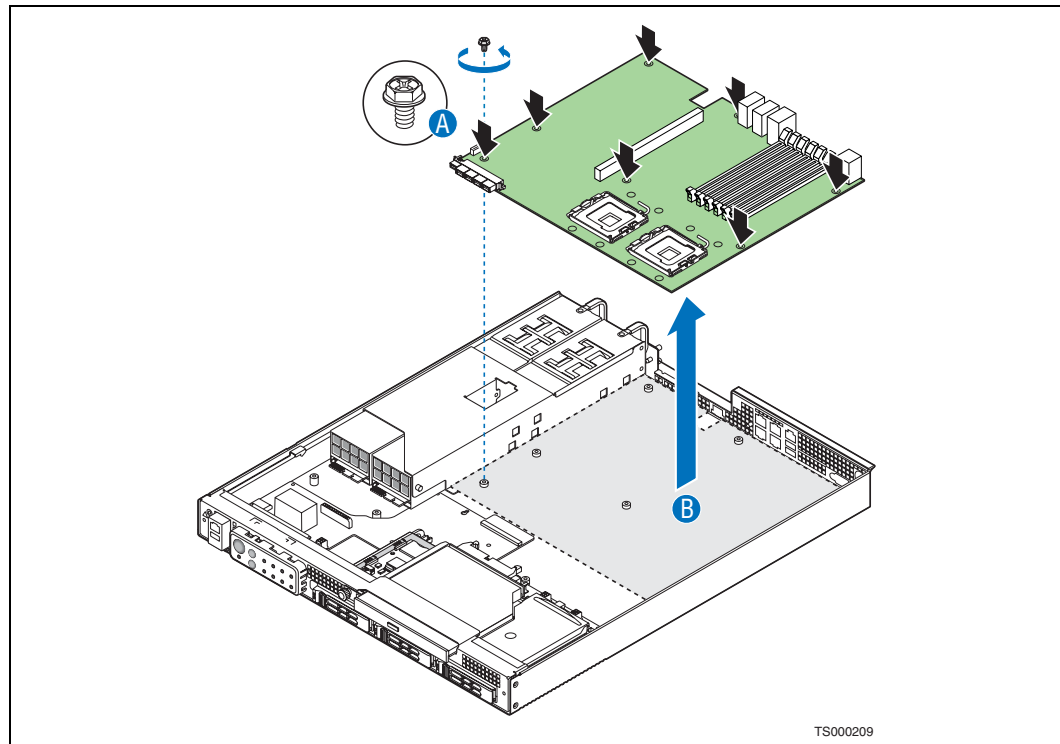
3.5.6.1 Removing the Server Board

1. Power down the server system and unplug all peripheral devices and the power cable.
2. Remove the chassis cover and processor air duct.
3. Remove the PCI riser assembly. For instructions, see Section 3.4.5.1, "Removing the PCI Riser Card Assembly" on page 40.



4. Remove all DIMMs. For instructions, see Section 3.4.3.2, “Removing DIMMs” on page 35.
5. Remove the heat sink(s) and processor(s). For instructions, see Section 3.4.4.2, “Removing a Processor” on page 36.
6. Remove the four-fan assembly, including the bracket.
7. Disconnect all cables from the server board.
8. Remove the screws that attach the server board to the chassis. (“A” in Figure 52)
9. Tilt the server board and lift it from the chassis. (“B”) Use caution in pulling it out from beneath the Serial B connector at the rear of the chassis.

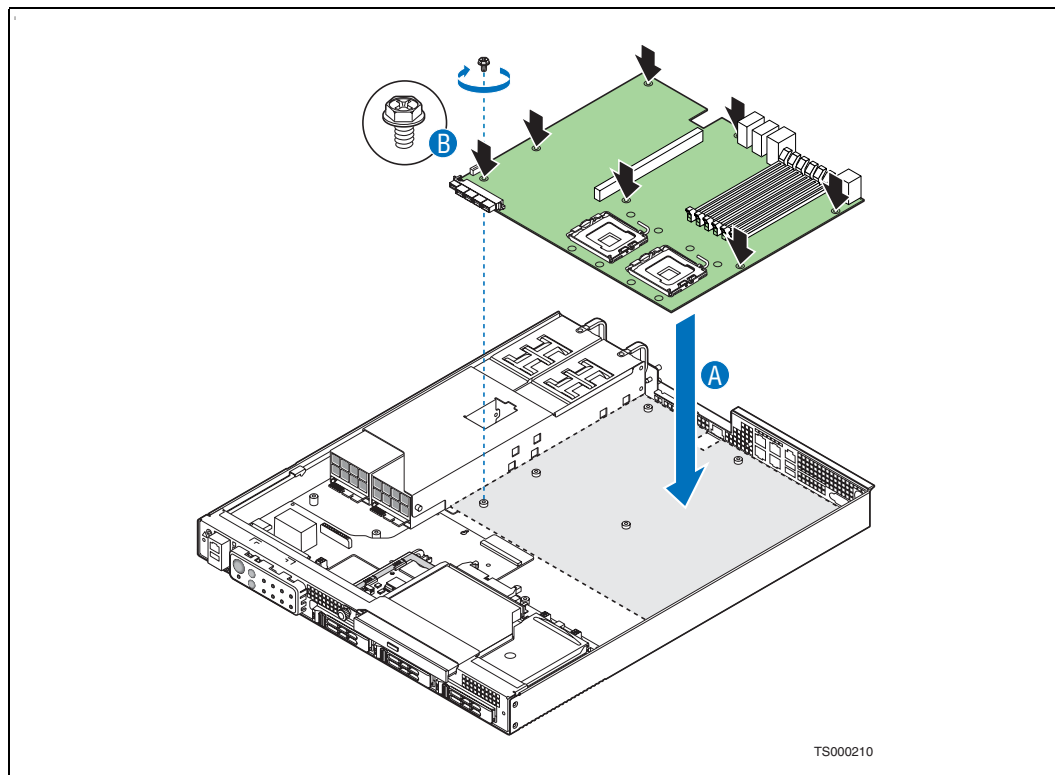
Figure 52. Removing the Server Board



3.5.6.2 Installing the Server Board Back into the Chassis

1. Set the replacement board into place (“B” in Figure 53), using caution to make sure that no cables are pinched under the board. Insert the rear edge of the board first, and line up the I/O ports at the rear of the system.
2. Make sure the standoff locations line up correctly and reinsert the seven screws removed previously. (“A”)

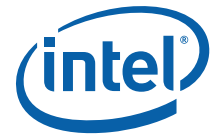
Figure 53. Installing the Server Board



3. Configure any jumpers where you do not want to use the default settings. For instructions, see Section 3.4.1, “Configuring Jumpers on the Server Board” on page 29.
4. Connect all cables to the server board.
5. Install the CPU four-fan assembly. For instructions, see Section 3.5.2.1, “Replacing the CPU Four-Fan Assembly” on page 52.
6. Install the processor(s) and heat sink(s). For instructions, see Section 3.4.4.3, “Installing a New Processor” on page 37.
7. Install all DIMMs. For instructions, see Section 3.4.3.1, “Installing DIMMs” on page 34.
8. Install the PCI riser assembly. For instructions, see Section 3.4.5.4, “Installing the Riser Card Assembly onto the Server Board” on page 43.
9. Install the processor air duct. For instructions, see Section 3.2.6, “Installing the Processor Air Duct” on page 25.
10. Install the chassis cover and all external cables and power the system back up.

3.5.7 Replacing the CMOS Battery on the Server Board

The lithium battery on the server board powers the real-time clock (RTC) for up to 10 years in the absence of power. When the battery starts to weaken, it loses voltage, and the server settings (for example, the date and time) stored in CMOS RAM (Random Access Memory) in the RTC may be wrong. Contact your Intel sales support representative or dealer for a list of approved devices.



Caution: Before replacing the battery, you must first take the server out of service, turn off all peripheral devices connected to the system, turn off the system by pressing the power button, and unplug the power cord from the system or wall outlet.

WARNING

Danger of explosion if battery is replaced incorrectly. Replace only with the same or equivalent type recommended by the equipment manufacturer. Discard used batteries according to manufacturer's instructions.

WARNING

Lithiumbatteri - Eksplosionsfare ved fejlagtig håndtering. Udsiftning må kun ske med batteri af samme fabrikat og type. Levér det brugte batteri tilbage til leverandøren.

ADVARSEL

Lithiumbatteri - Eksplosjonsfare. Ved utskifting benyttes kun batteri som anbefalt av apparatfabrikanten. Brukt batteri returneres apparatleverandøren.

WARNING

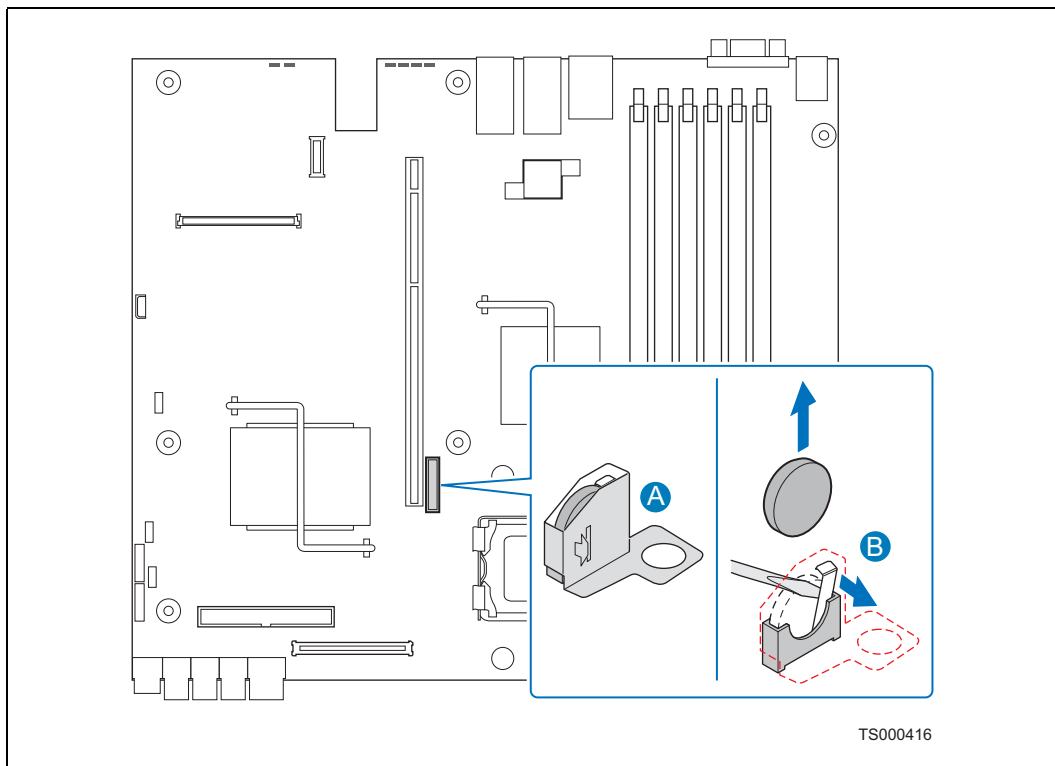
Explosionsfara vid felaktigt batteribyte. Använd samma batterityp eller en ekvivalent typ som rekommenderas av apparattillverkaren. Kassera använt batteri enligt fabrikantens instruktion.

VAROITUS

Paristo voi räjähtää, jos se on virheellisesti asennettu. Vaihda paristo ainoastaan laitevalmistajan suosittelemaan tyyppiin. Hävitä käytetty paristo valmistajan ohjeiden mukaisesti.

1. Power down the server system and unplug all peripheral devices and the power cable.
2. Remove the chassis cover.
3. Remove the processor air duct. For instructions, see Section 3.2.5, "Removing the Processor Air Duct" on page 24.
4. Locate the battery. See Figure 54.
5. Insert the tip of a small flat-bladed screwdriver, or an equivalent, under the tab in the plastic retainer. Gently push down on the screwdriver to lift the battery.
6. Remove the battery from its socket.

Figure 54. Replacing the Battery



7. Dispose of the battery according to local ordinance.
8. Being careful to observe the correct polarity, insert the new battery into the socket.
9. Re-install the processor air duct and the chassis cover.
10. Run Setup to restore the configuration settings to the RTC.

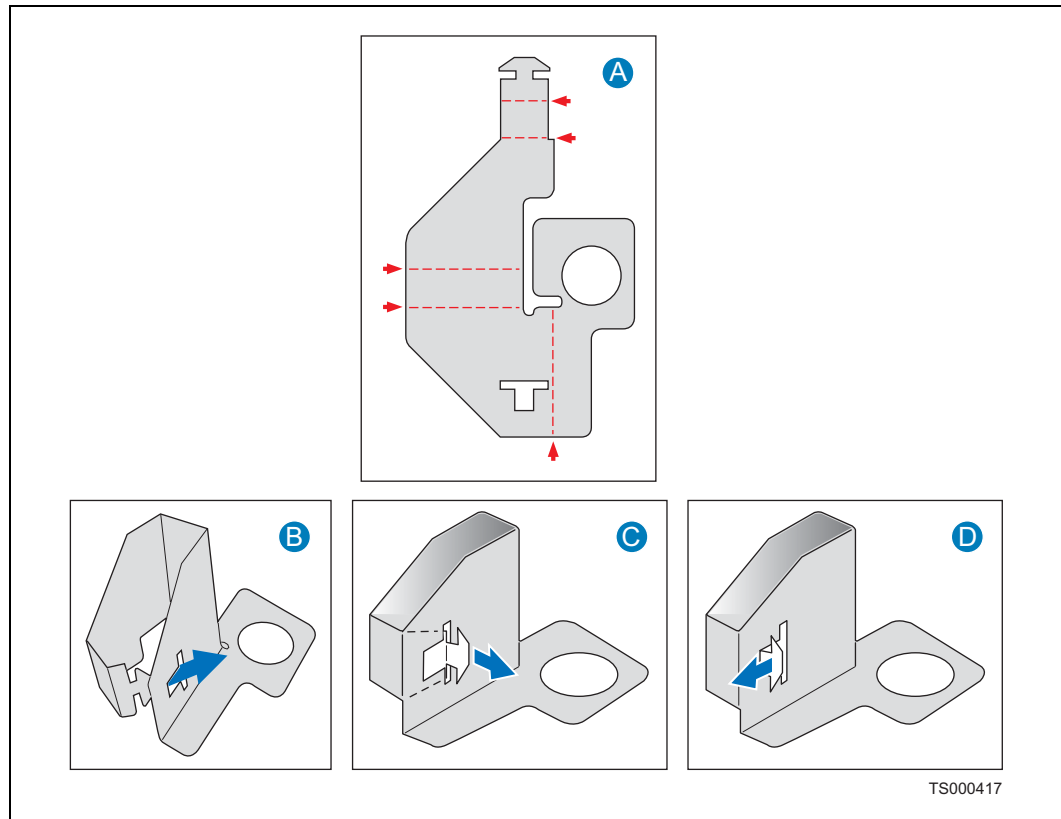


3.5.8 Installing the Battery Insulator

If you are installing the battery on a new server board or replacing it on a server board that does not have the protective insulator surrounding the battery, use the following procedure to install the insulator.

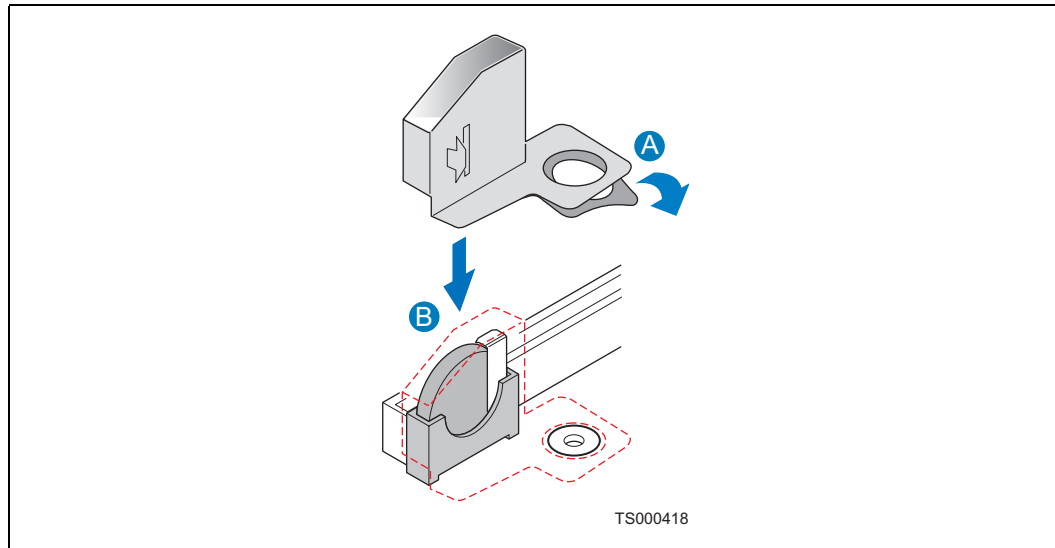
1. Fold the battery insulator along the scored bend lines as shown in Figure 55 and insert the tab in the slot to fasten the insulator.

Figure 55. Folding the Battery Insulator



2. Remove the adhesive cover from the bottom of the insulator.
Place the insulator around the battery, lining up the hole with the riser card assembly hole. See Figure 56.

Figure 56. Attaching the Battery Insulator



3.6 Installing the Server into a Rack

Installation instructions for the standard bracket kit and the optional rail kit are included with each kit. These instructions can also be found on the Resource CD and at <http://support.intel.com/support/motherboards/server/chassis/NSW1U/>

3.6.1 Connecting the Power Cord

Note: When placing your server in a rack, wait to install the power cord until after the server is in the rack.

3.6.2 Equipment Rack Precautions

Caution: **ANCHOR THE EQUIPMENT RACK:** The equipment rack must be anchored to an unmovable support to prevent it from falling over when one or more servers are extended in front of it on slide assemblies. The equipment rack must be installed according to the manufacturer's instructions. You must also consider the weight of any other device installed in the rack.

Mains power disconnect: The power cord(s) is considered the mains disconnect for the server and must be readily accessible when installed. If the individual server power cord(s) will not be readily accessible for disconnection then you are responsible for installing an AC power disconnect for the entire rack unit. This main disconnect must be readily accessible, and it must be labeled as controlling power to the entire rack, not just to the server(s). To remove all power, two power cords must be removed.

Grounding the rack installation: To avoid the potential for an electrical shock hazard, you must include a third wire safety ground conductor with the rack installation. If the server power cord is plugged into an outlet that is part of the rack, then you must provide proper grounding for the rack itself. If the server power cord is



plugged into a wall outlet, the safety ground conductor in the power cord provides proper grounding only for the server. You must provide additional, proper grounding for the rack and other devices installed in it.

Overcurrent protection: The server is designed for a line voltage source with up to 20 amperes of overcurrent protection per cord feed. If the power system for the equipment rack is installed on a branch circuit with more than 20 amperes of protection, you must provide supplemental protection for the server. The overall current rating of a server configured with two power supplies is less than 4 amperes.

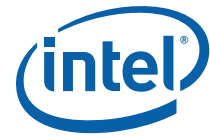
Caution:

Temperature: The operating temperature of the server, when installed in an equipment rack, must not go below 5°C (41°F) or rise above 35°C (95°F). Extreme fluctuations in temperature can cause a variety of problems in your server.

Ventilation: The equipment rack must provide sufficient airflow to the front of the server to maintain proper cooling. It must also include ventilation sufficient to exhaust a maximum of 1200 BTU per hour for a fully loaded server system using the Intel® Carrier Grade Server TIGW1U.

It is important to note that this measurement is the maximum, and a minimum or typical system could use much less. You may want to calculate the BTU/hr measurement more accurately for your configuration. An extra 500 BTU/hr over many systems would translate into a large error calculating air conditioning capacity.





4 Server Utilities

4.1 Using the BIOS Setup Utility

This section describes the BIOS Setup Utility options, which is used to change configuration defaults for the Intel® Carrier Grade Server TIGW1U. You can run BIOS Setup with or without an operating system being present. See the *Intel® Carrier Grade Server TIGW1U Technical Product Specification* for details about specific BIOS setup screens.

4.1.1 Starting Setup

You can enter and start BIOS Setup under several conditions:

- When you turn on the server, after POST completes the memory test
- When you have moved the CMOS jumper on the server board to the “Clear CMOS” position (enabled)

In the two conditions listed above, during the Power On Self Test (POST), you will see the prompt

```
Press <F2> to enter SETUP
```

In a third condition, when CMOS/NVRAM has been corrupted, you will see other prompts, but not the <F2> prompt:

```
Warning: CMOS checksum invalid
```

```
Warning: CMOS time and date not set
```

In this condition, the BIOS will load default values for CMOS and attempt to boot.

4.1.2 If You Cannot Access Setup

If you cannot access BIOS Setup, you might need to clear the CMOS memory. For instructions on clearing the CMOS, see Section 4.4, “Clearing the CMOS”.

4.1.3 Setup Menus

Each BIOS Setup menu page contains several features. Except for those features that are provided only to display automatically configured information, each feature is associated with a value field that contains user-selectable parameters. These parameters can be changed if the user has adequate security rights. If a value cannot be changed for any reason, the feature's value field is inaccessible.

Table 7 describes the keyboard commands you can use in the BIOS Setup menus.



Table 7. Keyboard Commands

Key	Description
<F1>	Help - Pressing F1 on any menu invokes the general Help window.
← →	The left and right arrow keys are used to move between the major menu pages. The keys have no effect if a submenu or pick list is displayed.
↑	Select Item up - The up arrow is used to select the previous value in a menu item's option list, or a value field pick list. Pressing the Enter key activates the selected item.
↓	Select Item down - The down arrow is used to select the next value in a menu item's option list, or a value field pick list. Pressing the Enter key activates the selected item.
F5/-	Change Value - The minus key or the F5 function key is used to change the value of the current item to the previous value. This key scrolls through the values in the associated pick list without displaying the full list.
F6/+	Change Value - The plus key or the F6 function key is used to change the value of the current menu item to the next value. This key scrolls through the values in the associated pick list without displaying the full list. On 106-key Japanese keyboards, the plus key has a different scan code than the plus key on the other keyboard, but it has the same effect.
<Enter>	Execute Command - The Enter key is used to activate submenus when the selected feature is a submenu, or to display a pick list if a selected feature has a value field, or to select a sub-field for multi-valued features like time and date. If a pick list is displayed, the Enter key will undo the pick list, and allow another selection in the parent menu.
<Esc>	Exit - The ESC key provides a mechanism for backing out of any field. This key will undo the pressing of the Enter key. When the ESC key is pressed while editing any field or selecting features of a menu, the parent menu is re-entered. When the ESC key is pressed in any submenu, the parent menu is re-entered. When the ESC key is pressed in any major menu, the exit confirmation window is displayed and the user is asked whether changes can be discarded.
<F9>	Setup Defaults - Pressing F9 causes the following to appear: Setup Confirmation Load default configuration now? [Yes] [No] If "Yes" is selected and the Enter key is pressed, all Setup fields are set to their default values. If "No" is selected and the Enter key is pressed, or if the ESC key is pressed, the user is returned to where they were before F9 was pressed without affecting any existing field values.
<F10>	Save and Exit - Pressing F10 causes the following message to appear: Setup Confirmation Save Configuration changes and exit now? [Yes] [No] If "Yes" is selected and the Enter key is pressed, all changes are saved and Setup is exited. If "No" is selected and the Enter key is pressed, or the ESC key is pressed, the user is returned to where they were before F10 was pressed without affecting any existing values.

4.1.4 CMOS Clear and Password Reset Procedure

The CMOS Clear and Password Reset recovery features are designed to achieve the desired operation with minimal system down time. The procedure for activating these two features has changed from what was used with previous generation Intel server boards. The new usage model is:

1. Power down the system and turn off the power.
2. Open the server chassis (remove the top cover). For instructions, see Section 3.2.1, "Removing the Chassis Cover"
3. Move the jumper from the default operating position (Pins 1-2) to the Reset/Clear position (Pins 2-3). For the location of this jumper, see Figure 7.
4. Wait 5 seconds.
5. Move the jumper back to the default position (Pins 1-2).
6. Close the server.



7. Reconnect the power and restart the system.

The password and/or CMOS is now cleared and can be reset by going into the BIOS setup.

4.1.5 BMC Force Update Procedure

When performing a standard BMC firmware update procedure, the update utility places the BMC into an update mode to allow the firmware to load safely onto the flash device. In the unlikely event that the BMC firmware update process fails because the BMC is not in the proper update state, the server board provides a BMC Force Update jumper that can force the BMC into the proper update state. Use the following procedure if the standard BMC firmware update process fails.

Once the firmware update process completes successfully, the firmware update utility may generate an error stating that the BMC is still in update mode. Use the following procedure to get out of Update mode.

1. Power down and remove AC power.
2. Open the server chassis (remove the top cover).
3. Remove the jumper from J1E3.
4. Close the server.
5. Reconnect the AC power and restart the system.

Now perform the standard BMC firmware update procedure as documented in the README.TXT file included in the BMC Firmware Update package.

Note: Normal BMC functionality is disabled when the Force BMC Update jumper is populated. The server should never be run with the BMC Force Update jumper populated and should only be used when the standard firmware update process fails. This header should remain unpopulated by default when the server is running normally.

4.2 Upgrading the BIOS

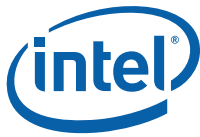
The upgrade utility allows you to upgrade the BIOS in flash memory. The code and data in the upgrade file include the following:

- On-board system BIOS, including the recovery code, BIOS Setup Utility, and strings.
- On-board video BIOS, SCSI BIOS, and other option ROMs for devices embedded on the server board.
- OEM binary area.
- Microcode.
- A means to change the BIOS language.

4.2.1 Preparing for the Upgrade

The steps below explain how to prepare to upgrade the BIOS, including how to record the current BIOS settings and how to obtain the upgrade utility.

Note: In the unlikely event that a BIOS error occurs during the BIOS update process, a recovery process may need to be followed to return the system to service. See Section 1.4, "Additional Information and Software" on page 10 for additional information.



4.2.1.1 Recording the Current BIOS Settings

1. Boot the computer and press <F2> when you see the message:

Press <F2> Key if you want to run SETUP
2. Write down the current settings in the BIOS Setup program.

Note: Do not skip step 2. You will need these settings to configure your computer at the end of the procedure.

4.2.1.2 Obtaining the Upgrade

Download the BIOS image file to a temporary folder on your hard drive. See Section 1.4, “Additional Information and Software” on page 10 for additional information.

Note: Review the instructions and release notes that are provided in the readme file distributed with the BIOS image file before attempting a BIOS upgrade. The release notes contain critical information regarding jumper settings, specific fixes, or other information to complete the upgrade.

4.2.2 Updating the BIOS

Follow the instructions in the readme file that came with the BIOS upgrade. When the update completes, remove the bootable media from which you performed the upgrade.

Note: Do not power down the system during the BIOS update process! The system will reset automatically when the BIOS update process is completed.

Note: You may encounter a CMOS Checksum error or other problem after reboot. If this happens, shut down the system and boot it again. CMOS checksum errors require that you enter Setup, check your settings, save your settings, and exit Setup.

4.3 Clearing the Password

If the user or administrator password(s) is lost or forgotten, moving the password clear jumper on the server board (item W in Figure 7, “Intel® Server Board S5000PHB Connector and Component Locations” on page 17) into the “clear” position clears both passwords. The password clear jumper must be restored to its original position before a new password(s) can be set.

1. Power down the system and disconnect the power.
2. Open the server chassis. See Section 3.2.1, “Removing the Chassis Cover” for instructions.
3. Move the jumper from the normal operation position, Password Clear Protect, at pins 1 and 2 to the Password Clear Erase position, covering pins 2 and 3.
4. Reconnect the power, power up the system.
5. Power down the system and disconnect the AC power.
6. Return the Password Clear jumper to the Password Clear Protect position, covering pins 1 and 2.
7. Close the server chassis. See Section 3.2.2, “Installing the Chassis Cover” for instructions.
8. Reconnect the power and power up the server.

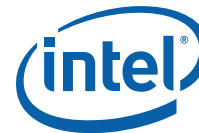


4.4 Clearing the CMOS

If you cannot access the BIOS setup screens, the CMOS Clear jumper (item Z in Figure 7, "Intel® Server Board S5000PHB Connector and Component Locations" on page 17) will need to be used to reset the configuration RAM.

1. Power down the system and disconnect the AC power.
2. Open the server. See Section 3.2.1, "Removing the Chassis Cover" for instructions.
3. Move the jumper from the normal operation position, CMOS Clear by BMC, at pins 1 and 2 to the CMOS Clear Force Erase position, covering pins 2 and 3.
 1. Reconnect the power and start up the system.
 2. When the system begins beeping, power it down and disconnect the AC power.
 3. Return the CMOS Clear jumper to the CMOS Clear by BMC location, covering pins 1 and 2.
4. Close the server chassis. See Section 3.2.2, "Installing the Chassis Cover" for instructions.
5. Reconnect the power and power up the system.





5 Troubleshooting

This chapter helps you identify and solve problems that might occur while you are using the Intel® Carrier Grade Server TIGW1U.

For any issue, first ensure you are using the latest firmware and files. Firmware upgrades include updates for BIOS and the server board management controller (BMC). Go to <http://support.intel.com/support/telecom/computeboards/tigw1u/> for information about the latest updates. In addition to the server firmware and files, also update any drivers used for components you have installed in your system, such as video drivers, network drivers, and SCSI drivers.

Intel provides a package called the “Platform Confidence Test” that may help with your diagnostics. Go to <http://support.intel.com/support/telecom/computeboards/tigw1u/> for a link to this software.

If you are unable to resolve your server problems on your own, see Appendix C, “Getting Help” for assistance.

5.1 Resetting the System

Before going through in-depth troubleshooting, first attempt to reset your system using one of the methods below.

To do this:	Press:
Soft boot reset to clear the system memory and reload the operating system.	<Ctrl+Alt+Del>
Clear system memory, restart POST, and reload the operating system.	Reset button
Cold boot reset. Turn the system power off and then on. This clears system memory, restarts POST, reloads the operating system, and halts power to all peripherals.	Power off/on

5.2 Problems Following Initial System Installation

Problems that occur at initial system startup are usually caused by an incorrect installation or configuration. Hardware failure is a less frequent cause. If the problem you are experiencing is with a specific software application, see Section 5.4.11, “Problems with Newly Installed Application Software” on page 80.

5.2.1 First Steps Checklist

- Is power available at the wall outlet?
- Are the power supplies plugged in? Check the power cable on the back of the server and at the power source.
- Is the system power cord properly connected to the system and plugged into a NEMA (National Electrical Manufacturing Association) 5-15R outlet for 100-120V or a NEMA 6-15R outlet for 200-240V?
- Are all cables correctly connected and secured?



- Are the processors fully seated in their sockets on the server board?
- Are all standoffs in the proper location and not touching any components, causing a potential short?
- Are all add-in PCI boards fully seated in their slots on the server board?
- Are all jumper settings, including the processor jumper, on the server board correct?
- Are all jumper and switch settings on add-in boards and peripheral devices correct? To check these settings, refer to the manufacturer's documentation that comes with them. If applicable, ensure that there are no conflicts—for example, two add-in boards sharing the same interrupt.
- Are all peripheral devices installed correctly?
- If the system has a hard disk drive, is it properly formatted or configured?
- Are all device drivers properly installed?
- Are the configuration settings made in Setup correct?
- Is the operating system properly loaded? Refer to the operating system documentation.
- Did you press the system power on/off switch on the front panel to turn the server on (power on light should be lit)?
- Are all integrated components from the tested components lists? Check the tested memory list and the supported hardware and operating system list. Go to <http://support.intel.com/support/telecom/computeboards/tigw1u/> for links to the tested component lists.

5.3 Hardware Diagnostic Testing

This section provides a more detailed approach to identifying a hardware problem and locating its source.

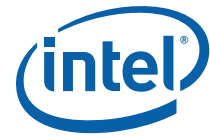
Caution: **Turn off devices before disconnecting cables.** Before disconnecting any peripheral cables from the system, turn off the system and any external peripheral devices. Failure to do so can cause permanent damage to the system and/or the peripheral devices.

1. Turn off the system and all external peripheral devices. Disconnect each of devices from the system, except for the keyboard and the video monitor.
2. Make sure the system power cord is plugged into a properly grounded outlet.
3. Make sure your video display monitor and keyboard are correctly connected to the system. Turn on the video monitor. Set its brightness and contrast controls to at least two thirds of their maximum ranges (see the documentation supplied with your video display monitor).
4. Turn on the system. If the power LED does not light, see Section 5.4.1, "Power Light does not Light".

5.3.1 Verifying Proper Operation of Key System Lights

As POST determines the system configuration, it tests for the presence of each mass storage device installed in the system. As each device is checked, its activity light should turn on briefly. Check for the following:

- If system LEDs are illuminated, see Section 5.5, "LED Information" for a description of the LED lights and steps that need to be taken to correct the problem.



5.3.2 Confirming Loading of the Operating System

Once the system boots up, the operating system prompt appears on the screen. The prompt varies according to the operating system. If the operating system prompt does not appear, see Section 5.4.2, “No Characters Appear on Screen”.

5.4 Specific Problems and Corrective Actions

This section provides possible solutions for specific problems:

Try the solutions below in the order given. If you cannot correct the problem, contact your service representative or authorized dealer for help. See Appendix C, “Getting Help” for contact details.

5.4.1 Power Light does not Light

Check the following:

- Did you press the power-on button?
- Is the system operating normally? If so, the power LED might be defective or the cable from the front panel to the server board might be loose.
- Have you securely plugged the server power cord into the power supply?
- Is the power supply correctly set to 110 V or 235 V, depending on your power output?
- For AC, will other items plugged into the same power outlet function correctly?
- Remove all add-in cards and see if the system boots. If successful, re-insert the cards one at a time with a reboot between each addition.
- Make sure the memory DIMMs comply with the system requirements.
- Make sure the memory DIMMs have been populated according to the system requirements.
- Remove the memory DIMMs and re-seat them.
- Make sure the processor jumper is correctly configured.
- Make sure the processor complies with the system requirements.
- Remove the processor and re-seat it.

5.4.2 No Characters Appear on Screen

Check the following:

- Is the keyboard functioning? Test it by turning the “Num Lock” function on and off to make sure the Num Lock light is functioning.
- Is the video monitor plugged in and turned on? If you are using a switch box, is it switched to the correct system?
- Are the brightness and contrast controls on the video monitor properly adjusted?
- Is the video monitor signal cable properly installed?
- Does this video monitor work correctly if plugged into a different system?
- Is the onboard video controller enabled in the BIOS?
- Remove all add-in cards and see if the video returns. If successful, re-insert the cards one at a time with a reboot between each addition.
- Make sure the memory DIMMs comply with the system requirements.



- Make sure the memory DIMMs have been populated according to the system requirements.
- Remove the memory DIMMs and re-seat them.
- Make sure the processor complies with the system requirements.
- Remove the processor and re-seat it.

If you are using an add-in video controller board, do the following:

1. Verify that the video works using the onboard video controller.
2. Verify that the video controller board is fully seated in the server board connector.
3. Reboot the system for changes to take effect.
4. If there are still no characters on the screen after you reboot the system and POST emits a beep code, write down the beep code you hear. This information is useful for your service representative.
5. If you do not receive a beep code and characters do not appear, the video display monitor or video controller may have failed. Contact your service representative or authorized dealer for help.

5.4.3 Characters are Distorted or Incorrect

Check the following:

- Are the brightness and contrast controls properly adjusted on the video monitor? See the manufacturer's documentation.
- Are the video monitor's signal and power cables properly installed?
- Does this video monitor work correctly if plugged into a different system?

5.4.4 System Cooling Fans do not Rotate Properly

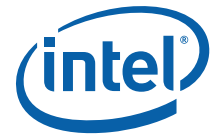
If the system cooling fans are not operating properly, it is an indication of possible system component failure.

Check the following:

- Is the power-on light lit? If not, see Section 5.4.1, "Power Light does not Light".
- Are any other front panel LEDs lit?
- Have any of the fan motors stopped? Use the server management subsystem to check the fan status.
- Have your fans speeded up in response to an overheating situation?
- Have your fans speeded up in response to a fan that has failed?
- Are the fan power connectors properly connected to the server board?
- Is the cable from the front panel board connected to the both the front panel board and to the server board?
- Are the power supply cables properly connected to the server board?
- Are there any shorted wires caused by pinched-cables or have power connector plugs been forced into power connector sockets the wrong way?

5.4.5 Cannot Connect to a Server

- Make sure the network cable is securely attached to the correct connector at the system back panel.
- Try a different network cable.



- ❑ Make sure you are using the correct and the current drivers. Go to <http://support.intel.com/support/telecom/computeboards/nsw1u/> for a link to the drivers.
- ❑ Make sure the driver is loaded and the protocols are bound.
- ❑ Make sure the hub port is configured for the same duplex mode as the network controller.
- ❑ Make sure the correct networking software is installed.
- ❑ If you are directly connecting two servers (without a hub), you will need a crossover cable.
- ❑ Check the network controller LEDs next to the NIC connectors.

5.4.6 Diagnostics Pass but the Connection Fails

- ❑ Make sure the network cable is securely attached.
- ❑ Make sure you specify the correct frame type in your NET.CFG file.

5.4.7 The Server Hangs When the Drivers are Loaded

- ❑ Certain drivers may require interrupts that are not shared with other PCI drivers. For these drivers, it may be necessary to alter settings so that interrupts are not shared. See the documentation that came with your PCI card(s) for information on changing interrupts.

5.4.8 The Controller Stopped Working When an Add-in Adapter was Installed

- ❑ Make sure the cable is connected to the port from the onboard network controller.
- ❑ Make sure your BIOS is current. Go to <http://support.intel.com/support/telecom/computeboards/tigw1u/> for a link to the current version.
- ❑ Make sure the other adapter supports shared interrupts. Make sure your operating system supports shared interrupts.
- ❑ Try reseating the add-in adapter.

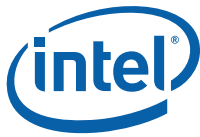
5.4.9 The Add-in Adapter Stopped Working Without Apparent Cause

- ❑ Try reseating the adapter first; then try a different slot if necessary.
- ❑ The network driver files may be corrupt or deleted. Delete and then reinstall the drivers.
- ❑ Run the diagnostics.

5.4.10 System Boots When Installing a PCI Card

System Server Management features require full-time “standby” power. This means some parts of the system have power going to them whenever the power cord is plugged in, even if you have turned the system power off with the power button on the front panel. If you install a PCI card with the power cord plugged in, a signal may be sent to command the system to boot. Before installing a PCI card, you should always:

1. Turn off the server power by using the power button on the front of the system.
2. Unplug the power cord from the server.



5.4.11 Problems with Newly Installed Application Software

Problems that occur when you run new application software are usually related to the software, not the server hardware. Faulty equipment is unlikely, especially if other software runs correctly.

Check the following:

- Make sure the system meets the minimum hardware requirements for the software. See the software documentation.
- Make sure the software is properly installed and configured for the system. See the software documentation.
- Use only an authorized copy. Unauthorized copies often do not work.
- Make sure the correct device drivers installed.

If the problems persist, contact the software vendor's customer service representative.

5.4.12 Problems with Application Software that Ran Correctly Earlier

Problems that occur after the system hardware and software have been running correctly sometimes indicate equipment failure. However, they can also be caused by file corruption or changes to the software configuration.

Check the following:

- Uninstall and reinstall the software. Make sure all necessary files are installed.
- If the problems are intermittent, there may be a loose cable, dirt in the keyboard (if keyboard input is incorrect), a marginal power supply, or other random component failures.
- If you suspect that a transient voltage spike, power outage, or brownout might have occurred, reload the software and try running it again. Symptoms of voltage spikes include a flickering video display, unexpected system reboots, and the system not responding to user commands.

Note: For AC power, if you are getting random errors in your data files, they may be getting corrupted by voltage spikes on your power line. If you are experiencing any of the above symptoms that might indicate voltage spikes on the power line, you may want to install a surge suppressor between the power outlet and the system power cord.

5.4.13 Devices are not Recognized under Device Manager (Windows* Operating System)

The Windows* operating systems do not include all of the drivers for the Intel® chipsets, onboard NICs, and other components. See Go to <http://support.intel.com/support/telecom/computeboards/nsw1u/> for a link to the current drivers and chipset files.

5.4.14 Hard Drive(s) are not Recognized

Check the following:

- Make sure the drive is not disabled in BIOS Setup.
- Make sure the drive is connected correctly and that it is plugged into the power supply.
- Make sure the drive is compatible. Go to <http://support.intel.com/support/telecom/computeboards/nsw1u/> for a link to the list tested drives.



- ❑ Make sure you have not exceeded the power budget for the server. Go to <http://support.intel.com/support/telecom/computeboards/nsw1u/> for a link to software to check your power budget.

5.5 LED Information

The Intel® Server Board S5000PHB includes LEDs that can aid in troubleshooting your system. Table 8 defines these LEDs with a description of their use.

Table 8. LED Definitions

LED Name	Function	Location	Color	Notes
ID	Aid in server identification from the back panel	Control panel and board rear left corner	Blue	Press ID LED button or user Server Management software to turn on the LED.
System fault	Visible fault warning	Control panel and board rear left corner	Green or Amber	Green = No Fault Green blinking = degraded Amber = critical error or non-recoverable Amber blinking = non-critical error
ATA drive activity	Control panel	Control panel	Green	Blinking = Activity. No action required.
Memory fault 1–6	Identify failing memory module	DIMM end rear of board	Amber	On = Fault
Diagnostic LEDs. 1–4 (LSB, bit1, bit2, MSB)	Displays port 80 POST codes	Center back edge of board	Each LED can be Off, Green, Amber, Red	See the POST code table
CPU 1 & 2 Fan Fault	Identify fan failure	Front center board	Amber	On = Fault
CPU 1 & 2 Fault	Identify processor failure	1" behind processor socket	Amber	On = Fault
5v Standby	Identify 5v standby power on state	Front left board	Amber	On = 5v standby power on
Power LED	Identify the power state of the system	Control Panel	Green	Off = Power is off (off or S5) On = Power on or S0) Slow Blink = Low power state (S1 – S3)

5.6 BIOS Error Messages

When a recoverable error occurs during the POST, the BIOS displays an error message describing the problem. See Table 9.

Table 9. BIOS Error Messages (Sheet 1 of 2)

Error Message	Explanation
GA20 Error	An error occurred with Gate A20 when switching to protected mode during the memory test.
Pri Master HDD Error Pri Slave HDD Error Sec Master HDD Error Sec Slave HDD Error	Could not read sector from corresponding drive.
Pri Master Drive - ATAPI Incompatible Pri Slave Drive - ATAPI Incompatible Sec Master Drive - ATAPI Incompatible Sec Slave Drive - ATAPI Incompatible	Corresponding drive is not an ATAPI (Advanced Technology Attachment Packet Interface) device. Run Setup to make sure device is selected correctly.



Table 9. BIOS Error Messages (Sheet 2 of 2)

Error Message	Explanation
A: Drive Error	No response from diskette drive.
CMOS Battery Low	The battery may be losing power. Replace the battery soon.
CMOS Display Type Wrong	The display type is different from what has been stored in CMOS. Check Setup to make sure type is correct.
CMOS Checksum Bad	The CMOS checksum is incorrect. CMOS memory may have been corrupted. Run Setup to reset values.
CMOS Settings Wrong	CMOS values are not the same as the last boot. Either these values have been corrupted or the battery has failed.
CMOS Date/Time Not Set	The time and/or date values stored in CMOS are invalid. Run Setup to set correct values.
DMA Error	Error during read/write test of DMA (Direct Memory Access) controller.
FDC Failure	Error occurred trying to access diskette drive controller.
HDC Failure	Error occurred trying to access hard disk controller.
Checking NVRAM.....	NVRAM (Non-Volatile Random Access Memory) is being checked to see if it is valid.
Update OK!	NVRAM was invalid and has been updated.
Updated Failed	NVRAM was invalid but was unable to be updated.
Keyboard Error	Error in the keyboard connection. Make sure keyboard is connected properly.
KB/Interface Error	Keyboard interface test failed.
Memory Size Decreased	Memory size has decreased since the last boot. If no memory was removed, then memory may be bad.
Memory Size Increased	Memory size has increased since the last boot. If no memory was added, there may be a problem with the system.
Memory Size Changed	Memory size has changed since the last boot. If no memory was added or removed, then memory may be bad.
No Boot Device Available	System did not find a device to boot.
Off Board Parity Error	A parity error occurred on an off-board card. This error is followed by an address.
On Board Parity Error	A parity error occurred in onboard memory. This error is followed by an address.
Parity Error	A parity error occurred in onboard memory at an unknown address.
NVRAM / CMOS / PASSWORD cleared by Jumper	NVRAM, CMOS, and passwords have been cleared. The system should be powered down and the jumper removed.
<CTRL_N> Pressed	CMOS is ignored and NVRAM is cleared. User must enter Setup.

5.6.1 BIOS POST Beep Codes

Table 10 lists the POST error beep codes. Prior to system video initialization, the BIOS uses these beep codes to inform users of error conditions. Please note that not all error conditions are supported by BIOS beep codes.

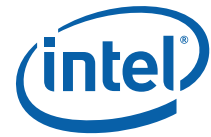


Table 10. POST Error Beep Codes

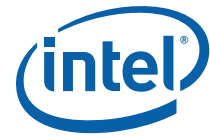
Number of Beeps	Reason for the beeps and action to take
1, 2, or 3	Memory error. Reseat the memory or replace the DIMMs with known good modules.
4 – 7 or 9 – 11	Fatal error indicating a possible serious system problem. Remove all add-in cards and re-start the system. If the error still occurs, contact your system manufacturer. If the beep codes are not generated after the add-in cards are removed, insert the cards one at a time, booting the system between each card addition, until the beeps again occur to reveal the malfunctioning card.
8	Replace or reseat the system video add-in card. If on-board video is being used, the server board may be faulty.

In addition to the beep codes above, additional beep codes are provided if an Intel® Remote Management Module (Intel® RMM) is installed. The Intel® RMM provides the following additional beep codes.

Table 11. Error Beep Codes Provided by an Intel® Remote Management Module 2

Beep Code	Reason for the beeps and action to take
1	Control panel CMOS clear has been initiated.
1-5-1-1	Processor failure. Reseat or replace the failed processor.
1-5-2-1	No processor is installed or the CPU 1 socket is empty. Reseat or replace the failed processor.
1-5-2-3	Processor configuration error or CPU 1 socket is empty. Reseat or replace the failed processor. In a two-processor system, make sure the processors are identical.
1-5-2-4	Front-side bus select configuration error.
1-5-4-2	DC power unexpectedly lost.
1-5-4-3	Chipset control failure.
1-5-4-4	Power control failure.





6 Warranty

6.1 Limited Warranty for Intel® Chassis Subassembly Products

Intel Corporation warrants that the Products (defined herein as the Intel® chassis subassembly and all of its various components and software delivered with or as part of the Products) to be delivered hereunder, if properly used and installed, will be free from defects in material and workmanship and will substantially conform to Intel's publicly available specifications for a period of three (3) years after the date the Product was purchased from an Intel authorized distributor. Software of any kind delivered with or as part of products is expressly provided "as is" unless specifically provided for otherwise in any software license accompanying the software.

If any Product furnished by Intel which is the subject of this Limited Warranty fails during the warranty period for reasons covered by this Limited Warranty, Intel, at its option, will:

- REPAIR the Product by means of hardware and/or software; OR
- REPLACE the Product with another Product; OR
- REFUND the then-current value of the Product if Intel is unable to repair or replace the Product.

If such Product is defective, transportation charges for the return of Product to buyer within the USA will be paid by Intel. For all other locations, the warranty excludes all costs of shipping, customs clearance, and other related charges. Intel will have a reasonable time to make repairs or to replace Product or to refund the then-current value of the Product.

In no event will Intel be liable for any other costs associated with the replacement or repair of Product, including labor, installation or other costs incurred by buyer and in particular, any costs relating to the removal or replacement of any product soldered or otherwise permanently affixed to any printed circuit board.

This Limited Warranty, and any implied warranties that may exist under state law, apply only to the original purchaser of the Product.

6.2 Extent of Limited Warranty

Intel does not warrant that Products to be delivered hereunder, whether delivered stand-alone or integrated with other Products, including without limitation semiconductor components, will be free from design defects or errors known as "errata". Current characterized errata are available upon request.

This Limited Warranty does not cover damages due to external causes, including accident, problems with electrical power, usage not in accordance with product instructions, misuse, neglect, alteration, repair, improper installation, or improper testing.



6.3 Warranty Limitations and Exclusions

These warranties replace all other warranties, expressed or implied, including but not limited to, the implied warranties of merchantability and fitness for a particular purpose. Intel makes no expressed warranties beyond those stated here. Intel disclaims all other warranties, expressed or implied including, without limitation, implied warranties of merchantability and fitness for a particular purpose. Some jurisdictions do not allow the exclusion of implied warranties, so this limitation may not apply.

All expressed and implied warranties are limited in duration to the limited warranty period. No warranties apply after that period. Some jurisdictions do not allow limitations on how long an implied warranty lasts, so this limitation may not apply to you.

6.3.1 Limitations of Liability

Intel's responsibility under this, or any other warranty, implied or expressed, is limited to repair, replacement, or refund, as set forth above. These remedies are the sole and exclusive remedies for any breach of warranty. Intel is not responsible for direct, special, incidental, or consequential damages resulting from any breach of warranty under another legal theory including, but not limited to, lost profits, downtime, goodwill, damage to or replacement of equipment and property, and any costs of recovering, reprogramming, or reproducing any program or data stored in or used with a system containing this product. Some jurisdictions do not allow the exclusion or limitation of incidental or consequential damages, so the above limitations or exclusions may not apply to you.

This limited warranty gives you specific legal rights, and you may also have other rights that vary from jurisdiction to jurisdiction.

Any and all disputes arising under or related to this Limited Warranty shall be adjudicated in the following forums and governed by the following laws: for the United States of America, Canada, North America, and South America, the forum shall be Santa Clara, California, USA, and the applicable law shall be that of the State of California, USA; for the Asia Pacific region, the forum shall be Singapore and the applicable law shall be that of Singapore; for Europe and the rest of the world, the forum shall be London and the applicable law shall be that of the United Kingdom.

In the event of any conflict between the English language version and any other translated version(s) of this Limited Warranty, the English language version shall control.

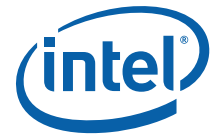
6.4 How to Obtain Warranty Service

To obtain warranty service for this Product, you may contact Intel or your authorized distributor.

North America and Latin America: To obtain warranty repair for the product, please go to the following Web site to obtain instructions:
<http://support.intel.com/support/motherboards/draform.htm>

Europe and Asia: Contact your original authorized distributor for warranty service.

Any replacement Product is warranted under this written warranty and is subject to the same limitations and exclusions for the remainder of the original warranty period.



6.4.1 Telephone Support

If you cannot find the information you need on the Intel web site (<http://www.intel.com/>), call your local distributor or an Intel Customer Support representative.

Country	Customer Support Telephone Number	Hours (Monday-Friday)	Billing
United States and Canada	1-800-404-2284	7:00–17:00 PST	Credit card calls, \$25.00/incident.
Europe			
UK	0870 6072439	UK time: 8:00–17:00 (M, Th, F) 8:00–16:00 (Tu–W)	Credit card calls, US\$25.00/incident. Levied in local currency at the applicable credit card exchange rate plus applicable VAT.
France	01 41 918529		
Germany	069 9509 6099		
Italy	02 696 33276		
Spain	91 377 8166		
Finland	9 693 79297		
Denmark	38 487077		
Norway	23 1620 50		
Sweden	08 445 1251		
Holland	020 487 4562		
Asia-Pacific			
Australia	+1-800-649-931	Singapore local time Oct–April: 6:00–16:00 April–Oct: 5:00–16:00	
Hong Kong	+852-2-844-4456		
Korea	+822-767-2595		
Philippines	1800-1-651-0117		
PRC	(800)8201100		
Singapore	(65)2131311		
Taiwan	2 27189915		
Malaysia	1800-801390		
New Zealand	0800-444365		
Indonesia	803-65-7249		
Thailand	800-6310003		
Vietnam	IDD call +63(2)6368416		
India	(0006517) 830-3634 Manual toll free. From India, you need an IDD-equipped phone.		
Pakistan	IDD call +63(2)6368415		

6.4.2 Returning a Defective Product

Before returning any product, call your authorized dealer/distribution authority.





Appendix A: Safety Information

Warning: Although you may be using this guide or another resource as a reference, before working with your server product pay close attention to these safety instructions. You must adhere to the assembly instructions in this guide to ensure and maintain compliance with existing product certifications and approvals. Use only the described, regulated components specified in this guide. Use of other products / components will void the UL listing and other regulatory approvals of the product and will most likely result in noncompliance with product regulations in the region(s) in which the product is sold.

A.1 Emissions Disclaimer

To ensure EMC (Electromagnetic Compatibility) compliance with your local regional rules and regulations, the final configuration of your end system product may require additional EMC compliance testing. For more information, please contact your local Intel Representative.

See Appendix B, "Regulatory and Certification Information" for product Safety and EMC regulatory compliance information. This is an FCC (Federal Communications Commission) Class A device.

A.2 Intended Uses

This product was evaluated as Information Technology Equipment (ITE), which may be installed in Central Offices, Telecommunication Centers, Network Telecommunication Facilities, offices, schools, computer rooms, and similar commercial type locations where The National Electric Code (NEC) applies. The suitability of this product for other product categories and environments (medical, industrial, telecommunications, residential, alarm systems, test equipment, etc.), other than an ITE application, may require further evaluation.

Warning: Anchor the equipment rack: The equipment rack must be anchored to an unmovable support to prevent it from falling over when one or more servers are extended in front of the rack on slides. You must also consider the weight of any other device installed in the rack. A crush hazard exists should the rack tilt forward which could cause serious injury.

A.2.1 If AC Power Supplies Are Installed

Mains AC power disconnect: The AC power cord(s) is considered the mains disconnect for the server and must be readily accessible when installed. If the individual server power cord(s) will not be readily accessible for disconnection then you must install an AC power disconnect for the entire rack unit. This main disconnect must be readily accessible, and it must be labeled as controlling power to the entire rack, not just to the server(s).

Grounding the rack installation: To avoid the potential for an electrical shock hazard, you must include a third wire safety ground conductor with the rack installation. If the server power cord is plugged into an AC outlet that is part of the rack, then you must



provide proper grounding for the rack itself. If the server power cord is plugged into a wall AC outlet, the safety ground conductor in the power cord provides proper grounding only for the server. You must provide additional, proper grounding for the rack and other devices installed in it. This system is intended for connection to a Common Bonding Network (CBN) as defined by NEBS GR-1089.

Overcurrent protection: The server is designed for an AC line voltage source with up to 20 amperes of overcurrent protection per cord feed. If the power system for the equipment rack is installed on a branch circuit with more than 20 amperes of protection, you must provide supplemental protection for the server. The overall current rating of a configured server is less than 6 amperes.

Warning: Do not attempt to modify or use an AC power cordset that is not the exact type required. You must use a power cordset that meets the following criteria:

- Rating: In the U.S. and Canada, cords must be UL (Underwriters Laboratories, Inc.) Listed/CSA (Canadian Standards Organization) Certified type SJT, 18-3 AWG (American Wire Gauge). Outside of the U.S. and Canada, cords must be flexible harmonized (<HAR>) or VDE (Verband Deutscher Elektrotechniker, German Institute of Electrical Engineers) certified cord with 3 x 0.75 mm conductors rated 250 VAC.
- Connector, wall outlet end: Cords must be terminated in grounding-type male plug designed for use in your region. The connector must have certification marks showing certification by an agency acceptable in your region and for U.S. must be Listed and rated 125% of overall current rating of the server.
- Connector, server end: The connectors that plug into the AC receptacle on the server must be an approved IEC (International Electrotechnical Commission) 320, sheet C13, type female connector.
- Cord length and flexibility: Cords must be less than 4.5 meters (14.8 feet) long.

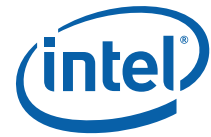
A.2.2 If DC Power Supplies Are Installed

Connection with a DC (Direct Current) source should only be performed by trained service personnel. The server with DC input is to be installed in a Restricted Access Location in accordance with articles 110-26 and 110-27 of the National Electric Code, ANSI/NFPA 70. The DC source must be electrically isolated by double or reinforced insulation from any hazardous AC source. The DC source must be capable of providing up to 300 watts of continuous power per feed pair.

Mains DC power disconnect: You are responsible for installing a properly rated DC power disconnect for the server system. This mains disconnect must be readily accessible, and it must be labeled as controlling power to the server. The UL Listed circuit breaker of a centralized DC power system may be used as a disconnect device when easily accessible and should be rated no more than 10 amps.

Grounding the server: This server is intended for installation with an isolated DC return (DC-I) and is to be installed in a Common Bonding Network (CBN) per NEBS GR-1089. To avoid the potential for an electrical shock hazard, you must reliably connect an earth grounding conductor to the server. The earth grounding conductor must be a minimum 14AWG connected to the earth ground stud(s) on the rear of the server. The safety ground conductor should be connected to the chassis stud with a Listed closed two-hole crimp terminal having 5/8-inch pitch. The nuts on the chassis earth ground studs should be installed with a 10 in-lb torque. The safety ground conductor provides proper grounding only for the server. You must provide additional, proper grounding for the rack and other devices installed in it.

Overcurrent protection: Overcurrent protection UL Listed circuit breakers must be provided as part of each host equipment rack and must be incorporated in the field wiring between the DC source and the server. The branch circuit protection shall be



rated minimum 75Vdc, 10 A maximum per feed pair. If the DC power system for the equipment rack is installed with more than 10 amperes of protection, you must provide supplemental protection for the server. The overall current rating of a maximum configured server is 8 amperes.

A.2.3 Temperature and Ventilation

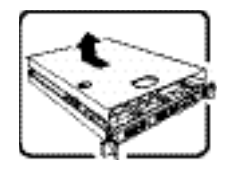
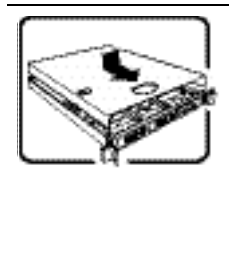
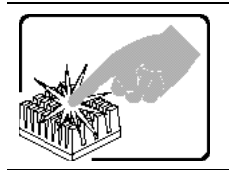
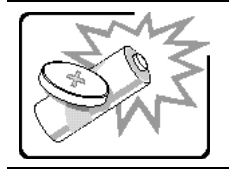
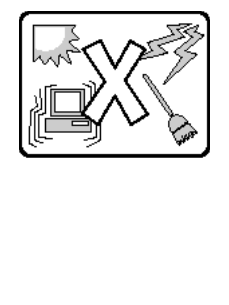
Caution: Temperature: The temperature, in which the server operates when installed in an equipment rack, must not go below 5°C (41°F) or rise above 35°C (95°F). Extreme fluctuations in temperature can cause a variety of problems in your server.

Caution: Ventilation: The equipment rack must provide sufficient airflow to the front of the server to maintain proper cooling. The rack must also include ventilation sufficient to exhaust a maximum of 1023 BTUs (British Thermal Units) per hour for the server. The rack selected and the ventilation provided must be suitable to the environment in which the server will be used.

A.3 Safety Cautions

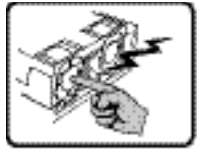
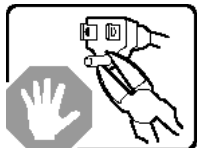
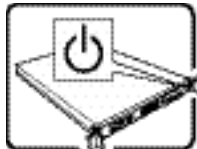

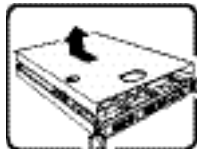
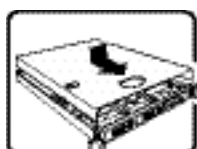
Read all caution and safety statements in this document before performing any of the instructions. See also the most current Intel Server Boards and Server Chassis Safety Information which is provided at <http://support.intel.com/support/motherboards/server/sb/CS-010770.htm>

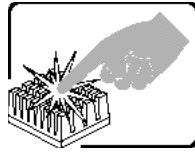
	<p>The power supply in this product contains no user-serviceable parts. There may be more than one supply in this product. Refer servicing only to qualified personnel.</p>
	<p>Do not attempt to modify or use the supplied AC power cord if it is not the exact type required. A product with more than one power supply will have a separate AC power cord for each supply.</p>
	<p>The power button on the system does not turn off system AC power. To remove AC power from the system, you must unplug each AC power cord from the wall outlet or power supply. The power cord(s) is considered the disconnect device to the main (AC) power. The socket outlet that the system plugs into must be installed near the equipment and must be easily accessible.</p>
	<p>SAFETY STEPS: Whenever you remove the chassis covers to access the inside of the system, follow these steps:</p> <ol style="list-style-type: none"> 1. Turn off all peripheral devices connected to the system. 2. Turn off the system by pressing the power button. 3. Unplug all AC power cords from the system or from wall outlets. 4. Label and disconnect all cables connected to I/O connectors or ports on the back of the system. 5. Provide electrostatic discharge (ESD) protection by wearing an antistatic wrist strap attached to chassis ground of the system—any unpainted metal surface—when handling components. 6.

	<p>After you have completed the six SAFETY STEPS above, you can remove the system covers. To do this:</p> <ol style="list-style-type: none"> 1. Unlock and remove the padlock from the back of the system if a padlock has been installed. 2. Remove and save all screws from the covers. 3. Remove the covers. 4. Do not operate the system with the chassis covers removed.
	<p>For proper cooling and airflow, always reinstall the chassis covers before turning on the system. Operating the system without the covers in place can damage system parts. To install the covers:</p> <ol style="list-style-type: none"> 1. Check first to make sure you have not left loose tools or parts inside the system. 2. Check that cables, add-in boards, and other components are properly installed. 3. Attach the covers to the chassis with the screws removed earlier, and tighten them firmly. 4. Insert and lock the padlock to the system to prevent unauthorized access inside the system. 5. Connect all external cables and the AC power cord(s) to the system.
	<p>A microprocessor and heat sink may be hot if the system has been running. Also, there may be sharp pins and edges on some board and chassis parts. Contact should be made with care. Consider wearing protective gloves.</p>
	<p>Danger of explosion if the battery is incorrectly replaced. Replace only with the same or equivalent type recommended by the equipment manufacturer. Dispose of used batteries according to manufacturer's instructions.</p>
	<p>The system is designed to operate in a typical office environment. Choose a site that is:</p> <ul style="list-style-type: none"> • Clean and free of airborne particles (other than normal room dust). • Well ventilated and away from sources of heat including direct sunlight. • Away from sources of vibration or physical shock. • Isolated from strong electromagnetic fields produced by electrical devices. • In regions that are susceptible to electrical storms, we recommend you plug your system into a surge suppresser and disconnect telecommunication lines to your modem during an electrical storm. • Provided with a properly grounded wall outlet. • Provided with sufficient space to access the power supply cord(s), because they serve as the product's main power disconnect.

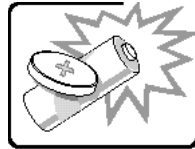
Wichtige Sicherheitshinweise

Lesen Sie zunächst sämtliche Warn- und Sicherheitshinweise in diesem Dokument, bevor Sie eine der Anweisungen ausführen. Beachten Sie hierzu auch die Sicherheitshinweise zu Intel-Serverplatinen und -Servergehäusen unter <http://support.intel.com/support/motherboards/server/sb/CS-010770.htm>

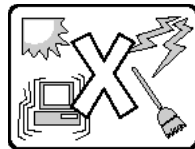
	<p>Benutzer können am Netzgerät dieses Produkts keine Reparaturen vornehmen. Das Produkt enthält möglicherweise mehrere Netzgeräte. Wartungsarbeiten müssen von qualifizierten Technikern ausgeführt werden.</p>
	<p>Versuchen Sie nicht, das mitgelieferte Netzkabel zu ändern oder zu verwenden, wenn es sich nicht genau um den erforderlichen Typ handelt. Ein Produkt mit mehreren Netzgeräten hat für jedes Netzgerät ein eigenes Netzkabel.</p>
	<p>Der Wechselstrom des Systems wird durch den Ein-/Aus-Schalter für Gleichstrom nicht ausgeschaltet. Ziehen Sie jedes Wechselstrom-Netzkabel aus der Steckdose bzw. dem Netzgerät, um den Stromanschluß des Systems zu unterbrechen.</p>
	<p>SICHERHEITSMASSNAHMEN: Immer wenn Sie die Gehäuseabdeckung abnehmen um an das Systeminnere zu gelangen, sollten Sie folgende Schritte beachten:</p> <ol style="list-style-type: none"> 1. Schalten Sie alle an Ihr System angeschlossenen Peripheriegeräte aus. 2. Schalten Sie das System mit dem Hauptschalter aus. 3. Ziehen Sie den Stromanschlußstecker Ihres Systems aus der Steckdose. 4. Auf der Rückseite des Systems beschriftet und ziehen Sie alle Anschlußkabel von den I/O Anschlüssen oder Ports ab. 5. Tragen Sie ein geerdetes Antistatik Gelenkband, um elektrostatische Ladungen (ESD) über blanke Metallstellen bei der Handhabung der Komponenten zu vermeiden. 6. Schalten Sie das System niemals ohne ordnungsgemäß montiertes Gehäuse ein.
	<p>Nachdem Sie die oben erwähnten ersten sechs SICHERHEITSSCHRITTE durchgeführt haben, können Sie die Abdeckung abnehmen, indem Sie:</p> <ol style="list-style-type: none"> 1. Öffnen und entfernen Sie die Verschlusseinrichtung (Padlock) auf der Rückseite des Systems, falls eine Verschlusseinrichtung installiert ist. 2. Entfernen Sie alle Schrauben der Gehäuseabdeckung. 3. Nehmen Sie die Abdeckung ab.
	<p>Zur ordnungsgemäßen Kühlung und Lüftung muß die Gehäuseabdeckung immer wieder vor dem Einschalten installiert werden. Ein Betrieb des Systems ohne angebrachte Abdeckung kann Ihrem System oder Teile darin beschädigen. Um die Abdeckung wieder anzubringen:</p> <ol style="list-style-type: none"> 1. Vergewissern Sie sich, daß Sie keine Werkzeuge oder Teile im Innern des Systems zurückgelassen haben. 2. Überprüfen Sie alle Kabel, Zusatzkarten und andere Komponenten auf ordnungsgemäßen Sitz und Installation. 3. Bringen Sie die Abdeckungen wieder am Gehäuse an, indem Sie die zuvor gelösten Schrauben wieder anbringen. Ziehen Sie diese gut an. 4. Bringen Sie die Verschlusseinrichtung (Padlock) wieder an und schließen Sie diese, um ein unerlaubtes Öffnen des Systems zu verhindern. 5. Schließen Sie alle externen Kabel und den AC Stromanschlußstecker Ihres Systems wieder an.



Der Mikroprozessor und der Kühler sind möglicherweise erhitzt, wenn das System in Betrieb ist. Außerdem können einige Platinen und Gehäuseteile scharfe Spitzen und Kanten aufweisen. Arbeiten an Platinen und Gehäuse sollten vorsichtig ausgeführt werden. Sie sollten Schutzhandschuhe tragen.



Bei falschem Einsetzen einer neuen Batterie besteht Explosionsgefahr. Die Batterie darf nur durch denselben oder einen entsprechenden, vom Hersteller empfohlenen Batterietyp ersetzt werden. Entsorgen Sie verbrauchte Batterien den Anweisungen des Herstellers entsprechend.



Das System wurde für den Betrieb in einer normalen Büroumgebung entwickelt. Der Standort sollte:

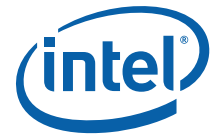
- sauber und staubfrei sein (Hausstaub ausgenommen);
- gut gelüftet und keinen Heizquellen ausgesetzt sein (einschließlich direkter Sonneneinstrahlung);
- keinen Erschütterungen ausgesetzt sein;
- keine starken, von elektrischen Geräten erzeugten elektromagnetischen Felder aufweisen;
- in Regionen, in denen elektrische Stürme auftreten, mit einem Überspannungsschutzgerät verbunden sein; während eines elektrischen Sturms sollte keine Verbindung der Telekommunikationsleitungen mit dem Modem bestehen;
- mit einer geerdeten Wechselstromsteckdose ausgerüstet sein;
- über ausreichend Platz verfügen, um Zugang zu den Netzkabeln zu gewährleisten, da der Stromanschluß des Produkts hauptsächlich über die Kabel unterbrochen wird.

重要安全指导

在执行任何指令之前，请阅读本文档中的所有注意事项及安全声明。和/或<http://support.intel.com/support/motherboards/server/sb/cs-010770.htm> 上的 *Intel Server Boards and Server Chassis Safety Information* (《Intel 服务器主板与服务器机箱安全信息》)。

Consignes de sécurité

Lisez attention toutes les consignes de sécurité et les mises en garde indiquées dans ce document avant de suivre toute instruction. Consultez Intel Server Boards and Server Chassis Safety Information sur le site <http://support.intel.com/support/motherboards/server/sb/CS-010770.htm>



	<p>Le bloc d'alimentation de ce produit ne contient aucune pièce pouvant être réparée par l'utilisateur. Ce produit peut contenir plus d'un bloc d'alimentation. Veuillez contacter un technicien qualifié en cas de problème.</p>
	<p>Ne pas essayer d'utiliser ni modifier le câble d'alimentation CA fourni, s'il ne correspond pas exactement au type requis. Le nombre de câbles d'alimentation CA fournis correspond au nombre de blocs d'alimentation du produit.</p>
	<p>Notez que le commutateur CC de mise sous tension /hors tension du panneau avant n'éteint pas l'alimentation CA du système. Pour mettre le système hors tension, vous devez débrancher chaque câble d'alimentation de sa prise.</p>
	<p>CONSIGNES DE SÉCURITÉ -Lorsque vous ouvrez le boîtier pour accéder à l'intérieur du système, suivez les consignes suivantes:</p> <ol style="list-style-type: none"> 1. Mettez hors tension tous les périphériques connectés au système. 2. Mettez le système hors tension en mettant l'interrupteur général en position OFF (bouton-poussoir). 3. Débranchez tous les cordons d'alimentation c.a. du système et des prises murales. 4. Identifiez et débranchez tous les câbles reliés aux connecteurs d'E-S ou aux accès derrière le système. 5. Pour prévenir les décharges électrostatiques lorsque vous touchez aux composants, portez une bande antistatique pour poignet et reliez-la à la masse du système (toute surface métallique non peinte du boîtier). 6. Ne faites pas fonctionner le système tandis que le boîtier est ouvert.
	<p>Une fois TOUTES les étapes précédentes accomplies, vous pouvez retirer les panneaux du système. Procédez comme suit:</p> <ol style="list-style-type: none"> 1. Si un cadenas a été installé sur à l'arrière du système, déverrouillez-le et retirez-le. 2. Retirez toutes les vis des panneaux et mettez-les dans un endroit sûr. 3. Retirez les panneaux.
	<p>Afin de permettre le refroidissement et l'aération du système, réinstallez toujours les panneaux du boîtier avant de mettre le système sous tension. Le fonctionnement du système en l'absence des panneaux risque d'endommager ses pièces. Pour installer les panneaux, procédez comme suit:</p> <ol style="list-style-type: none"> 1. Assurez-vous de ne pas avoir oublié d'outils ou de pièces démontées dans le système. 2. Assurez-vous que les câbles, les cartes d'extension et les autres composants sont bien installés. 3. Revissez solidement les panneaux du boîtier avec les vis retirées plus tôt. 4. Remettez le cadenas en place et verrouillez-le afin de prévenir tout accès non autorisé à l'intérieur du système. 5. Rebranchez tous les cordons d'alimentation c. a. et câbles externes au système.

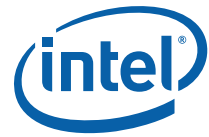
	<p>Le microprocesseur et le dissipateur de chaleur peuvent être chauds si le système a été sous tension. Faites également attention aux broches aiguës des cartes et aux bords tranchants du capot. Nous vous recommandons l'usage de gants de protection.</p>
	<p>Danger d'explosion si la batterie n'est pas remontée correctement. Remplacer uniquement avec une batterie du même type ou d'un type équivalent recommandé par le fabricant. Disposez des piles usées selon les instructions du fabricant.</p>
	<p>Le système a été conçu pour fonctionner dans un cadre de travail normal. L'emplacement choisi doit être:</p> <ul style="list-style-type: none"> • Propre et dépourvu de poussière en suspension (sauf la poussière normale). • Bien aéré et loin des sources de chaleur, y compris du soleil direct. • A l'abri des chocs et des sources de vibrations. • Isolé de forts champs électromagnétiques géénérés par des appareils électriques. • Dans les régions sujettes aux orages magnétiques il est recomandé de brancher votre système à un supresseur de surtension, et de débrancher toutes les lignes de télécommunications de votre modem durant un orage. • Muni d'une prise murale correctement mise à la terre. • Suffisamment spacieux pour vous permettre d'accéder aux câbles d'alimentation (ceux-ci étant le seul moyen de mettre le système hors tension).

Instrucciones de seguridad importantes

Lea todas las declaraciones de seguridad y precaución de este documento antes de realizar cualquiera de las instrucciones. Vea Intel Server Boards and Server Chassis Safety Information en

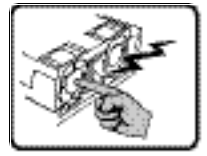
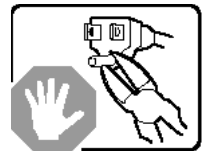
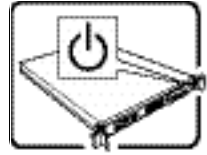

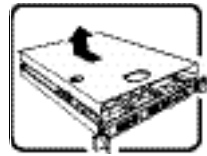
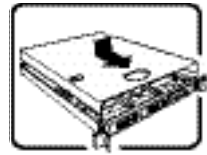
<http://support.intel.com/support/motherboards/server/sb/CS-010770.htm>

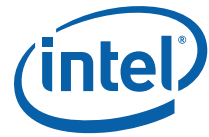
	<p>El usuario debe abstenerse de manipular los componentes de la fuente de alimentación de este producto, cuya reparación debe dejarse exclusivamente en manos de personal técnico especializado. Puede que este producto disponga de más de una fuente de alimentación.</p>
	<p>No intente modificar ni usar el cable de alimentación de corriente alterna, si no corresponde exactamente con el tipo requerido. El número de cables suministrados se corresponden con el número de fuentes de alimentación de corriente alterna que tenga el producto.</p>
	<p>Nótese que el interruptor activado/desactivado en el panel frontal no desconecta la corriente alterna del sistema. Para desconectarla, deberá desenchar todos los cables de corriente alterna de la pared o desconectar la fuente de alimentación.</p>



	<p>INSTRUCCIONES DE SEGURIDAD: Cuando extraiga la tapa del chasis para acceder al interior del sistema, siga las siguientes instrucciones:</p> <ol style="list-style-type: none"> 1. Apague todos los dispositivos periféricos conectados al sistema. 2. Apague el sistema presionando el interruptor encendido/apagado. 3. Desconecte todos los cables de alimentación CA del sistema o de las tomas de corriente alterna. 4. Identifique y desconecte todos los cables enchufados a los conectores E/S o a los puertos situados en la parte posterior del sistema. 5. Cuando manipule los componentes, es importante protegerse contra la descarga electrostática (ESD). Puede hacerlo si utiliza una muñequera antiestática sujeta a la toma de tierra del chasis - o a cualquier tipo de superficie de metal sin pintar. 6. No ponga en marcha el sistema si se han extraído las tapas del chasis.
	<p>Después de completar las seis instrucciones de SEGURIDAD mencionadas, ya puede extraer las tapas del sistema. Para ello:</p> <ol style="list-style-type: none"> 1. Desbloquee y extraiga el bloqueo de seguridad de la parte posterior del sistema, si se ha instalado uno. 2. Extraiga y guarde todos los tornillos de las tapas. 3. Extraiga las tapas.
	<p>Para obtener un enfriamiento y un flujo de aire adecuados, reinstale siempre las tapas del chasis antes de poner en marcha el sistema. Si pone en funcionamiento el sistema sin las tapas bien colocadas puede dañar los componentes del sistema. Para instalar las tapas:</p> <ol style="list-style-type: none"> 1. Asegúrese primero de no haber dejado herramientas o componentes sueltos dentro del sistema. 2. Compruebe que los cables, las placas adicionales y otros componentes se hayan instalado correctamente. 3. Incorpore las tapas al chasis mediante los tornillos extraídos anteriormente, tensándolos firmemente. 4. Inserte el bloqueo de seguridad en el sistema y bloquéelo para impedir que pueda accederse al mismo sin autorización. 5. Conecte todos los cables externos y los cables de alimentación CA al sistema.
	<p>Si el sistema ha estado en funcionamiento, el microprocesador y el disipador de calor pueden estar aún calientes. También conviene tener en cuenta que en el chasis o en el tablero puede haber piezas cortantes o punzantes. Por ello, se recomienda precaución y el uso de guantes protectores.</p>
	<p>Existe peligro de explosión si la pila no se cambia de forma adecuada. Utilice solamente pilas iguales o del mismo tipo que las recomendadas por el fabricante del equipo. Para deshacerse de las pilas usadas, siga igualmente las instrucciones del fabricante.</p>
	<p>El sistema está diseñado para funcionar en un entorno de trabajo normal. Escoja un lugar:</p> <ul style="list-style-type: none"> • Limpio y libre de partículas en suspensión (salvo el polvo normal). • Bien ventilado y alejado de fuentes de calor, incluida la luz solar directa. • Alejado de fuentes de vibración. • Aislado de campos electromagnéticos fuertes producidos por dispositivos eléctricos. • En regiones con frecuentes tormentas eléctricas, se recomienda conectar su sistema a un eliminador de sobrevoltage y desconectar el módem de las líneas de telecomunicación durante las tormentas. • Provisto de una toma de tierra correctamente instalada. • Provisto de espacio suficiente como para acceder a los cables de alimentación, ya que éstos hacen de medio principal de desconexión del sistema.

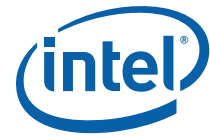
Informazioni di Sicurezza importanti

	<p>Rivolgersi ad un tecnico specializzato per la riparazione dei componenti dell'alimentazione di questo prodotto. È possibile che il prodotto disponga di più fonti di alimentazione.</p>
	<p>Non modificare o utilizzare il cavo di alimentazione in c.a. fornito dal produttore, se non corrisponde esattamente al tipo richiesto. Ad ogni fonte di alimentazione corrisponde un cavo di alimentazione in c.a. separato.</p>
	<p>L'interruttore attivato/disattivato nel pannello anteriore non interrompe l'alimentazione in c.a. del sistema. Per interromperla, è necessario scollegare tutti i cavi di alimentazione in c.a. dalle prese a muro o dall'alimentazione di corrente.</p>
	<p>PASSI DI SICUREZZA: Qualora si rimuovano le coperture del telaio per accedere all'interno del sistema, seguire i seguenti passi:</p> <ol style="list-style-type: none"> 1. Spegner tutti i dispositivi periferici collegati al sistema. 2. Spegner il sistema, usando il pulsante spento/acceso dell'interruttore del sistema. 3. Togliere tutte le spine dei cavi del sistema dalle prese elettriche. 4. Identificare e sconnettere tutti i cavi attaccati ai collegamenti I/O od alle prese installate sul retro del sistema. 5. Qualora si tocchino i componenti, proteggersi dallo scarico elettrostatico (SES), portando un cinghia anti-statica da polso che è attaccata alla presa a terra del telaio del sistema - qualsiasi superficie non dipinta - . 6. Non far operare il sistema quando il telaio è senza le coperture.
	<p>Dopo aver seguito i sei passi di SICUREZZA sopracitati, togliere le coperture del telaio del sistema come segue:</p> <ol style="list-style-type: none"> 1. Aprire e rimuovere il lucchetto dal retro del sistema qualora ve ne fosse uno installato. 2. Togliere e mettere in un posto sicuro tutte le viti delle coperture. 3. Togliere le coperture.
	<p>Per il giusto flusso dell'aria e raffreddamento del sistema, rimettere sempre le coperture del telaio prima di riaccendere il sistema. Operare il sistema senza le coperture al loro proprio posto potrebbe danneggiare i componenti del sistema. Per rimettere le coperture del telaio:</p> <ol style="list-style-type: none"> 1. Controllare prima che non si siano lasciati degli attrezzi o dei componenti dentro il sistema. 2. Controllare che i cavi, dei supporti aggiuntivi ed altri componenti siano stati installati appropriatamente. 3. Attaccare le coperture al telaio con le viti tolte in precedenza e avvitarle strettamente. 4. Inserire e chiudere a chiave il lucchetto sul retro del sistema per impedire l'accesso non autorizzato al sistema. 5. Ricollegare tutti i cavi esterni e le prolunghe AC del sistema.



	<p>Se il sistema è stato a lungo in funzione, il microprocessore e il dissipatore di calore potrebbero essere surriscaldati. Fare attenzione alla presenza di piedini appuntiti e parti taglienti sulle schede e sul telaio. È consigliabile l'uso di guanti di protezione.</p>
	<p>Esiste il pericolo di un'esplosione se la pila non viene sostituita in modo corretto. Utilizzare solo pile uguali o di tipo equivalente a quelle consigliate dal produttore. Per disfarsi delle pile usate, seguire le istruzioni del produttore.</p>
	<p>Il sistema è progettato per funzionare in un ambiente di lavoro tipo. Scegliere una postazione che sia:</p> <ul style="list-style-type: none"> • Pulita e libera da particelle in sospensione (a parte la normale polvere presente nell'ambiente). • Ben ventilata e lontana da fonti di calore, compresa la luce solare diretta. • Al riparo da urti e lontana da fonti di vibrazione. • Isolata dai forti campi magnetici prodotti da dispositivi elettrici. • In aree soggette a temporali, è consigliabile collegare il sistema ad un limitatore di corrente. In caso di temporali, scollegare le linee di comunicazione dal modem. • Dotata di una presa a muro correttamente installata. • Dotata di spazio sufficiente ad accedere ai cavi di alimentazione, i quali rappresentano il mezzo principale di scollegamento del sistema.





Appendix B: Regulatory and Certification Information

B.1 Product Regulatory Compliance

B.1.1 Product Safety Compliance

The Carrier Grade Server TIGW1U complies with the following safety requirements:

- UL60950-1 /CSA 60950-1 (USA / Canada)
- EN60950-1 (Europe)
- IEC60950-1 (International), CB Certificate & Report including all international deviations
- GS Certificate (Germany)
- GOST R Approval (Russia)
- CE - Low Voltage Directive 73/23/EEE (Europe)
- CCC Certification (China)
- BSMI CNS 13436 (Taiwan)

B.1.2 Product EMC Compliance - Class A Compliance

The Carrier Grade Server TIGW1U has been tested and verified to comply with the following electromagnetic compatibility (EMC) regulations:

- FCC /ICES-003 - Emissions (USA/Canada)
- CISPR 22 - Emissions (International)
- EN55022 - Emissions (Europe)
- EN55024 - Immunity (Europe)
- EN61000-3-2 - Harmonics (Europe)
- EN61000-3-3 - Voltage Flicker (Europe)
- CE- EMC Directive 89/336/EEC (Europe)
- VCCI Emissions (Japan)
- AS/NZS: CISPR 22 Emissions (Australia/New Zealand)
- BSMI CNS13438 Emissions (Taiwan)
- GOST R Approval Emissions and Immunity (Russia)
- RRL Approval (Korea)
- CCC Certification (China)

B.1.3 Certifications / Registrations / Declarations

- UL Listing (US/Canada)
- CE Declaration of Conformity (Europe)



- FCC/ICES-003 Class A Verification Report (USA/Canada)
- VCCI Certification (Japan)
- C-Tick Declaration of Conformity (Australia)
- BSMI Certification (Taiwan)
- GOST R Certification/License (Russia)
- RRL Certification (Korea)
- CNCA Certification (China)
- Ecology Declaration (International)

Note: The Carrier Grade Server TIGW1U is not suitable for use with a visual display workplace device according to the German Ordinance for Work with Visual Display Units because it has a glossy front.

B.2 Electromagnetic Compatibility Notices

B.2.1 FCC (USA)

This device complies with Part 15 of the FCC Rules. Operation is subject to the following two conditions: (1) this device may not cause harmful interference, and (2) this device must accept any interference received, including interference that may cause undesired operation.

For questions related to the EMC performance of this product, contact:

Intel Corporation
5200 N.E. Elam Young Parkway
Hillsboro, OR 97124
1-800-628-8686

This equipment has been tested and found to comply with the limits for a Class A digital device, pursuant to Part 15 of the FCC Rules. These limits are designed to provide reasonable protection against harmful interference in a residential installation. This equipment generates, uses, and can radiate radio frequency energy and, if not installed and used in accordance with the instructions, may cause harmful interference to radio communications. However, there is no guarantee that interference will not occur in a particular installation. If this equipment does cause harmful interference to radio or television reception, which can be determined by turning the equipment off and on, the user is encouraged to try to correct the interference by one or more of the following measures:

- Reorient or relocate the receiving antenna.
- Increase the separation between the equipment and the receiver.
- Connect the equipment to an outlet on a circuit other than the one to which the receiver is connected.
- Consult the dealer or an experienced radio/TV technician for help.

Any changes or modifications not expressly approved by the grantee of this device could void the user's authority to operate the equipment. The customer is responsible for ensuring compliance of the modified product.

Only peripherals (computer input/output devices, terminals, printers, etc.) that comply with FCC Class A or B limits may be attached to this computer product. Operation with noncompliant peripherals is likely to result in interference to radio and TV reception.



All cables used to connect to peripherals must be shielded and grounded. Operation with cables connected to peripherals that are not shielded and grounded may result in interference to radio and TV reception.

B.2.2 Industry Canada (ICES-003)

Cet appareil numérique respecte les limites bruits radioélectriques applicables aux appareils numériques de Classe A prescrites dans la norme sur le matériel brouilleur: "Appareils Numériques", NMB-003 édictée par le Ministre Canadien des Communications.

English translation of the notice above:

This digital apparatus does not exceed the Class A limits for radio noise emissions from digital apparatus set out in the interference-causing equipment standard entitled "Digital Apparatus", ICES-003 of the Canadian Department of Communications.

B.2.3 Europe (CE Declaration of Conformity)

This product has been tested in accordance to, and complies with, the Low Voltage Directive (73/23/EEC) and EMC Directive (89/336/EEC). The product has been marked with the CE Mark to illustrate its compliance.

B.2.4 VCCI (Japan)

この装置は、情報処理装置等電波障害自主規制協議会（VCCI）の基準に基づくクラスA情報技術装置です。この装置を家庭環境で使用すると電波妨害を引き起こすことがあります。この場合には使用者が適切な対策を講ずるよう要求されることがあります。

English translation of the notice above:

This is a Class A product based on the standard of the Voluntary Control Council for Interference (VCCI) from Information Technology Equipment. If this is used near a radio or television receiver in a domestic environment, it may cause radio interference. Install and use the equipment according to the instruction manual.

B.2.5 BSMI (Taiwan)

警告使用者：
這是甲類的資訊產品，在居住的環境中使用時，可能會造成射頻干擾，在這種情況下，使用者會被要求採取某些適當的對策



The BSMI Certification Marking and EMC warning is located on the outside rear area of the product.

B.2.6 Regulated Specified Components

To maintain the UL listing and compliance to other regulatory certifications and/or declarations, the following conditions must be adhered to and the following regulated components must be used. Interchanging or using other components will void the UL listing and other product certifications and approvals.

1. Add-in boards must have a printed wiring board flammability rating of minimum UL94V-1. Add-in boards containing external power connectors and/or lithium batteries must be UL recognized or UL listed. Any add-in board containing modem telecommunication circuitry must be UL listed. In addition, the modem must have the appropriate telecommunications, safety, and EMC approvals for the region in which it is sold.
2. Peripheral Storage Devices must be a UL recognized or UL listed accessory and TUV or VDE licensed. Maximum power rating of any one device is 19 watts. Total server configuration is not to exceed the maximum loading conditions of the power supply.



Appendix C: Getting Help

C.1 World Wide Web

<http://support.intel.com/support/telecom/computeboards/tigw1u/>

Use the “Intel® Server Issue Report Form” found on this web site and submit it via the Internet or email.

C.2 Telephone

All calls are billed at US\$25.00 per incident, and levied in local currency at the applicable credit card exchange rate plus applicable taxes. (Intel reserves the right to change the pricing for telephone support at any time without notice).

Before calling, fill out an “Intel® Server Issue Report Form”, which you can find on the support web site, <http://support.intel.com/support/telecom/computeboards/tigw1u/>. However, for the fastest service, please submit your form via the Internet or email.

In U.S. and Canada	
1-800-404-2284	
In Europe	
UK 0870 6072439	Finland 9 693 79297
France 01 41 918529	Denmark 38 487077
Germany 069 9509 6099	Norway 23 1620 50
Italy 02 696 33276	Sweden 08 445 1251
Spain 91 377 8166	Holland 020 487 4562
In Asia-Pacific region	
Australia 1800 649931	Indonesia 001-803 65 7249
Hong Kong 852 2 844 4456	Malaysia 1-800 80 1390
Korea 822 767 2595	New Zealand 0800 444 365
PRC 800 820 1100	Pakistan 632 6368415 (IDD via Philippines)
Singapore 65 213-1311	Philippines 1-800 1 651 0117
Taiwan 2 2545-1640	Thailand 1-800 6310003
India 0006517-830 3634	Vietnam 632 6368416 (IDD via Philippines)



In Japan	
0120-868686 (Domestic)	81-298-47-0800 (outside country)
In Latin America	
Brazil 0021-0811-408-5540	Ecuador 999-119, 800-628-8686 (via AT&T)
Mexico 001-800-628-8686	Guatemala 99-99-190, 800-628-8686 (via AT&T)
Colombia 980-9-122-118	Venezuela 800-11-120, 800-628-8686 (via AT&T)
Costa Rica 0-800-011-0395	Argentina 001-800-222-1001, 800-628-8686 (via AT&T)
Panama 001-800-628-8686	Paraguay 008-11, 800-628-8686 (via AT&T)
Chile 800-532-992	Peru 0-800-50000, 800-628-8686 (via AT&T)
Miami 1-800-621-8423	Uruguay 000-410, 800-628-8686 (via AT&T)

For an up-to-date support contact list, see <http://www.intel.com/support/9089.htm/>